

SERPAC WM023-R (exploded isometric)

Electronic Enclosures

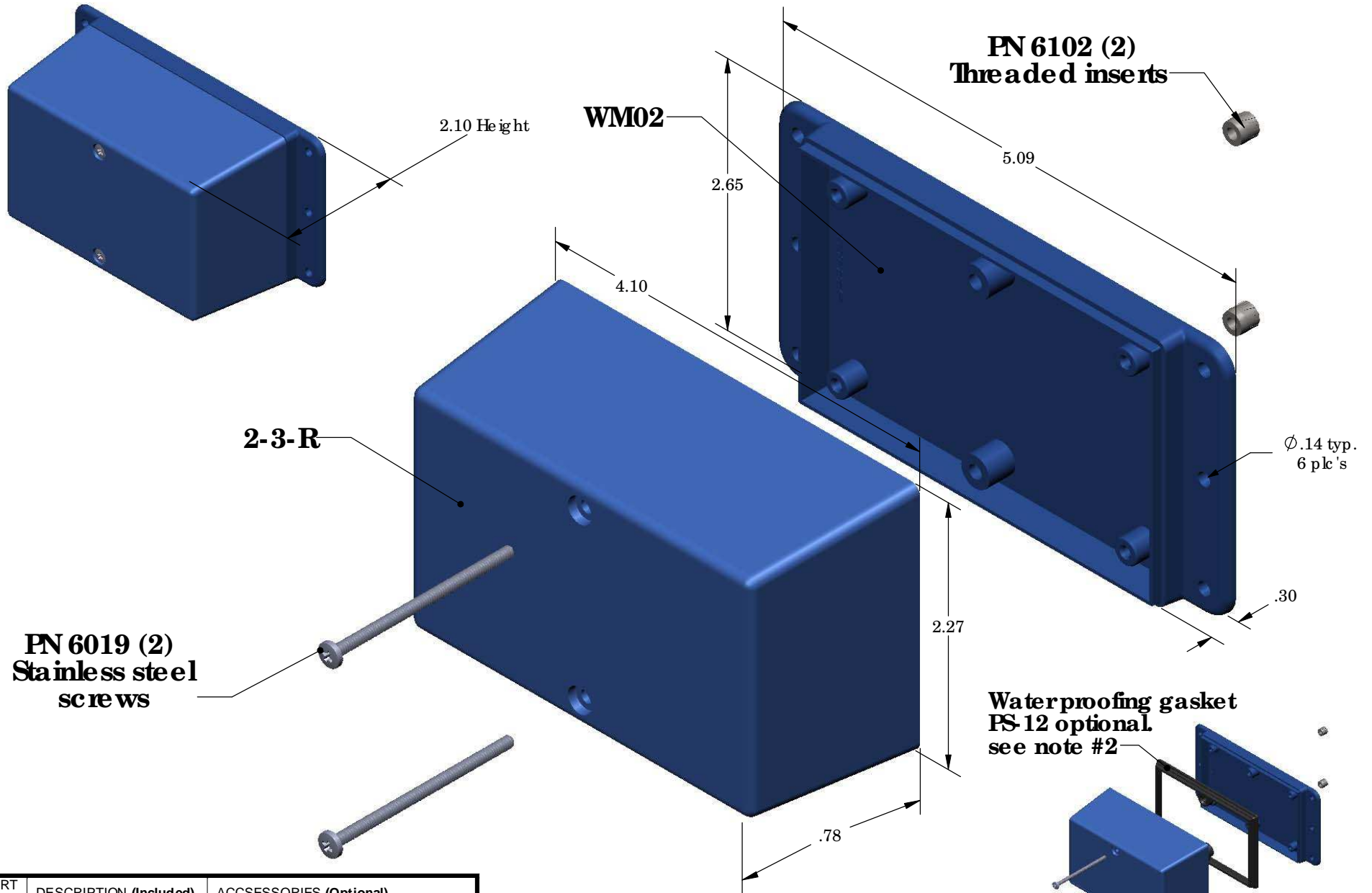

PART NO.	DESCRIPTION (Included)	ACCESSORIES (Optional)	
2-3-R	TOP	PART NO.	DESCRIPTION
WM02	BOTTOM	PS-12	Perimeter Seal
6019	4-40 SCREW (2)		
6102	THREADED INSERTS (2)		

Notes:

- 1) Enclosure meets or exceeds IP40 and NEMA 1
- 2) When used with PS-12 the enclosure meets or exceeds IP 67 and NEMA 4X, 12 and 13 MIL-STD-810G 506.5
- 3) Circuit Board drawings can be downloaded at:
http://www.serpac.com/Products/Accessories/CircuitBoard/drawings/CB_WM023.pdf
- 4) All components are RoHS Compliant.

**Waterproofing gasket
PS-12 optional
see note #2**

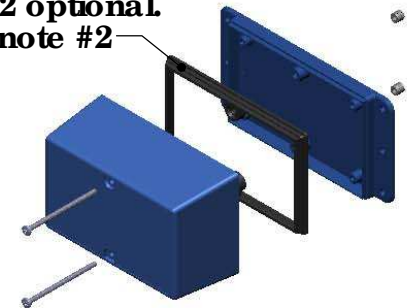

ALL DIMENSIONS ARE ±.010" 5/28/09 (1 of 2)
619 Commercial Ave. Covina, CA 91723
Ph. (626) 331-0517 Ex. (626) 331-8584 serpac.com

SERPAC WM023-R (user print)

Electronic Enclosures

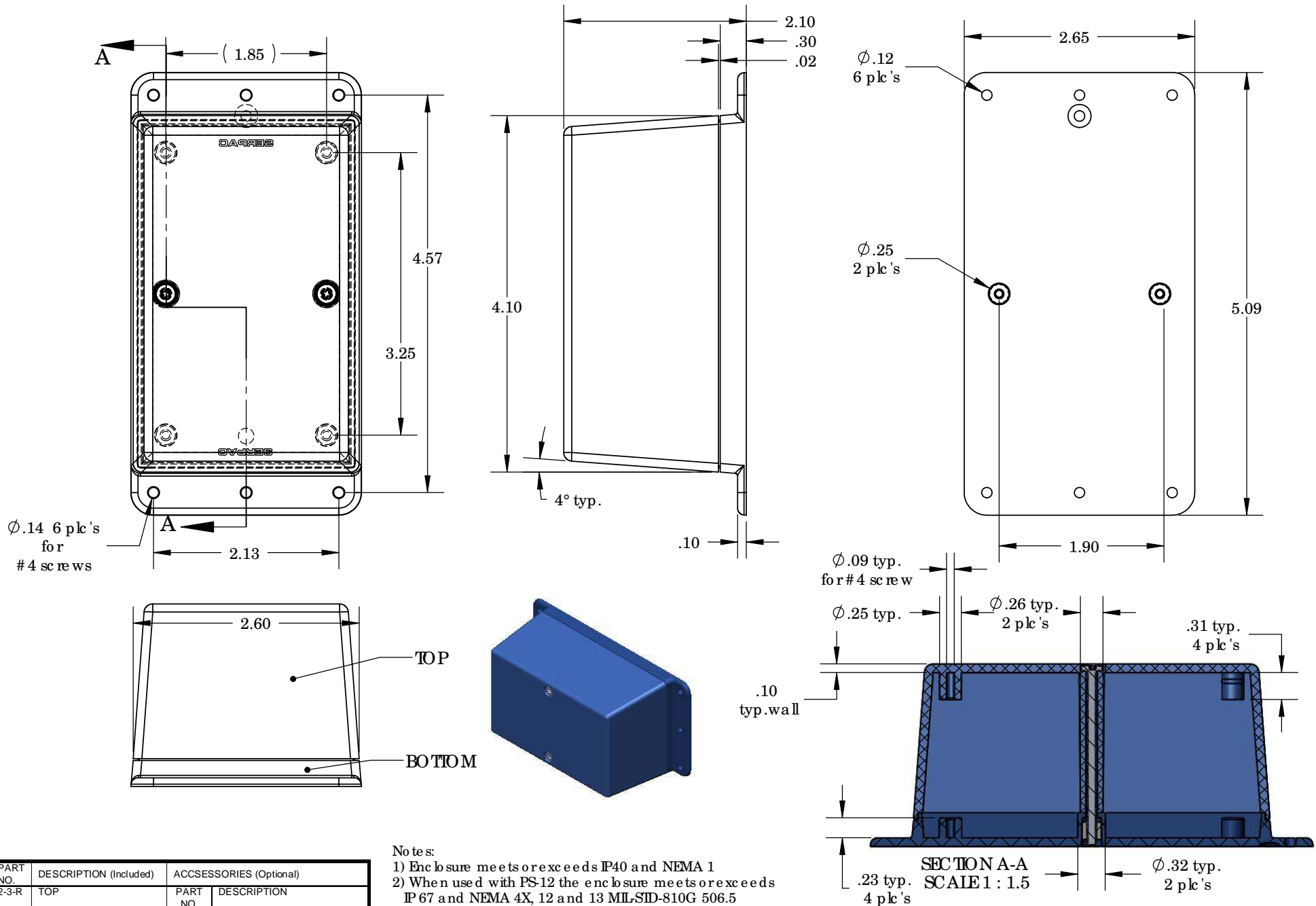

PART NO.	DESCRIPTION (Included)	ACCESSORIES (Optional)	
2-3-R	TOP	PART NO.	DESCRIPTION
WM02	BOTTOM	PS-12	Perimeter Seal
6019	4-40 SCREW (2)		
6102	THREADED INSERTS (2)		

Notes:
 1) Enclosure meets or exceeds IP40 and NEMA 1
 2) When used with PS-12 the enclosure meets or exceeds IP 67 and NEMA 4X, 12 and 13 MIL-SID-810G 506.5
 3) Circuit Board drawings can be downloaded at:
http://www.serpac.com/Products/Accessories/CircuitBoard/drawings/CB_WM023.pdf
 4) All components are RoHS Compliant.

SECTION A-A
 SCALE 1 : 1.5
 ALL DIMENSIONS ARE $\pm .010"$ 5/28/09 (2 of 2)
 619 Commercial Ave. Covina, CA 91723
 Ph. (626) 331-0517 Ex. (626) 331-8584 www.serpac.com