

# SERPAC WM013-R (exploded isometric)

Electronic Enclosures

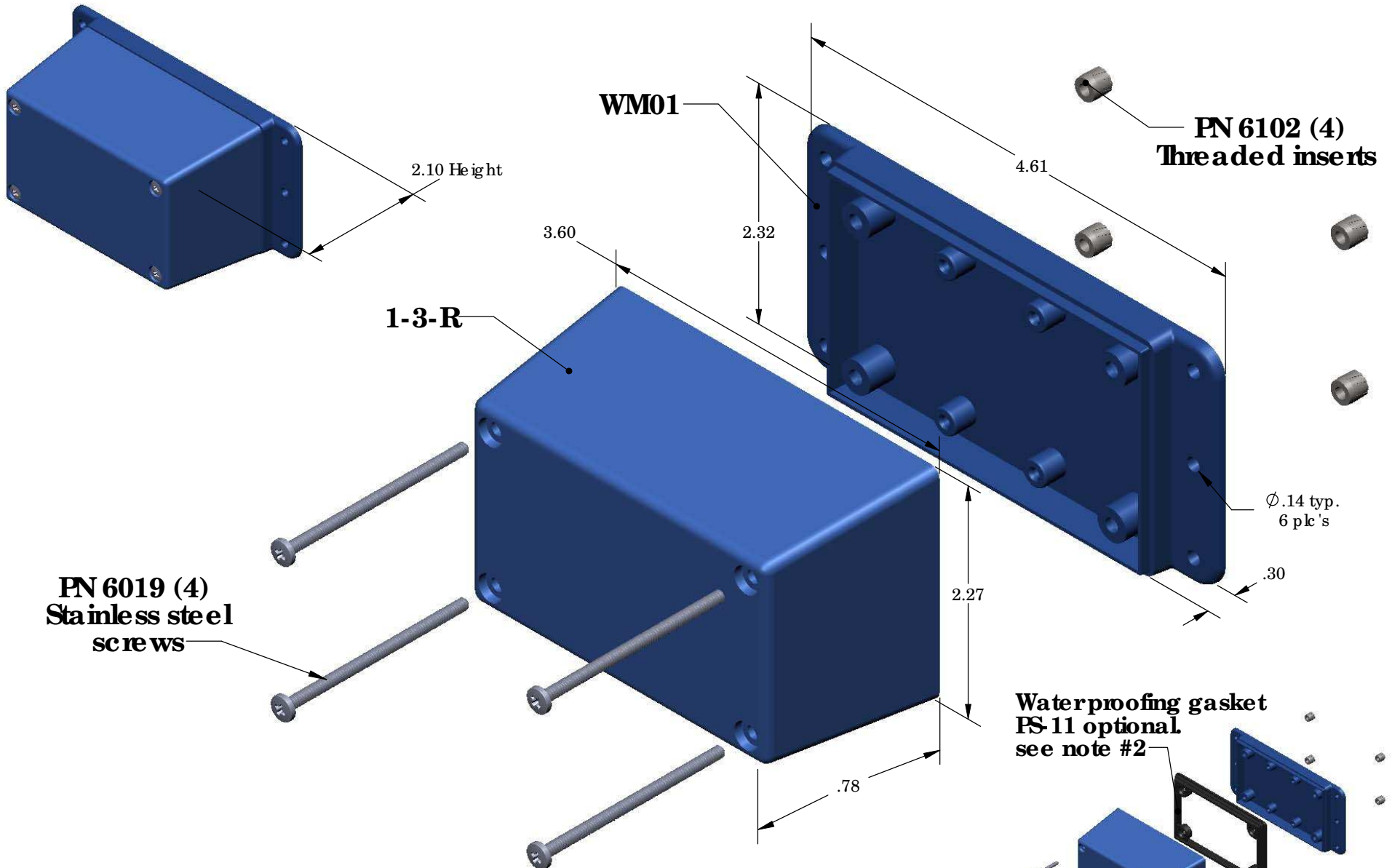

PART NO.	DESCRIPTION (Included)	ACCESSORIES (Optional)	
1-3-R	TOP	PART NO.	DESCRIPTION
WM01	BOTTOM	50	Non-skid Feet
6019	4-40 SCREW (4)	PS-11	Perimeter Seal
6102	THREADED INSERTS (4)	310	Prototype grid board (bottom only)
		410	Prototype clad board (bottom only)

Notes:  
 1) Enclosure meets or exceeds IP40 and NEMA 1  
 2) When used with PS-11 the enclosure meets or exceeds IP 67 and NEMA 4X, 12 and 13 MIL-STD-810G 506.5  
 3) Circuit Board drawings can be downloaded at:  
<http://www.serpac.com/Accessories/CircuitBoard/drawings/310-410.pdf>  
 4) All components are RoHS compliant.

Waterproofing gasket PS-11 optional see note #2

**ALL DIMENSIONS ARE ±.010" 5/7/09 (1 of 2)**  
**619 Commercial Ave. Covina, CA 91723**  
**Ph. (626) 331-0517 Ex. (626) 331-8584 serpac.com**

# SERPAC WM013-R (user print)

Electronic Enclosures

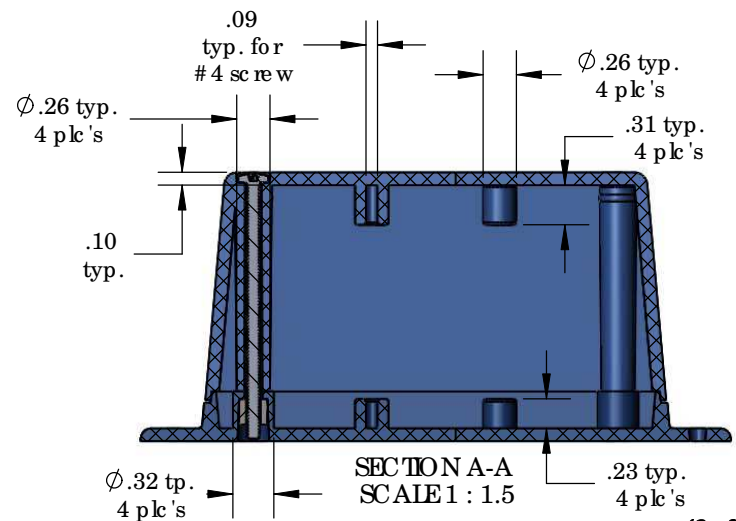
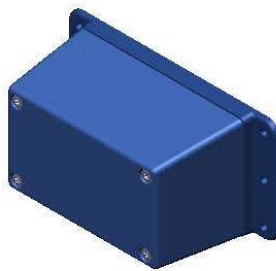
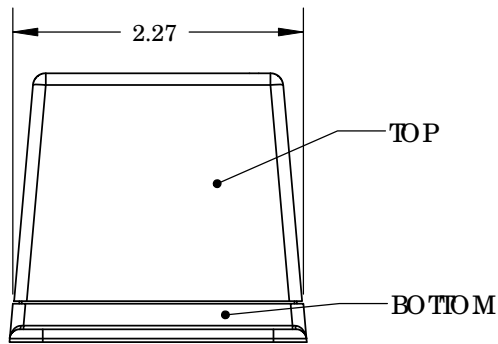
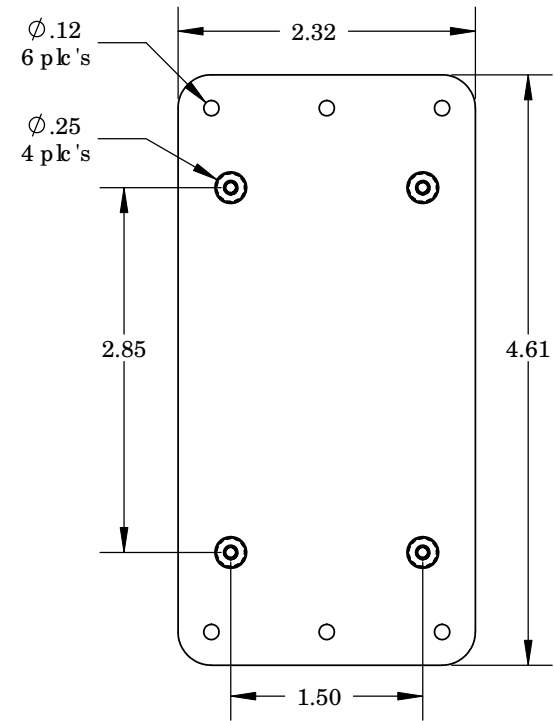
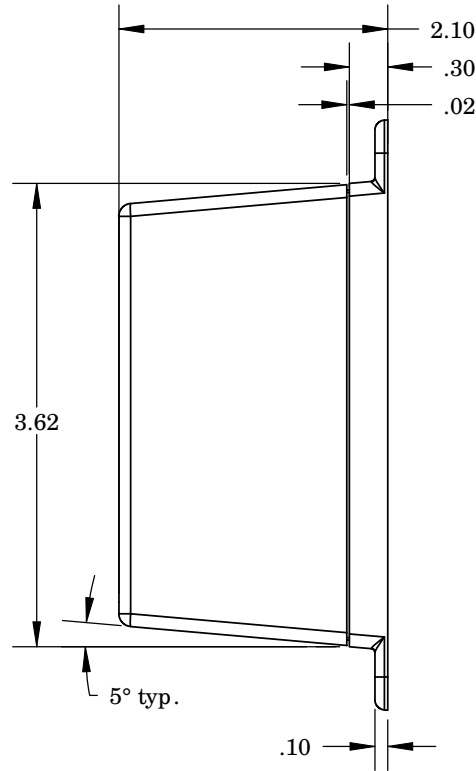
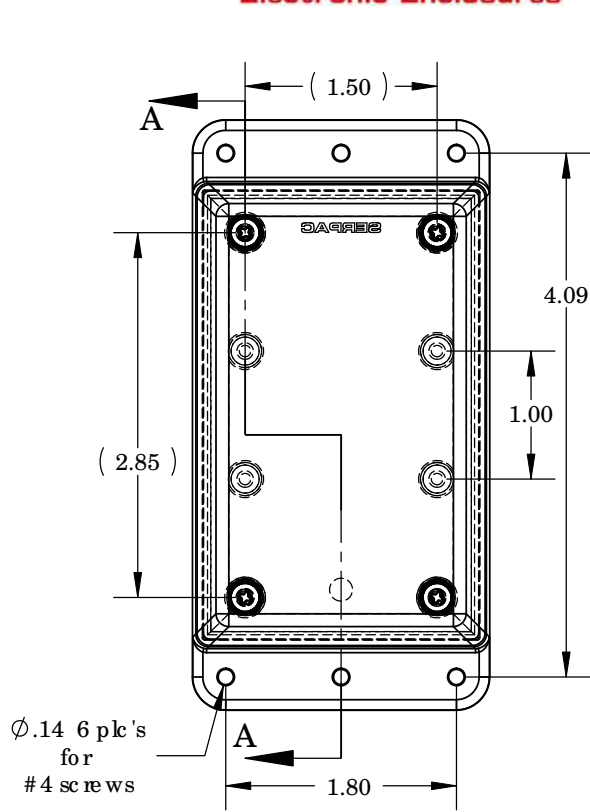

**Notes:**

- 1) Enclosure meets or exceeds IP40 and NEMA 1
- 2) When used with PS-11 the enclosure meets or exceeds IP 67 and NEMA 4X, 12 and 13 MIL-STD-810G 506.5
- 3) Circuit Board drawings can be downloaded at: <http://www.serpac.com/Accessories/CircuitBoard/drawings/310-410.pdf>
- 4) All components are RoHS Compliant.

PART NO.	DESCRIPTION (Included)	ACCESSORIES (Optional)	
1-3-R	TOP	PART NO.	DESCRIPTION
WM01	BOTTOM	50	Non-skid Feet
6019	4-40 SCREW (4)	PS-11	Perimeter Seal
6102	THREADED INSERTS (4)	310	Prototype grid board (bottom only)
		410	Prototype clad board (bottom only)