

# SERPAC 193RC (3D exploded)

Electronic Enclosures

- Click on image to show toolbar. Use ▶|| to Play/Pause Animation\*.
- Left click and drag on image to move 3D model.

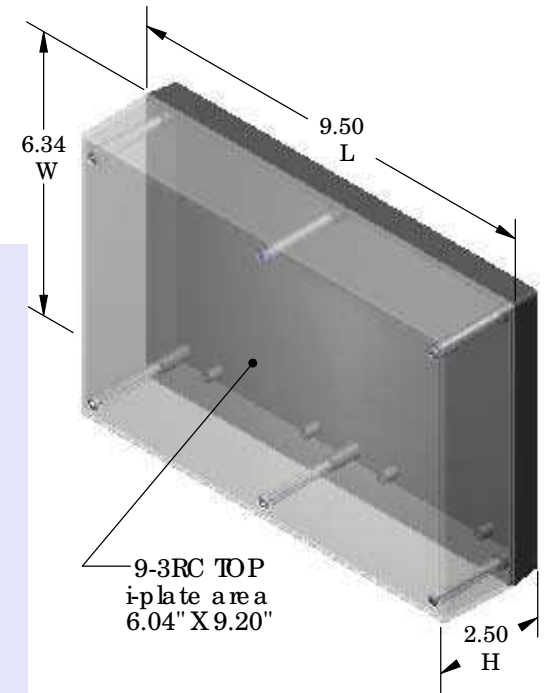
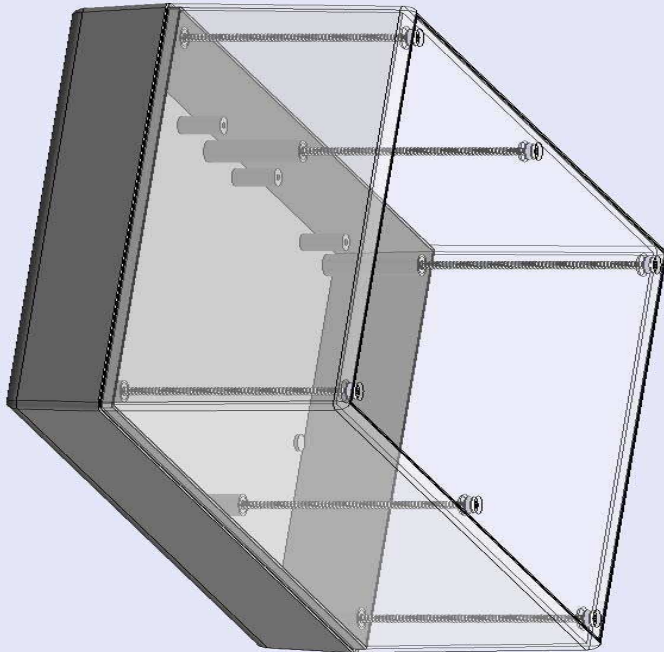

Waterproofing gasket  
PS19 optional  
see note #2

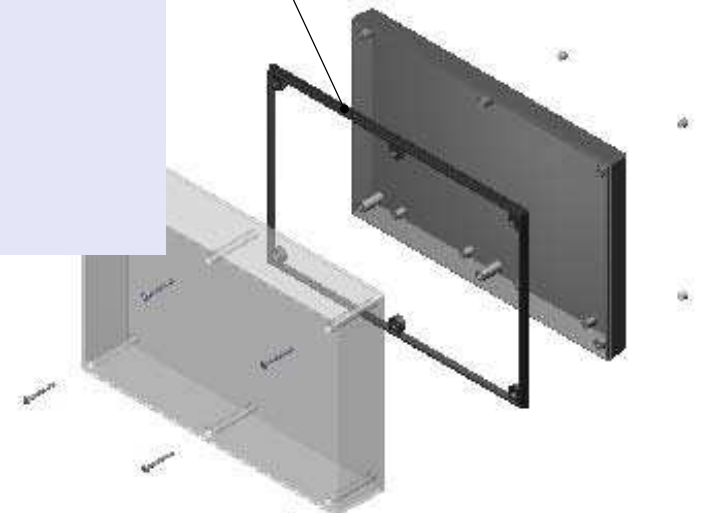

- a) Zoom in & out with center wheel.
  - b) Pause at any moment to view and or print views.
  - c) Change the views to ortho and section views if needed from the Views pull down menu.
  - d) Explore options included in the tool bar like: Views, Transparency of model, Lighting type, etc.
- \*(To have full interaction with the animated PDF files, please use free Adobe Reader 9 or newer version.)

PART NO.	DESCRIPTION (Included)	ACCESSORIES (Optional) More available; see website	
		PART NO.	DESCRIPTION
9-3RC	TOP (Clear Polycarbonate)		
19	BOTTOM	50	Non-skid Feet
6019	4-40 SCREW (6)	PS19	Perimeter Seal
6102	THREADED INSERT	6004	Screw for circuit board

- Notes: Enclosure weight .81 lbs / 368 gm
- 1) Enclosure meets or exceeds IP40 and NEMA 1
  - 2) When used with PS19 the enclosure meets or exceeds IP 67 and NEMA 4X, 12 and 13 MIL-STD-810G 506.5
  - 3) Circuit Board drawings can be downloaded at: <http://www.serpac.com/Products/Series/x9x/drawings/19X-CB.pdf>
  - 4) All components are RoHS compliant.

ALL DIMENSIONS ARE ±.010" 5/13/10 (1 of 2)  
2009 Wright Ave. La Verne, CA 91750  
Ph. (626) 331-0517 Ex. (626) 331-8584 serpac.com

# SERPAC 193RC (user print)

Electronic Enclosures

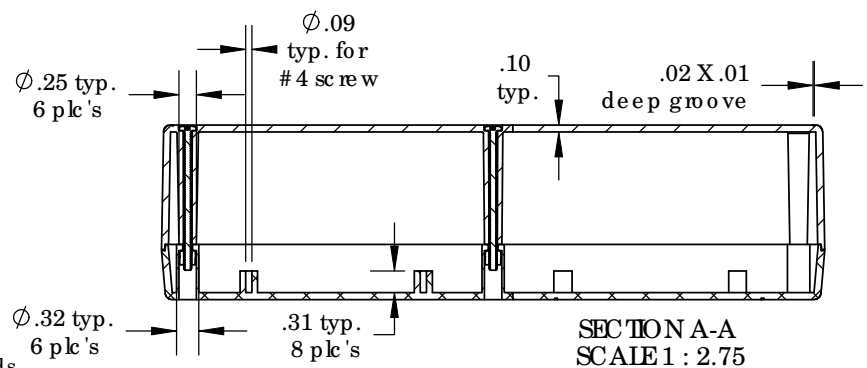
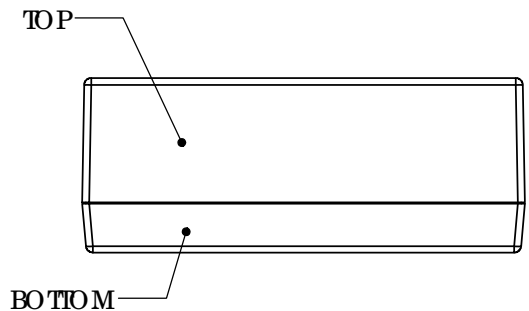
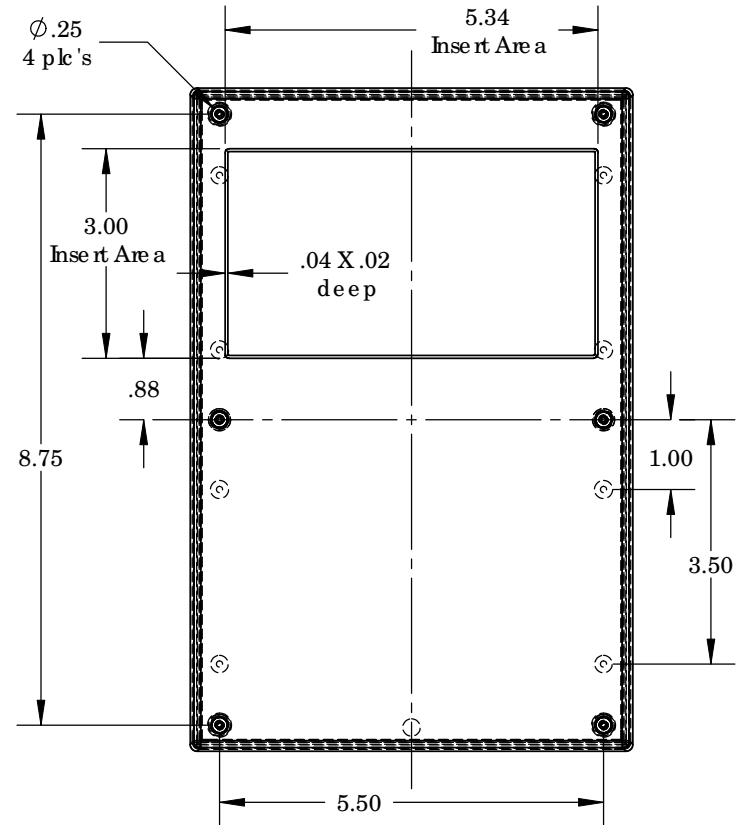
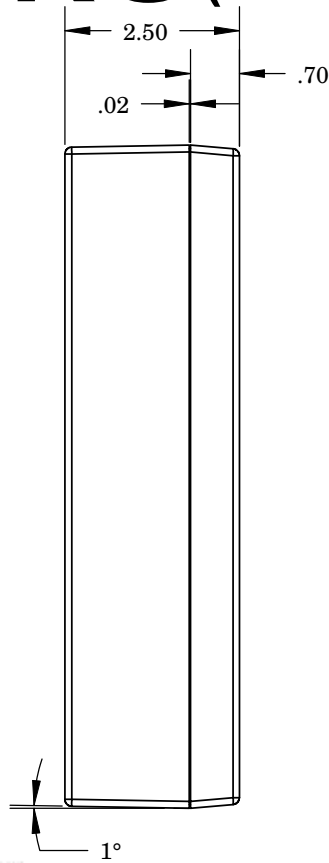
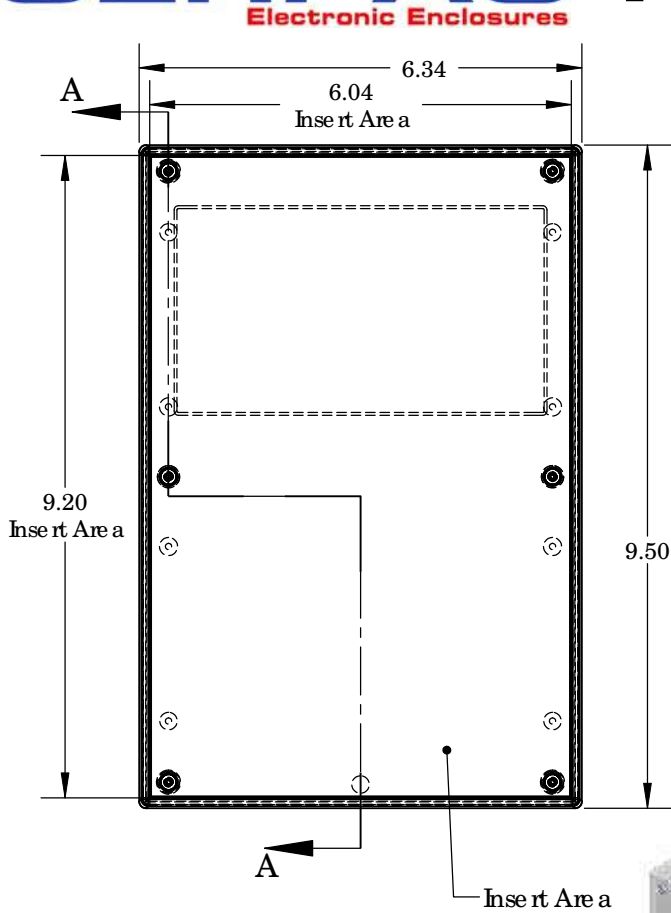

PART NO.	DESCRIPTION (Included)	ACCESSORIES (Optional) More available; see website	
9-3RC	TOP (Clear Polycarbonate)	PART NO.	DESCRIPTION
19	BOTTOM	50	Non-skid Feet
6019	4-40 SCREW (6)	PS19	Perimeter Seal
6102	THREADED INSERT	6004	Screw for circuit board

Notes:  
 Enclosure weight .81 lbs/ 368 gm  
 1) Enclosure meets or exceeds IP40 and NEMA 1  
 2) When used with PS19 the enclosure meets or exceeds IP 67 and NEMA 4X, 12 and 13 MIL-STD-810G 506.5  
 3) Circuit Board drawings can be downloaded at:  
<http://www.sepac.com/Products/Series/x9x/drawings/19X-CB.pdf>  
 4) All components are RoHS compliant.

ALL DIMENSIONS ARE ±.010" 5/13/10 (2 of 2)  
 2009 Wright Ave. La Verne, CA 91750  
 Ph. (626) 331-0517 Ex. (626) 331-8584 www.sepac.com