

SERPAC WM094-I (exploded isometric)

Electronic Enclosures

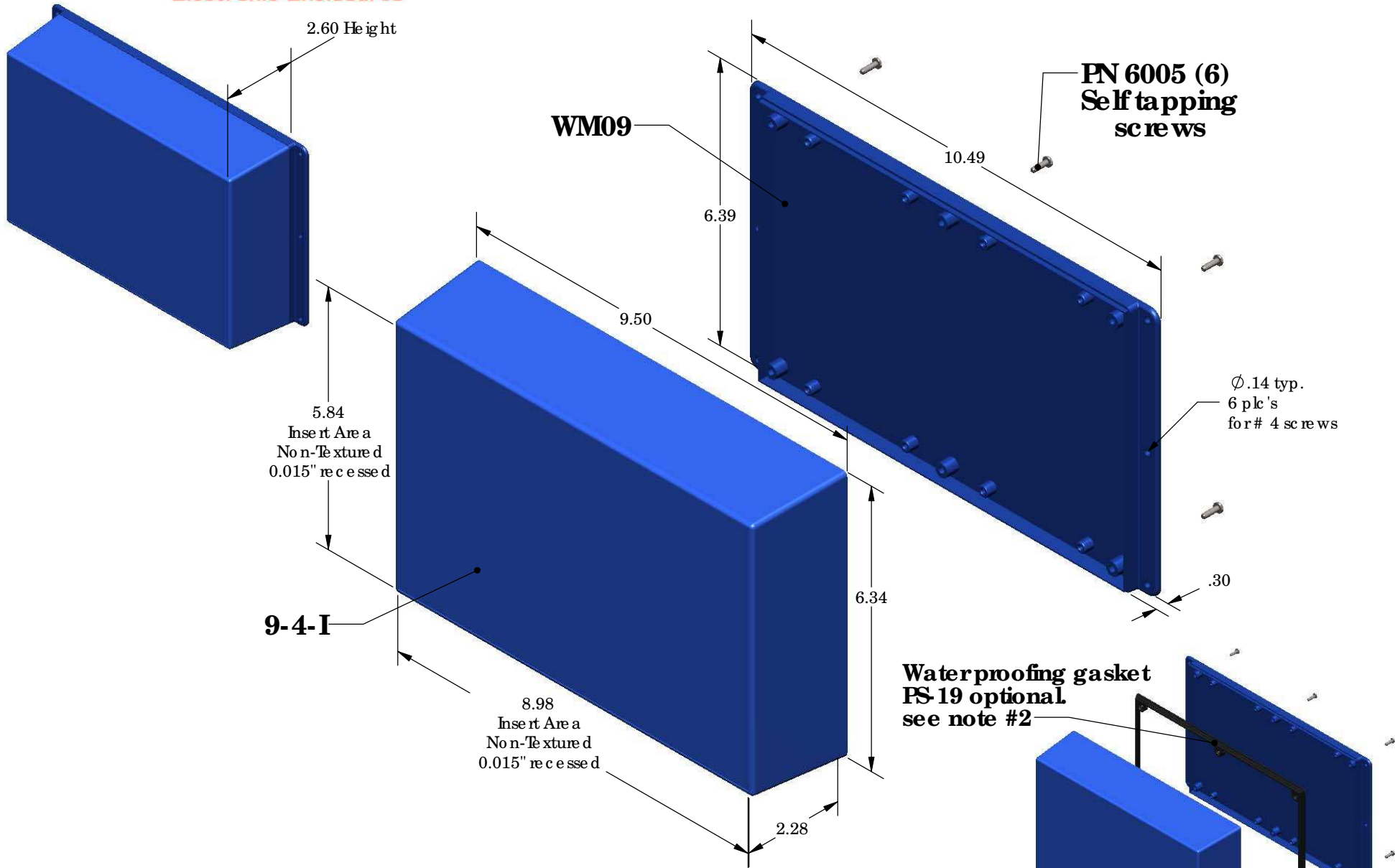

PART NO.	DESCRIPTION (Included)	ACCESSORIES (Optional)	
9-4-I	TOP	PART NO.	DESCRIPTION
WM09	BOTTOM	50	Non-skid Feet
6005	#4 self tapping screw (6)	PS-19	Perimeter Seal

- Notes:
- 1) Enclosure meets or exceeds IP40 and NEMA 1
 - 2) When used with PS-19 the enclosure meets or exceeds IP 67 and NEMA 4X, 12 and 13 MIL-STD-810G 506.5
 - 3) Circuit Board drawings can be downloaded at:
<http://www.serpac.com/Products/Series/x9x/drawings/19X-CB.pdf>
 - 4) All components are RoHS Compliant.

ALL DIMENSIONS ARE ± .010" 9/22/09 (1 of 2)
 619 Commercial Ave. Covina, CA 91723
 Ph. (626) 331-0517 Ex. (626) 331-8584 serpac.com

SERPAC WM094-1 (user print)

Electronic Enclosures

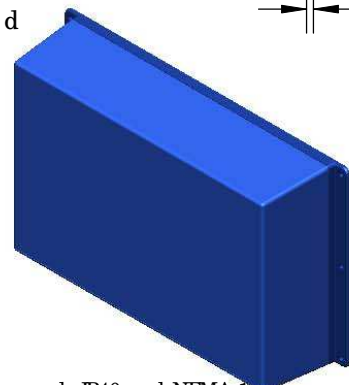
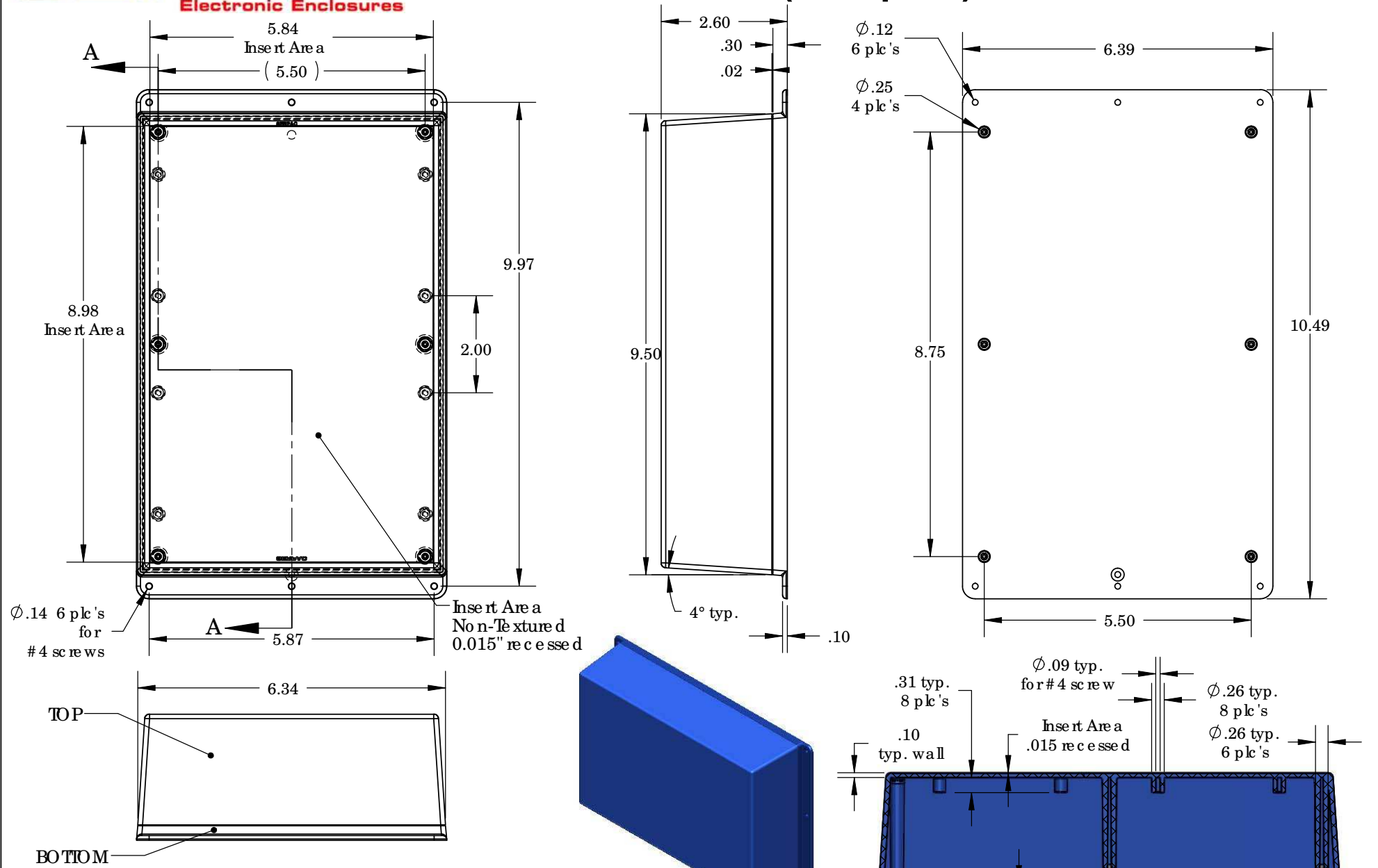

PART NO.	DESCRIPTION (Included)	ACCESORIES (Optional)
9-4-1	TOP	PART NO. DESCRIPTION
WM09	BOTTOM	50 Non-skid Feet
6005	#4 self tapping screw (6)	PS-19 Perimeter Seal

- Notes:
- 1) Enclosure meets or exceeds IP40 and NEMA 1
 - 2) When used with PS-19 the enclosure meets or exceeds IP 67 and NEMA 4X, 12 and 13 MIL-SID-810G 506.5
 - 3) Circuit Board drawings can be downloaded at:
<http://www.serpac.com/Products/Series/x9x/drawings/19X-CB.pdf>
 - 4) All components are RoHS Compliant.

ALL DIMENSIONS ARE ± .010" 9/22/09 (2 of 2)
 619 Commercial Ave. Covina, CA 91723
 Ph. (626) 331-0517 Ex. (626) 331-8584 www.serpac.com