

SERPAC H-75, 4AA

Electronics Enclosures

NOTES:

1. WHEN MACHINE OR I PLATES MODIFICATIONS ARE REQUIRED, USE THE CENTER OF THE ENCLOSURE TO DIMENSION.
2. INTERNAL INSERT AREAS ARE 0.04 PER SIDE LARGER THAN INSERT AREAS

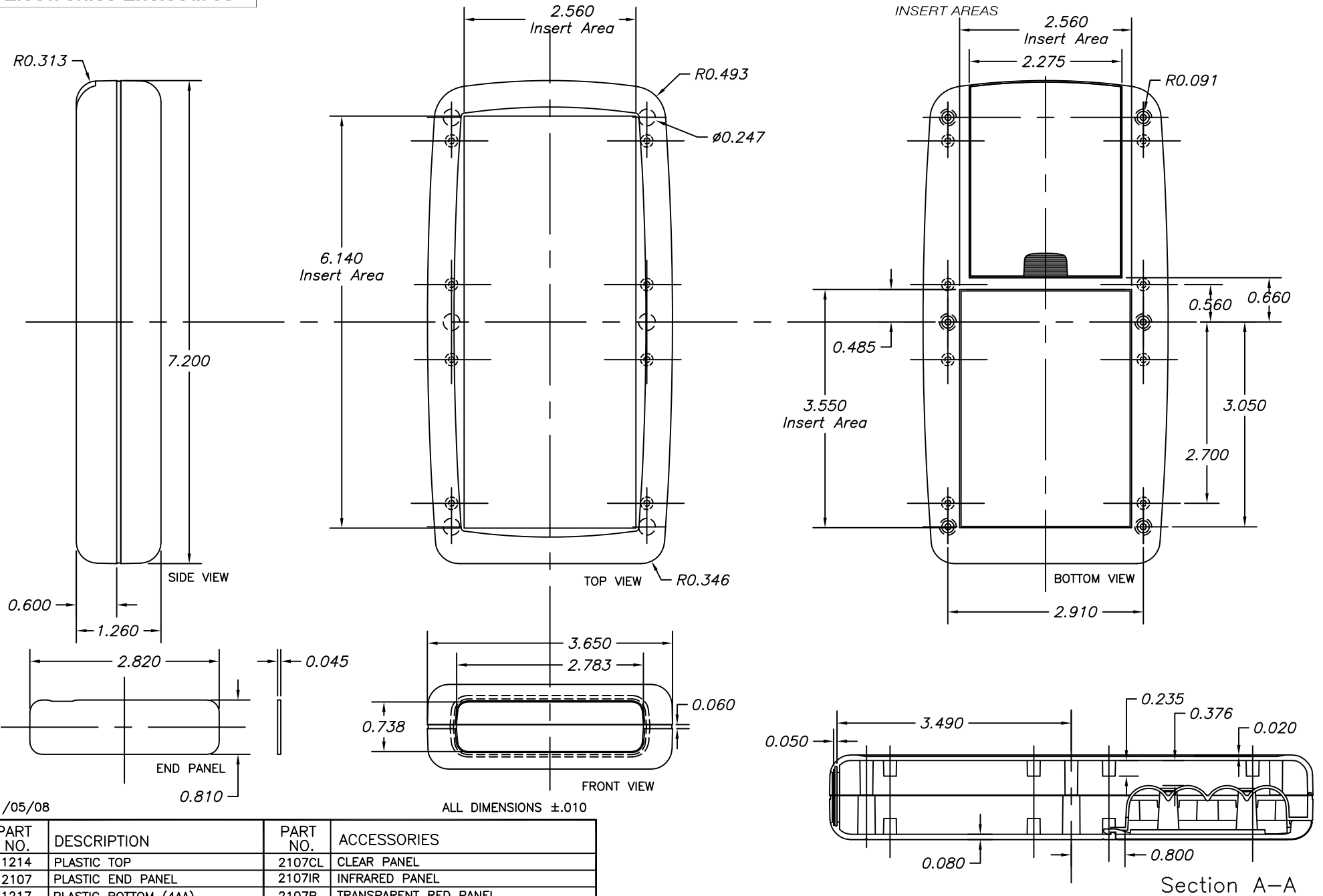

11/05/08

ALL DIMENSIONS ± 0.010

PART NO.	DESCRIPTION	PART NO.	ACCESSORIES
1214	PLASTIC TOP	2107CL	CLEAR PANEL
2107	PLASTIC END PANEL	2107IR	INFRARED PANEL
1217	PLASTIC BOTTOM (4AA)	2107R	TRANSPARENT RED PANEL
1219	PLASTIC BATTERY COVER	PC	POCKET CLIP
6003	SCREW (6)	60	STANDOFF HOLES
72	BATTERY CONTACT-SINGLE (2)	61	STANDOFF POSTS
73	BATTERY CONTACT- DOUBLE (3)		

619 Commercial Ave. Covina, CA 91723

(626) 331-0517 Fax (626) 331-8584 <http://www.serpac.com>