

SERPAC 152R (3D exploded)

Electronic Enclosures

-Click on image to show toolbar. Use ▶|| to Play/Pause Animation.
 -Left click and drag on image to move 3D model.

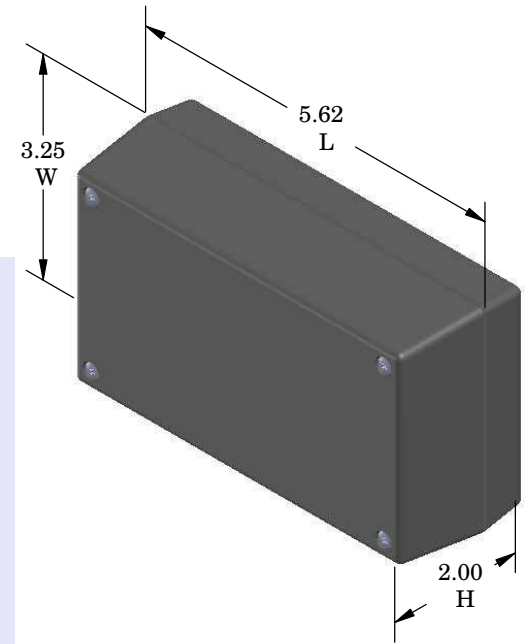
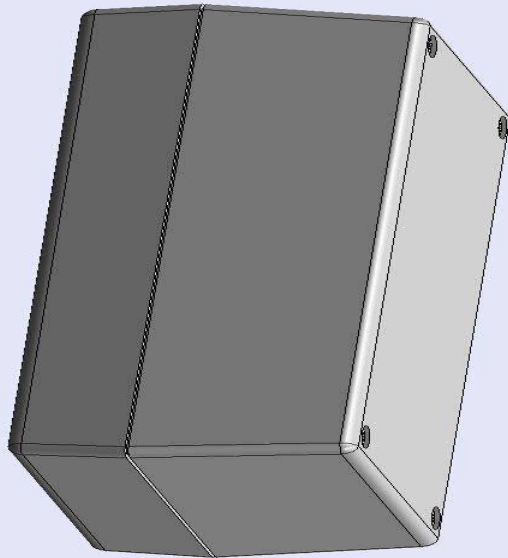

Threaded inserts only have to be assembled the first time.

Waterproofing gasket
 PS15 optional
 see note #2

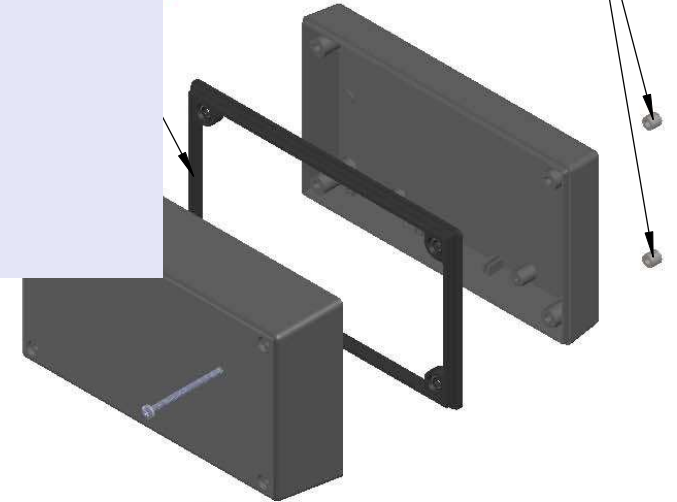

- a) Zoom in & out with center wheel.
- b) Pause at any moment to view and or print views.
- c) Change the views to ortho and section views if needed from the Views pull down menu.
- d) Explore options included in the tool bar like: Views, Transparency of model, Lighting type, etc.

PART NO.	DESCRIPTION (Included)	ACCESSORIES (Optional)	
5-2R	TOP	PART NO.	DESCRIPTION
15	BOTTOM	PS15	Perimeter Seal
6018	4-40 SCREW (4)	350	Prototype Grid Circuit Board
6102	THREADED INSERTS (4)	450	Prototype Clad Circuit Board

Notes: Enclosure weight .28 lbs/ 125 gm
 1) Enclosure meets or exceeds IP40 and NEMA 1
 2) When used with PS15 the enclosure meets or exceeds IP 67 and NEMA 4X, 12 and 13 MIL-SID-810G 506.5
 3) Circuit Board drawings can be downloaded at:
<http://www.serpac.com/Accessories/CircuitBoard/drawings/350-450-cbg.pdf>
 4) All components are RoHS Compliant.

ALL DIMENSIONS ARE ±.010" 7/29/10 (1 of 2)
 2009 Wright Ave. La Verne, CA 91750
 Ph. (626) 331-0517 Ex. (626) 331-8584 serpac.com

SERPAC 152R (user print)

Electronic Enclosures

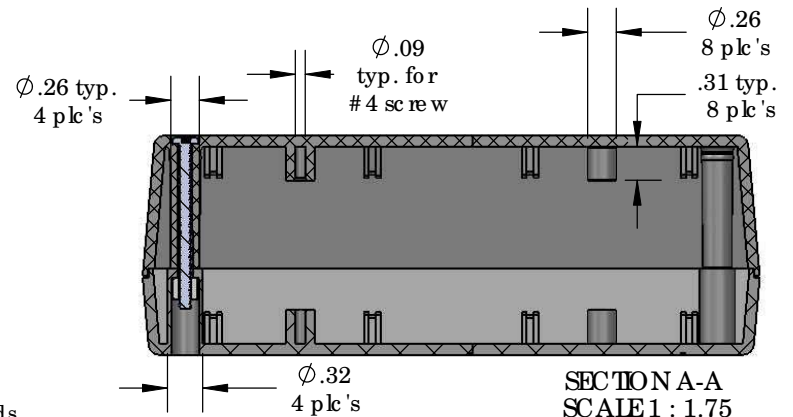
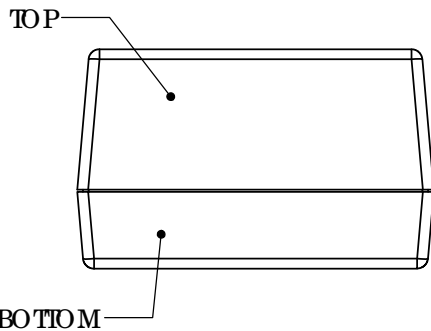
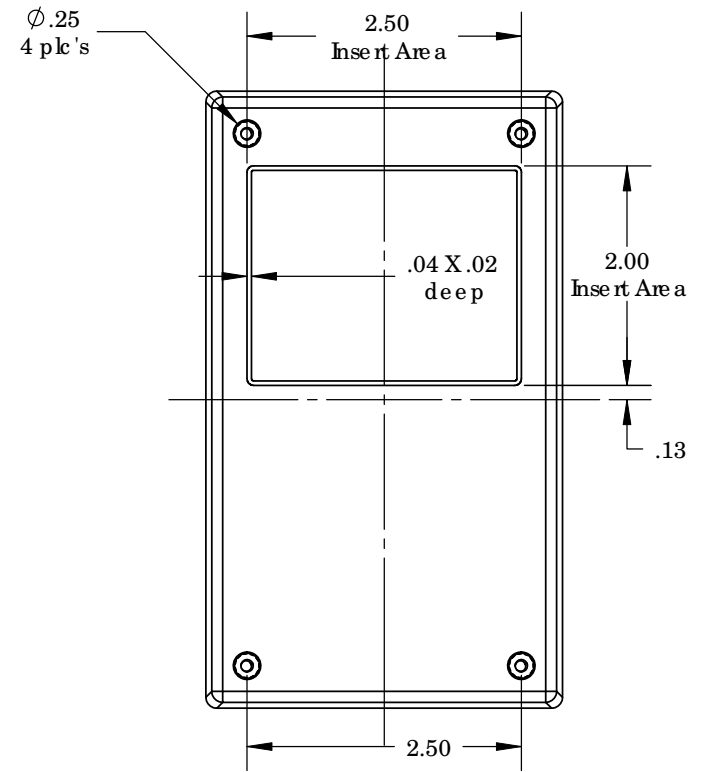
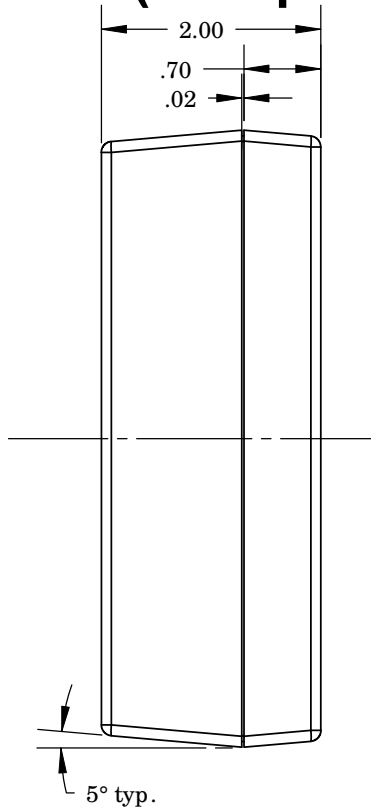
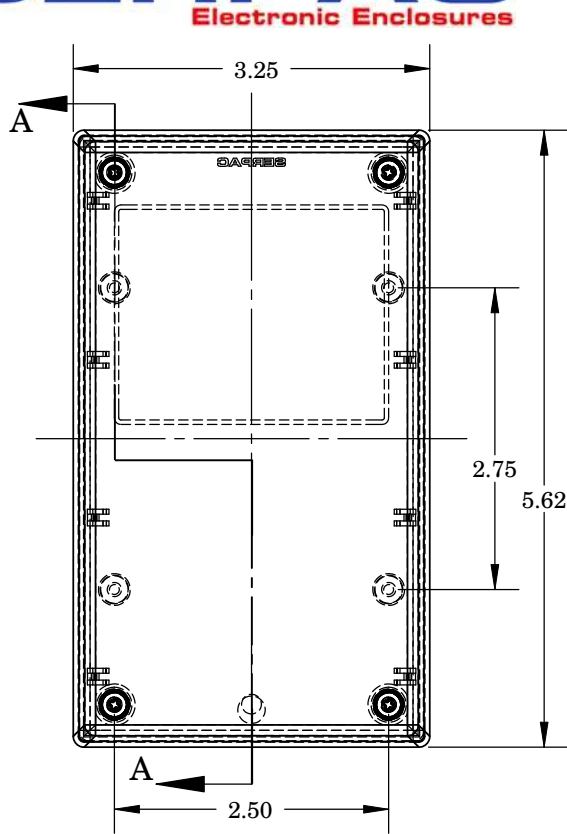

PART NO.	DESCRIPTION (Included)	ACCESSORIES (Optional)	
5-2R	TOP	PART NO.	DESCRIPTION
15	BOTTOM	PS15	Perimeter Seal
6018	4-40 SCREW (4)	350	Prototype Grid Circuit Board
6102	THREADED INSERTS (4)	450	Prototype Clad Circuit Board

- Notes: Enclosure weight .28 lbs/ 125 gm
- 1) Enclosure meets or exceeds IP40 and NEMA 1
 - 2) When used with PS15 the enclosure meets or exceeds IP 67 and NEMA 4X, 12 and 13 MIL-STD-810G 506.5
 - 3) Circuit Board drawings can be downloaded at: <http://www.serpac.com/Accessories/CircuitBoard/drawings/350-450-cbg.pdf>
 - 4) All components are RoHS Compliant.

ALL DIMENSIONS ARE ± .010" 7/29/10 (2 of 2)
 2009 Wright Ave. La Verne, CA 91750
 Ph. (626) 331-0517 Ex. (626) 331-8584 www.serpac.com