

# SERPAC 151Ri (3D exploded)

Electronic Enclosures

-Click on image to show toolbar. Use  to Play/Pause Animation.  
-Left click and drag on image to move 3D model.

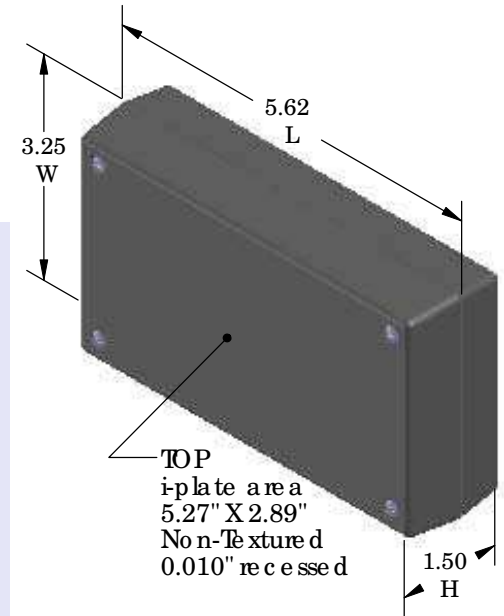
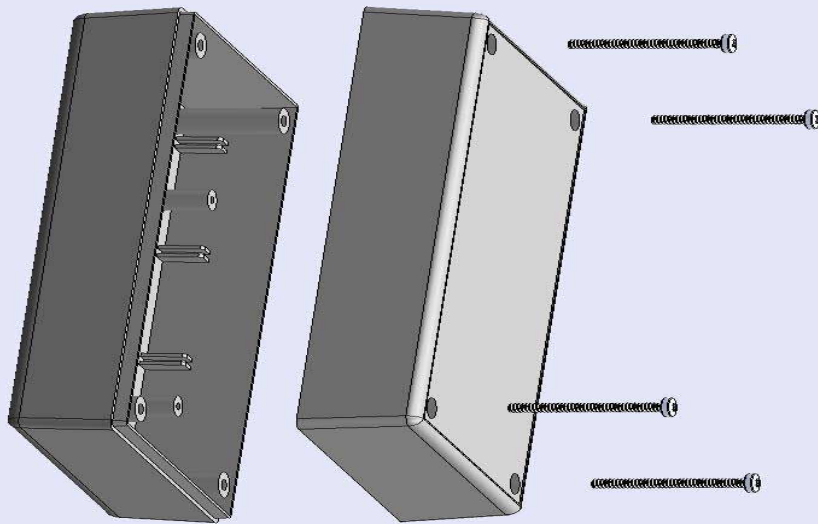

Threaded inserts only have to be assembled the first time.

Perimeter sealing gasket PS15 optional see note #2

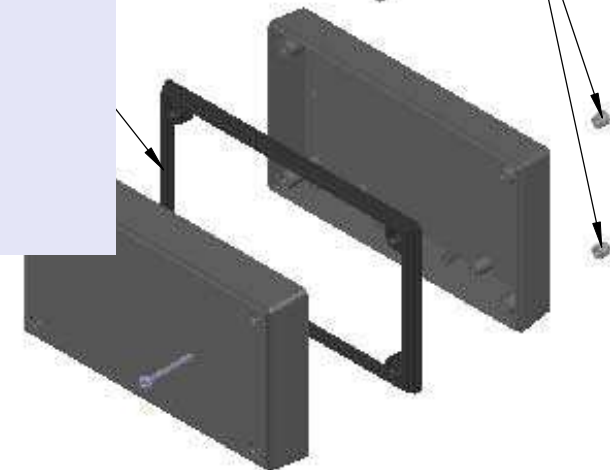

- a) Zoom in & out with center wheel.
- b) Pause at any moment to view and or print views.
- c) Change the views to ortho and section views if needed from the Views pull down menu.
- d) Explore options included in the tool bar like: Views, Transparency of model, Lighting type, etc.

PART NO.	DESCRIPTION (Included)	ACCESSORIES (Optional)	
5-1Ri	TOP	PART NO.	DESCRIPTION
15	BOTTOM	PS15	Perimeter Seal
6017	4-40 SCREW (4)	350	Prototype Grid Circuit Board
6102	THREADED INSERTS (4)	450	Prototype Clad Circuit Board

Notes: Enclosure weight .25 lbs/ 112 gm  
 1) Enclosure meets or exceeds IP40 and NEMA 1  
 2) When used with PS15 the enclosure meets or exceeds IP 67 and NEMA 4X, 12 and 13 MIL-SID-810G 506.5  
 3) Circuit Board drawings can be downloaded at:  
<http://www.serpac.com/Accessories/CircuitBoard/drawings/350-450-cbg.pdf>  
 4) All components are RoHS Compliant.

ALL DIMENSIONS ARE ±.010" 7/29/10 (1 of 2)  
 2009 Wright Ave. La Verne, CA 91750  
 Ph. (626) 331-0517 Ex. (626) 331-8584 serpac.com

# SERPAC 151Ri (user print)

Electronic Enclosures

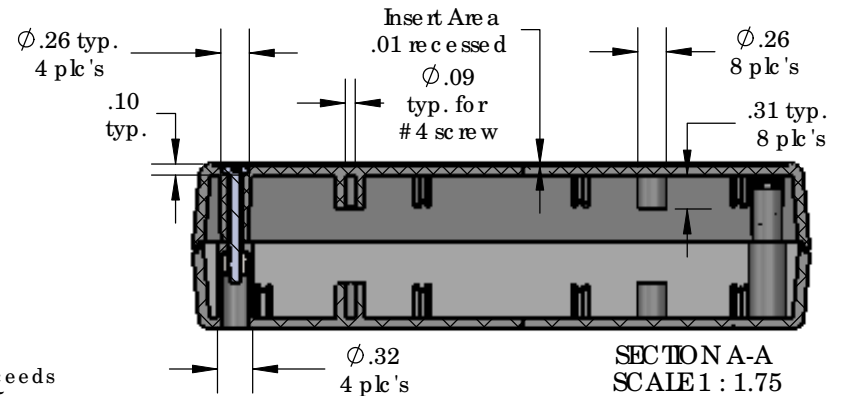
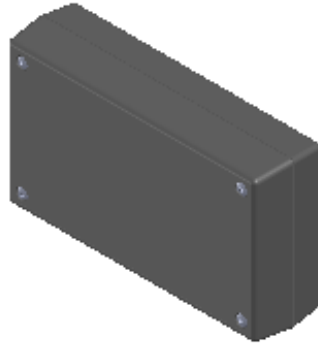
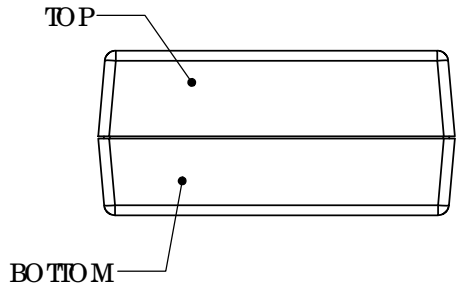
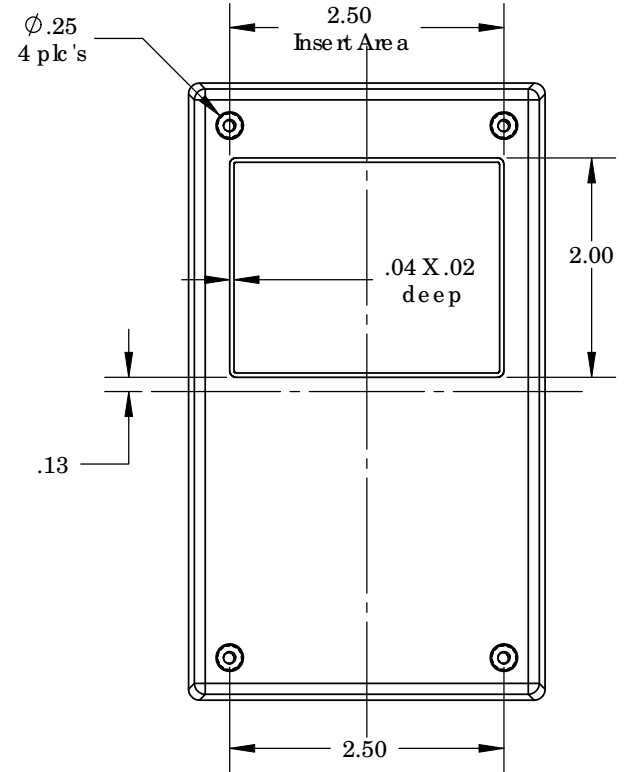
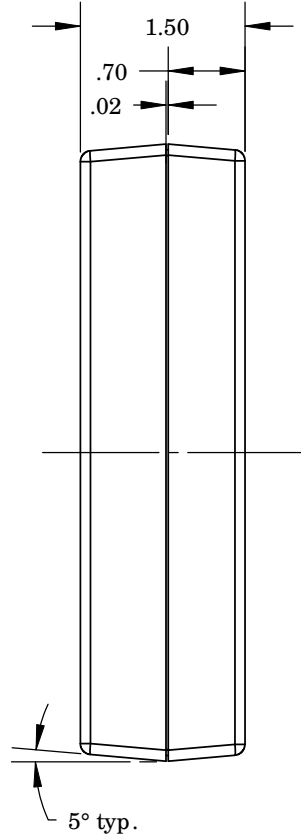
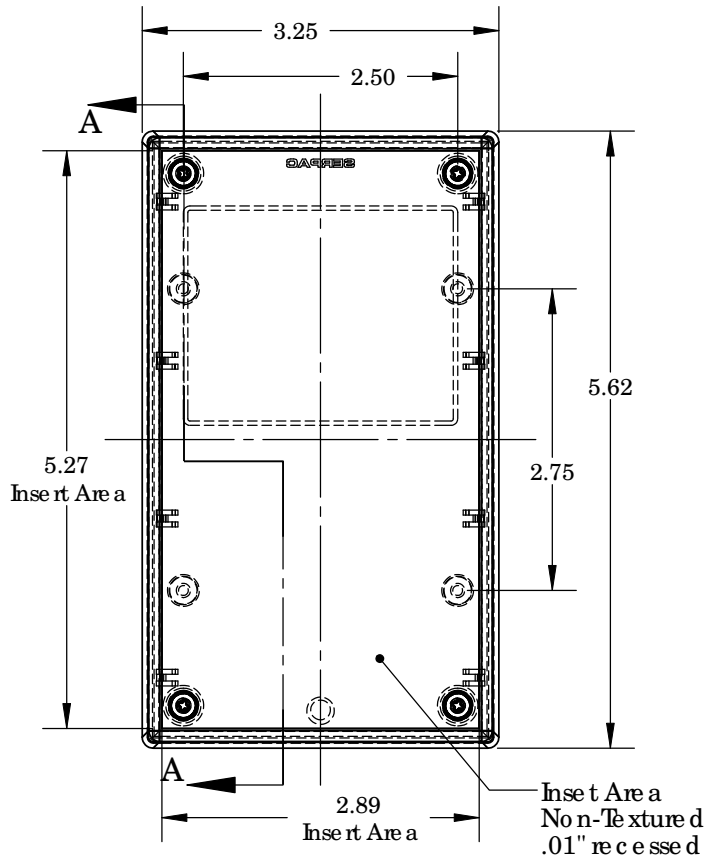

PART NO.	DESCRIPTION (Included)	ACCESSORIES (Optional)	
5-1Ri	TOP	PART NO.	DESCRIPTION
15	BOTTOM	PS 15	Perimeter Seal
6017	4-40 SCREW (4)	350	Prototype Grid Circuit Board
6102	THREADED INSERTS (4)	450	Prototype Clad Circuit Board

- Notes:
- 1) Enclosure weight .25 lbs/ 112 gm
  - 2) When used with PS15 the enclosure meets or exceeds IP 67 and NEMA 4X, 12 and 13 MIL-STD-810G 506.5
  - 3) Circuit Board drawings can be downloaded at: <http://www.serpac.com/Accessories/CircuitBoard/drawings/350-450-cbg.pdf>
  - 4) All components are RoHS Compliant.

ALL DIMENSIONS ARE ± .010" 7/29/10 (2 of 2)  
 2009 Wright Ave. La Verne, CA 91750  
 Ph. (626) 331-0517 Ex. (626) 331-8584 www.serpac.com