

SERPAC 052C (3D exploded)

Electronic Enclosures

- Click on image to show toolbar. Use ▶ || to Play/Pause Animation*.
- Left click and drag on image to move 3D model.

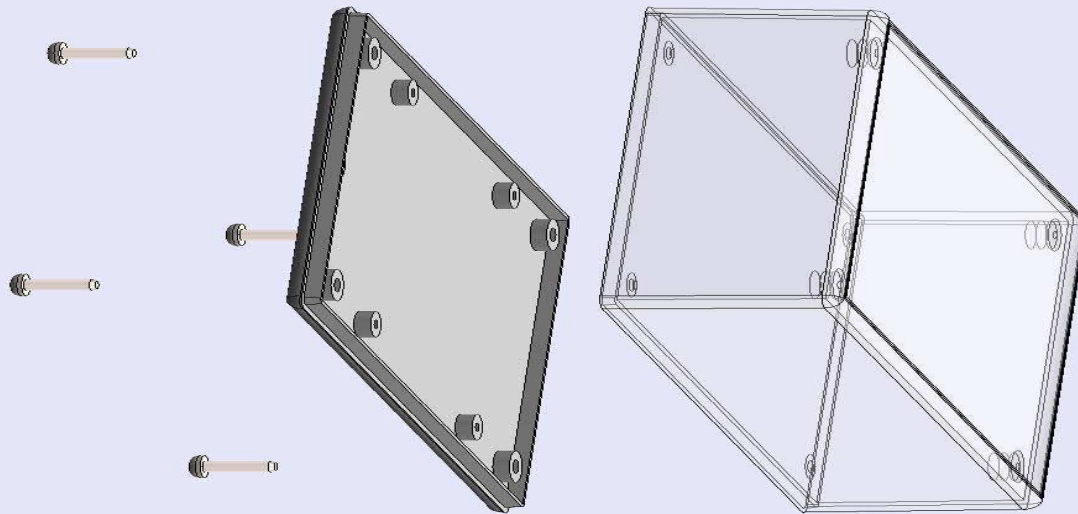
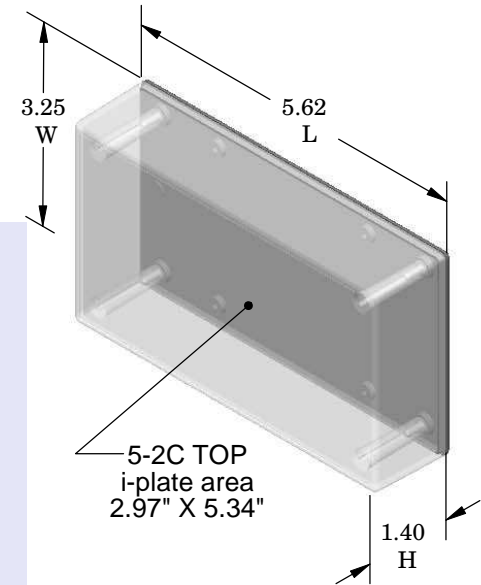

- a) Zoom in & out with center wheel.
 - b) Pause at any moment to view and or print views.
 - c) Change the views to ortho and section views if needed from the Views pull down menu.
 - d) Explore options included in the tool bar like: Views, Transparency of model, Lighting type, etc.
- * To have full interaction with the PDF files, please use free Adobe Reader 9 or newer version.

Notes: Enclosure weight .25 lbs / 112 gm

- 1) Enclosure meets or exceeds IP40 and NEMA 1
- 2) Circuit Board drawings can be download at:

<http://www.serpac.com/Accessories/CircuitBoard/drawings/350-450-cbg.pdf>

- 3) All components are RoHS Compliant.

PART NO.	DESCRIPTION (Included)	ACCESSORIES (Optional) More available; see website	
5-2C	TOP (Clear Polycarbonate)	PART NO.	DESCRIPTION
05	BOTTOM	51	Non-skid Feet
6005	#4X3/8" Self tapping (4)	350	Prototype grid board
		450	Prototype clad board
		6013	Screw for circuit board

ALL DIMENSIONS ARE ±.010" 5/20/10 (1 of 2)
 2009 Wright Ave. La Verne, CA 91750
 Ph. (626) 331-0517 Ex. (626) 331-8584 serpac.com

SERPAC 052C (user print)

Electronic Enclosures

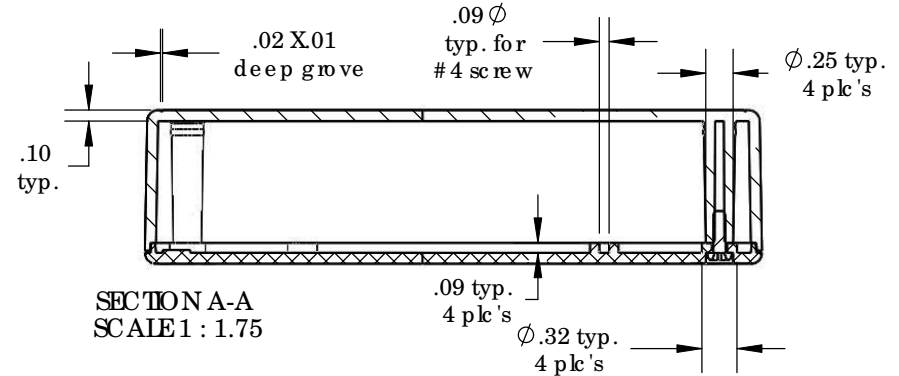
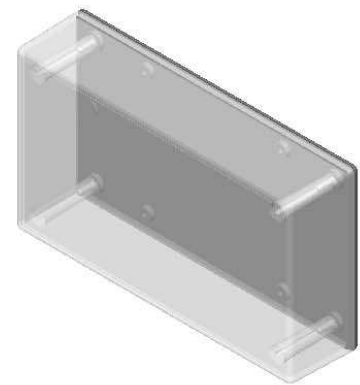
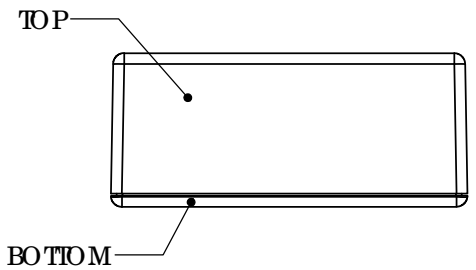
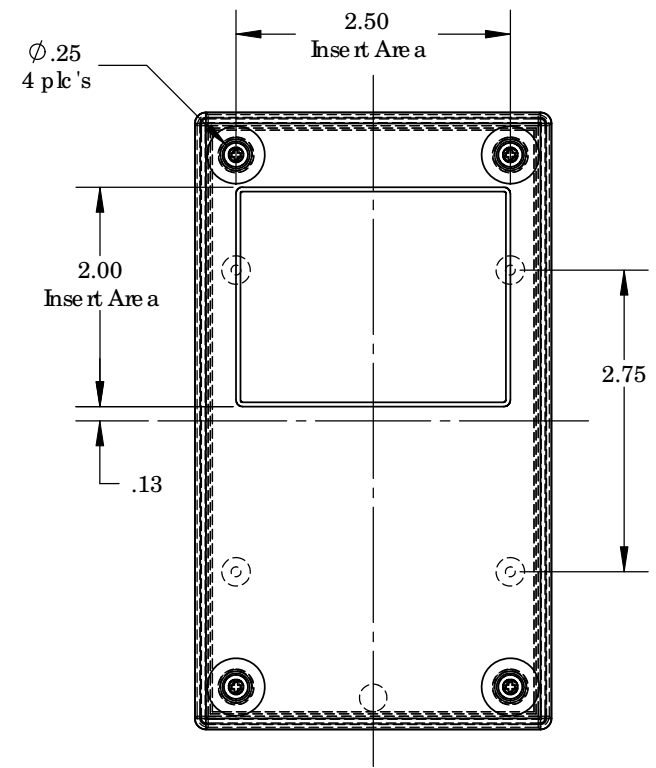
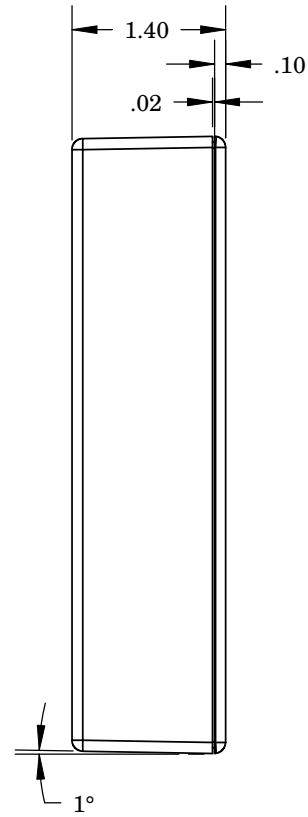
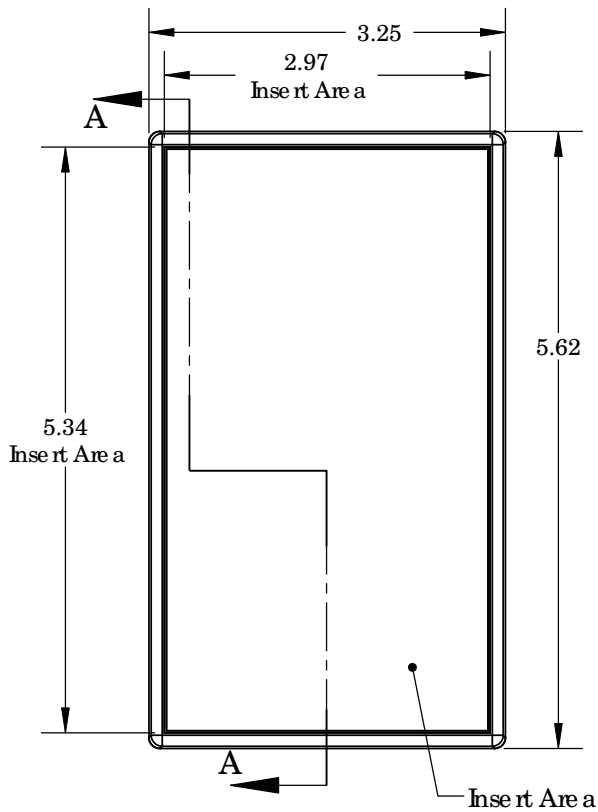

SECTION A-A
SCALE 1 : 1.75

PART NO.	DESCRIPTION (Included)	ACCESSORIES (Optional) More available; see website	
		PART NO.	DESCRIPTION
5-2C	TOP (Clear Polycarbonate)		
05	BOTTOM	51	Non-skid Feet
6005	#4X3/8" self tapping (4)	350	Prototype grid board
		450	Prototype clad board
		6013	Screw for circuit board

Notes: Enclosure weight .25 lbs / 112 gm
 1) Enclosure meets or exceeds IP40 and NEMA 1
 2) Circuit Board drawings can be downloaded at:
<http://www.serpac.com/Accessories/CircuitBoard/drawings/350-450-cbg.pdf>
 3) All components are RoHS compliant.