

SERPAC 051i (exploded isometric)

Electronic Enclosures

- Click on image to show toolbar. Use ▶ || to Play/Pause Animation.
- Left click and drag on image to move 3D model.

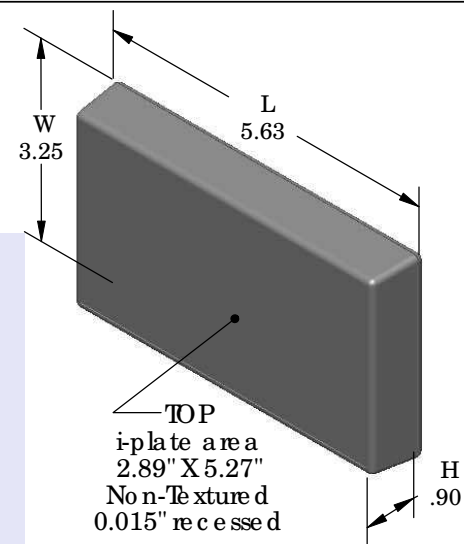
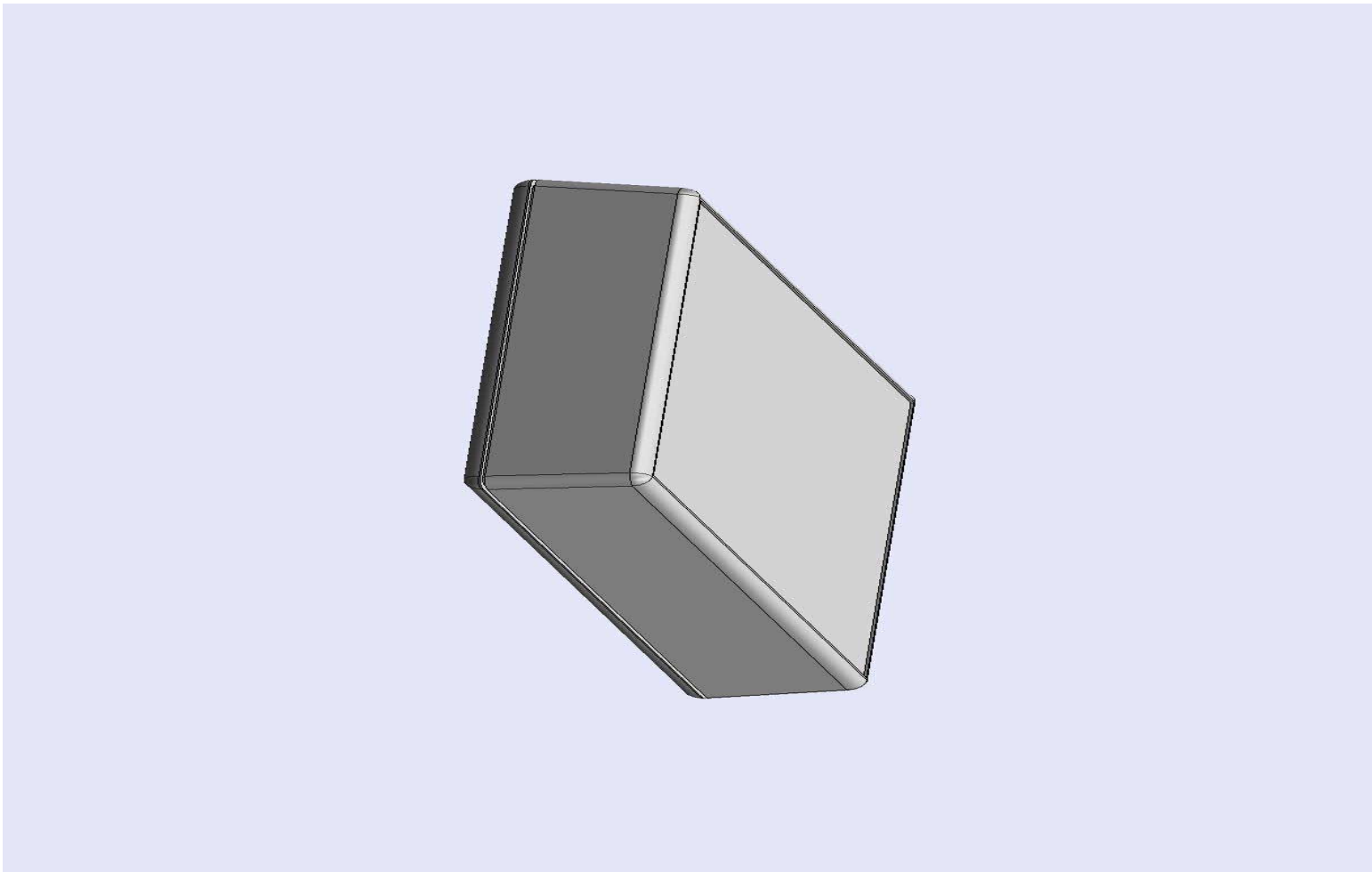

- a) Zoom in & out with center wheel.
- b) Pause at any moment to view and or print views.
- c) Change the views to ortho and section views if needed from the Views pull down menu.
- d) Explore options included in the tool bar like: Views, Transparency of model, Lighting type, etc.

PART NO.	DESCRIPTION (Included)	ACCESSORIES (Optional)	
5-1-i	TOP	PART NO.	DESCRIPTION
05	BOTTOM	51	Non-skid Feet
6005	#4X3/8" Self tapping (4)	350	Prototype grid board
		450	Prototype clad board

Notes: Enclosure weight .19 lbs / 89 gm

1) Enclosure meets or exceeds IP40 and NEMA 1

2) Circuit Board drawings can be download at:

<http://www.serpac.com/Accessories/CircuitBoard/drawings/350-450-cbg.pdf>

3) All components are RoHS Compliant.

ALL DIMENSIONS ARE ±.010" 3/17/10 (1 of 2)

619 Commercial Ave. Covina, CA 91723

Ph. (626) 331-0517 Ex. (626) 331-8584 serpac.com

SERPAC 051i (user print)

Electronic Enclosures

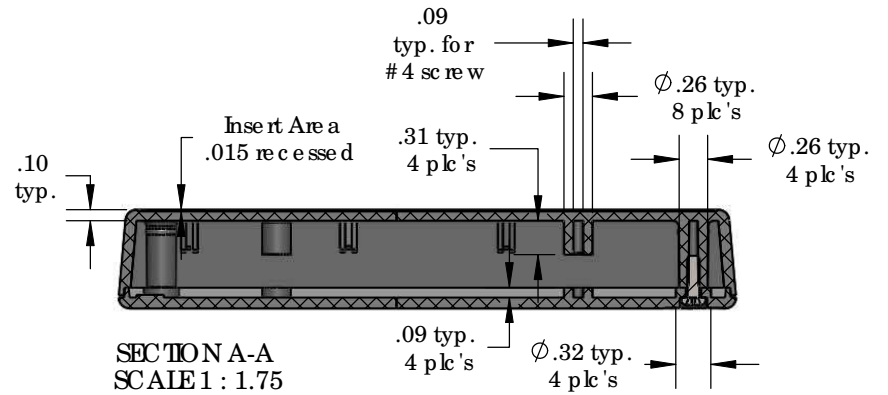
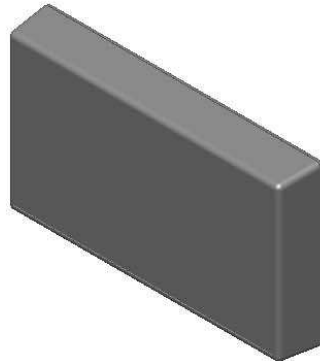
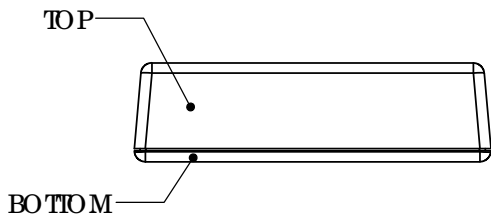
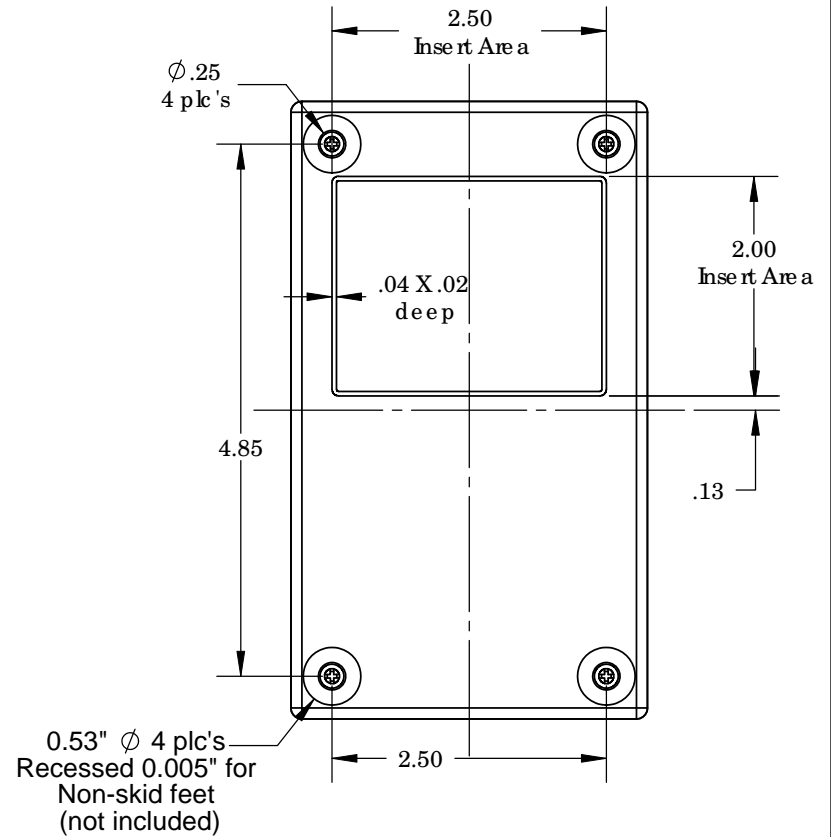
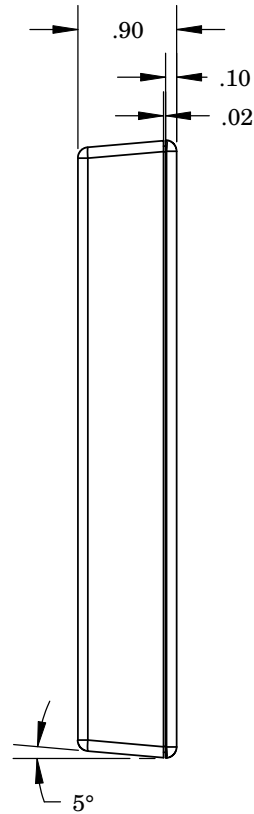
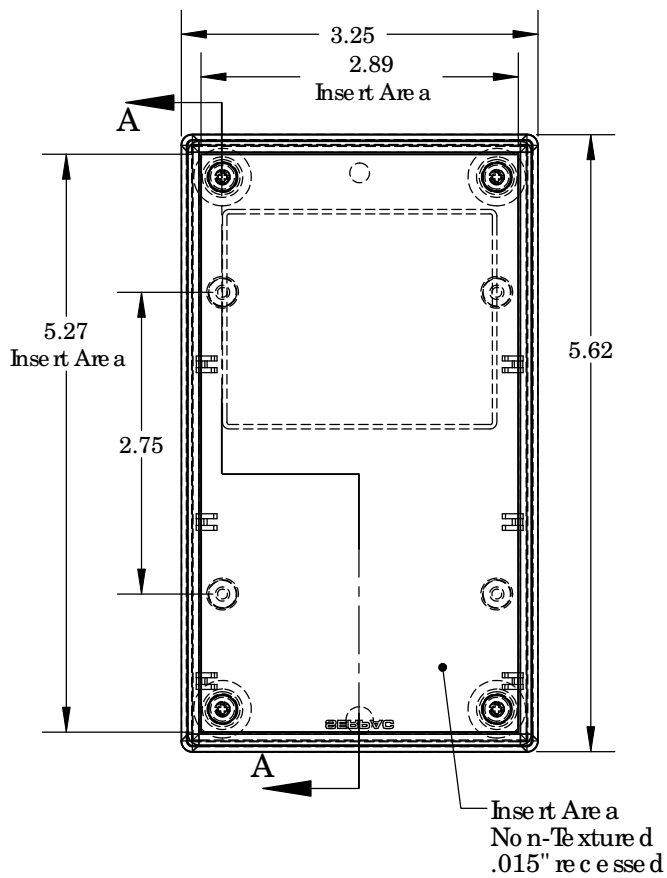

PART NO.	DESCRIPTION (Included)	ACCESSORIES (Optional)	
5-1-i	TOP	PART NO.	DESCRIPTION
05	BOTTOM	51	Non-skid Feet
6005	#4X3/8" self tapping (4)	350	Prototype grid board
		450	Prototype clad board

Notes: Enclosure weight .19 lbs / 89 gm
 1) Enclosure meets or exceeds IP40 and NEMA 1
 2) Circuit Board drawings can be downloaded at:
<http://www.sepac.com/Accessories/CircuitBoard/drawings/350-450-cbg.pdf>
 3) All components are RoHS Compliant.

ALL DIMENSIONS ARE $\pm .010"$ 3/17/10 (2 of 2)
 619 Commercial Ave. Covina, CA 91723
 Ph. (626) 331-0517 Ex. (626) 331-8584 www.sepac.com