

SERPAC H-67,9V

Electronics Enclosures

NOTES:

1. WHEN MACHINE OR I PLATES MODIFICATIONS ARE REQUIRED, USE THE CENTER OF THE BOX TO DIMENSION.

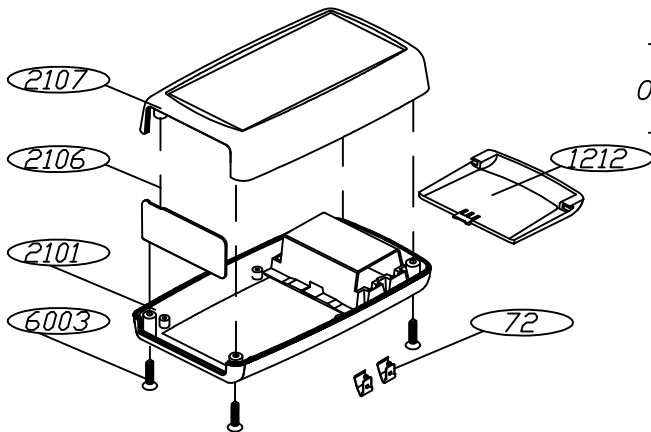
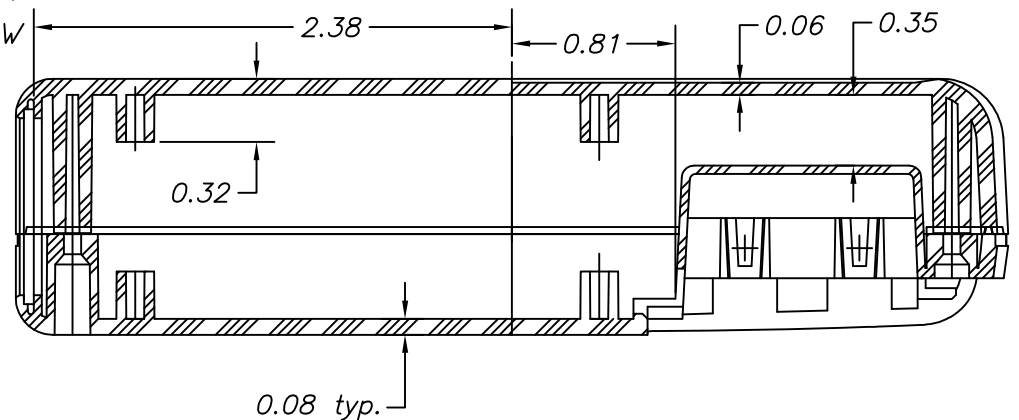
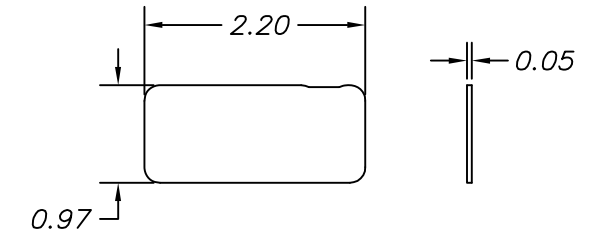
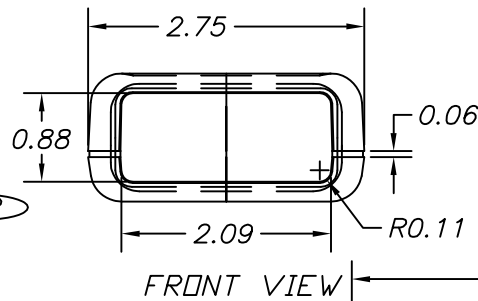
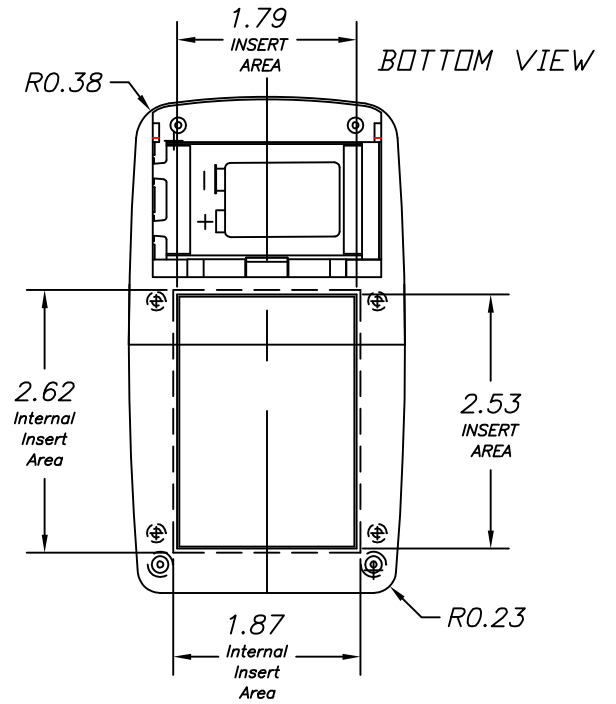
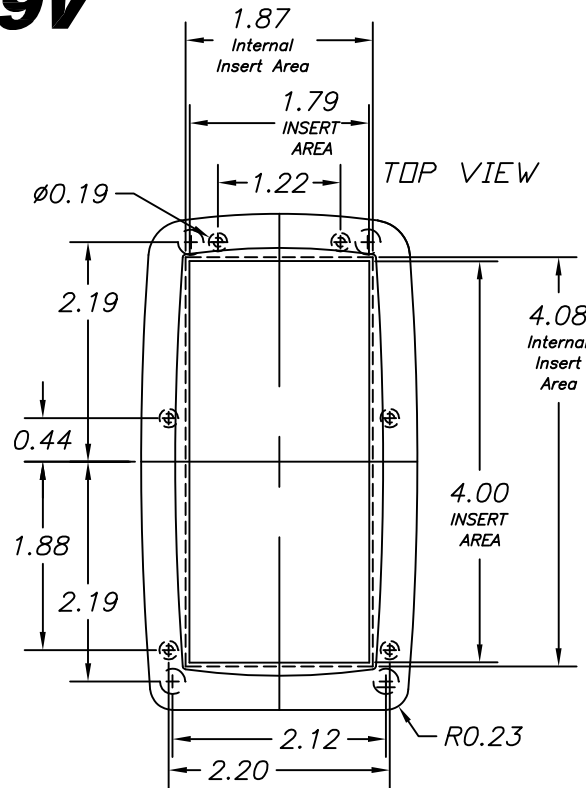
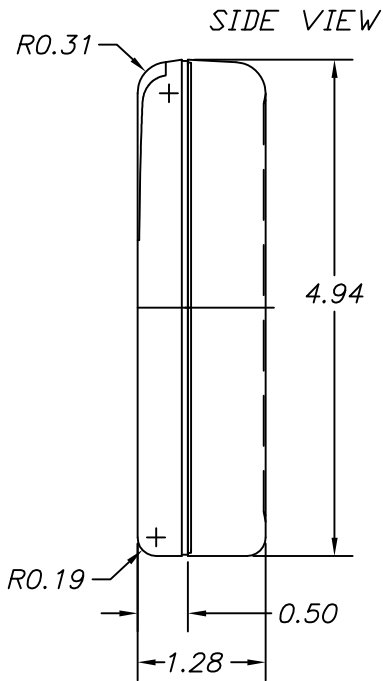

5/08/08.

ALL DIMENSIONS ±0.10

PART NO.	DESCRIPTION	PART NO.	ACCESSORIES
2107	PLASTIC TOP	2106CL	CLEAR PANEL
2106	PLASTIC END PANEL	2106IR	INFRARED PANEL
2103	PLASTIC BOTTOM (9V)	2106R	TRANSPARENT RED PANEL
6003	SCREW (4)		
1212	PLASTIC BATTERY COVER		
72	BATTERY CONTACT		