

# SERPAC 123R (3D exploded)

Electronic Enclosures

-Click on image to show toolbar. Use  to Play/Pause Animation.  
-Left click and drag on image to move 3D model.

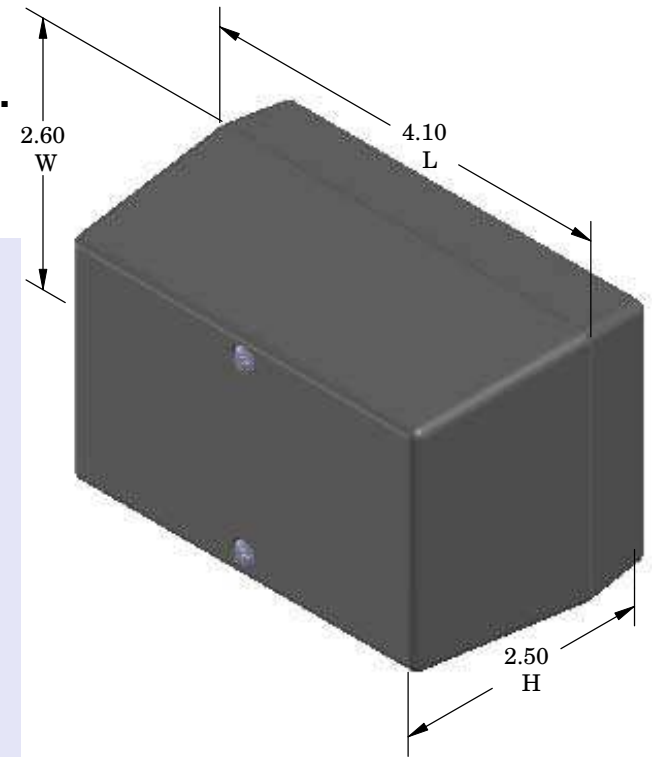
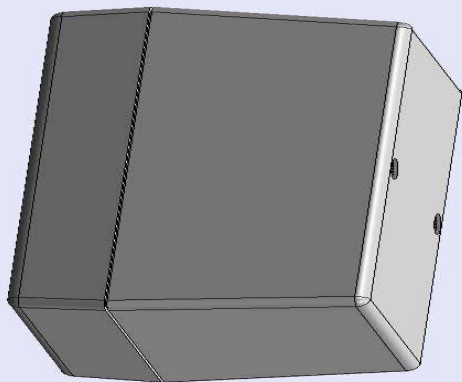

Waterproofing gasket  
PS12 optional  
see note #2

Threaded inserts only  
have to be assembled  
the first time.

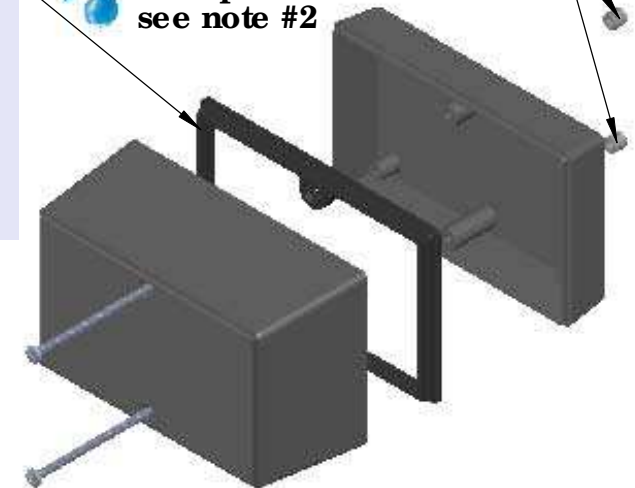

ALL DIMENSIONS ARE ±.010" 7/29/10 (1 of 2)  
2009 Wright Ave. La Verne, CA 91750  
Ph. (626) 331-0517 Ex. (626) 331-8584 serpac.com

- Zoom in & out with center wheel.
- Pause at any moment to view and or print views.
- Change the views to ortho and section views if needed from the Views pull down menu.
- Explore options included in the tool bar like: Views, Transparency of model, Lighting type, etc.

| PART NO. | DESCRIPTION (Included) | ACCESSORIES (Optional) |                |
|----------|------------------------|------------------------|----------------|
| 2-3R     | TOP                    | PART NO.               | DESCRIPTION    |
| 12       | BOTTOM                 | PS12                   | Perimeter Seal |
| 6019     | 4-40 SCREW (2)         |                        |                |
| 6102     | THREADED INSERTS (2)   |                        |                |

Notes: Enclosure weight .21 lbs / 97 gm  
 1) Enclosure meets or exceeds IP40 and NEMA 1  
 2) When used with PS12 the enclosure meets or exceeds IP 67 and NEMA 4X, 12 and 13 MIL-SID-810G 506.5  
 3) Circuit Board drawings can be downloaded at:  
[http://www.serpac.com/Accessories/CircuitBoard/drawings/CB\\_12X.pdf](http://www.serpac.com/Accessories/CircuitBoard/drawings/CB_12X.pdf)  
 4) All components are RoHS Compliant.

# SERPAC 123R (user print)

Electronic Enclosures

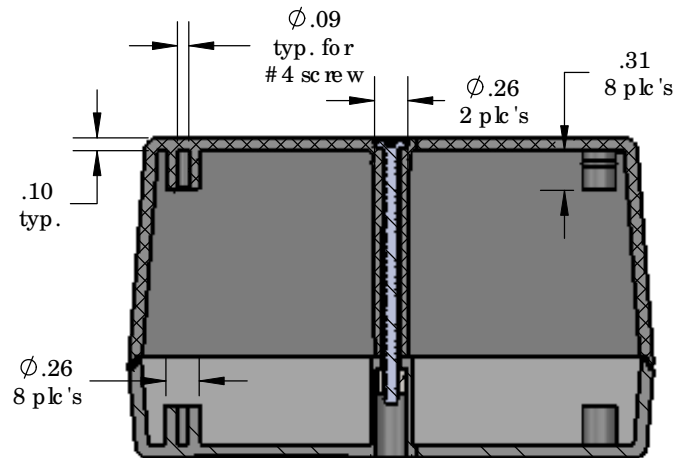
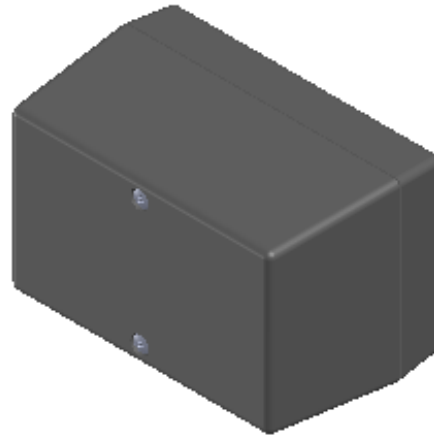
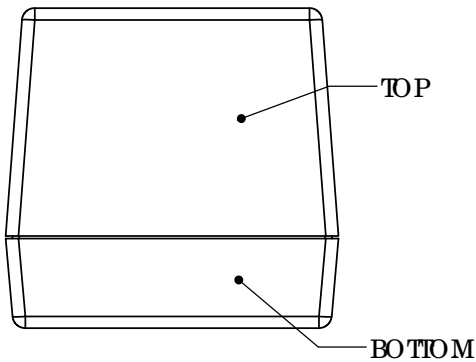
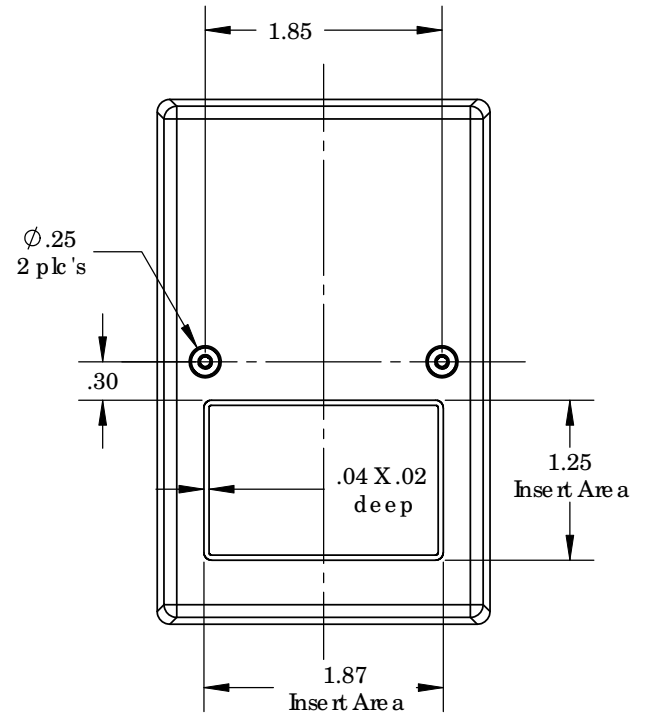
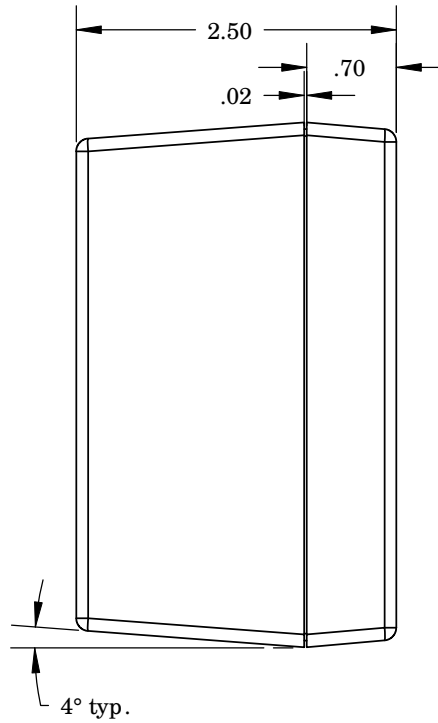
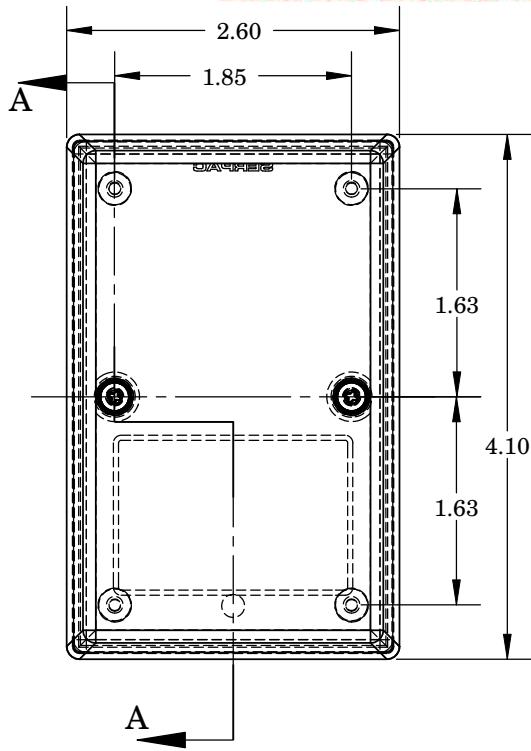

| PART NO. | DESCRIPTION (Included) | ACCESSORIES (Optional) |                |
|----------|------------------------|------------------------|----------------|
| 2-3R     | TOP                    | PART NO.               | DESCRIPTION    |
| 12       | BOTTOM                 | PS12                   | Perimeter Seal |
| 6019     | 4-40 SCREW (2)         |                        |                |
| 6102     | THREADED INSERTS (2)   |                        |                |

Notes: Enclosure weight .21 lbs / 97 gm  
 1) Enclosure meets or exceeds IP40 and NEMA 1  
 2) When used with PS12 the enclosure meets or exceeds IP 67 and NEMA 4X, 12 and 13 MIL-STD-810G 506.5  
 3) Circuit Board drawings can be downloaded at:  
[http://www.serpac.com/Accessories/CircuitBoard/drawings/CB\\_12X.pdf](http://www.serpac.com/Accessories/CircuitBoard/drawings/CB_12X.pdf)  
 4) All components are RoHS Compliant.

ALL DIMENSIONS ARE ± .010" 7/29/10 (2 of 2)  
 2009 Wright Ave. La Verne, CA 91750  
 Ph. (626) 331-0517 Ex. (626) 331-8584 www.serpac.com