

# SERPAC 221R (3D exploded)

Electronic Enclosures

- Click on image to show toolbar. Use  to Play/Pause Animation.
- Left click and drag on image to move 3D model.

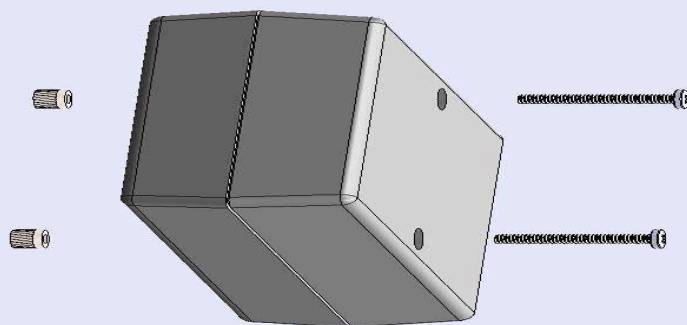

Threaded inserts only have to be assembled the first time.

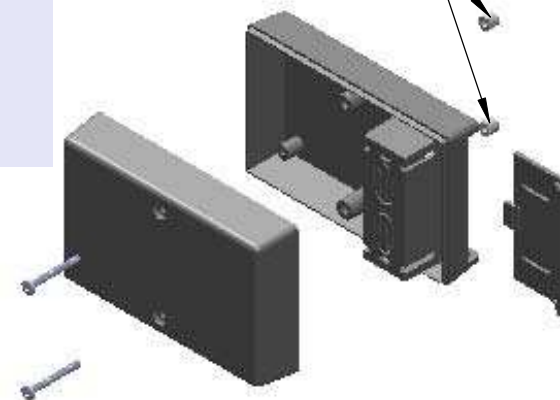

- a) Zoom in & out with center wheel.
- b) Pause at any moment to view and or print views.
- c) Change the views to ortho and section views if needed from the Views pull down menu.
- d) Explore options included in the tool bar like: Views, Transparency of model, Lighting type, etc.

PART NO.	DESCRIPTION (Included)	ACCESSORIES (Optional)	
		PART NO.	DESCRIPTION
2-1R	TOP		
22	BOTTOM	319	Prototype Grid Circuit board
1025	BATTERY COVER	419	Prototype Clad Circuit board
6017	4-40 SCREW (2)		
6102	THREADED INSERTS (2)		

Notes: Enclosure weight .18 lbs / 81 gm  
 1) Enclosure meets or exceeds IP40 and NEMA 1  
 2) Circuit Board drawings can be downloaded at:  
<http://www.serpac.com/Accessories/CircuitBoard/drawings/319-419.pdf>  
 3) All components are RoHS Compliant.

ALL DIMENSIONS ARE ± .010" 8/03/10 (1 of 2)  
 2009 Wright Ave. La Verne, CA 91750  
 Ph. (626) 331-0517 Ex. (626) 331-8584 [serpac.com](http://serpac.com)

# SERPAC 221R (user print)

Electronic Enclosures

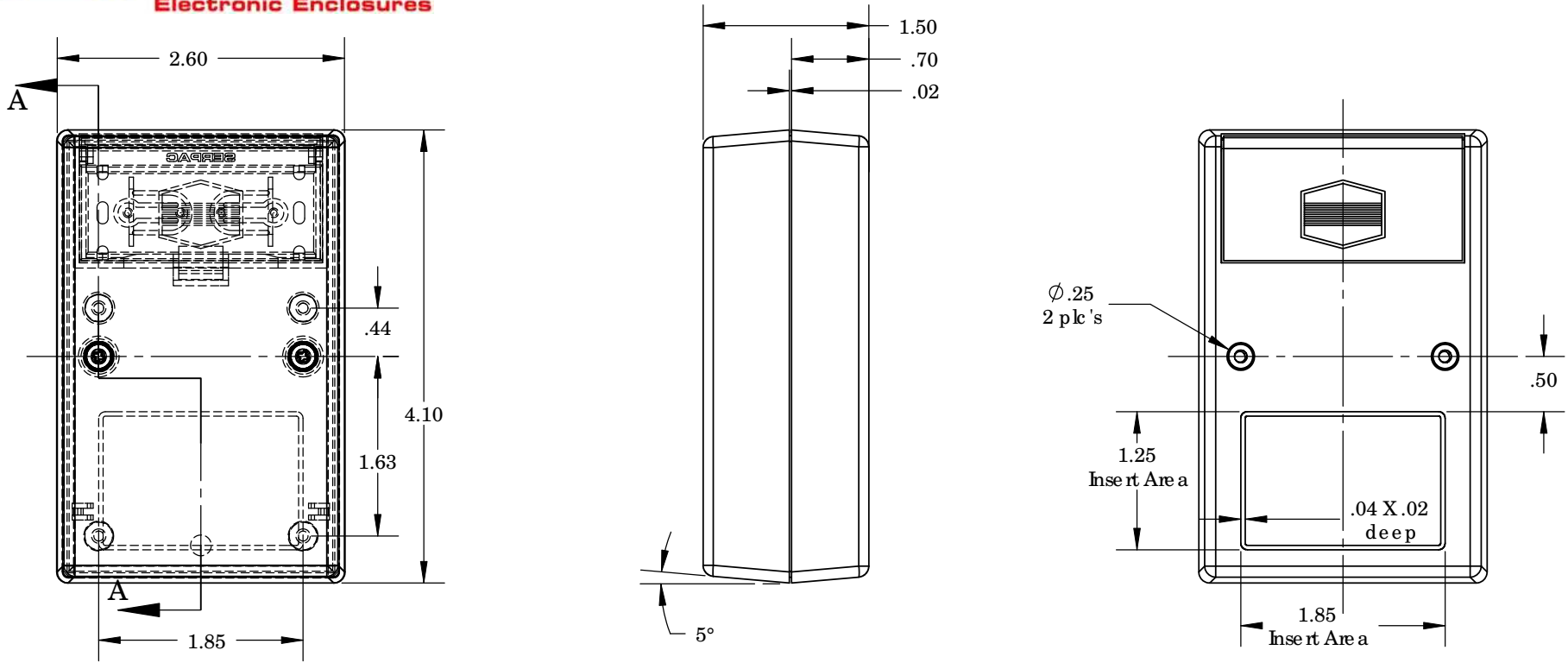

PART NO.	DESCRIPTION (Included)	ACCESSORIES (Optional)	
		PART NO.	DESCRIPTION
2-1R	TOP	319	Prototype Grid Circuit board
22	BOTTOM	419	Prototype Clad Circuit board
6017	4-40 SCREW (2)		
6102	THREADED INSERTS (2)		

Notes: Enclosure weight .18 lbs / 81 gm  
 1) Enclosure meets or exceeds IP40 and NEMA 1  
 2) Circuit Board drawings can be downloaded at:  
<http://www.serpac.com/Accessories/CircuitBoard/drawings/319-419.pdf>  
 3) All components are RoHS Compliant.

SECTION A-A  
 SCALE 1 : 1.5

ALL DIMENSIONS ARE  $\pm .010"$  8/03/10 (2 of 2)  
 2009 Wright Ave. La Verne, CA 91750  
 Ph. (626) 331-0517 Ex. (626) 331-8584 [www.serpac.com](http://www.serpac.com)