

# SERPAC 111 (exploded isometric)

Electronic Enclosures

- Click on image to show toolbar. Use ▶ || to Play/Pause Animation.
- Left click and drag on image to move 3D model.

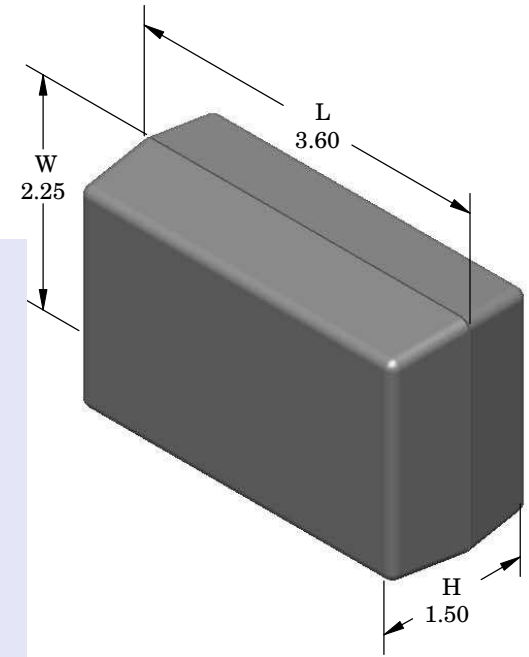
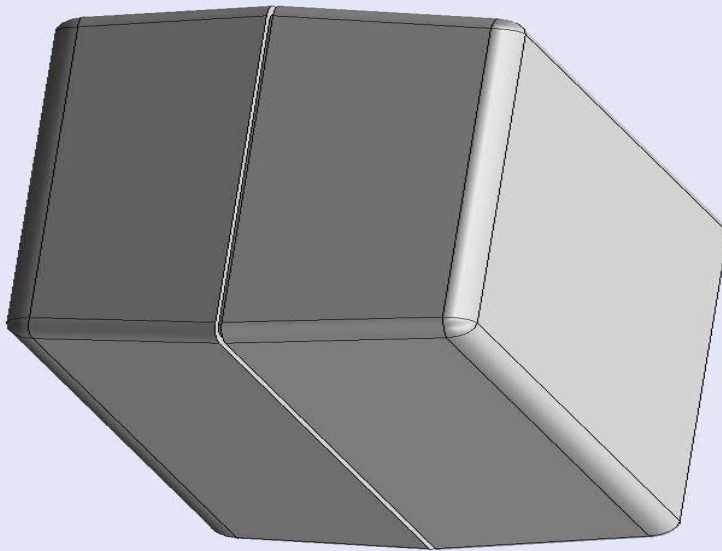

Waterproofing gasket  
PS11 optional  
see note #2

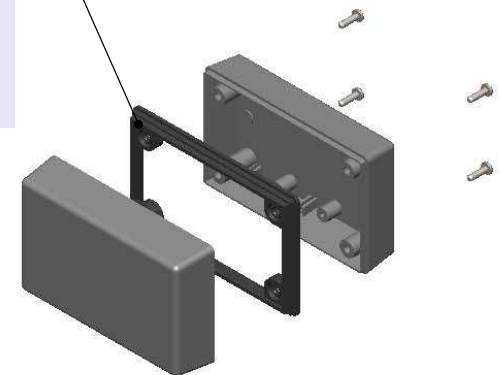

- a) Zoom in & out with center wheel.
- b) Pause at any moment to view and or print views.
- c) Change the views to ortho and section views if needed from the Views pull down menu.
- d) Explore options included in the tool bar like: Views, Transparency of model, Lighting type, etc.

PART NO.	DESCRIPTION (Included)	ACCESSORIES (Optional)	
1-1	TOP	PART NO.	DESCRIPTION
11	BOTTOM	50	Non-skid Feet
6005	#4X3/8" Self tapping (4)	PS11	Perimeter Seal
		310	Prototype grid board
		410	Prototype clad board

- Notes: Enclosure weight .13 lbs/ 58 gm
- 1) Enclosure meets or exceeds IP40 and NEMA 1
  - 2) When used with PS11 the enclosure meets or exceeds IP 67 and NEMA 4X, 12 and 13 MIL-SID-810G 506.5
  - 3) Circuit Board drawings can be downloaded at:  
<http://www.serpac.com/Accessories/CircuitBoard/drawings/310-410.pdf>
  - 4) All components are RoHS compliant.

ALL DIMENSIONS ARE ± .010" 3/18/10 (1 of 2)  
619 Commercial Ave. Covina, CA 91723  
Ph. (626) 331-0517 Ex. (626) 331-8584 [serpac.com](http://serpac.com)

# SERPAC 111 (user print)

Electronic Enclosures

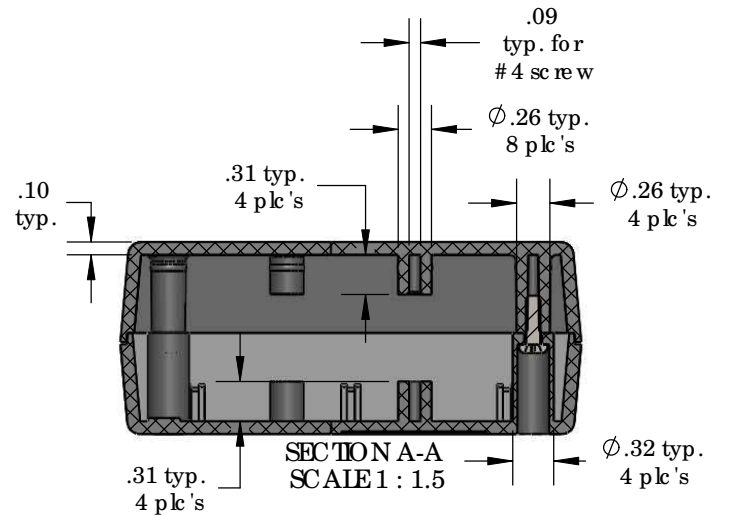
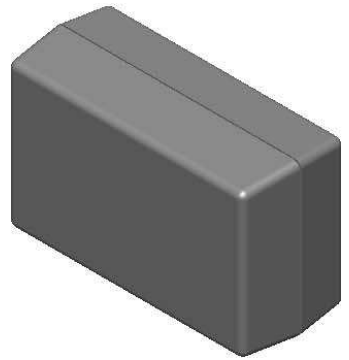
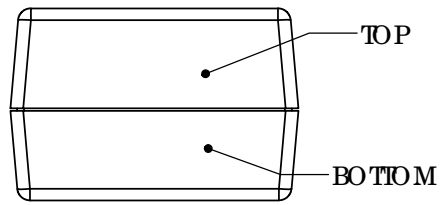
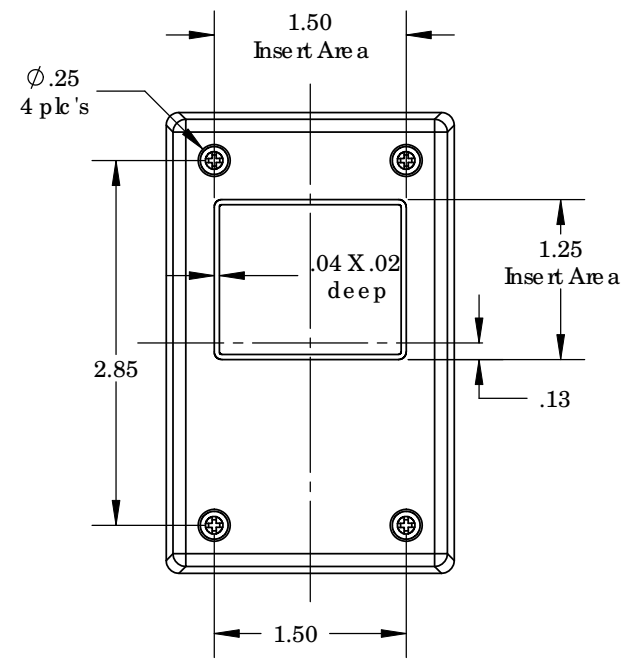
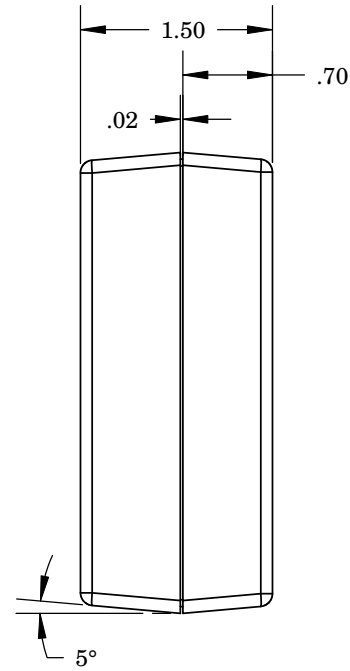
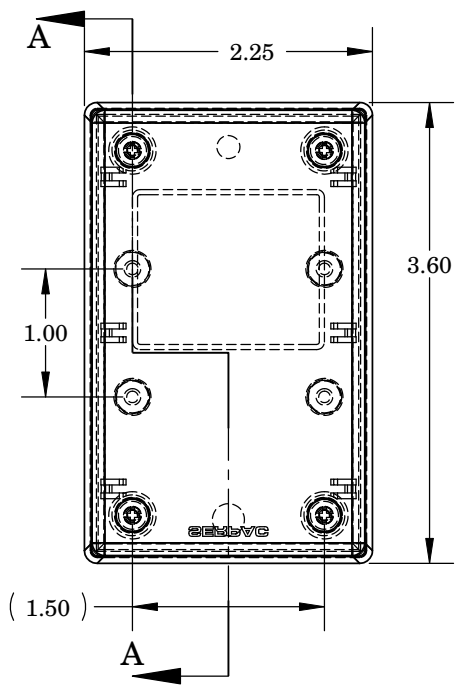

PART NO.	DESCRIPTION (Included)	ACCESSORIES (Optional)	
1-1	TOP	PART NO.	DESCRIPTION
11	BOTTOM	50	Non-skid Feet
6005	#4X3/8" self tapping (4)	PS11	Perimeter Seal
		310	Prototype grid board
		410	Prototype clad board

Notes: Enclosure weight .13 lbs / 58 gm  
 1) Enclosure meets or exceeds IP40 and NEMA 1  
 2) When used with PS11 the enclosure meets or exceeds IP 67 and NEMA 4X, 12 and 13 MIL-STD-810G 506.5  
 3) Circuit Board drawings can be downloaded at:  
<http://www.serpac.com/Accessories/CircuitBoard/drawings/310-410.pdf>  
 4) All components are RoHS Compliant.

ALL DIMENSIONS ARE ± .010" 3/18/10 (2 of 2)  
 619 Commercial Ave. Covina, CA 91723  
 Ph. (626) 331-0517 Ex. (626) 331-8584 www.serpac.com