

NOTES:

- 1) Serpac Provides the following components:
Top, Bottom, Button Membrane, 9mm keyring and (2) #2 Screws.
All components are shipped unassembled.
- 2) The switches characteristics recommended for this enclosure are:
- 4.3 mm in height from mounting surface to top of push plate.
- Operating force recommended is 1.6 N or more.
- 3) For battery contacts use:
- for Coin battery Keystone 3003 positive and 2990 negative

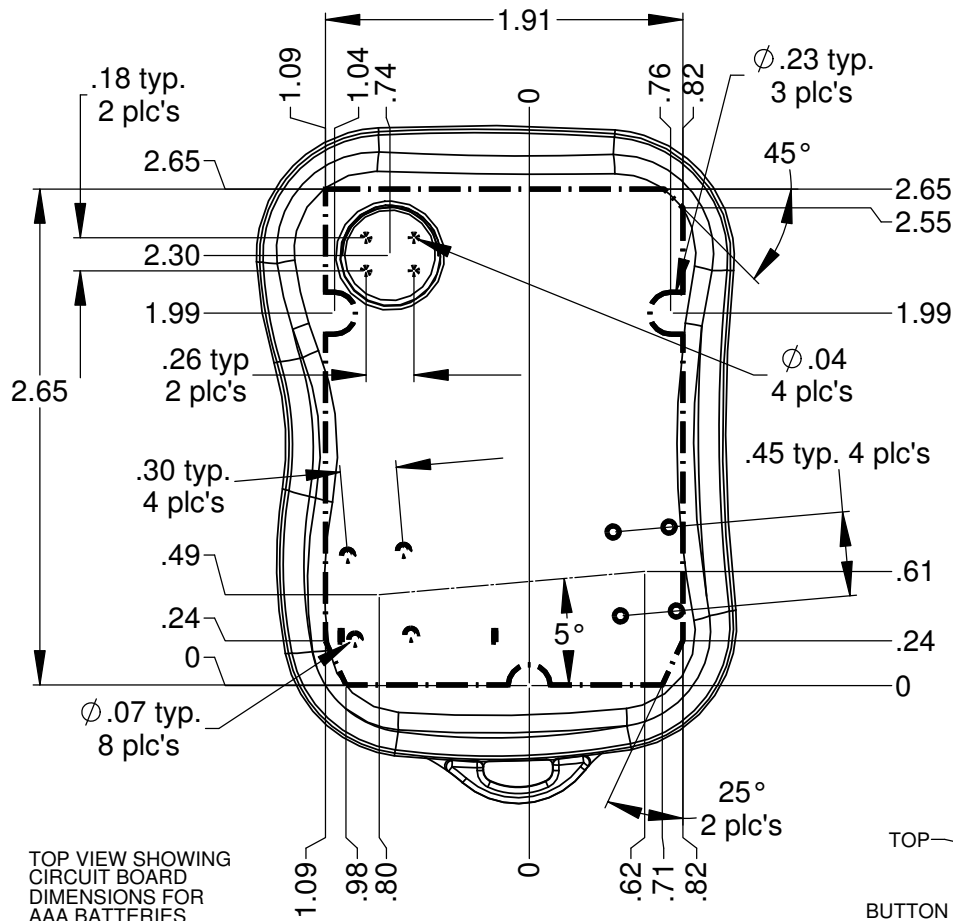

TOP VIEW SHOWING
CIRCUIT BOARD
DIMENSIONS FOR
AAA BATTERIES

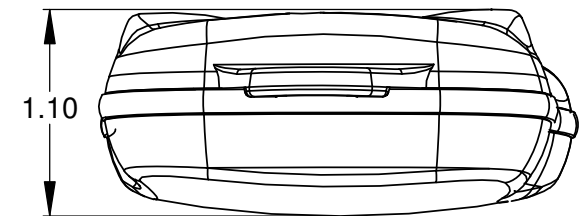
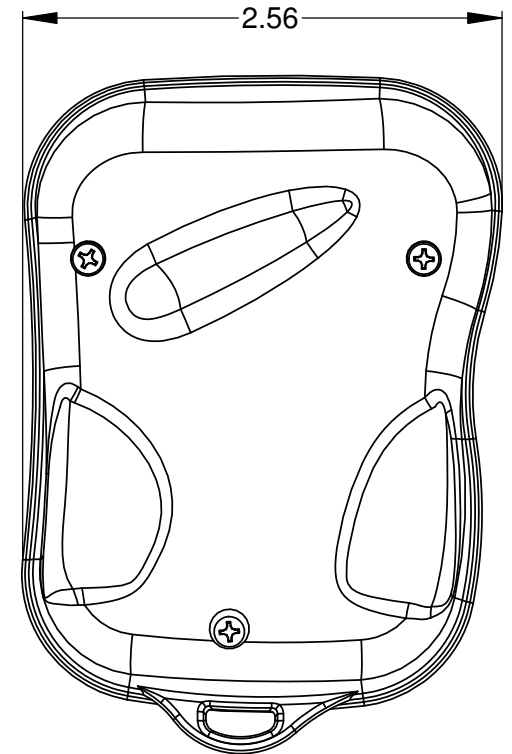
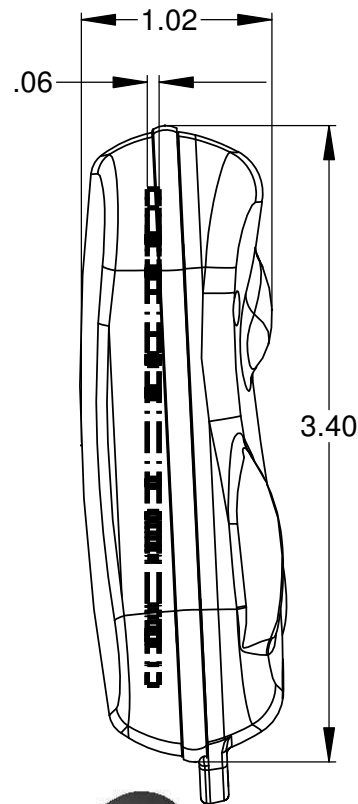

NOTES:

- 1) Serpac Provides the following components:
Top, Bottom, Button Membrane, 9mm keyring and (2) #2 Screws.
All components are shipped unassembled.
- 2) The switches characteristics recommended for this enclosure are:
- 4.3 mm in height from mounting surface to top of push plate.
- Operating force recommended is 1.6 N or more.
- 3) For battery contacts use:
- for (2) AAA Batteries use Keystone 82 (2 per battery)

