

# SERPAC CH4

Electronic Enclosures

**NOTES:**

1) When machine or I-plates modifications are required, use the center of the enclosure to dimension.

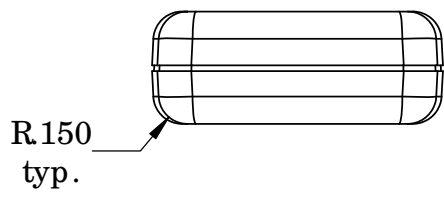
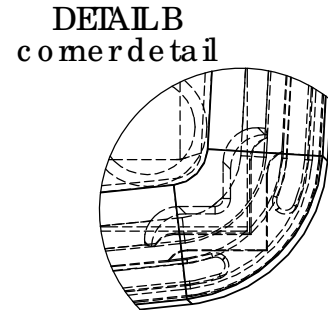
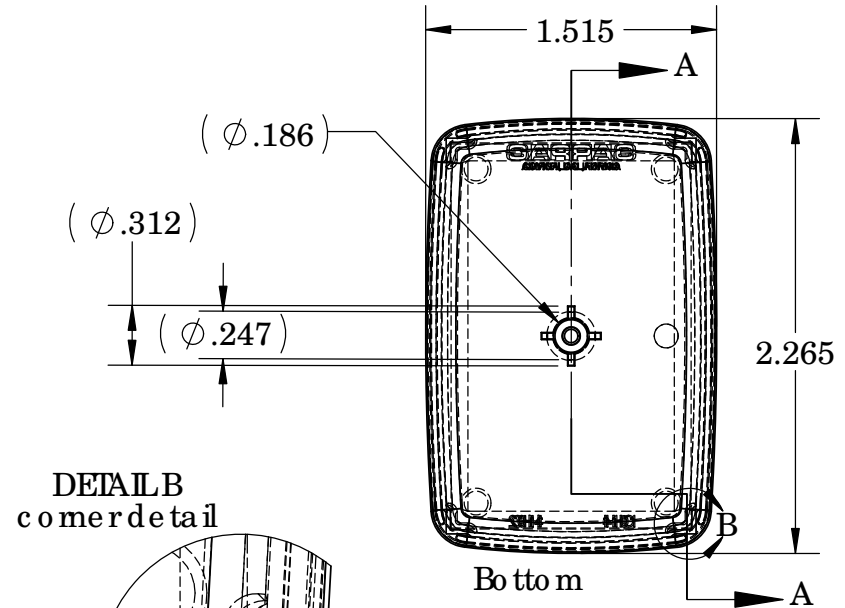
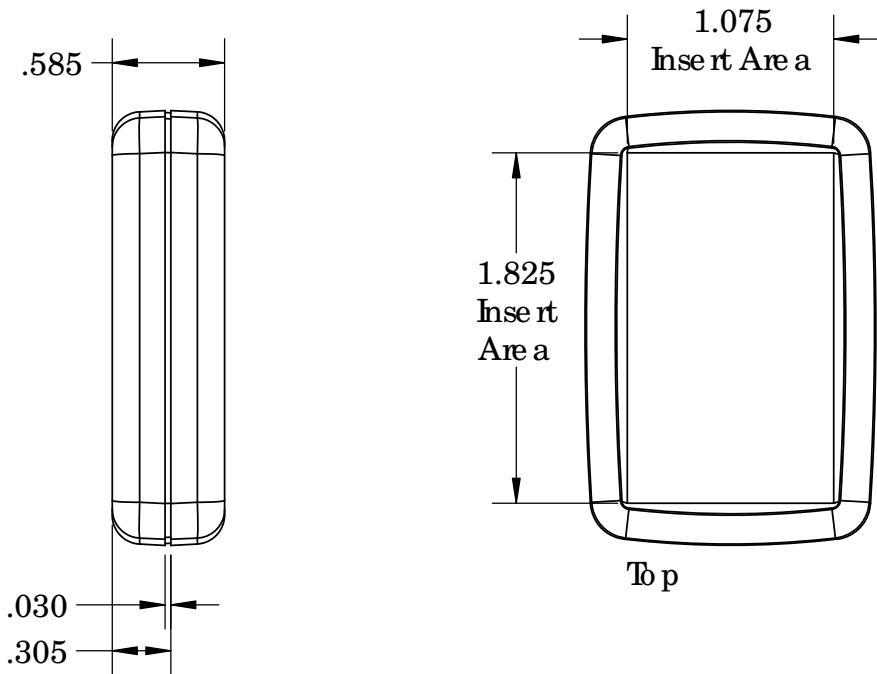

Enclosure can hold either a 0.032" PCB or a 0.063 PCB  
 PCB dimensions are: (PCB drawings on page 2)  
 0.032" [.8mm] PCB 2.04" X 1.28" (0.20" center hole)  
 0.063" [1.6mm] PCB 2.00" X 1.24" (0.26" center hole)

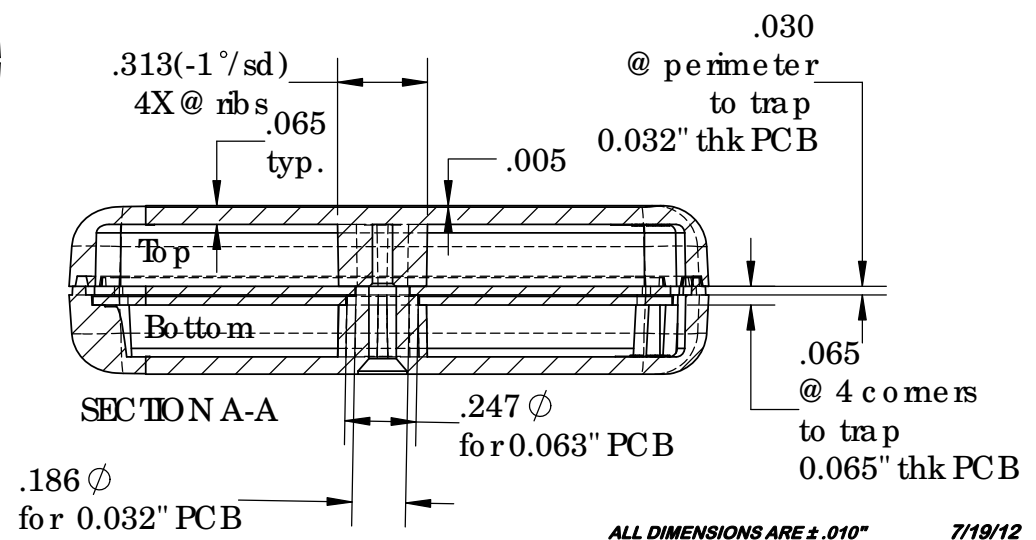

PART NO.	DESCRIPTION	ACCESSORIES	
1101	CH8 TOP	PART NO.	DESCRIPTION
1102	CH8 BOTTOM	55	KEY HOLDER
6003	SCREW 2x1/2" PHILFLAT H/L (1)		

# SERPAC Electronic Enclosures

## CIRCUIT BOARD CH4

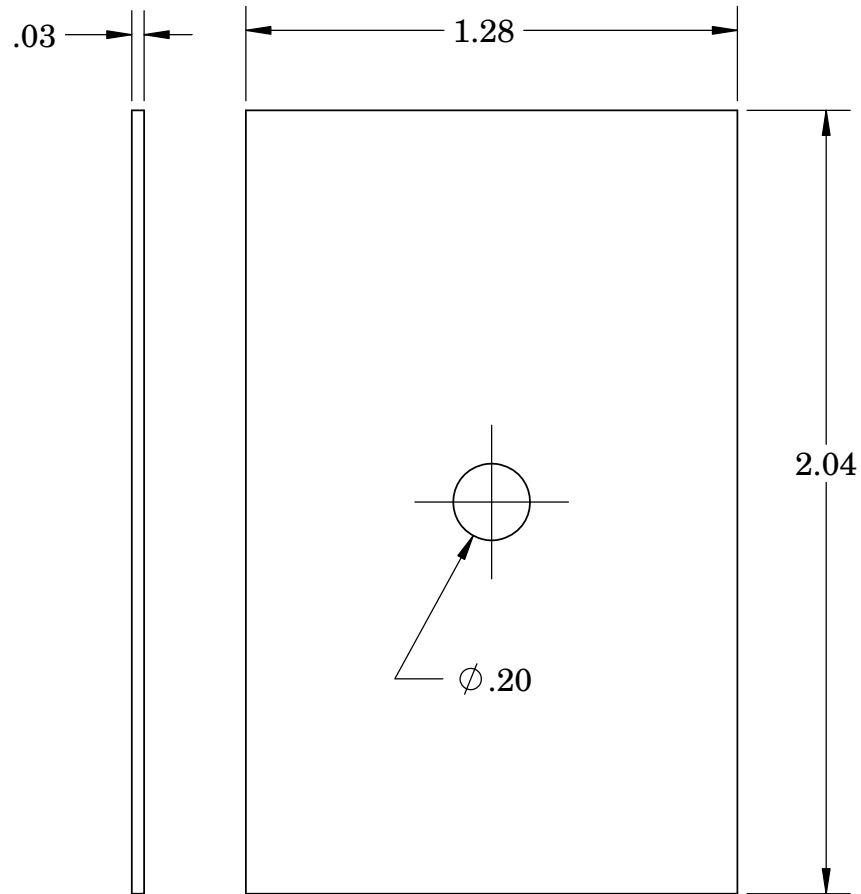

**.032 board**

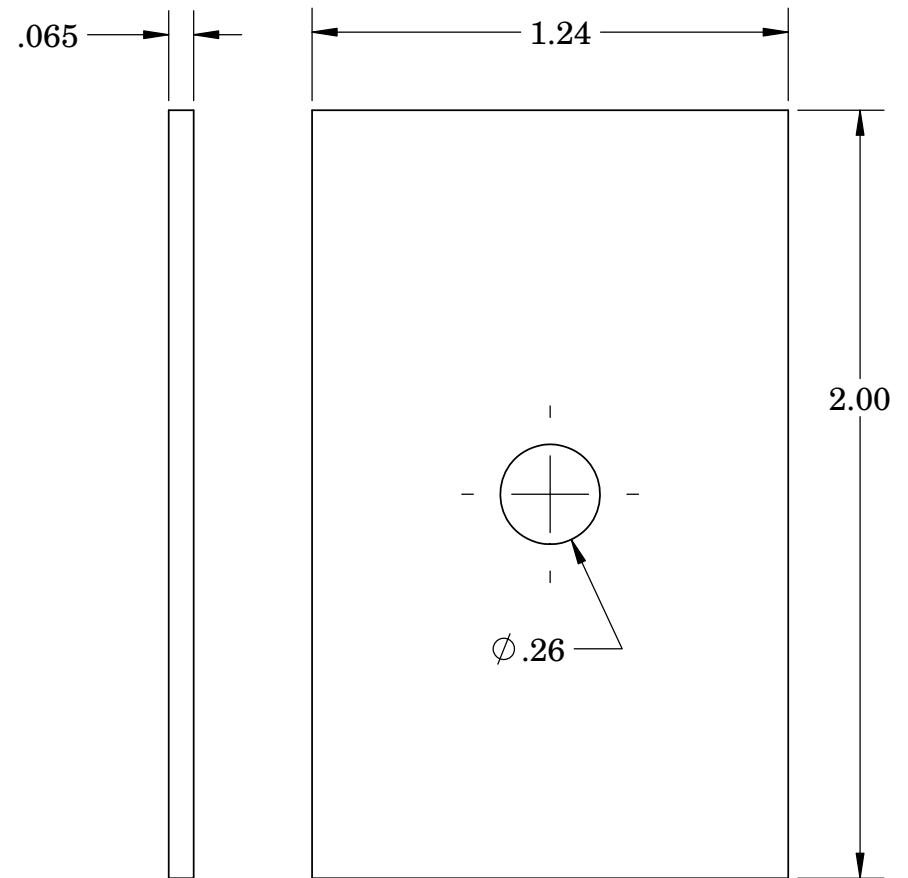

**.065 board**

**NOTES:**  
These are suggested dimensions.  
Plastic parts have a  $\pm 0.010$ " manufacturing tolerance.