

DO NOT SCALE FROM THIS PRINT

"A" RANGE	BODY STYLE		FIG.
	UPPER	LOWER	
.095 - .129 [2.41 - 3.28]	FTM-50-D	FTM-50-D	2
.130 - .245 [3.30 - 6.22]	FTMH-XX-D	MW-XX-D	1

SEE NOTES 5 & 6

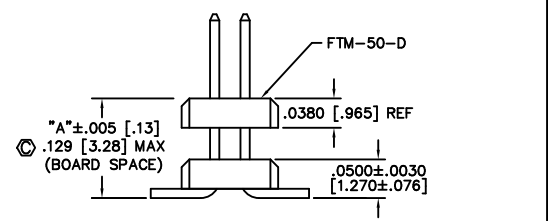
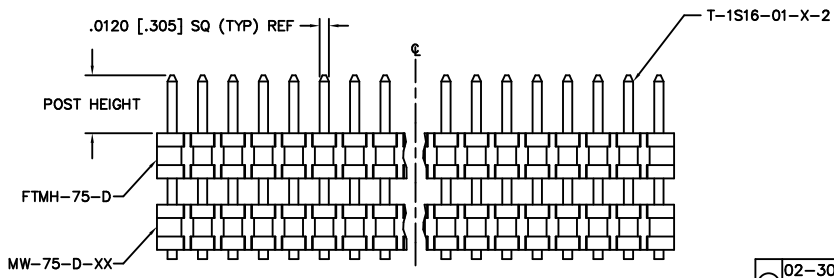
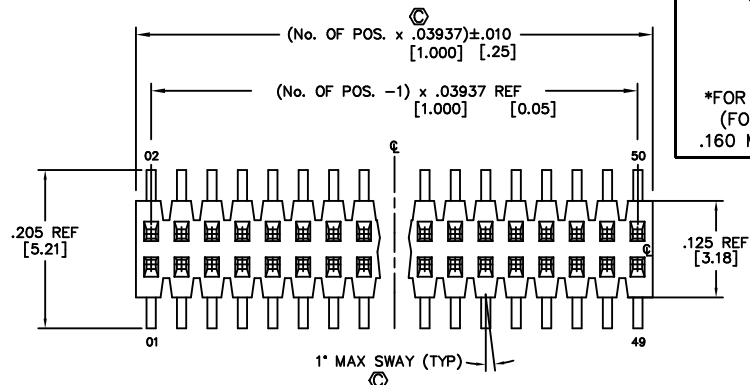
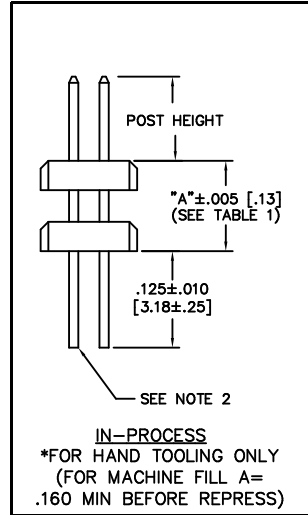
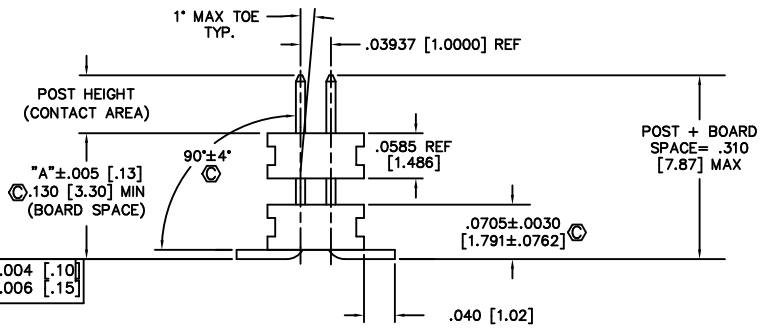

FIG. 2 (DIFFERENT AS SHOWN, OTHERWISE SAME AS FIGURE 1)

- MW-XX-03-X-D-XXX-XXX-XX
- NO. OF POSITIONS: -02 THRU -50 (PER ROW)
 - LEAD STYLE: USE T-1S16-01-X-2 (SEE NOTE 7)
 - PLATING:
 - F: 3µ" SELECTIVE GOLD IN CONTACT AREA, MATTE TIN ON TAIL (USE T-1S16-01-F-2)
 - L: 10µ" SELECTIVE GOLD IN CONTACT AREA, MATTE TIN ON TAIL (USE T-1S16-01-L-2)
 - G: 10µ" GOLD IN CONTACT AREA, 3µ" GOLD ON TAIL (USE T-1S16-01-G-2)
 - H: 30µ" GOLD IN CONTACT AREA, 3µ" GOLD ON TAIL (USE T-1S16-01-H-2)
 - ROW OPTION: -D: DOUBLE (SEE TABLE 1 FOR BODY)
 - BOARD SPACE OPTION: *A: .245 [6.22] MAX w/ .065 [1.65] POST, .095 [2.41] MIN.
 - POST HEIGHT: .085 [1.65] MIN (POST + BOARD SPACE= .310 [7.87] MAX)
- OPTION
- P: PICK & PLACE PAD (SEE SHT 2, FIG 3, USE PPP-30) (7 POS PER ROW MIN) (USE PPP-30-NIT FOR -TR ONLY)
 - ES: END SHROUDS (9 POS PER ROW MIN) (SEE SHT 2, FIG 4) (MAX POST: .075 [1.91]) (SEE NOTE 8)
 - EP: GUIDE POST (9 POS PER ROW MIN) (SEE SHT 2, FIG 5) (MAX POST: .075 [1.91]) (SEE NOTE 8)
 - A: ALIGNMENT PINS (MOLDED OR STAKED, SAMTEC'S DISCRETION ON WHICH)(SEE FIGS 6 & 7, SHT 3) (STAKED: 7 POS MIN, 60 POS MAX) (MOLDED: 5 POS MIN, 75 POS MAX) (SEE NOTE 8)
 - TR: TAPE & REEL (ALL POSITIONS) (MAX HEIGHT: .6875)

- NOTES:
- PARTS MAY BE CUT TO POSITION; .010 MAX CUT FLASH.
 - SHEAR TAILS TO DIMENSION SHOWN; .003 MAX BURR. (FOR HAND TOOLING ONLY)
 - C REPRESENTS A CRITICAL DIMENSION
 - LAYER PACKAGE POSITIONS 05 THROUGH 50 IN TUBES; AVAILABLE ONLY WITH BOARD SPACE: .130 TO .245. BOARD SPACE .095-.129 WILL HAVE BLACK FTM BODY.
 - HAND ASSEMBLED PARTS TO BE 2 BLACK BODIES AND MACHINE ASSEMBLED TO BE TOP-BLACK BOTTOM; NATURAL. BOARD SPACE: .130-.245. BOARD SPACE .095-.129 WILL HAVE BLACK FTM BODY.
 - FOR HAND FILL, USE FTMH-XX-D FOR LOWER BODY.
 - FOR MACHINE FILLED, USE T-1S16-03-X-2.
 - AVAILABLE ONLY WITH BOARD SPACE: .130 TO .245.
 - .75 POSITION AVAILABLE FOR SAMTEC INVENTORY ONLY.
 - FOR ADDED MECHANICAL STABILITY, SAMTEC RECOMMENDS MECHANICAL BOARD SPACERS BE USED IN APPLICATIONS WITH GOLD OR SELECTIVE GOLD PLATED CONNECTORS. CONTACT IPG@SAMTEC.COM FOR MORE INFORMATION.



02-30 POS. = .004 [.10]
31-50 POS. = .006 [.15]

FIG. 1

PROPRIETARY NOTE
THIS DOCUMENT CONTAINS INFORMATION OF A PROPRIETARY NATURE AND IS THE PROPERTY OF SAMTEC. IT IS TO BE USED ONLY FOR THE PURPOSES SPECIFIED AND IS NOT TO BE REPRODUCED OR TRANSMITTED IN ANY FORM OR BY ANY MEANS, ELECTRONIC OR MECHANICAL, INCLUDING PHOTOCOPYING, RECORDING, OR BY ANY INFORMATION STORAGE AND RETRIEVAL SYSTEM, WITHOUT THE WRITTEN PERMISSION OF SAMTEC.

MATERIALS:
FTM-50-D & FTMH-75-D
LIQUID CRYSTAL POLYMER
COLOR: BLACK
MW-75-D-XX
LIQUID CRYSTAL POLYMER
COLOR: NATURAL
TERMINAL:
PHOS BRONZE
MAX FLASH ALLOWED:
.002 [.05]
MAX GATE VESTIGE ALLOWED:
.002 [.05]

EXP/PROD/ASSEMBLY/mm MW-ASB

samtec

520 PARK EAST BLVD. NEW ALBANY, INDIANA 47150
PHONE (812) 944-6733 P.O. BOX 1147
CODE 55322

MADE BY: BRATCHER 4-3-95

MW-XX-03-X-D-XXX-XXX-XX SHEET 1 OF 3