

DO NOT SCALE FROM THIS PRINT

NOTES:

1. Ⓢ REPRESENTS A CRITICAL DIMENSION.
2. TUBE POSITIONS -05 THRU -36 ONLY; POSITIONS -02 THRU -04 TO BE LAYER PACKAGED.
3. MAXIMUM CUT FLASH: .020 [0.51] CUT FLASH TO BE IN A NON-CRITICAL AREA LOCATED BETWEEN BODIES.
4. FOR ADDED MECHANICAL STABILITY, SAMTEC RECOMMENDS MECHANICAL BOARD SPACERS BE USED IN APPLICATIONS WITH GOLD OR SELECTIVE GOLD PLATED CONNECTORS. CONTACT IPG@SAMTEC.COM FOR MORE INFORMATION.

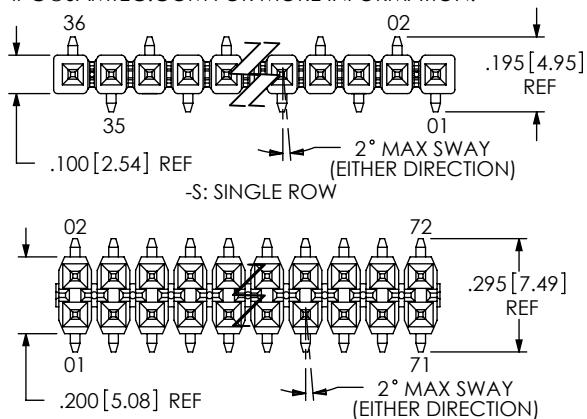

FIG 1
HW-XX-10-XX-X-675-SM SHOWN

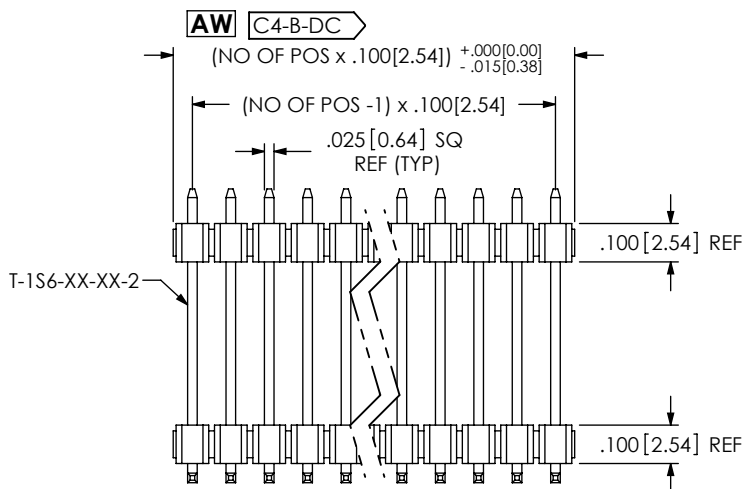

TABLE 1

LEAD STYLE	TERMINAL	"H"	"A" WHEN "B" IS .090 [2.29]	"C"	IN-PROCESS OAL REF
-08	T-1S6-08-XX-2	.465 [11.81]	.375 [9.53]	.315 [8.00]	.530 [13.46]
-09	T-1S6-09-XX-2	.665 [16.89]	.575 [14.61]	.515 [13.08]	.730 [18.54]
-10	T-1S6-10-XX-2	.765 [19.43]	.675 [17.15]	.615 [15.62]	.830 [21.08]
-11	T-1S6-11-XX-2	.865 [21.97]	.775 [19.69]	.715 [18.16]	.930 [23.62]
-12	T-1S6-12-XX-2	.965 [24.51]	.875 [22.23]	.815 [20.70]	1.030 [26.16]
-15	T-1S6-15-XX-2	.565 [14.35]	.475 [12.07]	.415 [10.54]	.630 [16.00]
-16	T-1S6-16-XX-2	.380 [9.65]	.290 [7.37]	.230 [5.84]	.445 [11.30]
-17	T-1S6-17-XX-2	.415 [10.54]	.325 [8.26]	.265 [6.73]	.480 [12.19]
-20	T-1S6-20-XX-2	1.065 [27.05]	.975 [24.77]	.915 [23.24]	1.130 [28.70]

HW-XX-XX-XX-X-XXXX-SM-X-XXX

No OF POSITIONS
-02 THRU -36
LEAD STYLE
(SEE TABLE 1)

OPTION #2
POLARIZED POSITION
SPECIFY OMITTED PIN

- OPTION #1
-LC: LOCKING CLIP (SEE FIG 2, SHT 2)
(-D: USE RTSM-50-DVU, USE LC-05-TM)
(-S: USE TSM-50-SV BODY, USE LC-08-TM-02)
-A: ALIGNMENT PIN (SEE FIG 3, SHT 2)
(-S: 3 POSITION USE TSM-03-SV-A, MUST BE MOLDED TO POSITION)
(4-50 POSITIONS USE TSM-XX-SV-XX, 2 POSITIONS TO USE TSM-48-SV-04)
(-D: FOR MOLDED TO POSITION, USE RTSM-50-DVU-XX BODY, AVAILABLE ON POS -02 THRU -36)
(-D: FOR STAKED, USE RTSM-50-DVU BODY, 3 POS MIN)
-TR: TAPE & REEL
(5 THRU 27 POSITIONS ONLY)
(MAX HEIGHT: .6875)
LEAVE BLANK FOR NO HOLD DOWN OPTION
(-D: USE RTSM-50-DVU, CAN BE CUT TO POSITION, SEE FIG 1)
(-S: USE TSM-50-SV, CAN BE CUT TO POSITION, SEE FIG 1)

PLATING SPECIFICATION

- T: MATTE TIN ON CONTACT AND TAIL.
- S: 30μ" SELECTIVE GOLD IN CONTACT AREA, MATTE TIN ON TAIL.
- G: 10μ" SELECTIVE GOLD IN CONTACT AREA, 3μ" SELECTIVE GOLD ON TAIL.
- L: 10μ" SELECTIVE GOLD IN CONTACT AREA, MATTE TIN ON TAIL.
- TL: 250μ" TIN/LEAD ON CONTACT AND TAIL.
- H: 30μ" SELECTIVE GOLD IN CONTACT AREA, 3μ" SELECTIVE GOLD ON TAIL.
- F: 3μ" SELECTIVE GOLD IN CONTACT AREA, MATTE TIN ON TAIL.
- TM: MATTE TIN ON CONTACT AND TAIL.
- SM: 30μ" SELECTIVE GOLD IN CONTACT AREA, MATTE TIN ON TAIL.
- LM: 10μ" SELECTIVE GOLD IN CONTACT AREA, MATTE TIN ON TAIL.
- FM: 3μ" SELECTIVE GOLD IN CONTACT AREA, MATTE TIN ON TAIL.

ROW OPTION

- D: DOUBLE ROW
(USE RTSM-50-DVU FOR BOTTOM INSULATOR)
(USE WRTSM-50-DVU FOR TOP INSULATOR)
- S: SINGLE ROW
(USE TSM-XX-S BODY FOR BOTTOM INSULATOR)
(USE WTSM-50-SV FOR TOP INSULATOR)

SURFACE MOUNT

BOARD SPACE

"A" = -XXX
(SEE FIG 1 & TABLE 1)
MAX = C + .150

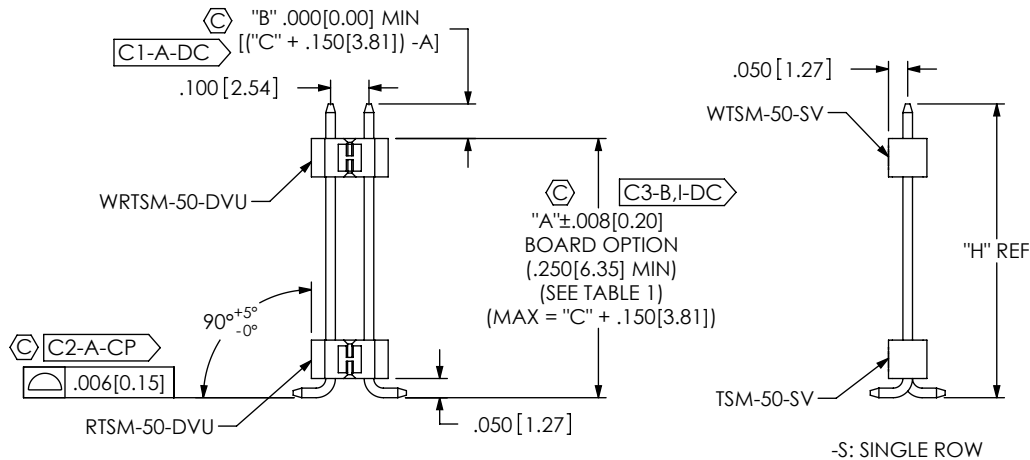

-S: SINGLE ROW

UNLESS OTHERWISE SPECIFIED, DIMENSIONS ARE IN INCHES. TOLERANCES ARE:
DECIMALS ANGLES
.XX: ±.01 [0.3] 2°
.XXX: ±.005 [0.13]
.XXXX: ±.0020 [0.051]

PROPRIETARY NOTE
THIS DOCUMENT CONTAINS INFORMATION CONFIDENTIAL AND PROPRIETARY TO SAMTEC, INC. AND SHALL NOT BE REPRODUCED OR TRANSFERRED TO OTHER DOCUMENTS OR DISCLOSED TO OTHERS OR USED FOR ANY PURPOSE OTHER THAN THAT WHICH IT WAS OBTAINED WITHOUT THE EXPRESSED WRITTEN CONSENT OF SAMTEC, INC.



520 PARK EAST BLVD, NEW ALBANY, IN 47150
PHONE: 812-944-6733 FAX: 812-948-5047
e-Mail: info@SAMTEC.com code 55322

MATERIAL: DO NOT SCALE DRAWING SHEET SCALE: 2:1
INSULATOR: LCP, UL 94 V0, COLOR: BLACK
TERMINAL: PHOS BRONZE

DESCRIPTION:
HW BOARD TO BOARD ASSEMBLY

DWG. NO.
HW-XX-XX-XX-X-XXXX-SM-X-XXX

BY: G PURVIS 03/12/1993 SHEET 1 OF 2

REVISION AW

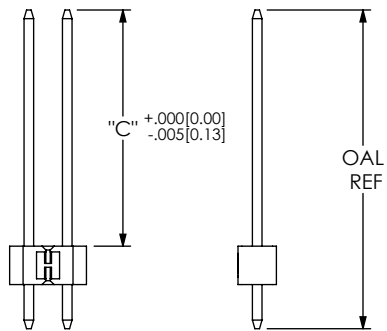

IN-PROCESS

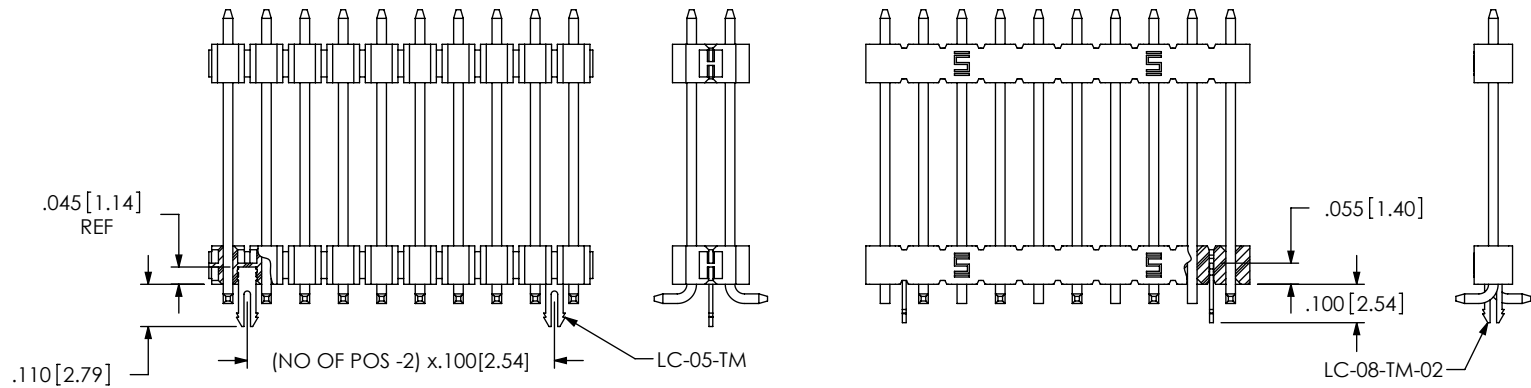

-D: DOUBLE ROW

FIG 2
-LC: LOCKING CLIP
(SAME AS FIG 1, DIFFERENT AS SHOWN)

-S: SINGLE ROW

CRITICAL DIMENSION INSPECTION INSTRUCTION TABLE	
ASSEMBLY OPERATION	IN-PROCESS INSPECTION
FILL	C1
FORM	C2, C3*
MOUNT BODY	C3*
CUT	C4
*WHERE APPLICABLE	

AW

ROW OPTION	PACKAGING TUBE (SEE NOTE 2)	PLUG
-S: SINGLE	PT-1-24-01-47	TP-24
-D: DOUBLE	PT-1-24-02-47	TP-03
-LEAD STYLE -20 DOUBLE	PT-1-24-03-47	TP-03
-LEAD STYLE -20 SINGLE	PT-1-24-08-03	TP-07

FIG 4
PACKAGING VIEW
(TUBE PLUG LOCATED AS SHOWN)

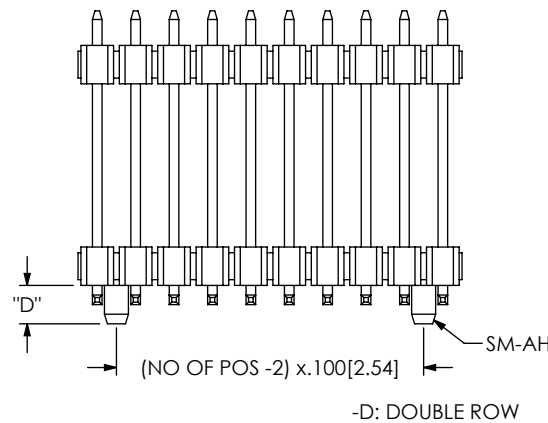
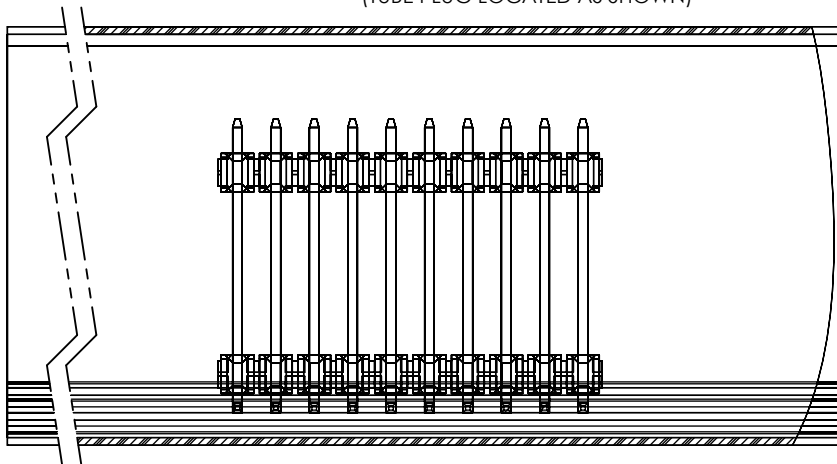

-D: DOUBLE ROW

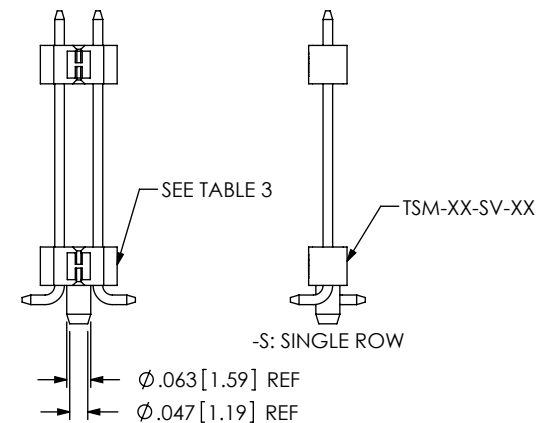

FIG 3
-A: ALIGNMENT PIN
(SAME AS FIG 1, DIFFERENT AS SHOWN)
(2 POS USE 1 PER STRIP, 3-36 POS USE 2 PER STRIP)

	"D"	BODY
MOLDED	.100 [2.54] REF	RTSN-50-DVU-XX TSM-XX-SV-XX
STAKED	.100 [2.54] ± .005 [0.13]	RTSM-50-DVU

PROPRIETARY NOTE
THIS DOCUMENT CONTAINS INFORMATION CONFIDENTIAL AND PROPRIETARY TO SAMTEC, INC. AND SHALL NOT BE REPRODUCED OR TRANSFERRED TO OTHER DOCUMENTS OR DISCLOSED TO OTHERS OR USED FOR ANY PURPOSE OTHER THAN THAT WHICH IT WAS OBTAINED WITHOUT THE EXPRESSED WRITTEN CONSENT OF SAMTEC, INC.

DO NOT SCALE DRAWING

SHEET SCALE: 2:1

samtec

520 PARK EAST BLVD, NEW ALBANY, IN 47150
PHONE: 812-944-6733 FAX: 812-948-5047
e-Mail: info@SAMTEC.com code 55322

DESCRIPTION:
HW BOARD TO BOARD ASSEMBLY

DWG. NO.
HW-XX-XX-XX-X-XXXX-SM-X-XXX

BY: G PURVIS 03/12/1993 SHEET 2 OF 2