

REVISION P

DO NOT SCALE FROM THIS PRINT

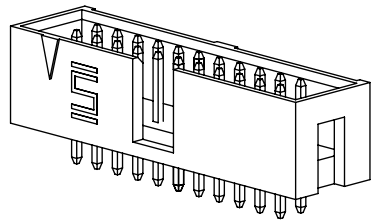

HTST-1XX-XX-XX-D-XX-XX

No OF POSITIONS
 -02 (STRAIGHT ONLY)
 -03 THRU -18, -20, -24, -25, -28, -30, -32 & -36

LEAD STYLE
 SEE TABLE 1 & TABLE 2

POLARIZATION OPTION
 -XX: INDICATES POSITION OMITTED

OPTION
 BLANK: STRAIGHT (STYLES -04 & -05 N/A)
 -RA: RIGHT ANGLE (STYLES -01, -02 & -03 N/A)
 -LL: LOCKING LEAD (STRAIGHT ONLY)
 -LA: -RA OPTION WITH -LL OPTION

ROW SPECIFICATION
 -D: DOUBLE ROW (USE HTST-XX-D)

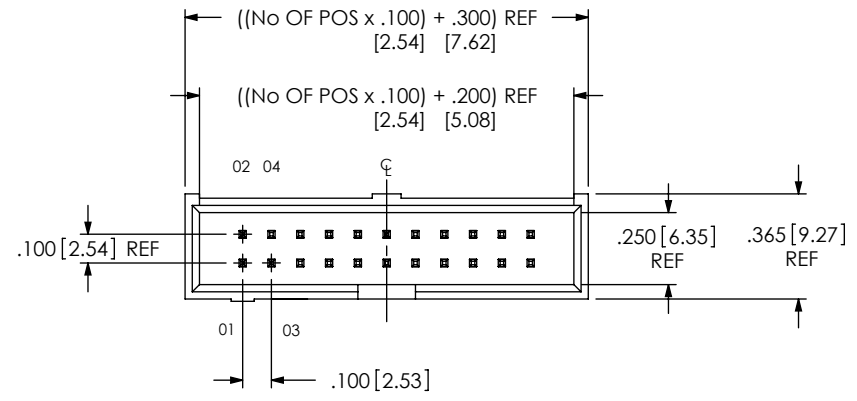

PLATING SPECIFICATION
 -G: GOLD, 10 Au / 50 Ni MIN ON CONTACT, 3 Au / 50 Ni MIN ON TAIL
 -T: MATTE TIN, CONTACT AND TAIL
 -S: SELECTIVE, 30 Au / 50 Ni MIN ON CONTACT, MATTE TIN TAIL
 -L: LIGHT SELECTIVE, 10 Au / 50 Ni MIN ON CONTACT, MATTE TIN TAIL
 -H: HEAVY GOLD, 30 Au / 50 Ni MIN ON CONTACT, 3Au / 50 Ni MIN ON TAIL
 -F: FLASH SELECTIVE, 3 Au / 50 Ni ON CONTACT, MATTE TIN TAIL
 -TM: MATTE TIN CONTACT AND TAIL
 -SM: SELECTIVE, 30 Au / 50 Ni ON CONTACT, MATTE TIN TAIL
 -FM: FLASH SELECTIVE, 3 Au / 50 Ni MIN ON CONTACT, MATTE TIN TAIL
 -LM: LIGHT SELECTIVE, 10 Au / 50 Ni MIN, MATTE TIN TAIL

LEAD STYLE	"A"	TERMINAL
-01	.480[12.19]	T-1S6-17-XX-2
-02	.530[13.46]	T-1S6-08-XX-2
-03	.930[23.62]	T-1S6-11-XX-2

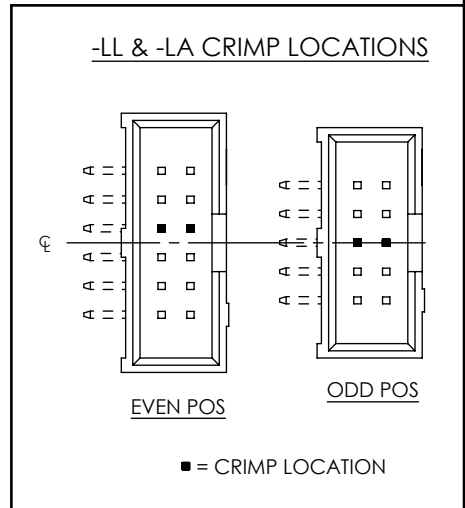
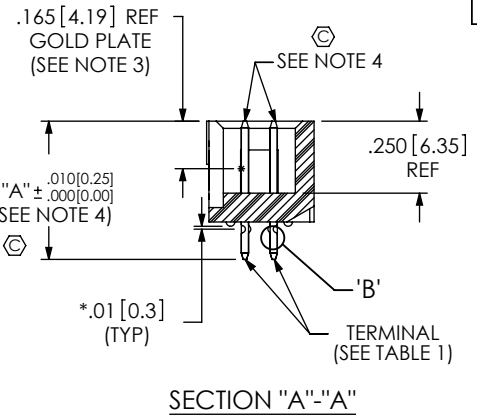
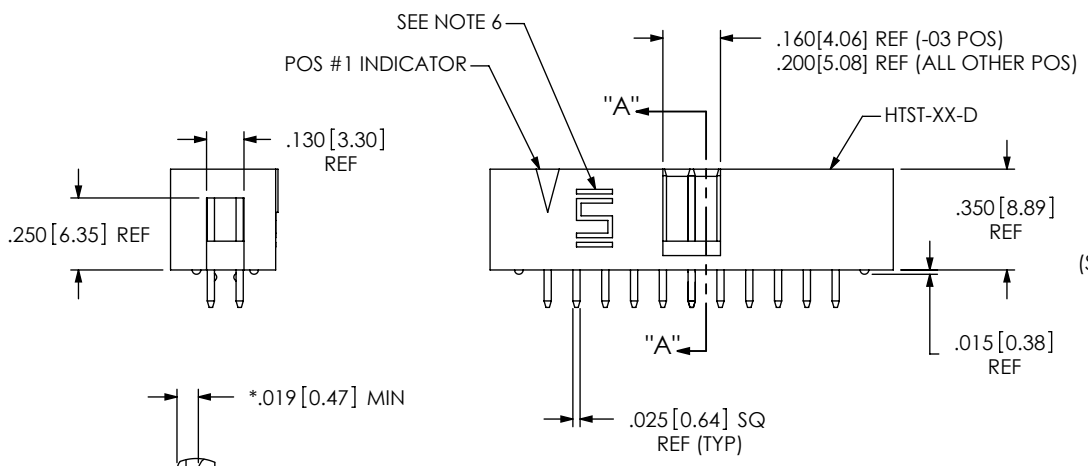

FIG 1
 HTST-111-0T-XX-D-LL SHOWN
 * DIMENSIONS APPLY WHEN USING -LL OPTION ONLY

DETAIL 'B'
 SCALE 6:1

NOTES:

- © REPRESENTS A CRITICAL DIMENSION.
- TERMINAL PUSHOUT FORCE: 3 lbs.
- ASSEMBLE GOLD PLATED END AS SHOWN.
- TERMINALS TO BE FLUSH TO .010[.25] BELOW TOP OF SHROUD.

UNLESS OTHERWISE SPECIFIED, DIMENSIONS ARE IN INCHES. TOLERANCES ARE: DECIMALS ANGLES .XX: ±.01 [.3] 2° .XXX: ±.005 [.13] .XXXX: ±.0020 [.051]	PROPRIETARY NOTE THIS DOCUMENT CONTAINS INFORMATION CONFIDENTIAL AND PROPRIETARY TO SAMTEC, INC. AND SHALL NOT BE REPRODUCED OR TRANSFERRED TO OTHER DOCUMENTS OR DISCLOSED TO OTHERS OR USED FOR ANY PURPOSE OTHER THAN THAT WHICH IT WAS OBTAINED WITHOUT THE EXPRESSED WRITTEN CONSENT OF SAMTEC, INC.		
		520 PARK EAST BLVD, NEW ALBANY, IN 47150 PHONE: 812-944-6733 FAX: 812-948-5047 e-Mail: info@SAMTEC.com code: 53322	
MATERIAL: DO NOT SCALE DRAWING SHEET SCALE: 1.5:1		DESCRIPTION: HIGH TEMP TOP SHROUD TERMINAL STRIP	
INSULATOR: LCP, UL 94 VO COLOR: NATURAL		DWG. NO. HTST-1XX-XX-XX-D-XX-XX	
TERMINAL: PHOS BRONZE		BY: BRATCHER 01/16/04 SHEET 1 OF 2	

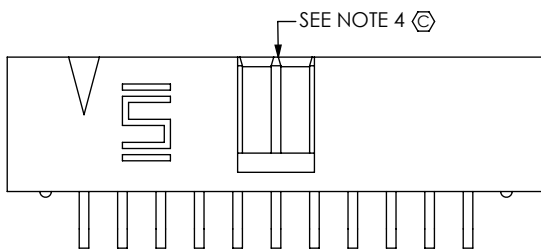
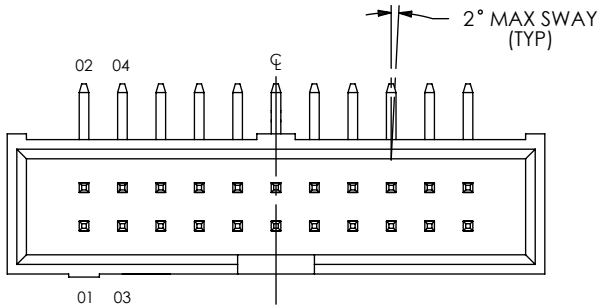
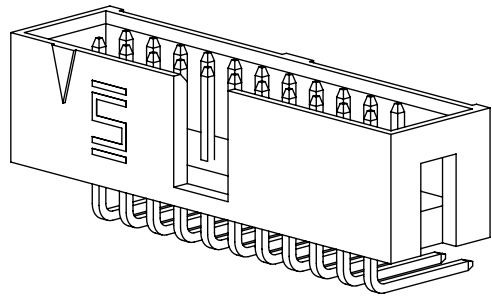

.035±.010 [0.89±0.25]
(TYP)

Ⓢ*.0080 [0.203]
(TYP)

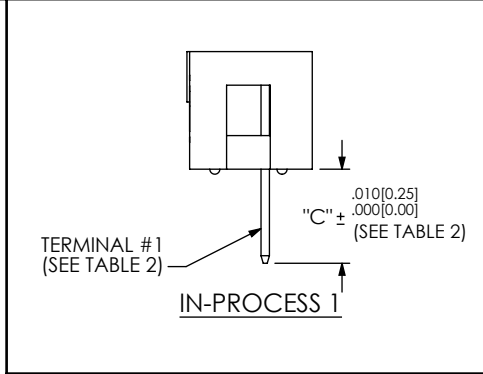
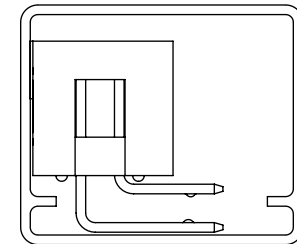
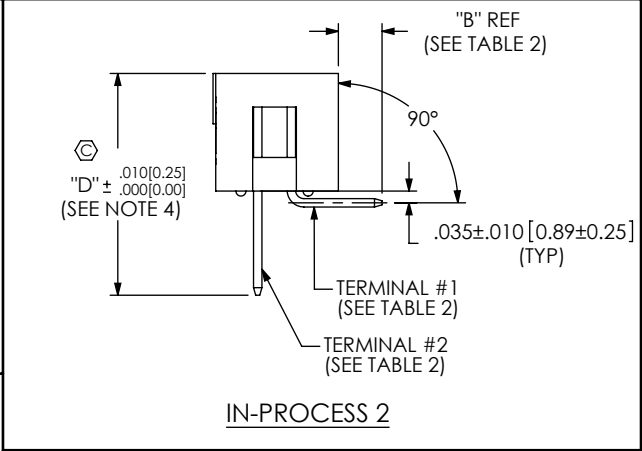
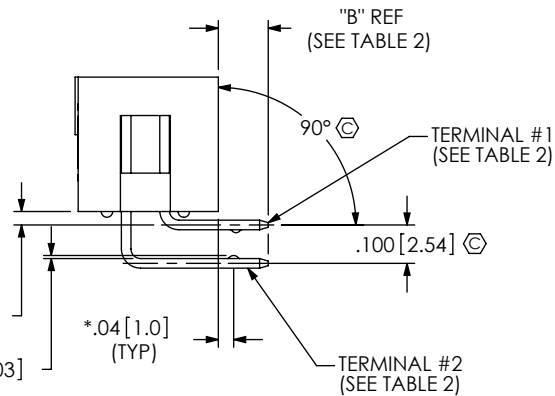

FIG 2
-RA & -LA OPTIONS
(HTST-111-04-XX-D-LA SHOWN)
(SAME AS FIG 1, UNLESS OTHERWISE STATED)
* DIMENSIONS APPLY WHEN USING -LA OPTION ONLY



TUBE PACKAGING VIEW FOR
04 & 05 LEAD STYLES

LEAD STYLE	"B"	"C"	"D"	TERMINAL #1	TERMINAL #2
-04	.130[3.30]	.280[7.11]	.830[21.08]	T-1S6-15-XX-2	T-1S6-10-XX-2
-05	.230[5.84]	.380[9.65]	.930[23.62]	T-1S6-09-XX-2	T-1S6-11-XX-2

Lead Style	Packaging	TUBES	PLUG
-01	Bulk	N/A	N/A
-02	Bulk	N/A	N/A
-03	Bulk	N/A	N/A
-04	Tube	PT-1-24-12T-109	TP-28
-05	Tube	PT-1-24-12T-109	TP-28

PROPRIETARY NOTE
THIS DOCUMENT CONTAINS INFORMATION
CONFIDENTIAL AND PROPRIETARY TO
SAMTEC, INC. AND SHALL NOT BE REPRODUCED
OR TRANSFERRED TO OTHER DOCUMENTS OR
DISCLOSED TO OTHERS OR USED FOR ANY
PURPOSE OTHER THAN THAT WHICH IT WAS
OBTAINED WITHOUT THE EXPRESSED WRITTEN
CONSENT OF SAMTEC, INC.

DO NOT SCALE DRAWING

SHEET SCALE: 2:1



520 PARK EAST BLVD, NEW ALBANY, IN 47150
PHONE: 812-944-6733 FAX: 812-948-5047
e-Mail: info@SAMTEC.com code: 55322

DESCRIPTION:
HIGH TEMP TOP SHROUD TERMINAL STRIP

DWG. NO.
HTST-1XX-XX-XX-D-XX-XX

BY: BRATCHER 01/16/04 SHEET 2 OF 2