



MSL1

\* Pb Free Part

Customer Name	Standard	TAIYO YUDEN Mobile Technology Co.,Ltd.	
System	W-CDMA Band II / CDMA2000 BC 1 Duplexer	Date	May. 25, 2011
Part Number	D6HK1G960DK12	Version 2.0ab	

**Table 1. Electrical Specification**

Item		Condition (MHz)	Specification			Unit	Remarks	
			Min	Typ	Max			
Tx to ANT	Insertion loss	1850.6~1909.4	-	2.0	2.9	dB (*1)		
		1850.48~1909.52	-	-	2.9	dB (*1)		
	Ripple	1850.48~1909.52	-	0.8	2.0	dB		
	VSWR	ANT	1850.48~1909.52	-	1.5	2.0	-	
		Tx		-	1.7	2.1	-	
	Absolute attenuation	1570~1580	38	41	-	dB		
		1930.6~1989.4	44	50	-	dB		
		1930.48~1989.52	44	-	-	dB		
		2400~2500	25	37	-	dB		
		3700~3820	22	27	-	dB		
5550~5730		15	19	-	dB			
ANT to Rx	Insertion loss	1930.6~1989.4	-	2.3	3.2	dB (*1)		
		1930.48~1989.52	-	-	3.2	dB (*1)		
	Ripple	1930.48~1989.52	-	1.4	2.5	dB		
	VSWR	ANT	1930.48~1989.52	-	1.8	2.2	-	
		Rx		-	1.8	2.2	-	
	Absolute attenuation	1850.6~1909.4	45	56	-	dB		
		1850.48~1909.52	45	-	-	dB		
2400~2500		35	50	-	dB			
Tx to Rx	Isolation	1850.6~1909.4	55	58	-	dB		
		1850.48~1909.52	55	-	-	dB		
		1930.6~1989.4	48	52	-	dB		
		1930.48~1989.52	48	-	-	dB		
Terminating Impedance	Tx port	50			Ohm	Single-ended		
	Rx port	50			Ohm	Single-ended		
	Ant port	50 // 4.3nH			Ohm	Single-ended		
Operating Temperature		-20 to +85			°C			
Device size (LxWxH)		2.5 x 2.0 x 0.65 Max			mm			

(\*1) Specification of insertion loss excludes loss that comes from the test board. ( approximately 0.15dB. )



MSL1

\* Pb Free Part

Customer Name	Standard	TAIYO YUDEN Mobile Technology Co.,Ltd.	
System	W-CDMA Band II / CDMA2000 BC 1 Duplexer	Date	May. 25, 2011
Part Number	D6HK1G960DK12	Version 2.0ab	

### Dimensions

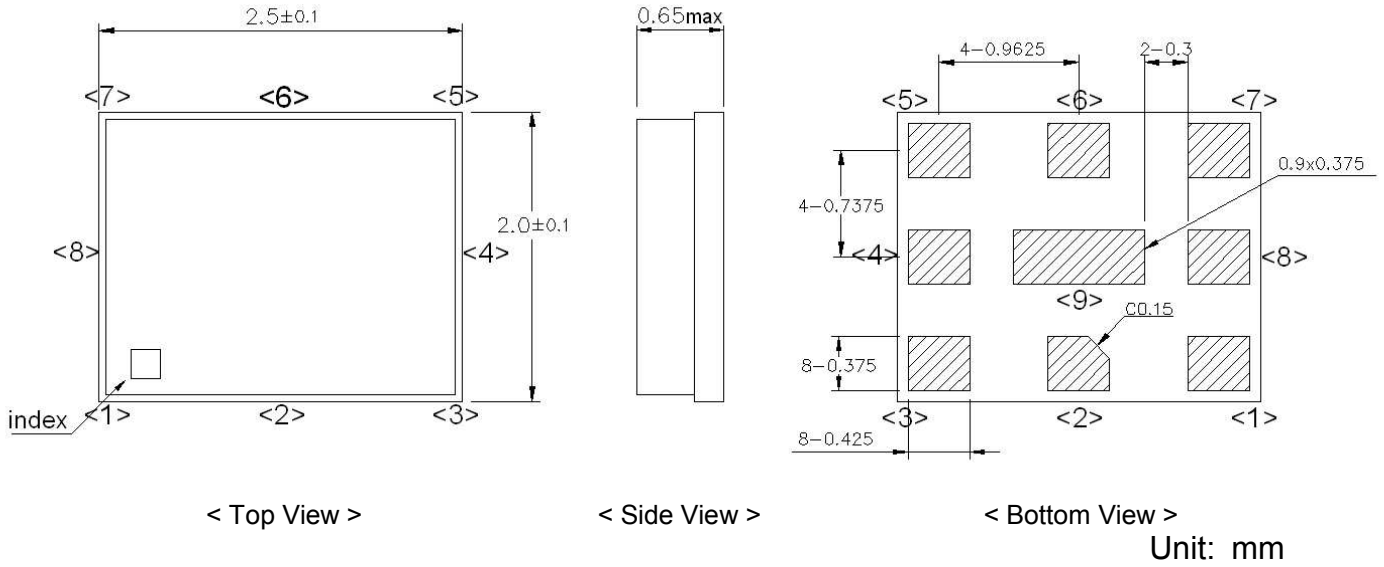

### Pin Configuration

Pin No.	Pin name	Description
1	Rx	Receiver Pin
2	GND	Ground Pin
3	Tx	Transmitter Pin
4	GND	Ground Pin
5	GND	Ground Pin
6	ANT	Antenna Pin
7	GND	Ground Pin
8	GND	Ground Pin
9	GND	Ground Pin

**Figure 1. Dimensions and Pin assignment**



MSL1

\* Pb Free Part

Customer Name	Standard	TAIYO YUDEN Mobile Technology Co.,Ltd.	
System	W-CDMA Band II / CDMA2000 BC 1 Duplexer	Date	May. 25, 2011
Part Number	D6HK1G960DK12	Version	2.0ab

### Evaluation Circuit

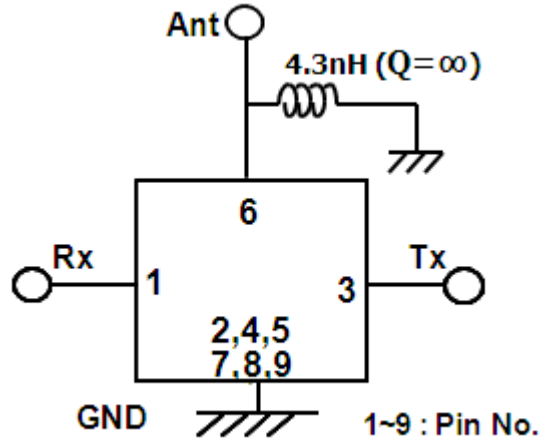

### Recommended foot print pattern

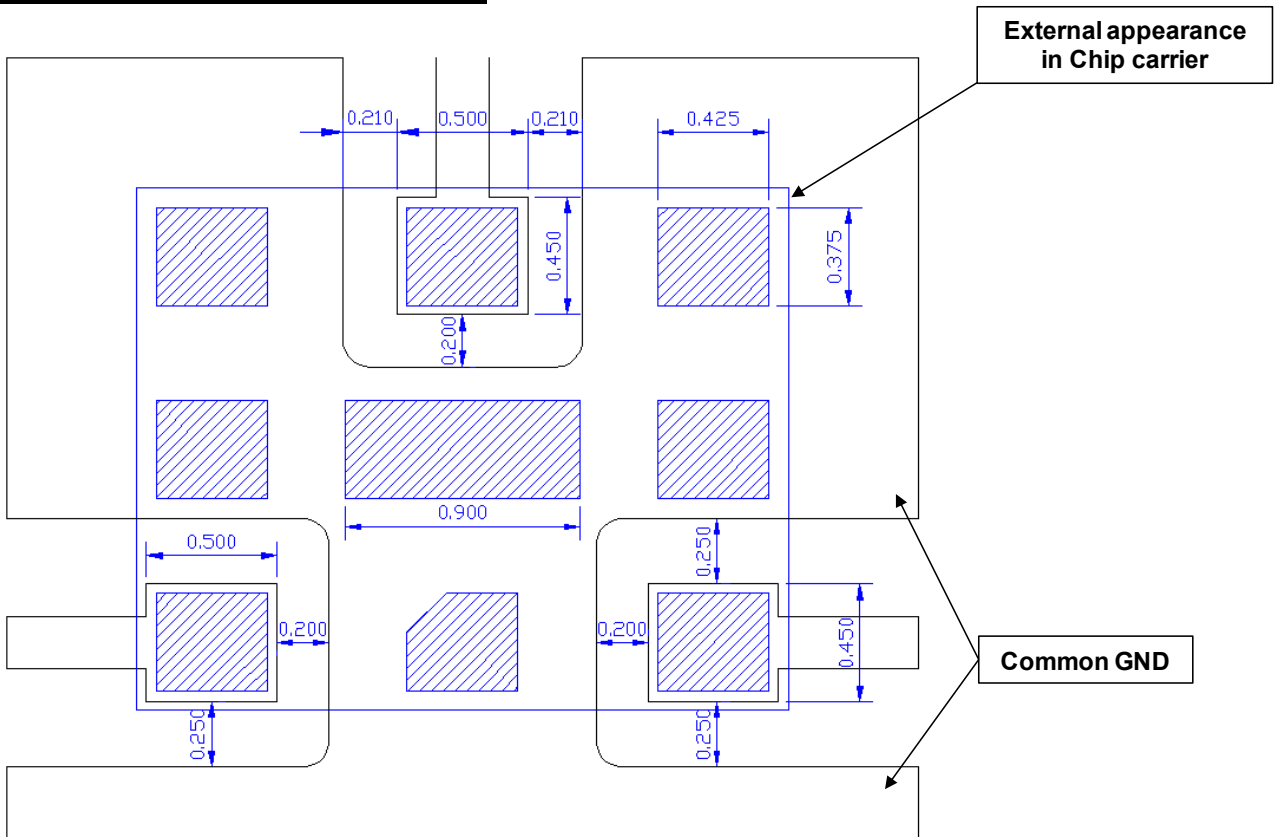

Figure 2. Recommended foot print pattern



MSL1

\* Pb Free Part

Customer Name	Standard	TAIYO YUDEN Mobile Technology Co.,Ltd.	
System	W-CDMA Band II / CDMA2000 BC 1 Duplexer	Date	May. 25, 2011
Part Number	D6HK1G960DK12	Version	2.0ab

### Tx to Ant

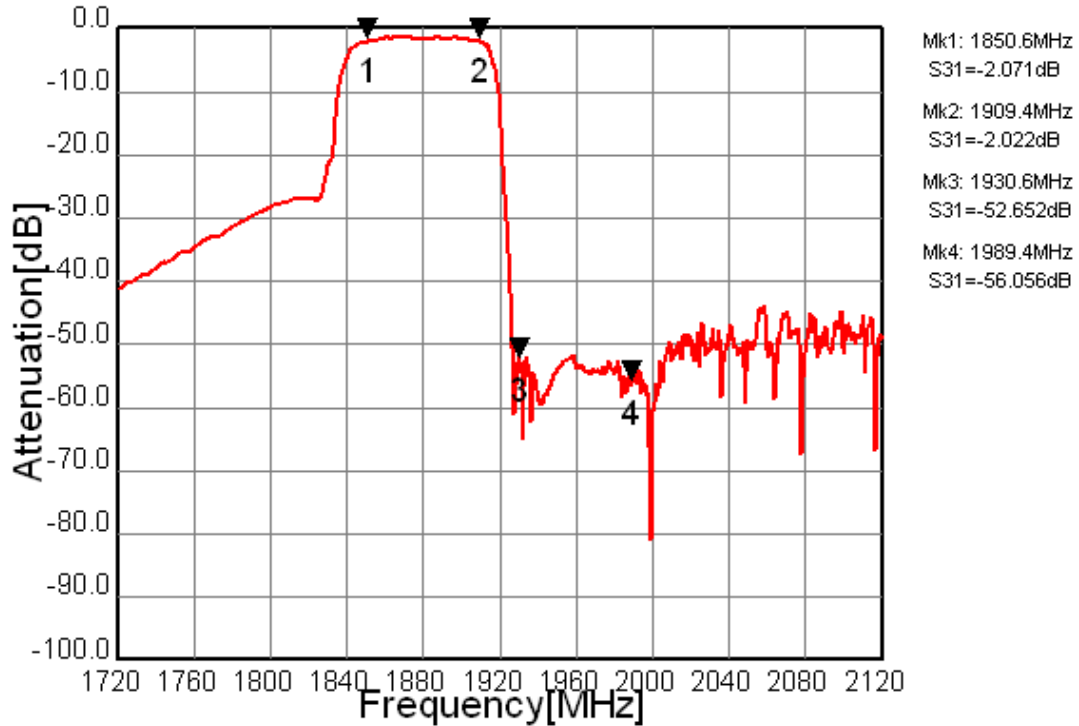

### Ant to Rx

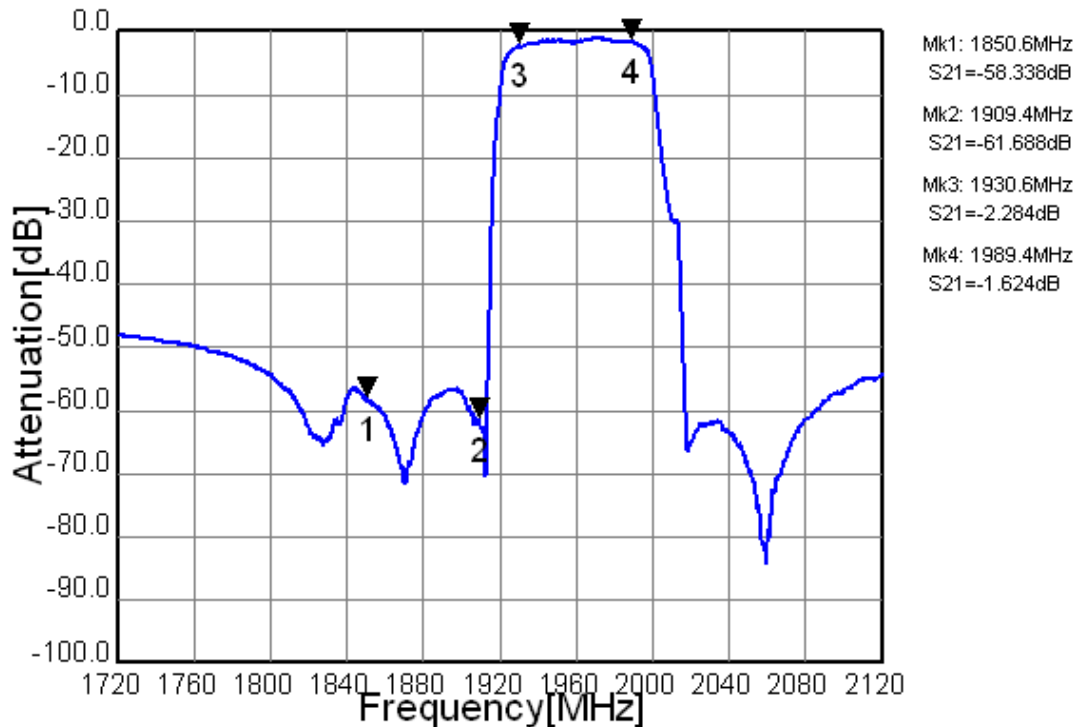

Figure 3-1. Electrical Characteristics

These data include loss that comes from the test board. ( Approximately 0.15dB. )



MSL1

\* Pb Free Part

Customer Name	Standard	TAIYO YUDEN Mobile Technology Co.,Ltd.	
System	W-CDMA Band II / CDMA2000 BC 1 Duplexer	Date	May. 25, 2011
Part Number	D6HK1G960DK12	Version	2.0ab

### Tx to Ant, Ant to Rx

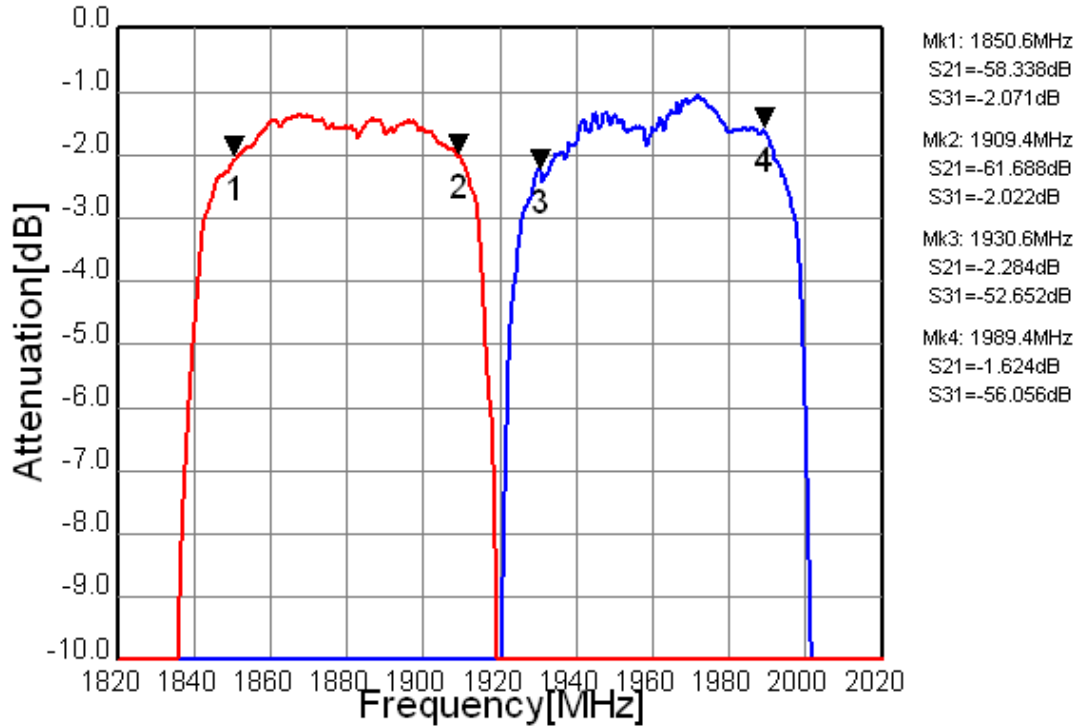

### Tx to Rx Isolation

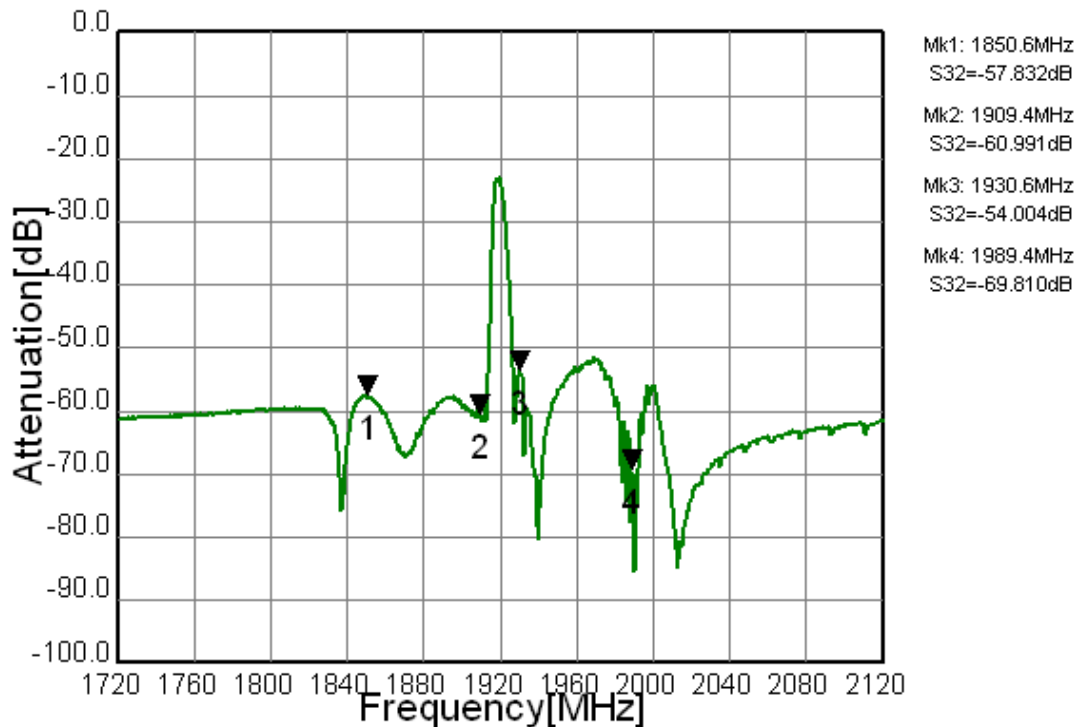

Figure 3-2. Electrical Characteristics

These data include loss that comes from the test board. ( Approximately 0.15dB. )



MSL1

\* Pb Free Part

Customer Name	Standard	TAIYO YUDEN Mobile Technology Co.,Ltd.	
System	W-CDMA Band II / CDMA2000 BC 1 Duplexer	Date	May. 25, 2011
Part Number	D6HK1G960DK12	Version	2.0ab

### Tx Port

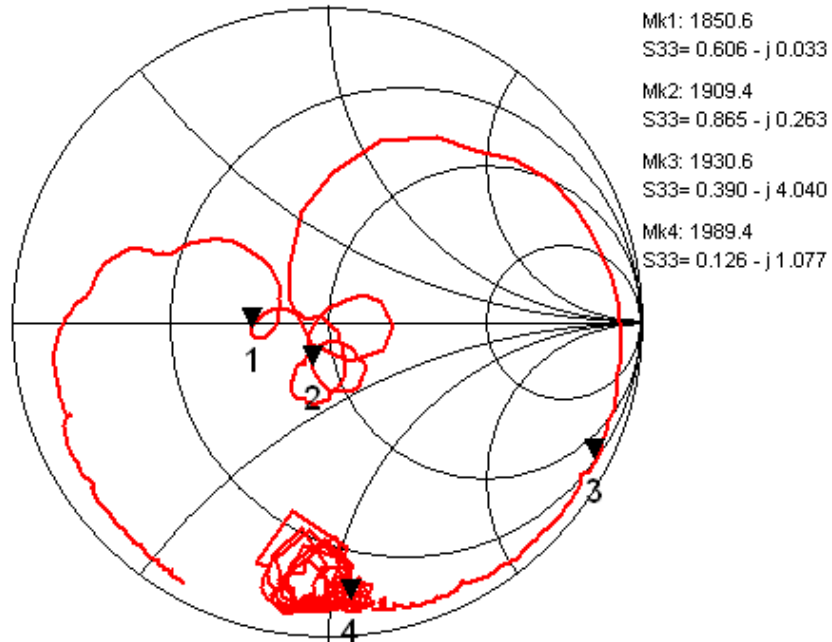
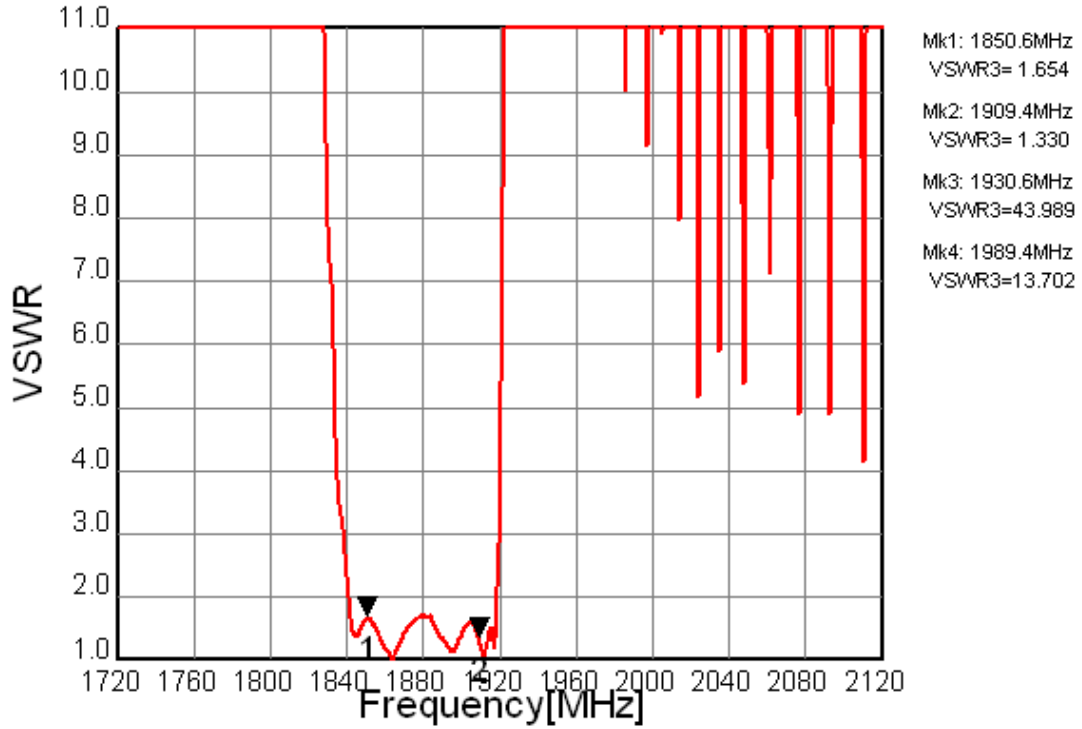

**Figure 3-3. Electrical Characteristics**



MSL1

\* Pb Free Part

Customer Name	Standard	TAIYO YUDEN Mobile Technology Co.,Ltd.	
System	W-CDMA Band II / CDMA2000 BC 1 Duplexer	Date	May. 25, 2011
Part Number	D6HK1G960DK12	Version	2.0ab

### Rx Port

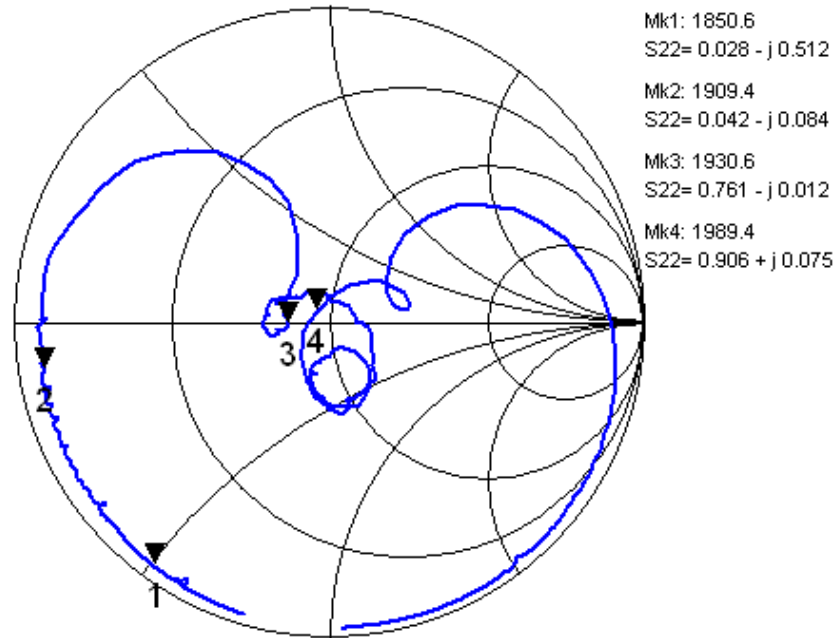
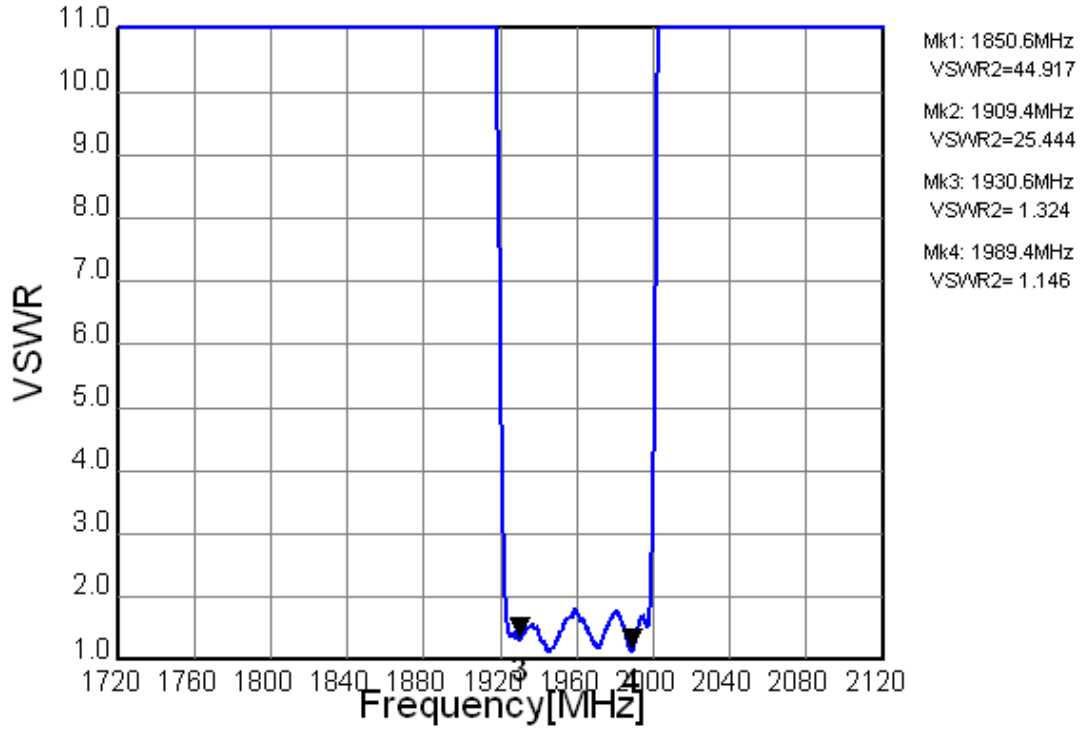

Figure 3-4. Electrical Characteristics



MSL1

\* Pb Free Part

Customer Name	Standard	TAIYO YUDEN Mobile Technology Co.,Ltd.	
System	W-CDMA Band II / CDMA2000 BC 1 Duplexer	Date	May. 25, 2011
Part Number	D6HK1G960DK12	Version	2.0ab

### Ant Port

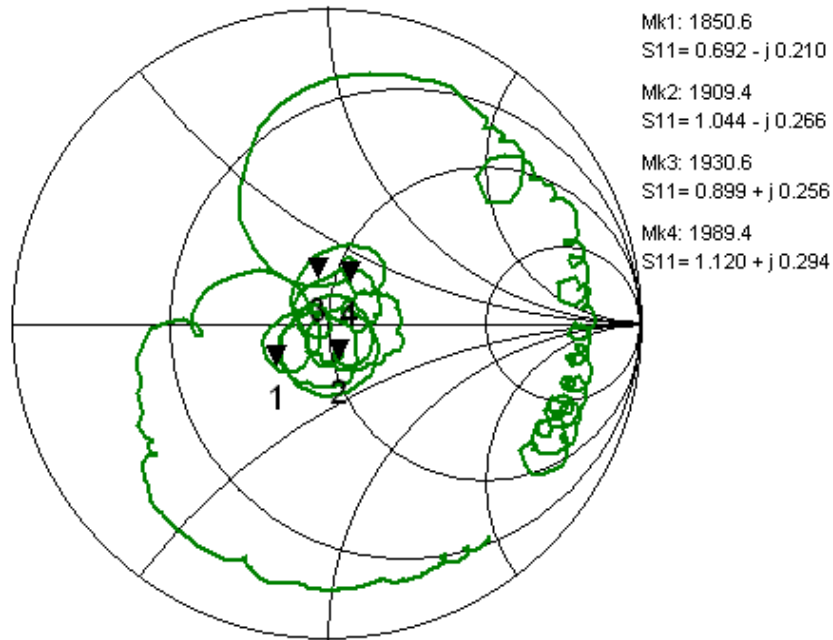
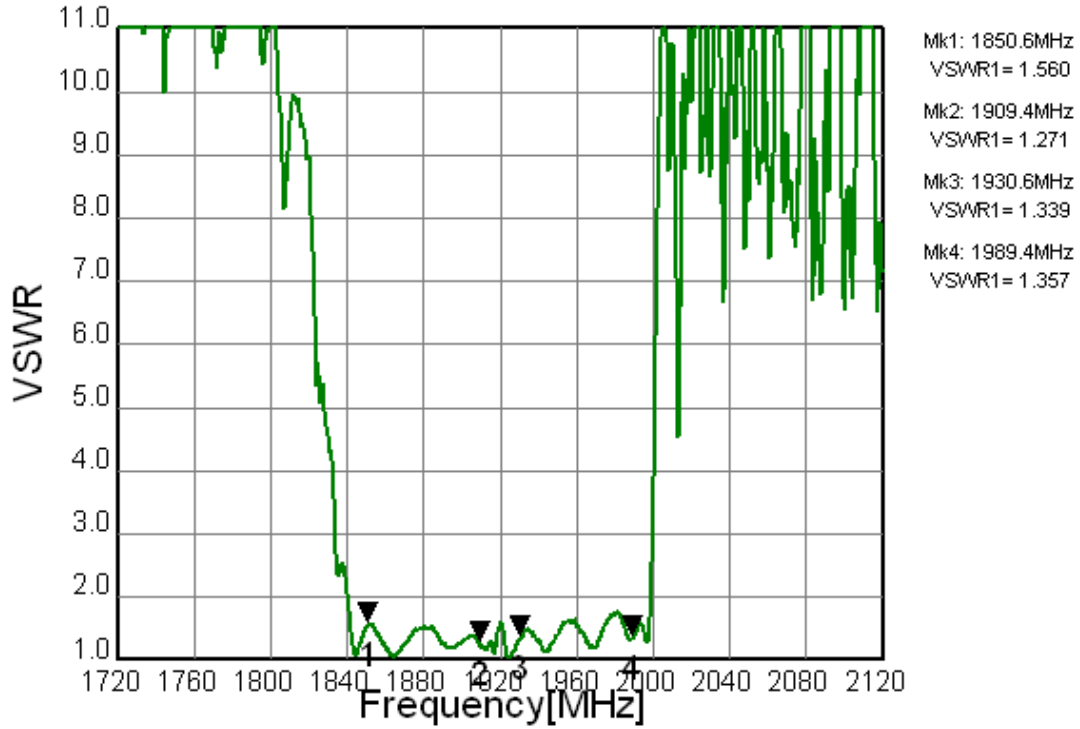

Figure 3-5. Electrical Characteristics



MSL1

\* Pb Free Part

Customer Name	Standard	TAIYO YUDEN Mobile Technology Co.,Ltd.	
System	W-CDMA Band II / CDMA2000 BC 1 Duplexer	Date	May. 25, 2011
Part Number	D6HK1G960DK12	Version	2.0ab

### Tx to Ant (Wide span)

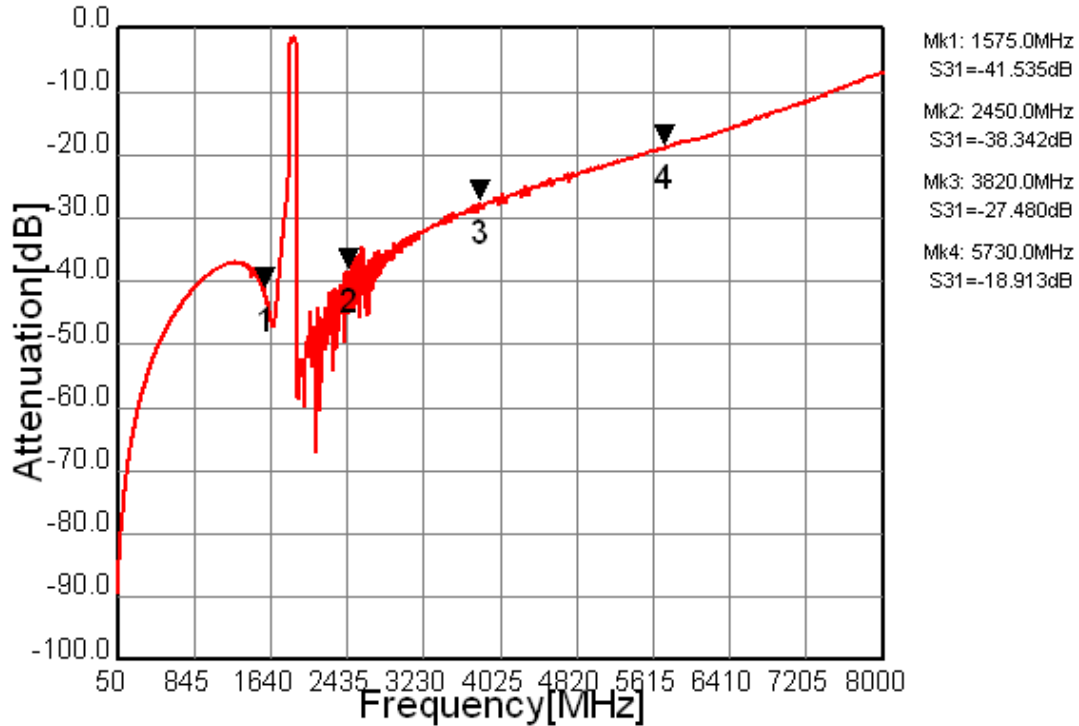

### Ant to Rx (Wide span)

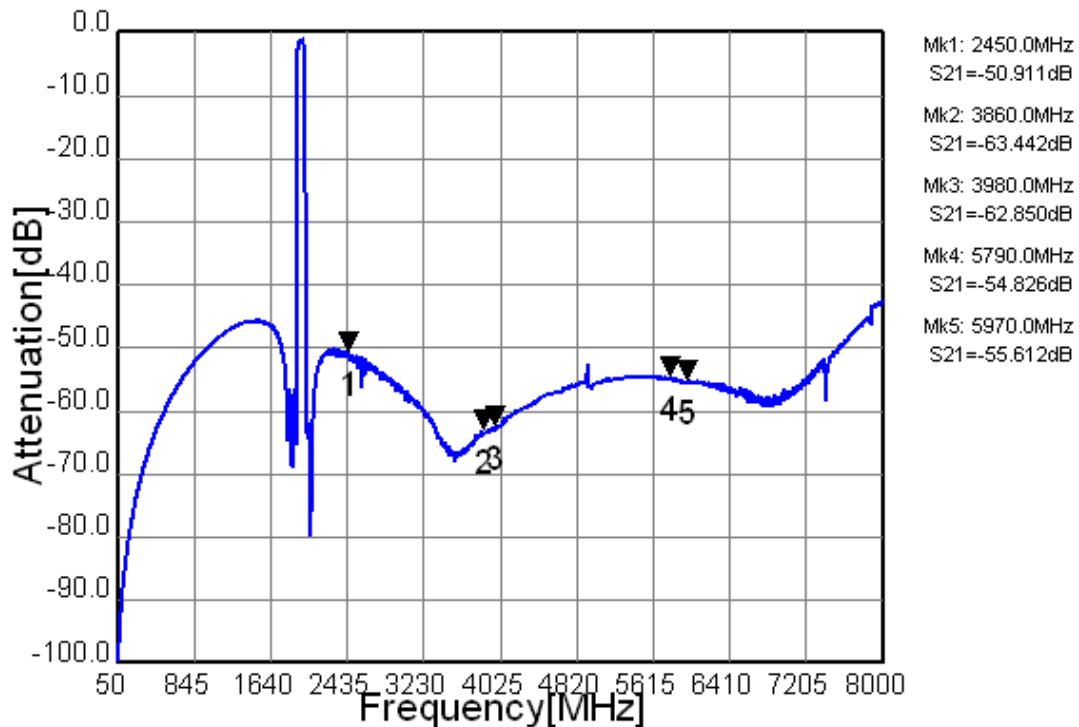

**Figure 3-6. Electrical Characteristics**



MSL1

\* Pb Free Part

Customer Name	Standard	TAIYO YUDEN Mobile Technology Co.,Ltd.	
System	W-CDMA Band II / CDMA2000 BC 1 Duplexer	Date	May. 25, 2011
Part Number	D6HK1G960DK12	Version 2.0ab	

## Ordering Code

Ordering Code	Packing	Reel size	Status
D6HK1G960DK12- <b>Z</b>	Tape & Reel	3,000 pcs.	MP
D6HK1G960DK12- <b>ZA</b>	Tape & Reel	less than 3,000 pcs.	MP
D6HK1G960DK12- <b>U</b>	Tape & Reel	10,000 pcs.	MP
D6HK1G960DK12- <b>UA</b>	Tape & Reel	less than 10,000 pcs.	MP
D6HK1G960DK12- <b>Q</b>	Bulk	few pcs.	MP

\*Minimum order quantity (MOQ) is assigned for each inquiry, Please contact to Sales Representatives..

\*MP : Mass Production

( For Engineering Sample (ES) order, please add a letter of "S" at the end of the ordering code indicated above. )

## Notice

All of the contents specified herein are subject to change without notice due to technical improvements, etc.

Please contact Taiyo Yuden Co., Ltd. for further details of product specifications.

Please conduct validation and verification of products in actual condition of mounting and operating environment before commercial shipment of the equipment.