

The ILLUMRA™ Thermostat uses wireless communication to provide quick and easy implementation of energy-saving HVAC controls.

When the thermostat receives an “occupied” signal from an ILLUMRA wireless switch or sensor, it adjusts temperature set point to a narrow preset range (i.e. 70°-72°F). When the thermostat receives an “unoccupied” signal, it adjusts temperature set points to a wider range (i.e. 62°-80°F). When used with a BMS Gateway, the thermostat can be connected to LON and BACNet HVAC control systems.

Easy-To-Use

- Installs in minutes
- Easy configuration
- Requires no switch leg wires

Reliable Range

- 50-150 foot range (typical)
- Compatible with many ILLUMRA transmitters
- Error checking ensures response only to appropriate wireless transmitters
- A single transmitter can control an unlimited number of the ILLUMRA Thermostats within range
- Repeaters available for added range

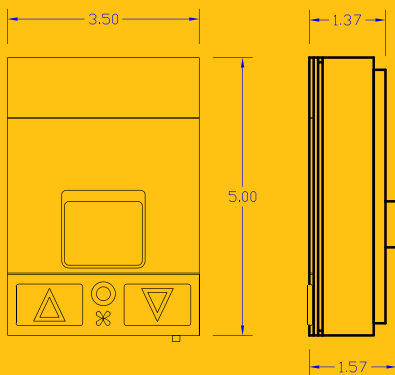

777 S. State St.
Orem, UT 84058

T: (801) 349-1200
F: (801) 653-4257
Sales@ILLUMRA.com
Info@ILLUMRA.com
www.ILLUMRA.com



Save Energy and Money

- Responds automatically to occupancy or vacancy
- Great for office, classroom, home, or hotel room
- Optional manual controls

Control The Way You Want It

Control the 24VAC Thermostat with a variety of devices:

- Wireless or wired occupancy sensors
- Key Card Access Switch
- SLT Wireless Sensor
- More

	E3X-T02-U2W
Range	50 to 150 feet (typical)
Frequency	315 MHz
Input Voltage	24 VAC
Max Loads	1.5 amp/circuit
Temperature Monitor Range	32.0°F to 99.9°F (0.0°C to 37.7°C)
Temperature Set Point Range	60°F to 85°F (15.5°C to 29.5°C)
Operating Temperature	14°F to 131°F (-10°C to 55°C)
Storage Temperature	-4°F to 131°F (-20°C to 55°C)
Sampling Rate	Every 5 seconds
Display Format	Liquid Crystal Display (LCD)
Fan Control	Selectable: Auto Cycle, Low, Medium, High, Economy, Off
Memory	Stores up to 30 switch IDs
Accuracy	+/- 1°F (0.5°C)
Heat/Cool Control	1 Heat and 1 Cool circuit, Heat pump reversing valve circuit
Dimensions	3.5 x 5.0 x 1.5 inches
Radio Certifications	FCC (U.S. SZV-TCM2XXC), IC (Canada 5713A-TCM2XXC)

Network Diagram

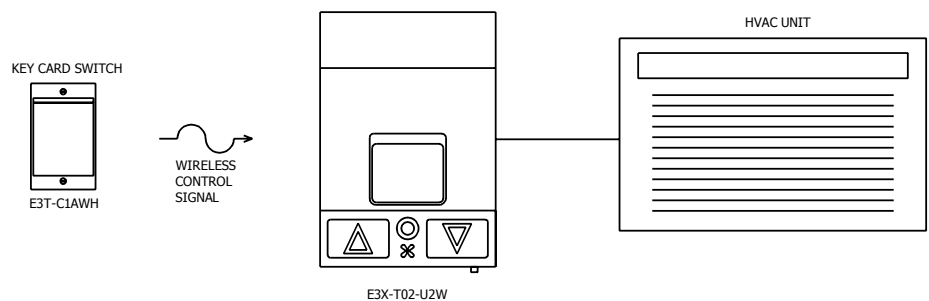

This device or certain aspects thereof is protected by at least one U.S. or international patent or has at least one such patent application pending.