

DATA SHEET

TDA8706A

**6-bit analog-to-digital converter
with multiplexer and clamp**

Product specification
Supersedes data of 1996 Jul 30

2003 Jul 21

6-bit analog-to-digital converter with multiplexer and clamp

TDA8706A

FEATURES

- 6-bit resolution
- Binary CMOS compatible outputs
- CMOS compatible digital inputs
- TLL clock input
- Three multiplexed video inputs
- R, G and B clamps on code 0
- Single 6-bit Analog-to-Digital Converter (ADC) operation allowed up to 40 MSPS
- External control of clamping level
- Internal reference voltage (external reference allowed)
- Power dissipation only 36 mW (typical)
- Operating temperature of -40 to $+85$ °C
- Operating between 2.7 and 3.6 V
- Sine wave clock allowed.

APPLICATIONS

- General purpose video applications
- R, G and B signals
- Automotive (car navigation)
- LCD systems
- Frame grabber.

GENERAL DESCRIPTION

The TDA8706A is a 6-bit ADC with three analog multiplexed inputs. Each input has an analog clamp on code 0 for RGB video processing. Clamping level can also be adjusted externally up to code 20. It can also be used as a single 6-bit ADC.

QUICK REFERENCE DATA

SYMBOL	PARAMETER	CONDITIONS	MIN.	TYP.	MAX.	UNIT
V_{DDA}	analog supply voltage		2.7	3.3	3.6	V
V_{DDD}	digital supply voltage		2.7	3.3	3.6	V
V_{DDO}	output stage supply voltage		2.7	3.3	3.6	V
I_{DDA}	analog supply current		–	6.4	10	mA
I_{DDD}	digital supply current		–	4.4	8.5	mA
I_{DDO}	output stage supply current	$f_{clk} = 40$ MHz; ramp input	–	–	1.8	mA
INL	integral non-linearity	$f_{clk} = 40$ MHz; ramp input	–	± 0.20	± 0.5	LSB
DNL	differential non-linearity	$f_{clk} = 40$ MHz; ramp input	–	± 0.10	± 0.35	LSB
$f_{clk(max)}$	maximum clock frequency		40	–	–	MHz
P_{tot}	total power dissipation	$f_{clk} = 40$ MHz; ramp input	–	36	73	mW

ORDERING INFORMATION

TYPE NUMBER	PACKAGE		
	NAME	DESCRIPTION	VERSION
TDA8706AM	SSOP24	plastic shrink small outline package; 24 leads; body width 5.3 mm	SOT340-1

6-bit analog-to-digital converter with multiplexer and clamp

TDA8706A

BLOCK DIAGRAM

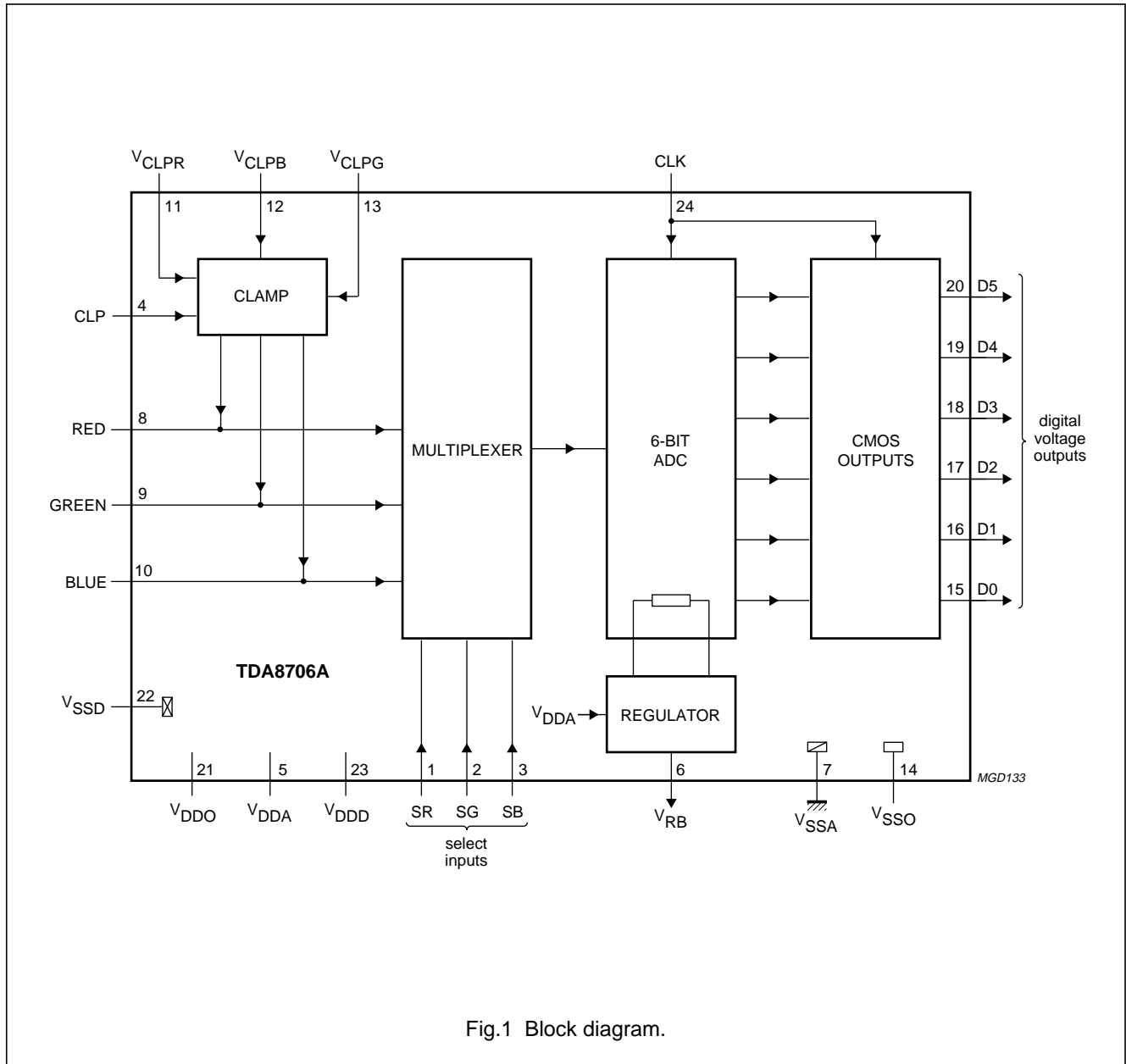

Fig.1 Block diagram.

6-bit analog-to-digital converter with multiplexer and clamp

TDA8706A

PINNING

SYMBOL	PIN	DESCRIPTION
SR	1	select input RED
SG	2	select input GREEN
SB	3	select input BLUE
CLP	4	clamping pulse input (positive pulse)
V _{DDA}	5	analog supply voltage
V _{RB}	6	reference voltage BOTTOM output
V _{SSA}	7	analog ground
RED	8	RED input
GREEN	9	GREEN input
BLUE	10	BLUE input
V _{CLPR}	11	RED clamping voltage level input
V _{CLPB}	12	BLUE clamping voltage level input
V _{CLPG}	13	GREEN clamping voltage level input
V _{SSO}	14	output stage ground
D0	15	digital voltage output; bit 0 (LSB)
D1	16	digital voltage output; bit 1
D2	17	digital voltage output; bit 2
D3	18	digital voltage output; bit 3
D4	19	digital voltage output; bit 4
D5	20	digital voltage output; bit 5
V _{DDO}	21	output stage supply voltage
V _{SSD}	22	digital ground
V _{DDD}	23	digital supply voltage
CLK	24	clock input

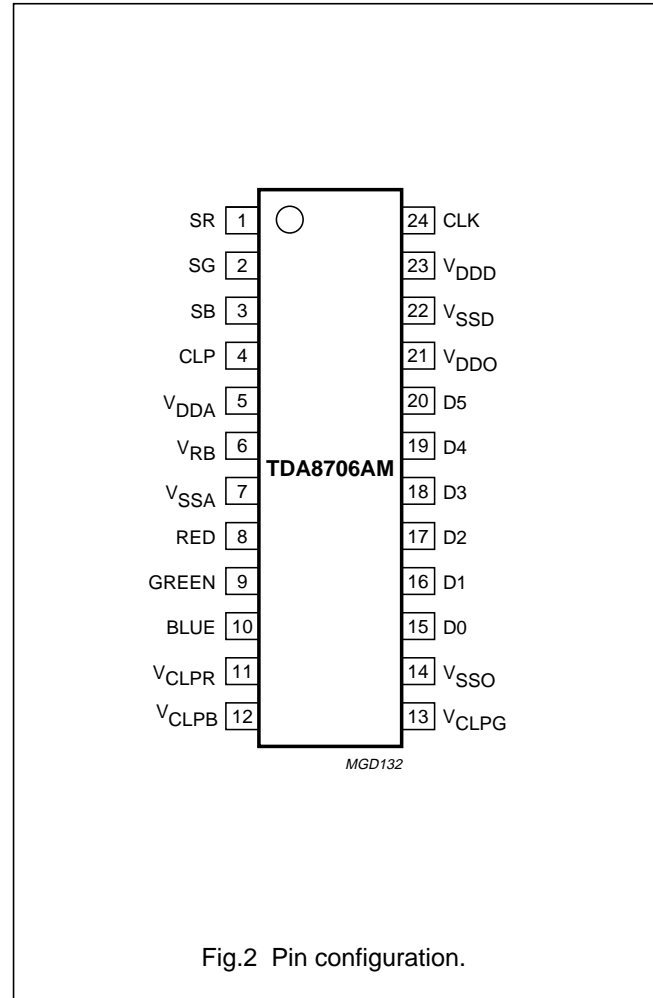

Fig.2 Pin configuration.

6-bit analog-to-digital converter with multiplexer and clamp

TDA8706A

LIMITING VALUES

In accordance with the Absolute Maximum Rating System (IEC 60134).

SYMBOL	PARAMETER	MIN.	MAX.	UNIT
V_{DDA}	analog supply voltage	-0.3	+7.0	V
V_{DDD}	digital supply voltage	-0.3	+7.0	V
ΔV_{DD}	supply voltage difference			
	$V_{DDA} - V_{DDD}$	-1.0	+1.0	V
	$V_{DDA} - V_{DDO}$	-1.0	+1.0	V
	$V_{DDD} - V_{DDO}$	-1.0	+1.0	V
V_I	input voltage	-0.3	+7.0	V
I_O	output current	-	10	mA
T_{stg}	storage temperature	-55	+150	°C
T_{amb}	operating ambient temperature	-40	+85	°C
T_j	junction temperature	-	150	°C

HANDLING

Inputs and outputs are protected against electrostatic discharge in normal handling. However, to be totally safe, it is desirable to take normal precautions appropriate to handling integrated circuits.

THERMAL CHARACTERISTICS

SYMBOL	PARAMETER	CONDITIONS	VALUE	UNIT
$R_{th(j-a)}$	thermal resistance from junction to ambient	in free air	119	K/W

CHARACTERISTICS

$V_{DDA} = 2.7$ to 3.6 V; $V_{DDD} = 2.7$ to 3.6 V; $V_{DDO} = 2.7$ to 3.6 V; V_{SSA} , V_{SSD} and V_{SSO} shorted together; $V_{i(p-p)} = 0.7$ V; $T_{amb} = -40$ to $+85$ °C; typical values measured at $V_{DDA} = V_{DDD} = V_{DDO} = 3.3$ V and $T_{amb} = 25$ °C; unless otherwise specified.

SYMBOL	PARAMETER	CONDITIONS	MIN.	TYP.	MAX.	UNIT
Supply						
V_{DDA}	analog supply voltage		2.7	3.3	3.6	V
V_{DDD}	digital supply voltage		2.7	3.3	3.6	V
V_{DDO}	output stage supply voltage		2.7	3.3	3.6	V
ΔV_{DD}	supply voltage difference					
	$V_{DDA} - V_{DDD}$		-0.3	-	+0.3	V
	$V_{DDA} - V_{DDO}$		-0.3	-	+0.3	V
	$V_{DDD} - V_{DDO}$		-0.3	-	+0.3	V
I_{DDA}	analog supply current		-	6.4	10	mA
I_{DDD}	digital supply current		-	4.4	8.5	mA
I_{DDO}	output stage supply current	$f_{clk} = 40$ MHz; ramp input	-	-	1.8	mA

6-bit analog-to-digital converter with multiplexer and clamp

TDA8706A

SYMBOL	PARAMETER	CONDITIONS	MIN.	TYP.	MAX.	UNIT
P_{tot}	total power dissipation		–	36	73	mW
Inputs						
CLOCK INPUT CLK (REFERENCED TO V_{SSD}); note 1						
V_{IL}	LOW-level input voltage		0	–	0.8	V
V_{IH}	HIGH-level input voltage		2.0	–	V_{DDD}	V
I_{IL}	LOW-level input current	$V_{clk} = 0.8$ V	–1	0	+1	μ A
I_{IH}	HIGH-level input current	$V_{clk} = 2.0$ V	–	2	10	μ A
Z_i	input impedance	$f_{clk} = 40$ MHz	–	4	–	k Ω
C_i	input capacitance	$f_{clk} = 40$ MHz	–	3	–	pF
INPUTS SR, SG, SB AND CLP (REFERENCED TO V_{SSD})						
V_{IL}	LOW-level input voltage		0	–	$V_{DDD} \times 0.3$	V
V_{IH}	HIGH-level input voltage		$V_{DDD} \times 0.7$	–	V_{DDD}	V
I_{IL}	LOW-level input current	$V_{IL} = V_{DDD} \times 0.2$	–1	–	–	μ A
I_{IH}	HIGH-level input current	$V_{IH} = V_{DDD} \times 0.8$	–	–	+1	μ A
INPUTS V_{CLPR} , V_{CLPG} AND V_{CLPB} (REFERENCED TO V_{SSA}); see Tables 1 and 2						
V_{CLP}	input voltage for clamping		$V_{code(-9)}$	–	$V_{code(20)}$	V
I_{CLP}	input current		–	–	30	μ A
A_{CLP}	clamp accuracy	between inputs RED, GREEN and BLUE of each device; $T_{amb} = 25$ °C	–1	–	+1	LSB
ANALOG INPUTS RED, GREEN AND BLUE; see Table 1						
$V_{i(p-p)}$	input voltage amplitude (peak-to-peak value)		0.63	0.70	0.77	V
I_i	input current		–	–	10	μ A
C_{clamp}	clamp coupling capacitance		1	10	100	nF
Reference voltages for the resistor ladder; see Table 1						
V_{RB}	BOTTOM reference voltage		$V_{DDA} - 1.29$	$V_{DDA} - 1.21$	$V_{DDA} - 1.13$	V
Outputs						
DIGITAL OUTPUTS D5 TO D0 (REFERENCED TO V_{SSD})						
V_{OL}	LOW-level output voltage	$I_O = 1$ mA	0	–	0.5	V
V_{OH}	HIGH-level output voltage	$I_O = -1$ mA	$V_{DDO} - 0.5$	–	V_{DDO}	V
Switching characteristics						
CLOCK INPUT CLK; see Fig.3; note 1						
$f_{clk(max)}$	maximum clock frequency		40	–	–	MHz
$f_{mux(max)}$	maximum multiplexer frequency		20	–	–	MHz
t_{CPH}	clock pulse width HIGH		9	–	–	ns
t_{CPL}	clock pulse width LOW		9	–	–	ns

6-bit analog-to-digital converter with multiplexer and clamp

TDA8706A

SYMBOL	PARAMETER	CONDITIONS	MIN.	TYP.	MAX.	UNIT
t_r	clock rise time	10% to 90%; $f_{clk} \leq 40$ MHz; LOW = 0.8 V, HIGH = 2.0 V	–	–	7	ns
t_f	clock fall time	90% to 10%; $f_{clk} \leq 40$ MHz; LOW = 0.8 V, HIGH = 2.0 V	–	–	7	ns
Analog signal processing						
LINEARITY						
INL	integral non-linearity	$f_{clk} = 40$ MHz; ramp input	–	± 0.20	± 0.5	LSB
DNL	differential non-linearity	$f_{clk} = 40$ MHz; ramp input	–	± 0.10	± 0.35	LSB
EFFECTIVE BITS; note 2						
EB	effective bits	$f_{clk} = 40$ MHz; $f_i = 4.43$ MHz	5.5	5.8	–	bits
Timing ($f_{clk} = 40$ MHz; $C_L = 10$ pF); see Fig.3						
OUTPUT DATA; note 3						
t_{ds}	sampling delay time		–	–	7	ns
t_h	output hold time		6.5	9.0	–	ns
t_d	output delay time		–	12	19	ns
SELECT INPUT SIGNALS SR, SG, SB AND CLP						
t_{su}	set-up time SR, SG and SB	with no overlap; see Fig.3	10	–	–	ns
		with overlap; see Fig.4	–	–	–	ns
t_r	rise time SR, SG and SB	10% to 90%	4	6	–	ns
t_f	fall time SR, SG and SB	90% to 10%	4	6	–	ns
t_{over}	RED, GREEN and BLUE (active) overlap time with respect to select signals SR, SG and SB	see Fig.4	0	–	–	ns
t_{CLPP}	clamp pulse time	$C_{CLP} = 10$ nF	–	3	–	μ s
t_{MH}	multiplexer hold time SR, SG and SB		9	–	–	ns

Notes

- In addition to a good layout of the digital and analog ground, it is recommended that the rise and fall times of the clock must not be less than 1 ns. A sine wave with specified amplitude is also allowed.
- Effective bits are derived from a Fast Fourier Transform (FFT) processing taking 2K acquisition points per equivalent fundamental period. The calculation takes into account all harmonics and noise up to half of the clock frequency (NYQUIST frequency). Conversion to signal-to-noise ratio: $S/N = EB \times 6.02 + 1.76$ dB.
- Output data acquisition: the output data is available after the maximum delay time t_d .

6-bit analog-to-digital converter
with multiplexer and clamp

TDA8706A

Table 1 Output coding and input voltage (typical values); $V_{DDA} = V_{DDD} = 3.3\text{ V}$

STEP	V_i (V)	BINARY OUTPUT BITS					
		D5	D4	D3	D2	D1	D0
Underflow	$<V_{DDA} - 1.12$	0	0	0	0	0	0
0	$V_{DDA} - 1.12$	0	0	0	0	0	0
1	.	0	0	0	0	0	1
.
.
62	.	1	1	1	1	1	0
63	$V_{DDA} - 0.42$	1	1	1	1	1	1
Overflow	$>V_{DDA} - 0.42$	1	1	1	1	1	1

Table 2 Clamping input level (V_{CLPR} , V_{CLPG} and V_{CLPB})

V_{CLPR} , V_{CLPG} , V_{CLPB}	CLAMPING LEVEL
Open-circuit ⁽¹⁾	code 0
$V_{code(-9)}$ to $V_{code(20)}$	code -9 to code 20

Note

- 1. Use capacitor $\geq 10\text{ pF}$ to V_{SSA} .

Table 3 Clamp and inputs RED, GREEN and BLUE; $V_{DDA} = V_{DDD} = V_{DDO} = 3.3\text{ V}$

SR or SG or SB	CLAMP	V_{CLPR} , V_{CLPG} or V_{CLPB}	V_i RED or GREEN or BLUE	DIGITAL OUTPUTS
0	1	open	$V_{DDA} - 1.12\text{ V}$	don't care
		V_{CLP}	V_{CLP}	
open		$V_{DDA} - 1.12\text{ V}$	0	
V_{CLP}		V_{CLP}	code (V_{CLP})	

6-bit analog-to-digital converter
with multiplexer and clamp

TDA8706A

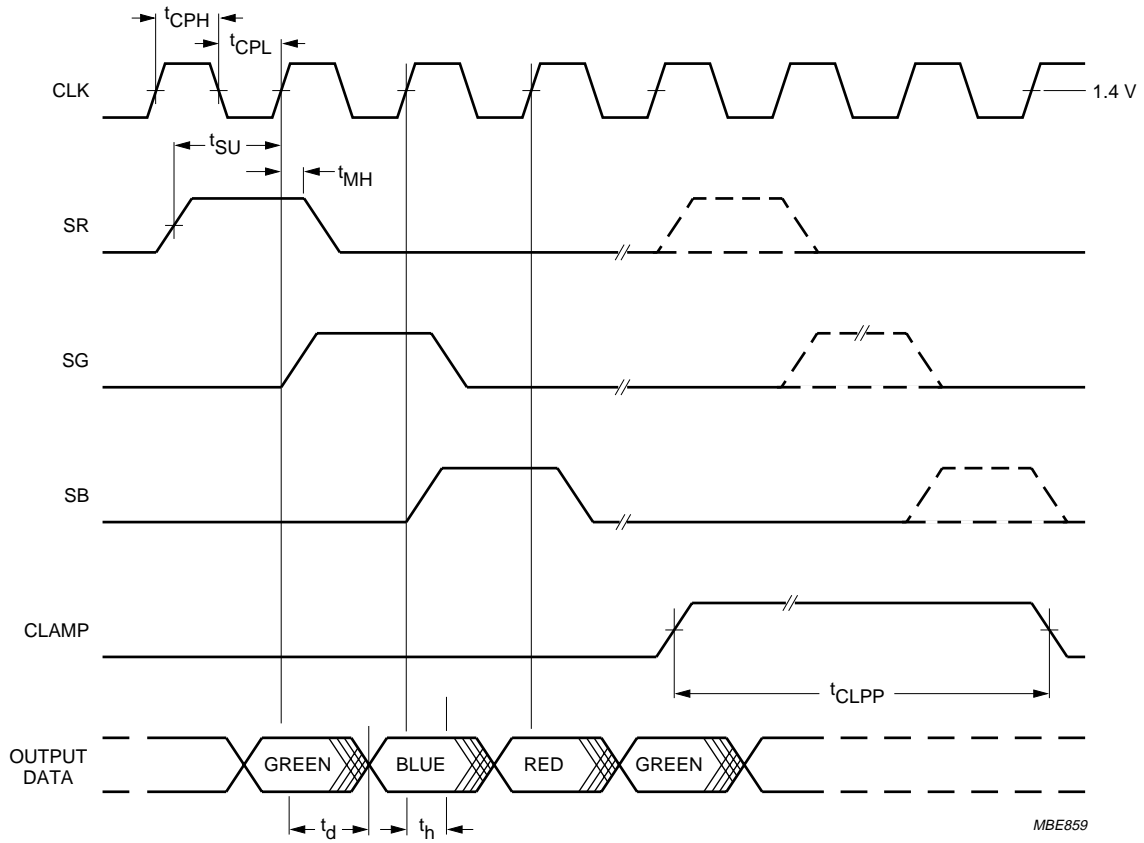

Fig.3 AC characteristics select signals, clamp and output data.

MBE859

6-bit analog-to-digital converter
with multiplexer and clamp

TDA8706A

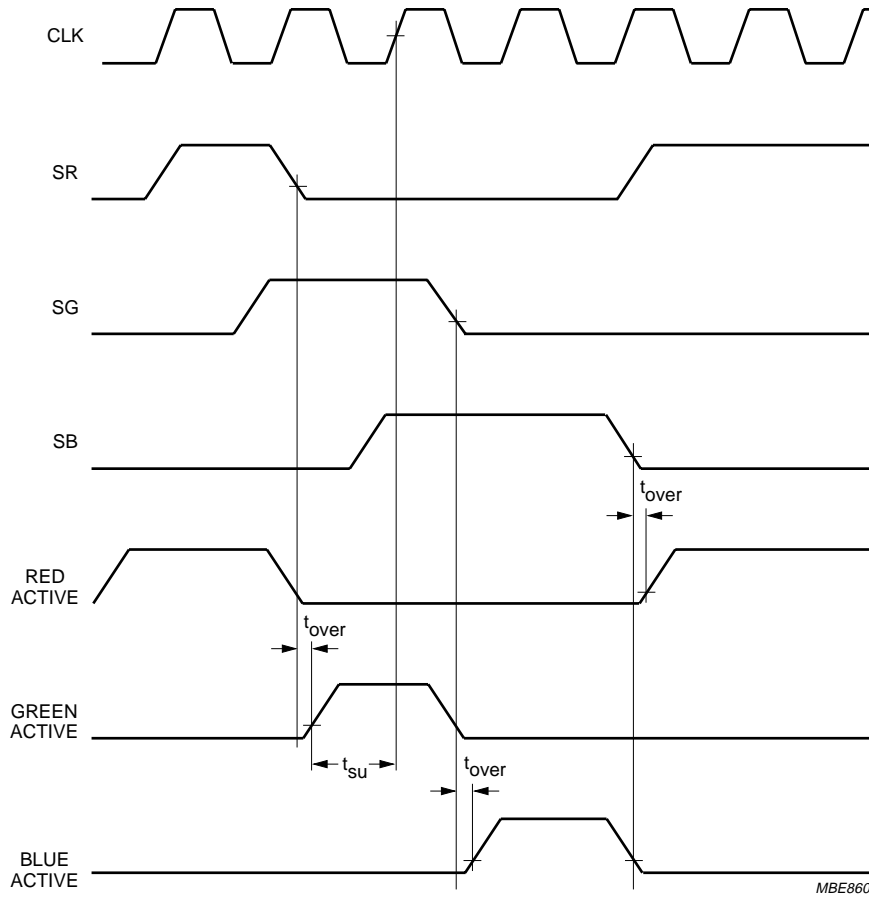

Fig.4 Anti-overlap system for analog multiplexer.

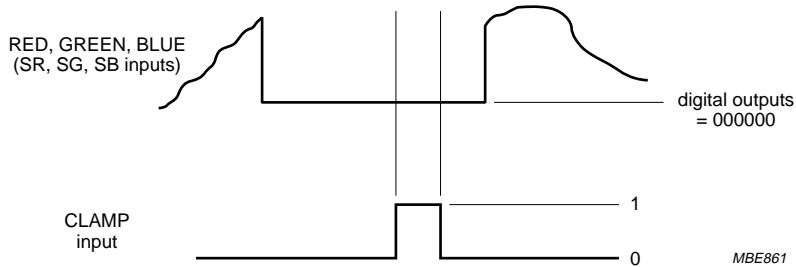
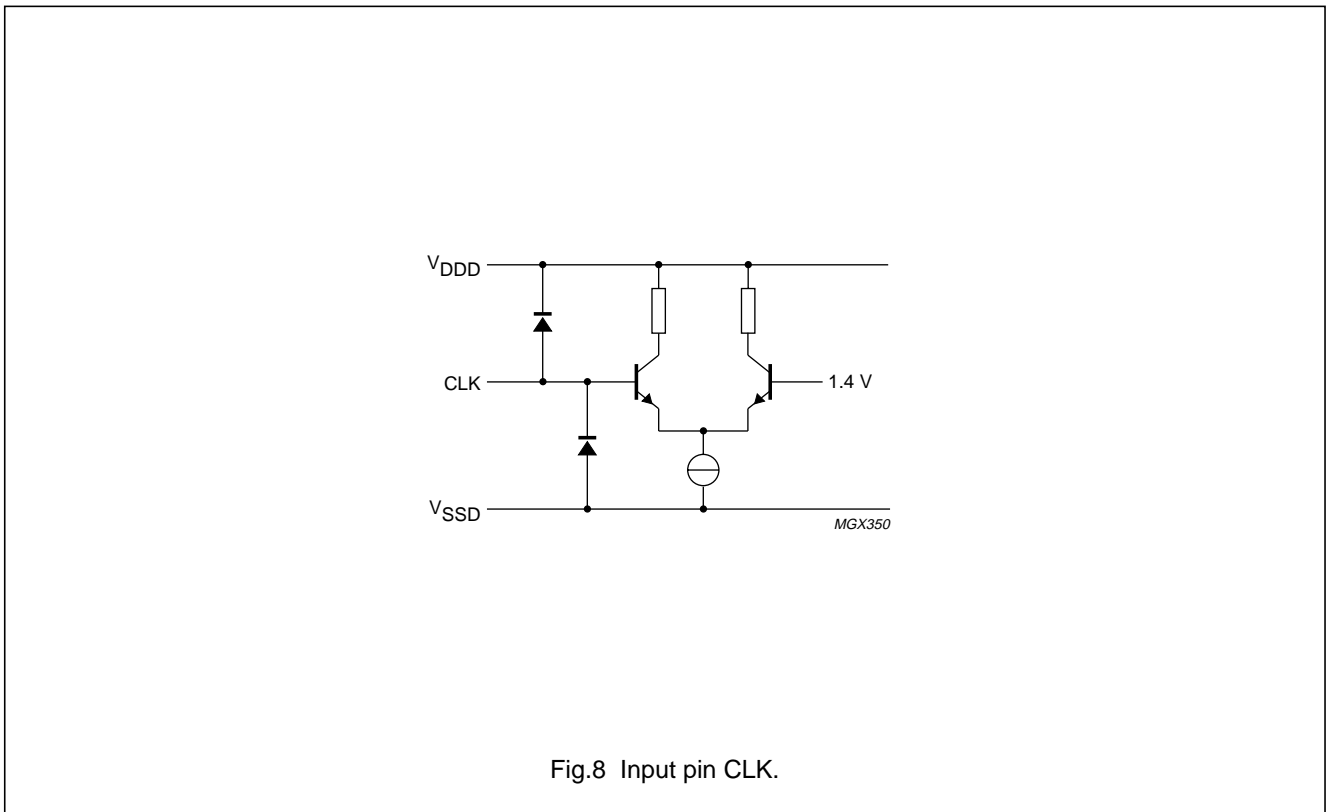
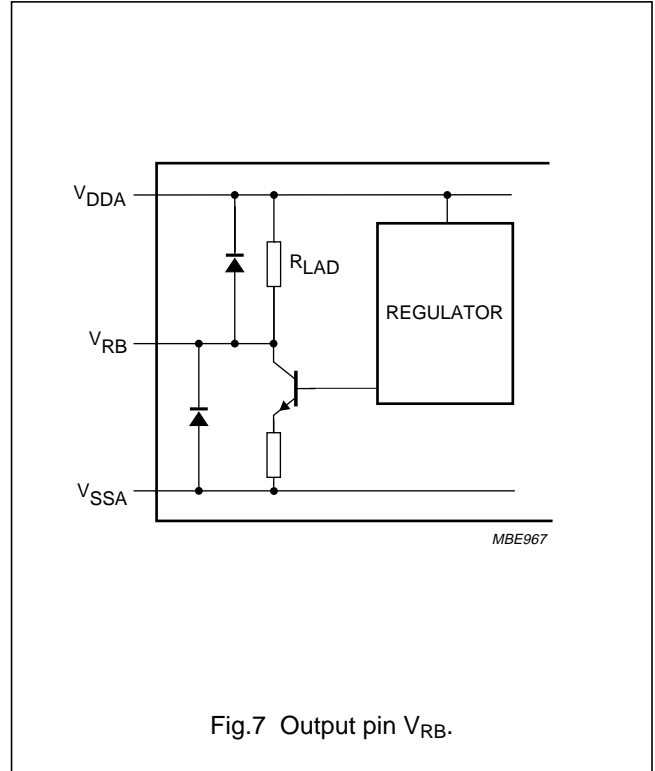
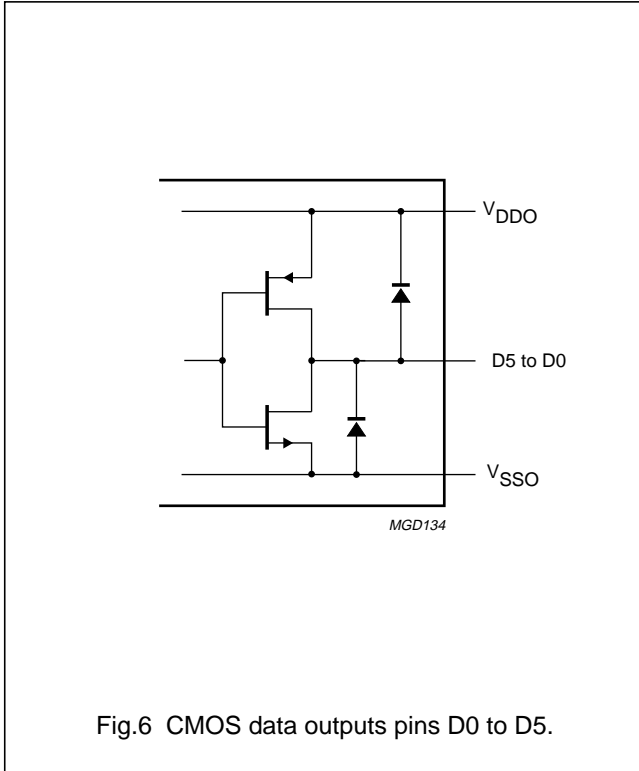

Fig.5 AC characteristics select signals; clamp and data.

6-bit analog-to-digital converter with multiplexer and clamp

TDA8706A

INTERNAL PIN CONFIGURATIONS



6-bit analog-to-digital converter with multiplexer and clamp

TDA8706A

APPLICATION INFORMATION

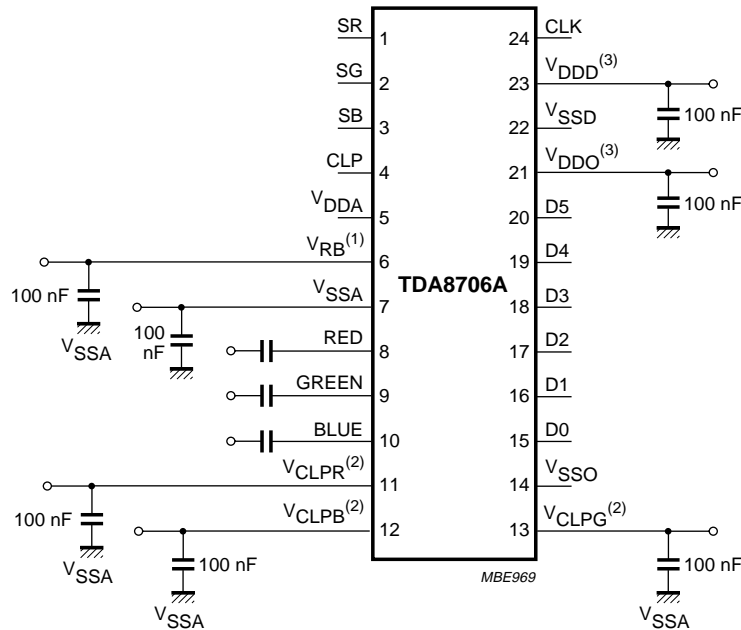

The analog and digital supplies should be separated and decoupled.

V_{DDO} should be well decoupled with its capacitor in order to be as close as possible to its pin.

V_{RB} must not be connected to V_{CLPR} , V_{CLPB} or V_{CLPG} pins.

For applications where the black level is clamped to code 0, V_{CLPR} , V_{CLPB} and V_{CLPG} must be left open-circuit with their respective decoupling capacitors. In that event, they may also be connected together in order to use only one single decoupling capacitor.

- (1) V_{RB} is decoupled to V_{SSA} . An external regulator can also be connected to V_{RB} .
- (2) V_{CLPR} , V_{CLPB} and V_{CLPG} are decoupled to V_{SSA} . External voltages can also be forced on V_{CLPR} , V_{CLPB} and V_{CLPG} .
- (3) V_{DDO} and V_{DDD} can be shorted together but the decoupling capacitors should remain as close as possible to its pin.

Fig.9 Application diagram.

6-bit analog-to-digital converter
with multiplexer and clamp

TDA8706A

PACKAGE OUTLINE

SSOP24: plastic shrink small outline package; 24 leads; body width 5.3 mm

SOT340-1

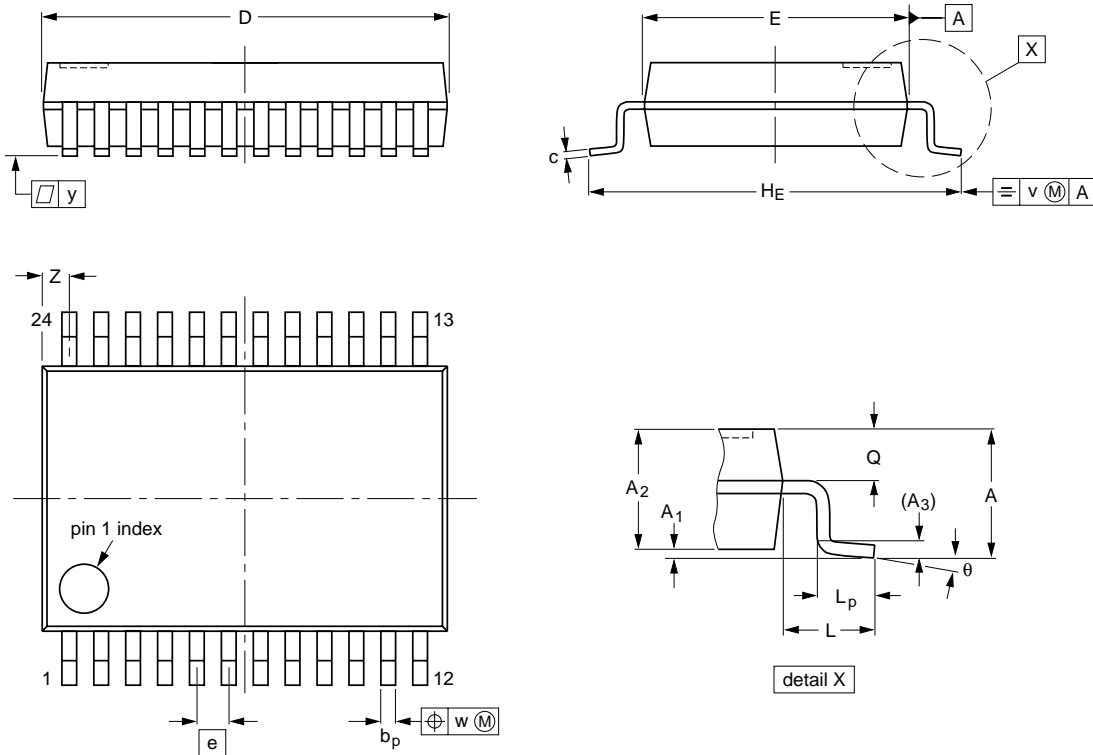

DIMENSIONS (mm are the original dimensions)

UNIT	A max.	A ₁	A ₂	A ₃	b _p	c	D ⁽¹⁾	E ⁽¹⁾	e	H _E	L	L _p	Q	v	w	y	Z ⁽¹⁾	θ
mm	2	0.21 0.05	1.80 1.65	0.25	0.38 0.25	0.20 0.09	8.4 8.0	5.4 5.2	0.65	7.9 7.6	1.25	1.03 0.63	0.9 0.7	0.2	0.13	0.1	0.8 0.4	8° 0°

Note

1. Plastic or metal protrusions of 0.2 mm maximum per side are not included.

OUTLINE VERSION	REFERENCES				EUROPEAN PROJECTION	ISSUE DATE
	IEC	JEDEC	JEITA			
SOT340-1		MO-150				99-12-27 03-02-19

6-bit analog-to-digital converter with multiplexer and clamp

TDA8706A

SOLDERING

Introduction to soldering surface mount packages

This text gives a very brief insight to a complex technology. A more in-depth account of soldering ICs can be found in our *"Data Handbook IC26; Integrated Circuit Packages"* (document order number 9398 652 90011).

There is no soldering method that is ideal for all surface mount IC packages. Wave soldering can still be used for certain surface mount ICs, but it is not suitable for fine pitch SMDs. In these situations reflow soldering is recommended.

Reflow soldering

Reflow soldering requires solder paste (a suspension of fine solder particles, flux and binding agent) to be applied to the printed-circuit board by screen printing, stencilling or pressure-syringe dispensing before package placement.

Several methods exist for reflowing; for example, convection or convection/infrared heating in a conveyor type oven. Throughput times (preheating, soldering and cooling) vary between 100 and 200 seconds depending on heating method.

Typical reflow peak temperatures range from 215 to 250 °C. The top-surface temperature of the packages should preferably be kept:

- below 220 °C for all the BGA packages and packages with a thickness ≥ 2.5 mm and packages with a thickness < 2.5 mm and a volume ≥ 350 mm³ so called thick/large packages
- below 235 °C for packages with a thickness < 2.5 mm and a volume < 350 mm³ so called small/thin packages.

Wave soldering

Conventional single wave soldering is not recommended for surface mount devices (SMDs) or printed-circuit boards with a high component density, as solder bridging and non-wetting can present major problems.

To overcome these problems the double-wave soldering method was specifically developed.

If wave soldering is used the following conditions must be observed for optimal results:

- Use a double-wave soldering method comprising a turbulent wave with high upward pressure followed by a smooth laminar wave.
- For packages with leads on two sides and a pitch (e):
 - larger than or equal to 1.27 mm, the footprint longitudinal axis is **preferred** to be parallel to the transport direction of the printed-circuit board;
 - smaller than 1.27 mm, the footprint longitudinal axis **must** be parallel to the transport direction of the printed-circuit board.

The footprint must incorporate solder thieves at the downstream end.

- For packages with leads on four sides, the footprint must be placed at a 45° angle to the transport direction of the printed-circuit board. The footprint must incorporate solder thieves downstream and at the side corners.

During placement and before soldering, the package must be fixed with a droplet of adhesive. The adhesive can be applied by screen printing, pin transfer or syringe dispensing. The package can be soldered after the adhesive is cured.

Typical dwell time is 4 seconds at 250 °C.

A mildly-activated flux will eliminate the need for removal of corrosive residues in most applications.

Manual soldering

Fix the component by first soldering two diagonally-opposite end leads. Use a low voltage (24 V or less) soldering iron applied to the flat part of the lead. Contact time must be limited to 10 seconds at up to 300 °C.

When using a dedicated tool, all other leads can be soldered in one operation within 2 to 5 seconds between 270 and 320 °C.

6-bit analog-to-digital converter with multiplexer and clamp

TDA8706A

Suitability of surface mount IC packages for wave and reflow soldering methods

PACKAGE ⁽¹⁾	SOLDERING METHOD	
	WAVE	REFLOW ⁽²⁾
BGA, LBGA, LFBGA, SQFP, TFBGA, VFBGA	not suitable	suitable
DHVQFN, HBCC, HBGA, HLQFP, HSQFP, HSOP, HTQFP, HTSSOP, HVQFN, HVSON, SMS	not suitable ⁽³⁾	suitable
PLCC ⁽⁴⁾ , SO, SOJ	suitable	suitable
LQFP, QFP, TQFP	not recommended ⁽⁴⁾⁽⁵⁾	suitable
SSOP, TSSOP, VSO, VSSOP	not recommended ⁽⁶⁾	suitable

Notes

- For more detailed information on the BGA packages refer to the “(LF)BGA Application Note” (AN01026); order a copy from your Philips Semiconductors sales office.
- All surface mount (SMD) packages are moisture sensitive. Depending upon the moisture content, the maximum temperature (with respect to time) and body size of the package, there is a risk that internal or external package cracks may occur due to vaporization of the moisture in them (the so called popcorn effect). For details, refer to the Drypack information in the “Data Handbook IC26; Integrated Circuit Packages; Section: Packing Methods”.
- These packages are not suitable for wave soldering. On versions with the heatsink on the bottom side, the solder cannot penetrate between the printed-circuit board and the heatsink. On versions with the heatsink on the top side, the solder might be deposited on the heatsink surface.
- If wave soldering is considered, then the package must be placed at a 45° angle to the solder wave direction. The package footprint must incorporate solder thieves downstream and at the side corners.
- Wave soldering is suitable for LQFP, TQFP and QFP packages with a pitch (e) larger than 0.8 mm; it is definitely not suitable for packages with a pitch (e) equal to or smaller than 0.65 mm.
- Wave soldering is suitable for SSOP, TSSOP, VSO and VSSOP packages with a pitch (e) equal to or larger than 0.65 mm; it is definitely not suitable for packages with a pitch (e) equal to or smaller than 0.5 mm.

6-bit analog-to-digital converter with multiplexer and clamp

TDA8706A

DATA SHEET STATUS

LEVEL	DATA SHEET STATUS ⁽¹⁾	PRODUCT STATUS ⁽²⁾⁽³⁾	DEFINITION
I	Objective data	Development	This data sheet contains data from the objective specification for product development. Philips Semiconductors reserves the right to change the specification in any manner without notice.
II	Preliminary data	Qualification	This data sheet contains data from the preliminary specification. Supplementary data will be published at a later date. Philips Semiconductors reserves the right to change the specification without notice, in order to improve the design and supply the best possible product.
III	Product data	Production	This data sheet contains data from the product specification. Philips Semiconductors reserves the right to make changes at any time in order to improve the design, manufacturing and supply. Relevant changes will be communicated via a Customer Product/Process Change Notification (CPCN).

Notes

1. Please consult the most recently issued data sheet before initiating or completing a design.
2. The product status of the device(s) described in this data sheet may have changed since this data sheet was published. The latest information is available on the Internet at URL <http://www.semiconductors.philips.com>.
3. For data sheets describing multiple type numbers, the highest-level product status determines the data sheet status.

DEFINITIONS

Short-form specification — The data in a short-form specification is extracted from a full data sheet with the same type number and title. For detailed information see the relevant data sheet or data handbook.

Limiting values definition — Limiting values given are in accordance with the Absolute Maximum Rating System (IEC 60134). Stress above one or more of the limiting values may cause permanent damage to the device. These are stress ratings only and operation of the device at these or at any other conditions above those given in the Characteristics sections of the specification is not implied. Exposure to limiting values for extended periods may affect device reliability.

Application information — Applications that are described herein for any of these products are for illustrative purposes only. Philips Semiconductors make no representation or warranty that such applications will be suitable for the specified use without further testing or modification.

DISCLAIMERS

Life support applications — These products are not designed for use in life support appliances, devices, or systems where malfunction of these products can reasonably be expected to result in personal injury. Philips Semiconductors customers using or selling these products for use in such applications do so at their own risk and agree to fully indemnify Philips Semiconductors for any damages resulting from such application.

Right to make changes — Philips Semiconductors reserves the right to make changes in the products - including circuits, standard cells, and/or software - described or contained herein in order to improve design and/or performance. When the product is in full production (status 'Production'), relevant changes will be communicated via a Customer Product/Process Change Notification (CPCN). Philips Semiconductors assumes no responsibility or liability for the use of any of these products, conveys no licence or title under any patent, copyright, or mask work right to these products, and makes no representations or warranties that these products are free from patent, copyright, or mask work right infringement, unless otherwise specified.

Philips Semiconductors – a worldwide company

Contact information

For additional information please visit <http://www.semiconductors.philips.com>. Fax: +31 40 27 24825

For sales offices addresses send e-mail to: sales.addresses@www.semiconductors.philips.com.

© Koninklijke Philips Electronics N.V. 2003

SCA75

All rights are reserved. Reproduction in whole or in part is prohibited without the prior written consent of the copyright owner.

The information presented in this document does not form part of any quotation or contract, is believed to be accurate and reliable and may be changed without notice. No liability will be accepted by the publisher for any consequence of its use. Publication thereof does not convey nor imply any license under patent- or other industrial or intellectual property rights.

Printed in The Netherlands

753504/02/pp17

Date of release: 2003 Jul 21

Document order number: 9397 750 10878

Let's make things better.

**Philips
Semiconductors**



PHILIPS