

# DAC1627D1G25

Dual 16-bit DAC, LVDS interface, up to 1.25 Gsps, x2, x4 and x8 interpolating

Rev. 1 — 29 April 2011

Objective data sheet

## 1. General description

---

The DAC1627D1G25 is a high-speed 16-bit dual channel Digital-to-Analog Converter (DAC) with selectable  $\times 2$ ,  $\times 4$  and  $\times 8$  interpolating filters optimized for multi-carrier and broadband wireless transmitters at sample rates of up to 1.25 Gsps. Supplied from a 3.3 V and a 1.8 V source, the DAC1627D1G25 integrates a differential scalable output current up to 31.8 mA.

The DAC1627D1G25 is capable of meeting multi-carrier GSM specifications. For example, with an output frequency of 150 MHz and a DAC clock frequency of 1.22 Gsps the full-scale dynamic range is:

- $SFDR_{RBW} = 85 \text{ dBc}$  (bandwidth = 250 MHz)
- $IMD3 = 85 \text{ dBc}$

The Serial Peripheral Interface (SPI) provides full control of the DAC1627D1G25.

The DAC1627D1G25 integrates a Low Voltage Differential Signaling (LVDS) Double Data Rate (DDR) receiver interface, with an on-chip  $100 \Omega$  termination. The LVDS DDR interface accepts a multiplex input data stream such as interleaved or folded. An internal LVDS input auto-calibration ensures the robustness and stability of the interface.

Digital on-chip modulation converts the complex I and Q inputs from baseband to IF. The mixer frequency is set by a 40-bit Numerically Controlled Oscillator (NCO). High resolution internal gain, phase and offset control provide outstanding image and Local Oscillator (LO) signal rejection at the system analog modulator output.

An inverse  $(\sin x) / x$  function ensures a controlled flatness 0.5 dB for high bandwidths at the DAC output.

Multiple device synchronization allows synchronization of the outputs of multiple DAC devices. MDS guarantees a maximum skew of one output clock period between several devices.

The DAC1627D1G25 includes a very low noise capacitor-free integrated Phase-Locked Loop (PLL) multiplier which generates a DAC clock rate from the LVDS clock rate.

The DAC1627D1G25 is available in a HVQFN72 package (10 mm  $\times$  10 mm).



## 2. Features and benefits

- Dual 16-bit resolution
- 1.25 Gsps maximum update rate
- Selectable x2, x4 and x8 interpolating filters
- Very low noise capacitor-free integrated Phase-Locked Loop (PLL)
- Embedded Numerically Controlled Oscillator (NCO) with 40-bit programmable frequency
- Embedded complex modulator
- 1.8 V and 3.3 V power supplies
- LVDS DDR compatible input interface with on-chip 100 Ω terminations
- LVDS DDR input clock up to 312.5 MHz
- LVDS or LVPECL compatible DAC clock
- Interleaved or folded I and Q data input mode
- Synchronization of multiple DAC devices
- 3 or 4 wires mode SPI interface
- Differential scalable output current from 6.95 mA to 31.8 mA
- External analog offset control (10-bit auxiliary DACs)
- High resolution internal digital gain and offset control to support high performance IQ-modulator image rejection
- Internal phase correction
- Inverse (sin x) / x function
- Power-down mode and Sleep mode; 5-bit NCO low power mode
- On-chip 1.25 V reference
- Industrial temperature range -40 °C to +85 °C
- 72 pins small form factor HVQFN package

## 3. Applications

- Wireless infrastructure: MG\_GSM, LTE, WiMAX, GSM, CDMA, WCDMA, TD-SCDMA
- Communication: LMDS/MMDS, point-to-point
- Direct Digital Synthesis (DDS)
- Broadband wireless systems
- Digital radio links
- Instrumentation
- Automated Test Equipment (ATE)

## 4. Ordering information

Table 1. Ordering information

Type number	Package		Version
	Name	Description	
DAC1627D1G25	HVQFN72	plastic thermal enhanced very thin quad flat package; no leads; 72 terminals; body 10 × 10 × 0.85 mm	SOT813-3

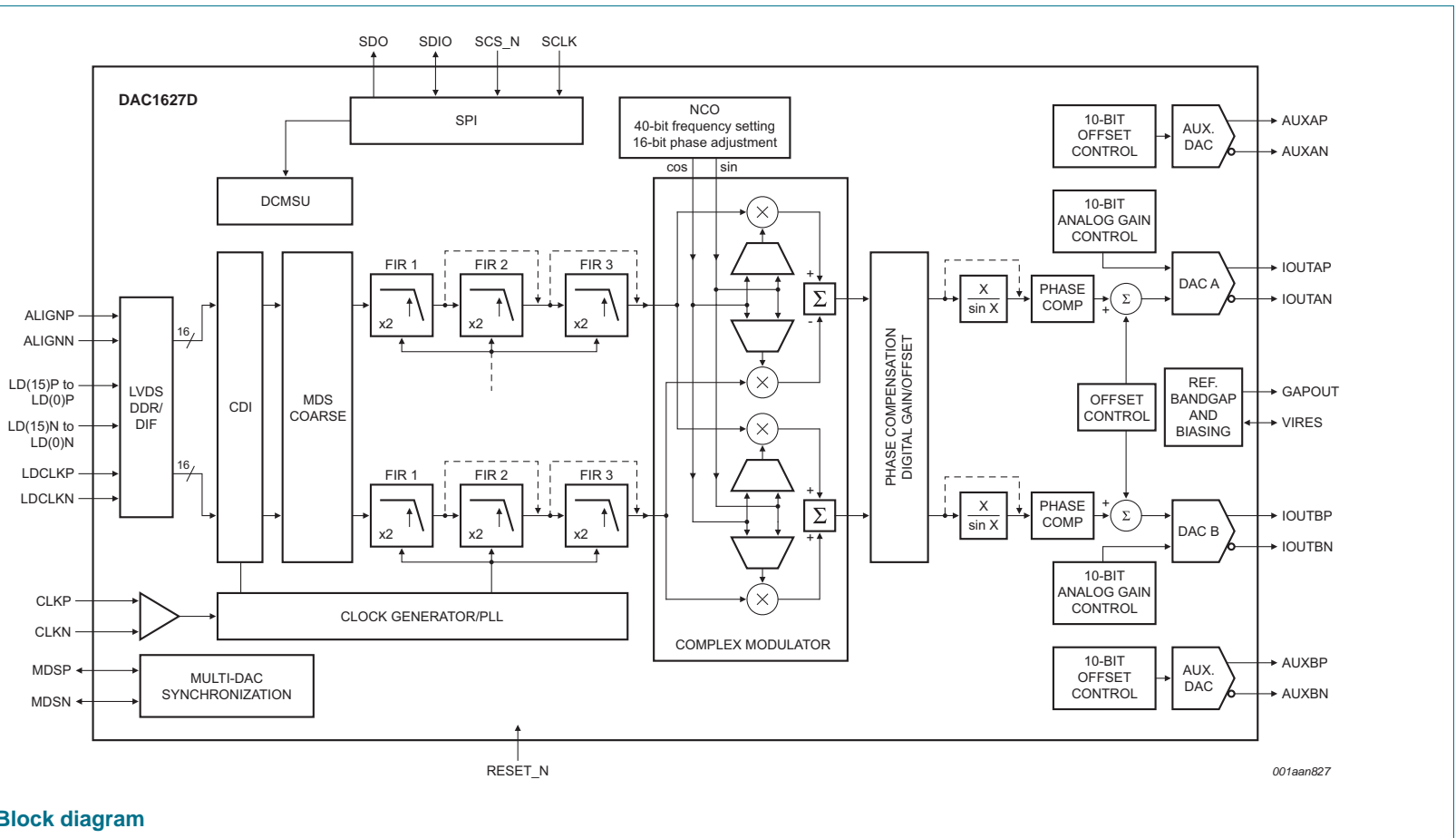

Fig 1. Block diagram

## 5. Block diagram

## 6. Pinning information

### 6.1 Pinning

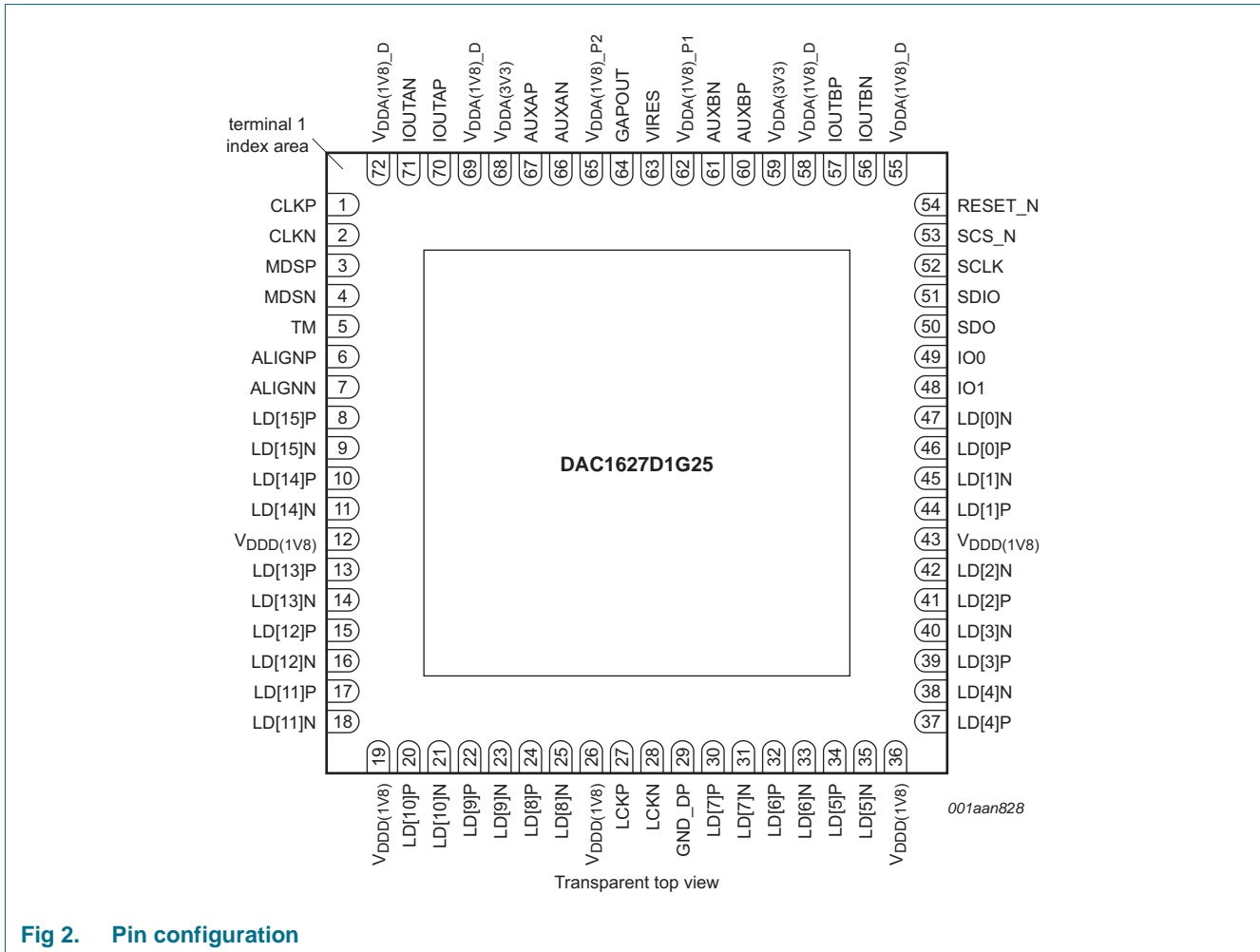

Fig 2. Pin configuration

### 6.2 Pin description

Table 2. Pin description

Symbol	Pin	Type <sup>[1]</sup>	Description
CLKP	1	I	DAC clock positive input
CLKN	2	I	DAC clock negative input
MDSP	3	IO	multi-device synchronization positive signal
MDSN	4	IO	multi-device synchronization negative signal
TM	5	I	Test mode selection (connect to GND)
ALIGNP	6	I	positive input for data alignment
ALIGNN	7	I	negative input for data tanglement
LD[15]P	8	I	LVDS positive input bit 15 <sup>[2]</sup>
LD[15]N	9	I	LVDS negative input bit 15 <sup>[2]</sup>

Table 2. Pin description ...continued

Symbol	Pin	Type <sup>[1]</sup>	Description
LD[14]P	10	I	LVDS positive input bit 14 <sup>[2]</sup>
LD[14]N	11	I	LVDS negative input bit 14 <sup>[2]</sup>
V <sub>DD(1V8)</sub>	12	P	1.8 V digital power supply
LD[13]P	13	I	LVDS positive input bit 13 <sup>[2]</sup>
LD[13]N	14	I	LVDS negative input bit 13 <sup>[2]</sup>
LD[12]P	15	I	LVDS positive input bit 12 <sup>[2]</sup>
LD[12]N	16	I	LVDS negative input bit 12 <sup>[2]</sup>
LD[11]P	17	I	LVDS positive input bit 11 <sup>[2]</sup>
LD[11]N	18	I	LVDS negative input bit 11 <sup>[2]</sup>
V <sub>DD(1V8)</sub>	19	P	1.8 V digital power supply
LD[10]P	20	I	LVDS positive input bit 10 <sup>[2]</sup>
LD[10]N	21	I	LVDS negative input bit 10 <sup>[2]</sup>
LD[9]P	22	I	LVDS positive input bit 9 <sup>[2]</sup>
LD[9]N	23	I	LVDS negative input bit 9 <sup>[2]</sup>
LD[8]P	24	I	LVDS positive input bit 8 <sup>[2]</sup>
LD[8]N	25	I	LVDS negative input bit 8 <sup>[2]</sup>
V <sub>DD(1V8)</sub>	26	P	1.8 V digital power supply
LCKP	27	I	LVDS positive data clock input
LCKN	28	I	LVDS negative data clock input
GND_DP	29	G	connect to ground
LD[7]P	30	I	LVDS positive input bit 7 <sup>[2]</sup>
LD[7]N	31	I	LVDS negative input bit 7 <sup>[2]</sup>
LD[6]P	32	I	LVDS positive input bit 6 <sup>[2]</sup>
LD[6]N	33	I	LVDS negative input bit 6 <sup>[2]</sup>
LD[5]P	34	I	LVDS positive input bit 5 <sup>[2]</sup>
LD[5]N	35	I	LVDS negative input bit 5 <sup>[2]</sup>
V <sub>DD(1V8)</sub>	36	P	1.8 V digital power supply
LD[4]P	37	I	LVDS positive input bit 4 <sup>[2]</sup>
LD[4]N	38	I	LVDS negative input bit 4 <sup>[2]</sup>
LD[3]P	39	I	LVDS positive input bit 3 <sup>[2]</sup>
LD[3]N	40	I	LVDS negative input bit 3 <sup>[2]</sup>
LD[2]P	41	I	LVDS positive input bit 2 <sup>[2]</sup>
LD[2]N	42	I	LVDS negative input bit 2 <sup>[2]</sup>
V <sub>DD(1V8)</sub>	43	P	1.8 V digital power supply
LD[1]P	44	I	LVDS positive input bit 1 <sup>[2]</sup>
LD[1]N	45	I	LVDS negative input bit 1 <sup>[2]</sup>
LD[0]P	46	I	LVDS positive input bit 0 <sup>[2]</sup>
LD[0]N	47	I	LVDS negative input bit 0 <sup>[2]</sup>
IO1	48	IO	IO port bit 1
IO0	49	IO	IO port bit 0
SDO	50	O	SPI data output

**Table 2.** Pin description ...continued

Symbol	Pin	Type <sup>[1]</sup>	Description
SDIO	51	IO	SPI data input/output
SCLK	52	I	SPI clock
SCS_N	53	I	SPI chip select (active LOW)
RESET_N	54	I	general reset (active LOW)
V <sub>DDA(1V8)_D</sub>	55	P	1.8 V analog power supply (DAC core)
IOUTBN	56	O	complementary DAC B output current
IOUTBP	57	O	DAC B output current
V <sub>DDA(1V8)_D</sub>	58	P	1.8 V analog power supply (DAC core)
V <sub>DDA(3V3)</sub>	59	P	3.3 V analog power supply
AUXBP	60	O	auxiliary DAC B output current
AUXBN	61	O	complementary auxiliary DAC B output current
V <sub>DDA(1V8)_P1</sub>	62	P	1.8 V analog power supply (PLL)
VIRES	63	IO	DAC biasing resistor
GAPOUT	64	IO	band gap input/output voltage
V <sub>DDA(1V8)_P2</sub>	65	P	1.8 V analog power supply (PLL)
AUXAN	66	O	complementary auxiliary DAC A output current
AUXAP	67	O	auxiliary DAC A output current
V <sub>DDA(3V3)</sub>	68	P	3.3 V analog power supply
V <sub>DDA1V8_D</sub>	69	P	1.8 V analog power supply (DAC core)
IOUTAP	70	O	DAC A output current
IOUTAN	71	O	complementary DAC A output current
V <sub>DDA(1V8)_D</sub>	72	P	1.8 V analog power supply (DAC core)
GND	H	G	ground (exposed die pad)

[1] P: power supply; G: ground; I: input; O: output.

[2] The LVDS input data bus order can be reversed and each element can be swapped between P and N using dedicated registers (see [Table 86](#), [Table 87](#) and [Table 88](#)).

## 7. Limiting values

**Table 3.** Limiting values

In accordance with the Absolute Maximum Rating System (IEC 60134).

Symbol	Parameter	Conditions	Min	Max	Unit
V <sub>DDA(3V3)</sub>	analog supply voltage (3.3 V)		-0.5	+4.6	V
V <sub>DDD(1V8)</sub>	digital supply voltage (1.8 V)		-0.5	+2.5	V
V <sub>DDA(1V8)</sub>	analog supply voltage (1.8 V)		<sup>[1]</sup> -0.5	+2.5	V
V <sub>I</sub>	input voltage	input pins referenced to GND	-0.5	<td>	V
V <sub>O</sub>	output voltage	pins IOUTAP, IOUTAN, IOUTBP, IOUTBN, AUXAP, AUXAN, AUXBP and AUXBN referenced to GND	-0.5	+4.6	V

**Table 3. Limiting values ...continued***In accordance with the Absolute Maximum Rating System (IEC 60134).*

Symbol	Parameter	Conditions	Min	Max	Unit
T <sub>stg</sub>	storage temperature		-55	+150	°C
T <sub>amb</sub>	ambient temperature		-40	+85	°C
T <sub>j</sub>	junction temperature		-40	+125	°C

[1] The analog 1.8 V power supply must be connected to pins VDDA1V8\_D, VDDA1V8\_P1, and VDDA1V8\_P2.

## 8. Thermal characteristics

**Table 4. Thermal characteristics**

Symbol	Parameter	Conditions	Typ	Unit
R <sub>th(j-a)</sub>	thermal resistance from junction to ambient		[1] 16.2	K/W
R <sub>th(j-c)</sub>	thermal resistance from junction to case		[1] 6.7	K/W

[1] Value for six layers board in still air with a minimum of 49 thermal vias.

## 9. Characteristics

**Table 5. Characteristics**

$V_{DDA(1V8)} = 1.8\text{ V}$ ;  $V_{DDD(1V8)} = 1.8\text{ V}$ ;  $V_{DDA(3V3)} = 3.3\text{ V}$ ; Typical values measured at  $T_{amb} = +25\text{ °C}$ ;  $R_L = 50\ \Omega$ ;  $I_{O(fs)} = 20\text{ mA}$ ; maximum sample rate used; external PLL; no auxiliary DAC; no inverse sinus x/x; no output correction; output load condition defined in [Figure 22](#); output level = 1 V (p-p).

Symbol	Parameter	Conditions	Test [1]	Min	Typ	Max	Unit
$V_{DDA(3V3)}$	analog supply voltage (3.3 V)		C	3.15	3.3	3.45	V
$V_{DDD(1V8)}$	digital supply voltage (1.8 V)		C	1.7	1.8	1.9	V
$V_{DDA(1V8)}$	analog supply voltage (1.8 V)		C	[2] 1.7	1.8	1.9	V
$I_{DDA(3V3)}$	analog supply current (3.3 V)	Aux DAC on	C	<td>	63	<td>	mA
$I_{DDD(1V8)}$	digital supply current (1.8 V)	$f_s = 983.04\text{ 67}$ ; x4 interpolation; no NCO; MDS on	C	<td>	520	<td>	mA
		$f_s = 620\text{ Msp/s}$ ; x2 interpolation; NCO on; no MDS	C	<td>	440	<td>	mA
$I_{DDA(1V8)}$	analog supply current (1.8 V)	$f_s = 983.04\text{ Msp/s}$ ; 1 V (p-p)	C	[2] <td>	210	<td>	mA
		$f_s = 620\text{ Msp/s}$ ; 1 V (p-p)	C	<td>	210	<td>	mA
$P_{tot}$	total power dissipation	$f_s = 1228.8\text{ Msp/s}$ ; x4 interpolation; NCO on; MDS off	C	-	1770	-	mW
		$f_s = 983.04\text{ Msp/s}$ ; x4 interpolation; 5-bit NCO; MDS off	C	-	1530	-	mW
		$f_s = 983.04\text{ Msp/s}$ ; x4 interpolation; NCO off; MDS off	C	-	<td>	-	mW
		$f_s = 737.28\text{ Msp/s}$ ; x4 interpolation; 5-bit NCO; MDS off	C	-	1540	-	mW
		$f_s = 620\text{ Msp/s}$ ; x2 interpolation; 40-bit NCO; MDS off		-	1400	-	mW
		full power-down	C	-	1.2	-	mW

### Clock inputs (pins CLKP, CLKN)

$V_{i(\text{clk})\text{dif}}$	differential clock input voltage	peak-to-peak	C	200	-	2000	mV
$R_i$	input resistance		D	-	<td>	-	MΩ
$C_i$	input capacitance		D	-	<td>	-	pF

### Digital inputs (pins LD[15]P to LD[0]P, LD[15]N to LD[0]N, LCKP and LCKN)

$V_i$	input voltage	$ V_{\text{gpd}}  < 50\text{ mV}$ [3]	C	825	-	1575	mV
$V_{\text{idth}}$	input differential threshold voltage	$ V_{\text{gpd}}  < 50\text{ mV}$ [3]	C	-100	-	+100	mV

**Table 5. Characteristics ...continued**

$V_{DDA(1V8)} = 1.8\text{ V}$ ;  $V_{DDD(1V8)} = 1.8\text{ V}$ ;  $V_{DDA(3V3)} = 3.3\text{ V}$ ; Typical values measured at  $T_{amb} = +25\text{ }^{\circ}\text{C}$ ;  $R_L = 50\text{ }\Omega$ ;  $I_{O(fs)} = 20\text{ mA}$ ; maximum sample rate used; external PLL; no auxiliary DAC; no inverse sinus x/x; no output correction; output load condition defined in [Figure 22](#); output level = 1 V (p-p).

Symbol	Parameter	Conditions	Test [1]	Min	Typ	Max	Unit
$R_i$	input resistance		D	-	100	-	$\Omega$
$C_i$	input capacitance		D	-	<td>	-	pF
<b>Digital inputs/outputs (pins MDSN, MDSP)</b>							
$V_{O(dif)(p-p)}$	peak-to-peak differential output voltage		C	-	600	-	mV
$C_{O(L)}$	output load capacitance	between GND and pin MDSN or MDSP	D	-	-	<td>	pF
$C_i$	input capacitance	between GND and pin MDSN or MDSP	D	-	<td>	-	pF
$R_i$	input resistance		D	-	100	-	$\Omega$
$V_i$	input voltage	$ V_{gpd}  < 50\text{ mV}$ [3]	C	825	-	1575	mV
$V_{idth}$	input differential threshold voltage	$ V_{gpd}  < 50\text{ mV}$ [3]	C	-100	-	+100	mV
<b>Digital inputs/outputs (pins SDO, SDIO, SCLK, SCS_N, RESET_N)</b>							
$V_{IL}$	LOW-level input voltage		C	GND	-	$0.3V_{DD(1V8)}$	V
$V_{IH}$	HIGH-level input voltage		C	$0.7V_{DD(1V8)}$	-	$V_{DD(1V8)}$	V
$V_{OL}$	LOW-level output voltage	pins SDO and SDIO	C	0	-	<td>	V
$V_{OH}$	HIGH-level output voltage	pins SDO and SDIO	C	<td>	-	$V_{DD(1V8)}$	V
$I_{IL}$	LOW-level input current	$V_{IL} = <td>\text{ V}$	I	-	<td>	-	$\mu\text{A}$
$I_{IH}$	HIGH-level input current	$V_{IH} = <td>\text{ V}$	I	-	<td>	-	$\mu\text{A}$
$C_i$	input capacitance		D	-	<td>	-	pF
<b>Analog outputs (pins IOUTAP, IOUTAN, IOUTBP, IOUTBN)</b>							
$I_{O(fs)}$	full-scale output current	controlled by the analog GAIN registers (see <a href="#">Table 46</a> to <a href="#">Table 49</a> )	D	6.19	-	31.8	mA
		default value	D	-	20	-	mA
$V_O$	output voltage	compliance range	D	<td>	-	$V_{DDA(3V3)}$	V
$V_{O(cm)}$	common-mode output voltage		D	-	2.8	-	V
$R_o$	output resistance		D	-	250	-	k $\Omega$
$C_o$	output capacitance		D	-	3	-	pF
$N_{DAC(mono)}$	DAC monotonicity	guaranteed	D	-	<td>	-	bits

**Table 5. Characteristics ...continued**

$V_{DDA(1V8)} = 1.8\text{ V}$ ;  $V_{DDD(1V8)} = 1.8\text{ V}$ ;  $V_{DDA(3V3)} = 3.3\text{ V}$ ; Typical values measured at  $T_{amb} = +25\text{ °C}$ ;  $R_L = 50\ \Omega$ ;  $I_{O(fs)} = 20\text{ mA}$ ; maximum sample rate used; external PLL; no auxiliary DAC; no inverse sinus x/x; no output correction; output load condition defined in [Figure 22](#); output level = 1 V (p-p).

Symbol	Parameter	Conditions	Test [1]	Min	Typ	Max	Unit
$\Delta E_O$	offset error variation		D	-	<tbd>	-	ppm/°C
$\Delta E_G$	gain error variation		D	-	<tbd>	-	ppm/°C
<b>Reference voltage output (pin GAPOUT)</b>							
$V_{O(ref)}$	reference output voltage	$T_{amb} = +25\text{ °C}$	I	<tbd>	1.25	<tbd>	V
$I_{O(ref)}$	reference output current	1.25 V external voltage	D	-	40	-	$\mu\text{A}$
$\Delta V_{O(ref)}$	reference output voltage variation		C	-	<tbd>	-	ppm/°C
<b>Analog auxiliary outputs (pins AUXAP, AUXAN, AUXBP and AUXBN)</b>							
$I_{O(fs)}$	full-scale output current	auxiliary DAC A; differential outputs	I	-	2.2	-	mA
		auxiliary DAC B; differential outputs	I	-	2.2	-	mA
$V_{O(aux)}$	auxiliary output voltage	compliance range	C	0	-	2	V
$N_{DAC(aux)mono}$	auxiliary DAC monotonicity	guaranteed	D	-	10	-	Bits
<b>LVDS input timing</b>							
$f_{data}$	data rate	input; x2 interpolation	C	<tbd>	-	312.5	MHz
		input; x4 interpolation	C	<tbd>	-	312.5	MHz
		input; x8 interpolation	C	<tbd>	-	156.25	MHz
$t_{sk(clk-D)}$	skew time from clock to data input		C	-<tbd>	-	+<tbd>	ps
<b>DAC output timing</b>							
$f_s$	sampling rate		C	-	-	1250	MspS
$t_s$	settling time	to $\pm 0.5\text{ LSB}$	D	-	20	-	ns
<b>Internal PLL timing</b>							
$f_s$	sampling rate		C	-	-	1000	MspS
<b>40-bit NCO frequency range; <math>f_s = 1000\text{ MspS}</math></b>							
$f_{NCO}$	NCO frequency	two's complement coding					
		reg value = 8000000000h	D	-	-500	-	MHz
		reg value = FFFFFFFFh	D	-	-0.9095	-	mHz
		reg value = 0000000000h	D	-	0	-	Hz
		reg value = 0000000001h	D	-	+0.9095	-	mHz
		reg value = 7FFFFFFFh	D	-	+499.99909	-	MHz
$f_{step}$	step frequency		D	-	0.9095	-	mHz

**Table 5. Characteristics ...continued**

$V_{DDA(1V8)} = 1.8\text{ V}$ ;  $V_{DDD(1V8)} = 1.8\text{ V}$ ;  $V_{DDA(3V3)} = 3.3\text{ V}$ ; Typical values measured at  $T_{amb} = +25\text{ }^{\circ}\text{C}$ ;  $R_L = 50\text{ }\Omega$ ;  $I_{O(fs)} = 20\text{ mA}$ ; maximum sample rate used; external PLL; no auxiliary DAC; no inverse sinus x/x; no output correction; output load condition defined in [Figure 22](#); output level = 1 V (p-p).

Symbol	Parameter	Conditions	Test [1]	Min	Typ	Max	Unit
<b>Low power NCO frequency range; <math>f_s = 1000\text{ MHz}</math></b>							
$f_{\text{NCO}}$	NCO frequency	two's complement coding					
		reg value = F800000000h	D	-	-500	-	MHz
		reg value = F800000000h	D	-	-31.25	-	MHz
		reg value = 0000000000h	D	-	0	-	Hz
		reg value = 0800000000h	D	-	+31.25	-	MHz
		reg value = 7FFFFFFFh	D	-	+468.75	-	MHz
$f_{\text{step}}$	step frequency		D	-	31.25	-	MHz
<b>Dynamic performance</b>							
SFDR	spurious-free dynamic range	$f_{\text{data}} = 307.2\text{ MHz}$ ; $f_s = 1228.8\text{ Msps}$ ; $\text{BW} = f_s / 2$					
		$f_o = 20\text{ MHz}$ at -1 dBFS;	I	-	83	-	dBc
		$f_{\text{data}} = 245.76\text{ MHz}$ ; $f_s = 983.04\text{ Msps}$ ; $\text{BW} = f_s / 2$					
		$f_o = 20\text{ MHz}$ at -1 dBFS	I	-	85	-	dBc
SFDR <sub>RBW</sub>	restricted bandwidth spurious-free dynamic range	$f_{\text{data}} = 245.76\text{ MHz}$ ; $f_s = 983.04\text{ Msps}$ ; $f_o = 150\text{ MHz}$					
		BW = 100 MHz	I	-	90	-	dBc
		BW = 180 MHz	I	-	<td>	-	dBc
		$f_{\text{data}} = 307.2\text{ MHz}$ ; $f_s = 1228.8\text{ Msps}$ ; $f_o = 210\text{ MHz}$					
		BW = 100 MHz	I	-	<td>	-	dBc
		BW = 180 MHz	I	-	<td>	-	dBc
IMD3	third-order intermodulation distortion	$f_{\text{data}} = 245.76\text{ MHz}$ ; $f_s = 983.04\text{ Msps}$ ; $f_{o1} = 20\text{ MHz}$ ; $f_{o2} = 21\text{ MHz}$ ; x4 interpolation; output level = -1 dBFS	I	-	93	-	dBc
		$f_{\text{data}} = 245.76\text{ MHz}$ ; $f_s = 983.04\text{ Msps}$ ; $f_{o1} = 152\text{ MHz}$ ; $f_{o2} = 155.1\text{ MHz}$ ; $f_s = 1228.8\text{ MHz}$ ; x4 interpolation; output level = -1 dBFS	I	-	85	-	dBc

**Table 5. Characteristics ...continued**

$V_{DDA(1V8)} = 1.8\text{ V}$ ;  $V_{DDD(1V8)} = 1.8\text{ V}$ ;  $V_{DDA(3V3)} = 3.3\text{ V}$ ; Typical values measured at  $T_{amb} = +25\text{ }^{\circ}\text{C}$ ;  $R_L = 50\text{ }\Omega$ ;  $I_{O(fs)} = 20\text{ mA}$ ; maximum sample rate used; external PLL; no auxiliary DAC; no inverse sinus x/x; no output correction; output load condition defined in [Figure 22](#); output level = 1 V (p-p).

Symbol	Parameter	Conditions	Test [1]	Min	Typ	Max	Unit	
ACPR	adjacent channel power ratio	$f_s = 1228.8\text{ Msps}$ ; x4 interpolation; $f_o = 210\text{ MHz}$	1 carrier; BW = 5 MHz	D	-	77	-	dBc
			2 carriers; BW = 10 MHz	D	-	73	-	dBc
			4 carriers; BW = 20 MHz	D	-	72	-	dBc
			NSD	noise spectral density	$f_s = 983.04\text{ Msps}$ ; x4 interpolation; $f_o = 20\text{ MHz}$ at -1 dBFS	D	-	-164
		$f_s = 983.04\text{ Msps}$ ; x4 interpolation; $f_o = 153.6\text{ MHz}$ at -1 dBFS	D	-	-161	-	dBm/Hz	

- [1] D = guaranteed by design; C = guaranteed by characterization; I = 100 % industrially tested.
- [2]  $V_{DDA(1V8)_D}$ ,  $V_{DDA(1V8)_P1}$  and  $V_{DDA(1V8)_P2}$  must be connected to the same 1.8 V analog power supply. It is recommended to use dedicated filters for the three power pins.
- [3]  $|V_{gpd}|$  represents the ground potential difference voltage. This voltage is the result of current flowing through the finite resistance and the inductance between the receiver and the driver circuit ground voltages.

## 10. Application information

### 10.1 General description

The DAC1627D1G25 is a dual 16-bit DAC operating up to 1250 Msps. Each DAC consists of a segmented architecture, comprising a 6-bit thermometer sub-DAC and a 10-bit binary weighted sub-DAC.

A maximum input LVDS DDR data rate of up to 312.5 MHz and a maximum output sampling rate of 1250 Msps ensure more flexibility for wide bandwidth and multi-carrier systems. The internal 40-bit NCO of the DAC1627D1G25 simplifies the frequency selection of the system. The DAC1627D1G25 provides x2, x4 or x8 interpolation filters that are very useful for removing the undesired images.

Each DAC generates two complementary current outputs on pins IOUTAP and IOUTAN and pins IOUTBP and IOUTBN. These outputs provide a full-scale output current ( $I_{O(fs)}$ ) of up to 31.8 mA. An internal reference is available for the reference current which is externally adjustable using pin VIRES.

High resolution internal gain, phase and offset control provide outstanding image and Local Oscillator (LO) signal rejection at the system analog modulator output.

Multiple device synchronization enables synchronization of the outputs of multiple DAC devices. MDS guarantees a maximum skew of one output clock period between several devices.

All functions can be set using an SPI interface.

10.2 Serial Peripheral Interface (SPI)

10.2.1 Protocol description

The DAC1627D1G25 serial interface is a synchronous serial communication port ensures easy interface with many industry microprocessors. It provides access to the registers that define the operating modes of the chip in both write and read mode.

This interface can be configured as a 3-wire type (pin SDIO as bidirectional pin) or 4-wire type (pins SDIO and SDO as unidirectional pins, input and output port respectively). In both configurations, SCLK acts as the serial clock and SCS\_N as the serial chip select.

Figure 3 shows the SPI protocol. Each read/write operation is followed by an SCS\_N signal and enabled by a LOW assertion to drive the chip with two to five bytes, depending on the content of the instruction byte (see Table 7).

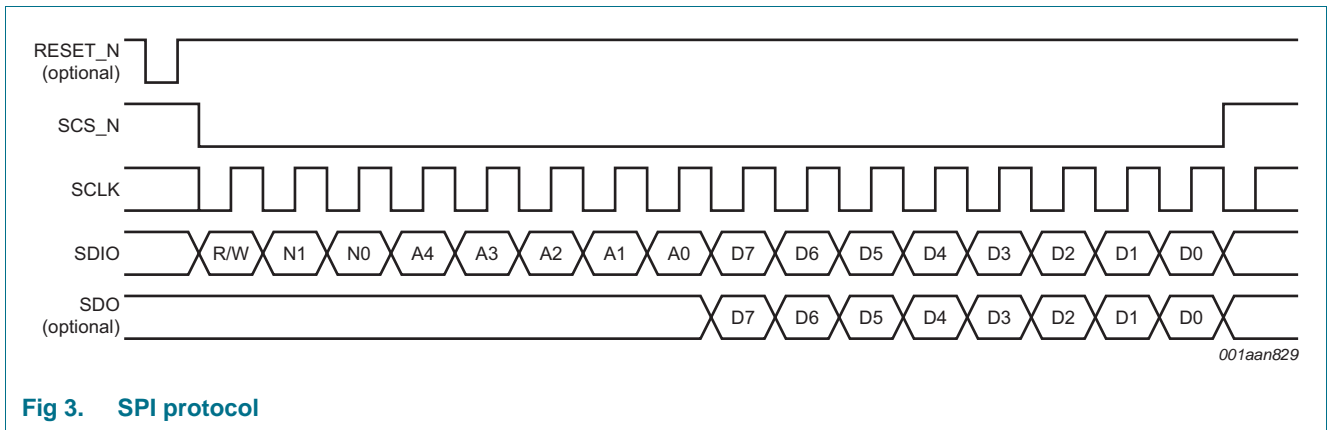

Fig 3. SPI protocol

R/W indicates the mode access (see Table 6)

Table 6. Read or Write mode access description

R/W	Description
0	Write mode operation
1	Read mode operation

Table 7 shows the number of bytes to be transferred. N1 and N0 indicate the number of bytes transferred after the instruction byte.

Table 7. Number of bytes to be transferred

N1	N0	Number of bytes transferred
0	0	1 byte
0	1	2 bytes
1	0	3 bytes
1	1	4 bytes

A[4:0] indicates which register is being addressed. If a multiple transfer occurs, this address concerns the first register. Next are those which follow directly in a decreasing order (see Table 23, Table 55 and Table 79).

The DAC1627D1G25 incorporates more than the 32 SPI registers allowed by the address value A[4:0]. It uses three SPI register pages (page\_00, page\_01, and page\_0A), each containing 32 registers. The 32<sup>nd</sup> register of each page indicates which page is currently addressed (00h, 01h or 0Ah).

**10.2.2 SPI timing description**

The SPI interface can operate at a frequency up to 15 MHz. The SPI timings are shown in [Figure 4](#).

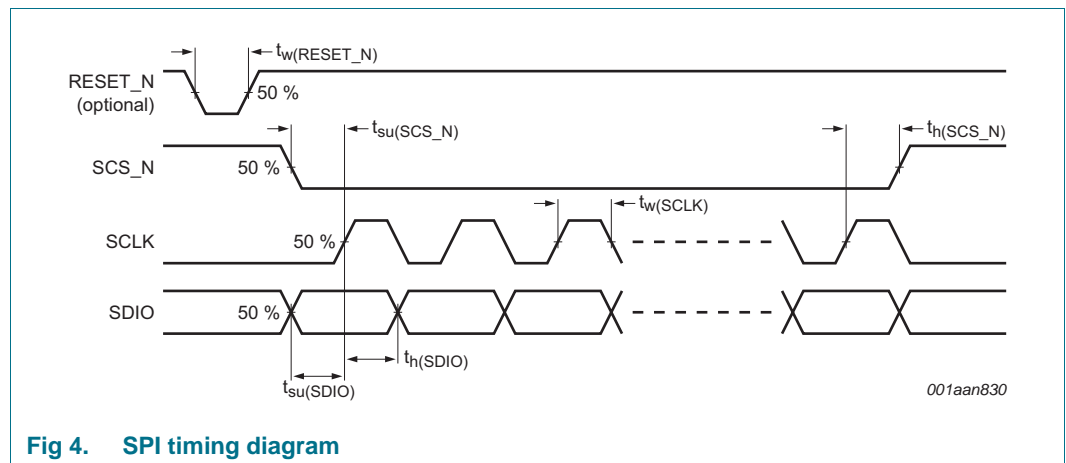

**Fig 4. SPI timing diagram**

The SPI timing characteristics are given in [Table 8](#).

**Table 8. SPI timing characteristics**

Symbol	Parameter	Min	Typ	Max	Unit
$f_{\text{SCLK}}$	SCLK frequency	-	-	25	MHz
$t_w(\text{SCLK})$	SCLK pulse width	30	-	-	ns
$t_{su}(\text{SCS\_N})$	SCS_N set-up time	20	-	-	ns
$t_h(\text{SCS\_N})$	SCS_N hold time	20	-	-	ns
$t_{su}(\text{SDIO})$	SDIO set-up time	10	-	-	ns
$t_h(\text{SDIO})$	SDIO hold time	5	-	-	ns
$t_w(\text{RESET\_N})$	RESET_N pulse width	30	-	-	ns

**10.3 Power-on sequence**

There are three steps for the power-on sequence (see [Figure 5](#)):

1. The board is power-on. At the turn-on time, all DAC1627D1G25 supplies have reached their specification ranges.
2. At least 1  $\mu\text{s}$  after the turn-on time pin RESET\_N must be released.

- When the DAC clock and LVDS clock are stable, the SPI configuration is sent to the DAC1627D1G25. Writing 0 in bits RST\_DCLK and RST\_LCLK of the register MAIN\_CNTRL (see [Table 80](#)) starts the automatic calibration. 30 μs after this calibration, the DAC1627D1G25 is operational.

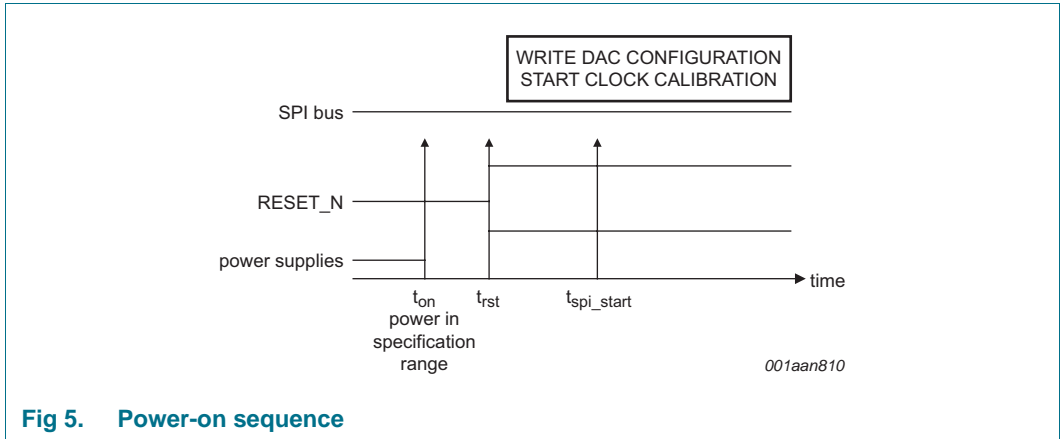

Fig 5. Power-on sequence

### 10.4 LVDS Data Input Format (DIF) block

The Data Input Formatting (DIF) block captures and resynchronizes data on the LVDS bus with its own LCLKP/LCLKN clock. Each LVDS input buffer has an internal resistance of 100 Ω, so an external resistor is not required. The DIF block includes two sub-blocks:

- LDVS receiver:**  
Provides high flexibility for the LVDS interface, especially for the PCB layout and the control of the input port polarity and the input port mapping.
- Data format block:**  
Enables the adaptation, which ensures the support of several data encoding modes.

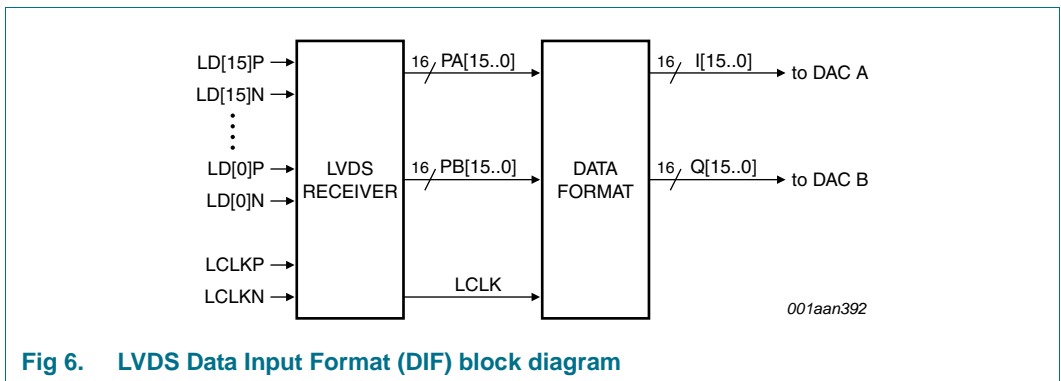

Fig 6. LVDS Data Input Format (DIF) block diagram

#### 10.4.1 Input port polarity

The polarity of each individual LVDS input (LD[15]P to LD[0]P and LD[15]N to LD[0]N) can be changed, ensuring a much easier PCB layout design. The input polarity is controlled with bits LD\_POL[7:0] in register LD\_POL\_LSB (see [Table 86](#)) and bits LD\_POL[15:8] in register LD\_POL\_MSB (see [Table 87](#)).

10.4.2 Input port mapping

Inverting the order of the LSB and the MSB of the LVDS bus using bit WORD\_SWAP in register LD\_CNTRL (see Table 88) also simplifies the design of the PCB (see Table 9).

Table 9. Input LVDS bus swapping

Internal LVDS bus	External LVDS bus (WORD_SWAP = 0)	External LVDS bus (WORD_SWAP = 1)
LDI[15]P,N	LD[15]P,N	LD[0]P,N
LDI[14]P,N	LD[14]P,N	LD[1]P,N
LDI[13]P,N	LD[13]P,N	LD[2]P,N
LDI[12]P,N	LD[12]P,N	LD[3]P,N
LDI[11]P,N	LD[11]P,N	LD[4]P,N
LDI[10]P,N	LD[10]P,N	LD[5]P,N
LDI[9]P,N	LD[9]P,N	LD[6]P,N
LDI[8]P,N	LD[8]P,N	LD[7]P,N
LDI[7]P,N	LD[7]P,N	LD[8]P,N
LDI[6]P,N	LD[6]P,N	LD[9]P,N
LDI[5]P,N	LD[5]P,N	LD[10]P,N
LDI[4]P,N	LD[4]P,N	LD[11]P,N
LDI[3]P,N	LD[3]P,N	LD[12]P,N
LDI[2]P,N	LD[2]P,N	LD[13]P,N
LDI[1]P,N	LD[1]P,N	LD[14]P,N
LDI[0]P,N	LD[0]P,N	LD[15]P,N

10.4.3 Input port swapping

The LVDS DDR receiver block internally maps the incoming LVDS data bus into two buses with a single data rate (Figure 7).

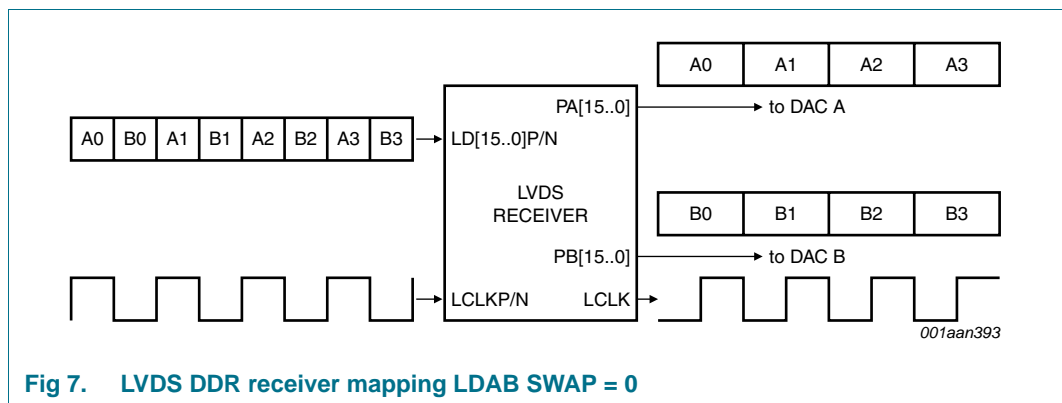

Fig 7. LVDS DDR receiver mapping LDAB SWAP = 0

These two buses can be swapped internally using bit LDAB\_SWAP of register LD\_CNTRL (see Table 88 and Figure 8).

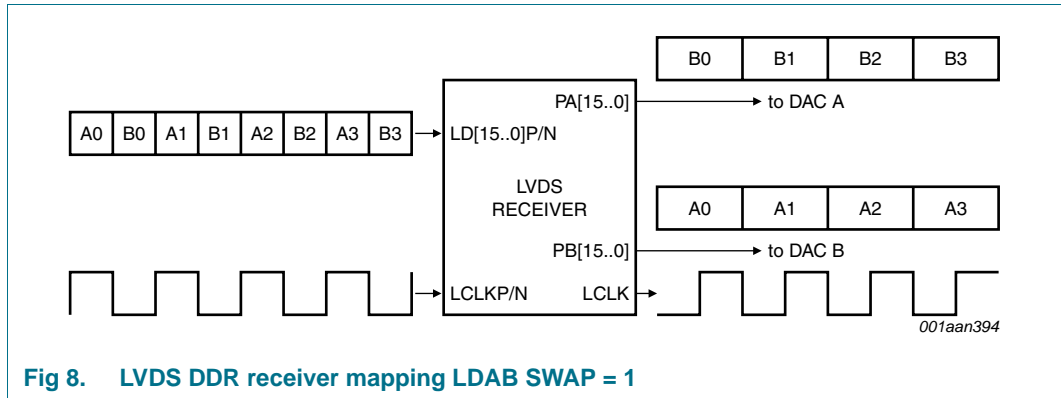

Fig 8. LVDS DDR receiver mapping LDAB SWAP = 1

10.4.4 Input port formatting

The LVDS DDR input bus multiplexes two 16-bit streams. The LVDS receiver block demultiplexes these two streams.

The two streams can carry two data formats:

- Folded
- Interleaved

The data format block is in charge of the data format adaptation (see [Figure 9](#)).

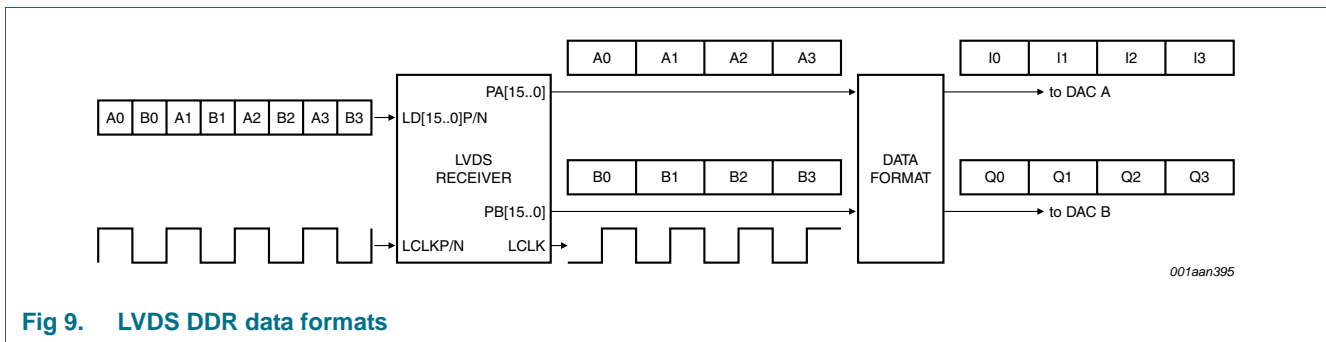

Fig 9. LVDS DDR data formats

The DAC1627D1G25 can correctly decode the input stream using bit IQ\_FORMAT of register LD\_CNTRL (see [Table 88](#)), because it can determine which format is used on the LVDS DDR bus.

[Table 10](#) shows the format mapping between the LVDS input data and the data sent to the two DAC channels depending on the data format selected.

Table 10. Folded and interleaved format mapping

Data format	Data bit mapping
interleaved format (IQ_FORMAT = 1)	In[15..0] = An[15..0]; Qn[15..0] = Bn[15..0]
folded format (IQ_FORMAT = 0)	In[15..8] = An[15..8]; In[7..0] = Bn[15..8] Qn[15..8] = An[7..0]; Qn[7..0] = Bn[7..0]

10.5 Input clock

The DAC1627D1G25 operates with two clocks, one for the LVDS DDR interface and one for the DAC core.

10.5.1 LVDS DDR clock

The LVDS DDR clock can be interfaced as shown in Figure 10 because the clock buffer contains a 100 Ω internal resistor.

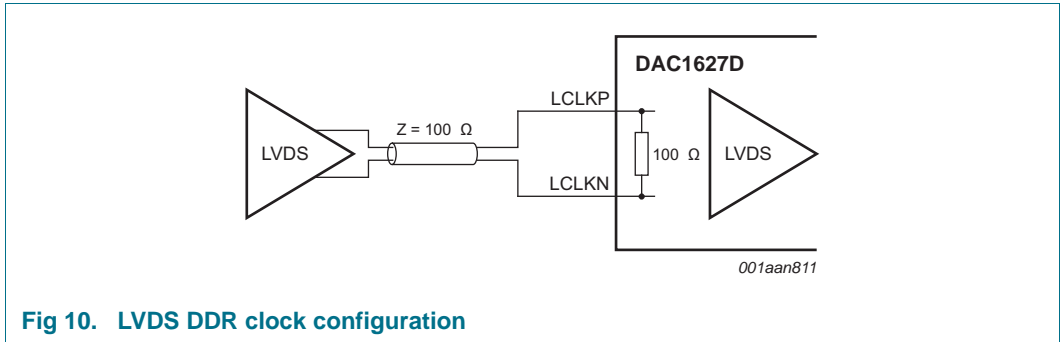

Fig 10. LVDS DDR clock configuration

10.5.2 DAC core clock

The DAC core clock can achieve a frequency of up to 1.25 Gsps. It includes internal biasing to support both AC-coupling and DC-coupling. The clock can be easily connected to any LVDS, CML or PECL clock sources.

Depending on the interface selected, the hardware configuration varies (see Figure 11 to Figure 13).

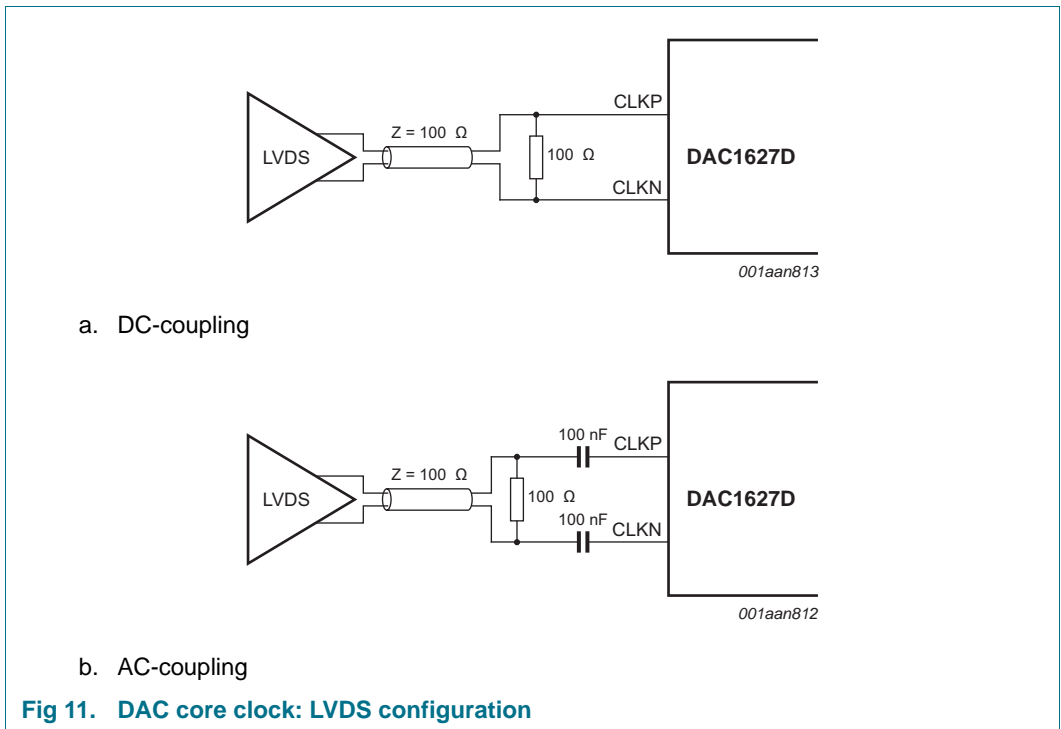

Fig 11. DAC core clock: LVDS configuration

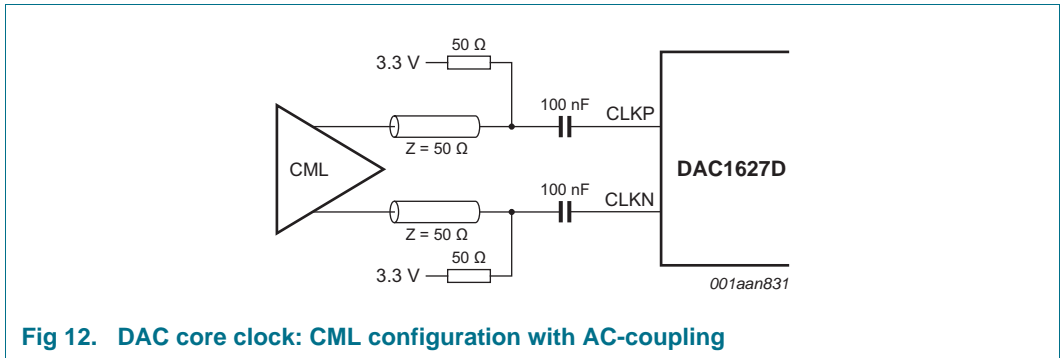

Fig 12. DAC core clock: CML configuration with AC-coupling

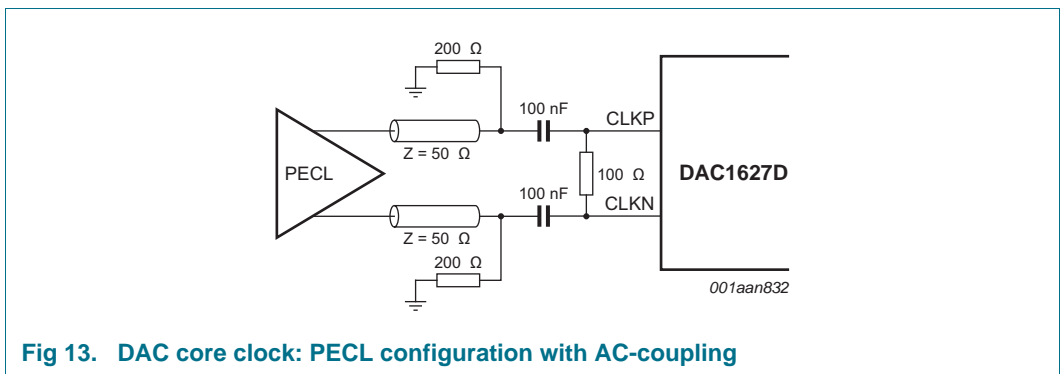

Fig 13. DAC core clock: PECL configuration with AC-coupling

### 10.6 Timing

The DAC1627D1G25 can operate at an update rate ( $f_s$ ) of up to 1.25 Gsps and with an input data rate ( $f_{data}$ ) of up to 312.5 MHz.

The sampling position of the LVDS data can be tuned using a 16-step compensation delay clock. The delay clock (see [Figure 14](#), signals LDCLKPcp and LDCLKNcp) is used internally to obtain a control signal, which enables calibrating the compensation delay at start-up and monitoring if the sampling position is properly aligned.

[Figure 14](#) shows how the compensation delay helps to recover the LVDS DDR data on both the A and B paths.

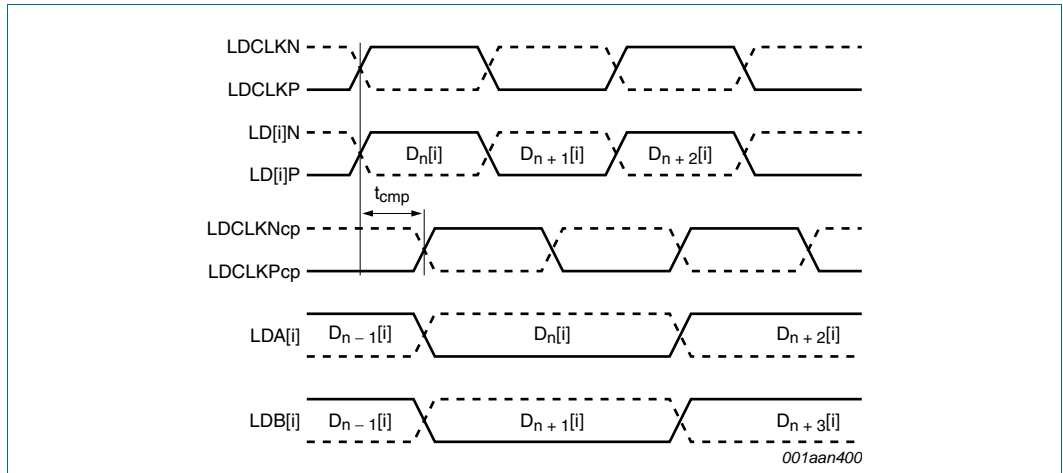

Fig 14. LVDS DDR demux timing (LVDS A and B paths not swapped; LDAB\_SWAP = 0)

The compensation delay time, referred to as  $t_{cmp}$  in Figure 14, can be tuned automatically or manually.

Automatic tuning is recommended for a high-speed LVDS data rate (> 300 MHz). The external LVDS data and clock signals aligns the rising and falling edges. The timing requirement is defined in Figure 15 and in Table 5.

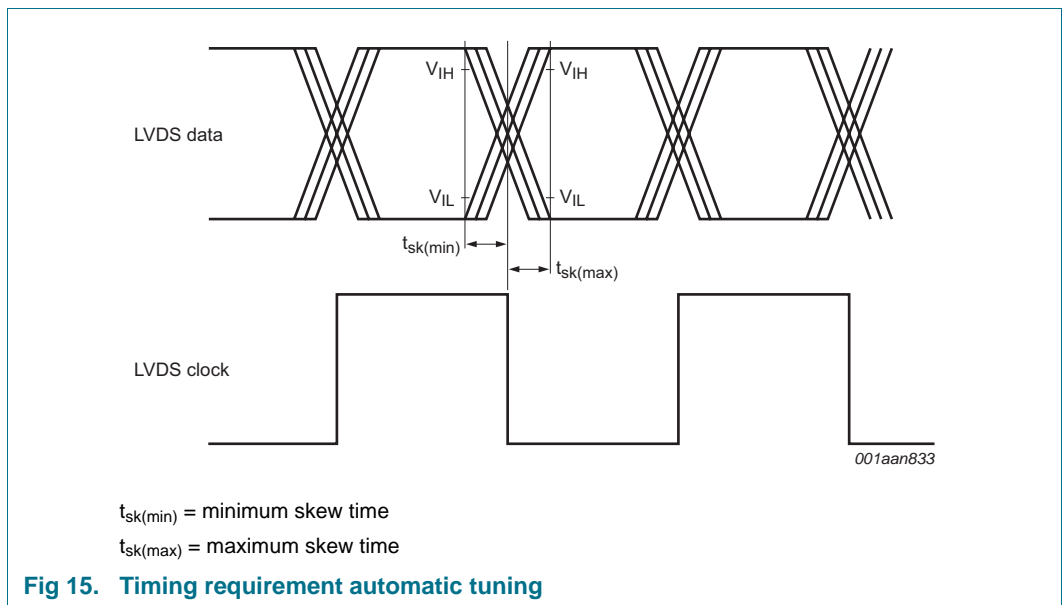

Fig 15. Timing requirement automatic tuning

When tuning manually, the compensation delay time ( $t_{cmp}$  in Figure 14), can be tuned as shown in Table 11 using bits LDCLK\_DEL[3:0] of register MAN\_LDCLKDEL (see Table 81) and bit CAL\_CNTRL of register MAIN\_CNTRL (see Table 80).

Table 11. Compensation delay values for manual tuning

LDCLK_DEL[3:0]	CAL_CNTRL	Typical compensation delay time
xxx	0	$t_{\text{cmp}}$ controlled by DCSMU block (automatic control)
0000	1	360 ps to 405 ps
0001	1	435 ps to 540 ps
0010	1	525 ps to 645 ps
0011	1	600 ps to 720 ps
0100	1	690 ps to 825 ps
0101	1	780 ps to 900 ps
0110	1	885 ps to 1035 ps
0111	1	960 ps to 1200 ps
1000	1	1260 ps to 1980 ps
1001	1	1350 ps to 2160 ps
1010	1	1440 ps to 2340 ps
1011	1	1512 ps to 2556 ps
1100	1	1566 ps to 2754 ps
1101	1	1620 ps to 2952 ps
1110	1	1674 ps to 3060 ps
1111	1	1710 ps to 3186 ps

## 10.7 Operating modes

The DAC1627D1G25 requires two differential clocks:

- The LVDS clock (LDCLKP, LDCLKN) for the LVDS DDR interface
- The data clock (CLKP, CLKN) for the internal PLL and the dual DAC core

The Clock Domain Interface (CDI) and the PLL have to be set correctly to configure the DAC1627D1G25 for an application mode. The default application is a  $\times 2$  upsampling mode (see [Section 10.7.1](#)). The CDI can also support  $\times 4$  and  $\times 8$  upsampling modes (see [Section 10.7.2](#) and [Section 10.7.3](#)).

## 10.7.1 CDI mode 0 (x2 interpolation)

CDI mode 0 (x2 interpolation) is required when the value of the LVDS DDR clock is twice the internal maximum CDI frequency. [Table 12](#) shows examples of applications using an internal PLL or an external clock for the DAC core.

**Table 12. CDI mode 0: operating modes examples**

LVDS DDR rate (MHz)	I rate; Q rate (Msps)	CDI mode <sup>[1]</sup>	FIR mode <sup>[2]</sup>	SSBM rate <sup>[3]</sup> (Msps)	DAC rate (Msps)	PLL configuration		
						DAC input clock <sup>[4]</sup> (MHz)	PLL status <sup>[5]</sup>	PLL divider <sup>[6]</sup>
320	320	0	x2	640	640	320	enabled	2
320	320	0	x2	640	640	640	disabled	n.a.

[1] Bits CDI\_MODE[1:0] of register MISC\_CNTRL (see [Table 89](#)).

[2] Bits INTERPOLATION[1:0] of register TXCFG (see [Table 25](#)).

[3] If a Single Sideband Modulator (SSBM) is used, see bits NCO\_ON and MODULATION[2:0] of register TXCFG (see [Table 25](#)).

[4] Pins CLKP and CLKN (see [Figure 2](#)).

[5] Bit PLL\_PD of register PLLCFG (see [Table 26](#)).

[6] Bits PLL\_DIV[1:0] of register PLLCFG (see [Table 26](#)).

## 10.7.2 CDI mode 1 (x4 interpolation)

CDI mode 1 (x4 interpolation) is required when the values of the LVDS DDR clock and the internal CDI frequency are equal. [Table 13](#) shows examples of applications using an internal PLL or an external clock for the DAC core.

**Table 13. CDI mode 1: operating modes examples**

LVDS DDR rate (MHz)	I rate; Q rate (Msps)	CDI mode <sup>[1]</sup>	FIR mode <sup>[2]</sup>	SSBM rate <sup>[3]</sup> (Msps)	DAC rate (Msps)	PLL configuration		
						DAC input clock <sup>[4]</sup> (MHz)	PLL status <sup>[5]</sup>	PLL divider <sup>[6]</sup>
250	250	1	x4	1000	1000	250	enabled	4
250	250	1	x4	1000	1000	1000	disabled	n.a.

[1] Bits CDI\_MODE[1:0] of register MISC\_CNTRL (see [Table 89](#)).

[2] Bits INTERPOLATION[1:0] of register TXCFG (see [Table 25](#)).

[3] If SSBM is used, see bits NCO\_ON and MODULATION[2:0] of register TXCFG (see [Table 25](#)).

[4] Pins CLKP and CLKN (see [Figure 2](#)).

[5] Bit PLL\_PD of register PLLCFG (see [Table 26](#)).

[6] Bits PLL\_DIV[1:0] of register PLLCFG (see [Table 26](#)).

10.7.3 CDI mode 2 (x8 interpolation)

CDI mode 2 (x8 interpolation) is required when the LVDS DDR clock is half the maximum CDI frequency or less. Table 14 shows examples of applications using an internal PLL or an external clock for the DAC core.

Table 14. CDI mode 2: operating modes examples

LVDS DDR rate (MHz)	I rate; Q rate (Msps)	CDI mode <sup>[1]</sup>	FIR mode <sup>[2]</sup>	SSBM rate <sup>[3]</sup> (Msps)	DAC rate (Msps)	PLL configuration		
						DAC input clock <sup>[4]</sup> (MHz)	PLL status <sup>[5]</sup>	PLL divider <sup>[6]</sup>
125	125	2	x8	1000	1000	125	enabled	4
125	125	2	x8	1000	1000	1000	disabled	n.a.

- [1] Bits CDI\_MODE[1:0] of register MISC\_CNTRL (see Table 89).
- [2] Bits INTERPOLATION[1:0] of register TXCFG (see Table 25).
- [3] If SSBM is used, see bits NCO\_ON and MODULATION[2:0] of register TXCFG (see Table 25).
- [4] Pins CLKP and CLKN (see Figure 2).
- [5] Bit PLL\_PD of register PLLCFG (see Table 26).
- [6] Bits PLL\_DIV[1:0] of register PLLCFG (see Table 26).

10.8 FIR filters

The DAC1627D1G25 integrates three selectable Finite Impulse Response (FIR) filters which enable the use of the device with x2, x4 or x8 interpolation rates. All three interpolation FIR filters have a stop-band attenuation of at least 80 dBc and a pass-band ripple of less than 0.0005 dB. Table 15 shows the coefficients of the interpolation filters.

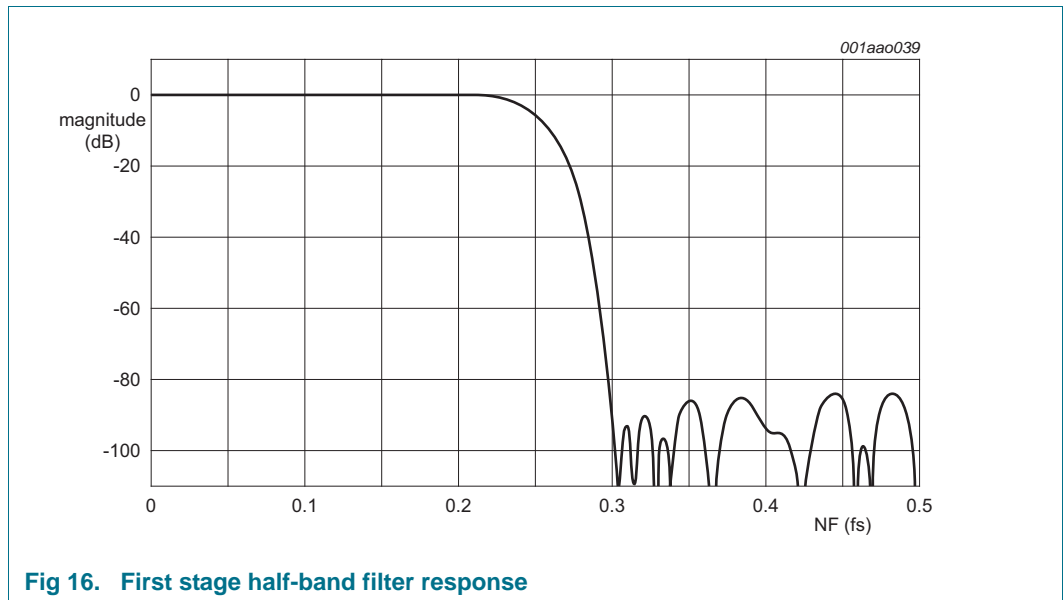

Fig 16. First stage half-band filter response

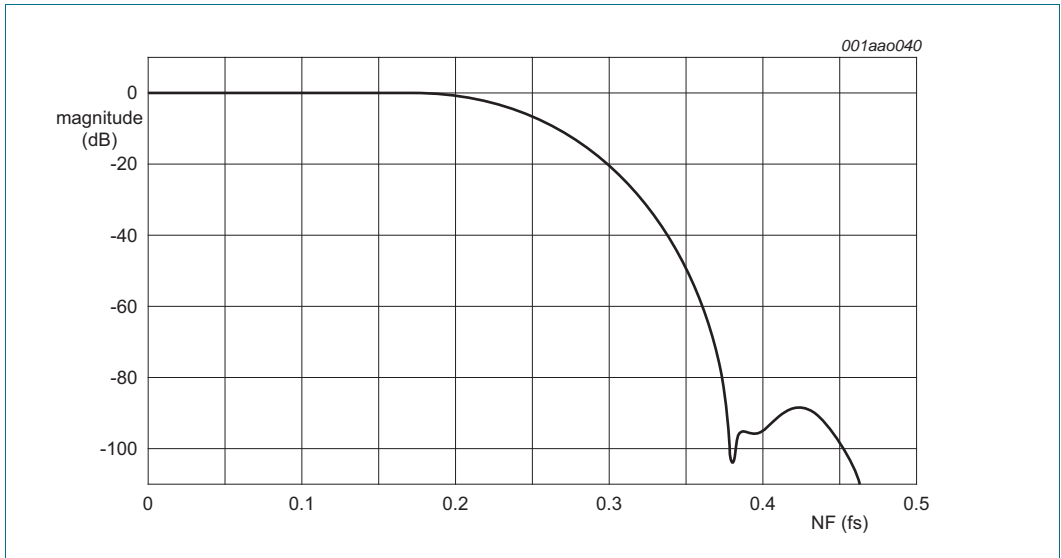

Fig 17. Second stage half-band filter response

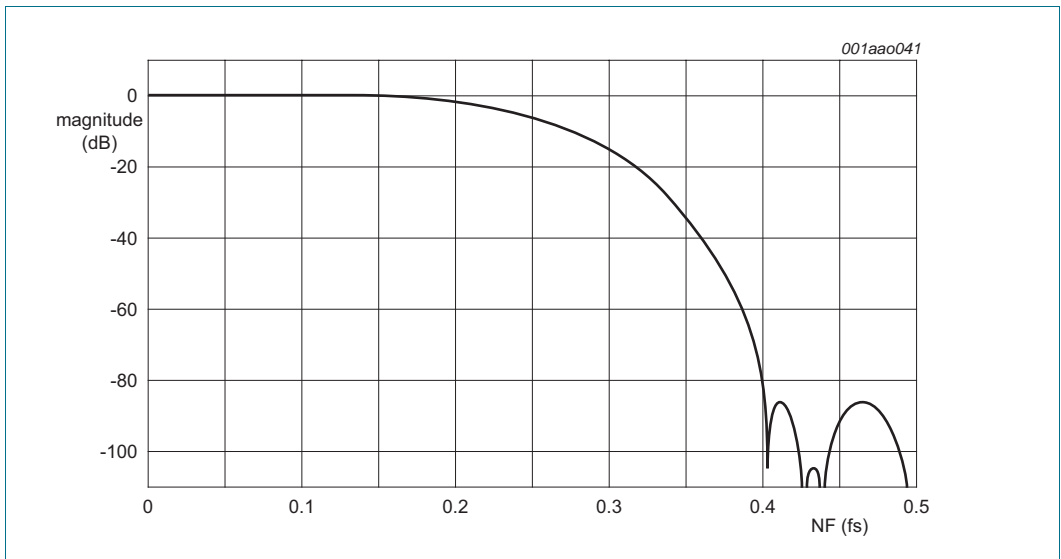

Fig 18. Third stage half-band filter response

Table 15: Interpolation filter coefficients

First interpolation filter			Second interpolation filter			Third interpolation filter		
Lower	Upper	Value	Lower	Upper	Value	Lower	Upper	Value
H(14)	-	65536	H(6)	-	32768	H(4)	-	1024
H(13)	H(15)	41501	H(5)	H(7)	20272	H(3)	H(5)	615
H(12)	H(16)	-13258	H(4)	H(8)	-5358	H(2)	H(6)	-127
H(11)	H(17)	7302	H(3)	H(9)	1986	H(1)	H(7)	27
H(10)	H(18)	-4580	H(2)	H(10)	-654	H(0)	H(8)	-3
H(9)	H(19)	2987	H(1)	H(11)	159	-	-	-
H(8)	H(20)	-1951	H(0)	H(12)	-21	-	-	-
H(7)	H(21)	1250	-	-	-	-	-	-

Table 15: Interpolation filter coefficients ...continued

First interpolation filter			Second interpolation filter			Third interpolation filter		
Lower	Upper	Value	Lower	Upper	Value	Lower	Upper	Value
H(6)	H(22)	-773	-	-	-	-	-	-
H(5)	H(23)	456	-	-	-	-	-	-
H(4)	H(24)	-252	-	-	-	-	-	-
H(3)	H(25)	128	-	-	-	-	-	-
H(2)	H(26)	-58	-	-	-	-	-	-
H(1)	H(27)	22	-	-	-	-	-	-
H(0)	H(28)	-6	-	-	-	-	-	-

### 10.9 Single SideBand Modulator (SSBM)

The SSBM is a quadrature modulator that enables mixing the I data and Q data with the sine and cosine signals generated by the NCO to generate path A and path B (see [Figure 19](#)).

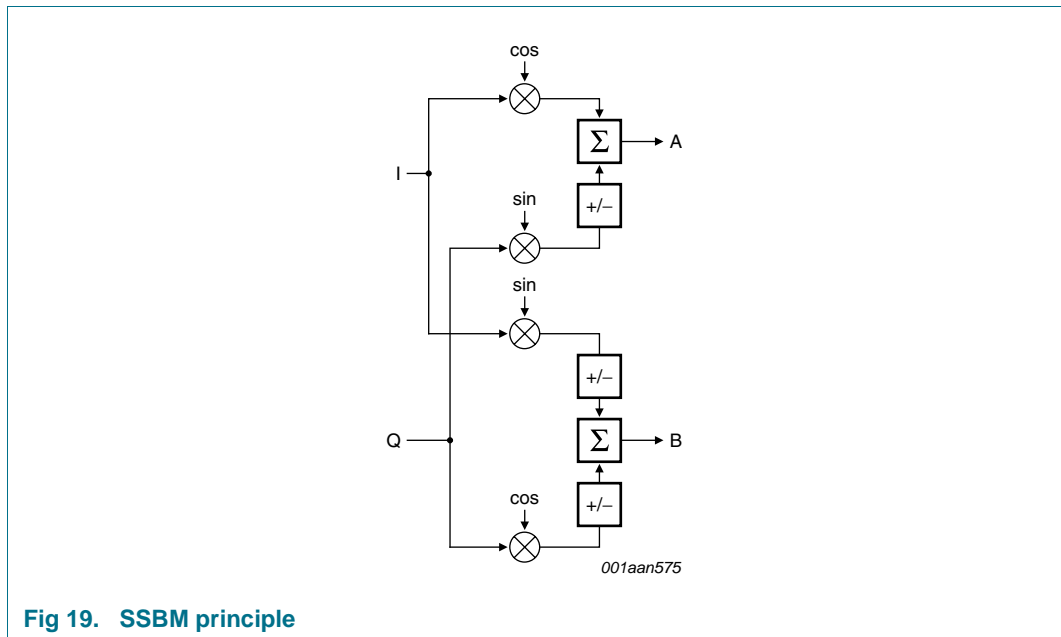

Fig 19. SSBM principle

The frequency of the NCO is programmed over 40 bits. NCO enables inverting the sine component to operate a positive or negative, lower or upper SSB upconversion (see register TXCFG in [Table 25](#)).

#### 10.9.1 NCO in 40 bits

When using NCO, the frequency can be set over 40 bits by five registers, FREQNCO\_B0 to FREQNCO\_B4 (see [Table 27](#) to [Table 31](#)).

The frequency is calculated with [Equation 1](#).

$$f_{NCO} = \frac{M \times f_s}{2^{40}} \tag{1}$$

Where:

- M is the two's complement coding representation of `FREQ_NCO[40:0]`
- $f_s$  is the DAC clock sampling frequency

The default settings are:

- $f_{NCO} = 96$  MHz
- $f_s = 640$  Msps

The phase of the NCO can be set by registers `PHINCO_LSB` and `PHINCO_MSB` over 16 bits from 0 to 360° (see [Table 44](#) and [Table 45](#)).

### 10.9.2 NCO low power

When using NCO low power (bit `NCO_LP_SEL`; see [Table 25](#)), the frequency can be set by the five MSB-bits of register `FREQNCO_B4` (bits `FREQ_NCO[39:35]`; see [Table 31](#)).

The frequency is calculated with [Equation 2](#).

$$f_{NCO} = \frac{M \times f_s}{2^5} \tag{2}$$

Where:

- M is the two's complement coding representation of `FREQ_NCO[39:35]`
- $f_s$  is the DAC clock sampling frequency

The phase of the NCO low power can be set by the five MSB-bits of register `PHINCO_MSB` (see [Table 45](#)).

### 10.9.3 Complex modulator

The complex modulator upconverts the single side band by mixing NCO signals and I and Q input signals. [Table 16](#) shows the various possibilities set by bits `MODULATION[2:0]` of register `TXCFG` (see [Table 25](#)).

**Table 16. Complex modulator operation mode**

MODULATION[2:0]	Mode	Path A	Path B
000	bypass	$I(t)$	$Q(t)$
001	positive upper ssb	$I(t) \times \cos(\omega_{NCO} \times t) - Q(t) \times \sin(\omega_{NCO} \times t)$	$I(t) \times \sin(\omega_{NCO} \times t) + Q(t) \times \cos(\omega_{NCO} \times t)$
010	positive lower ssb	$I(t) \times \cos(\omega_{NCO} \times t) + Q(t) \times \sin(\omega_{NCO} \times t)$	$I(t) \times \sin(\omega_{NCO} \times t) - Q(t) \times \cos(\omega_{NCO} \times t)$
011	negative upper ssb	$I(t) \times \cos(\omega_{NCO} \times t) - Q(t) \times \sin(\omega_{NCO} \times t)$	$-I(t) \times \sin(\omega_{NCO} \times t) - Q(t) \times \cos(\omega_{NCO} \times t)$
100	negative lower ssb	$I(t) \times \cos(\omega_{NCO} \times t) + Q(t) \times \sin(\omega_{NCO} \times t)$	$-I(t) \times \sin(\omega_{NCO} \times t) + Q(t) \times \cos(\omega_{NCO} \times t)$
others	not defined	-	-

10.9.4 Minus 3dB

In normal use, a full-scale pattern is also full-scale at the DAC output. Nevertheless, when the I data and Q data come close to full-scale simultaneously, some clipping can occur. The Minus 3dB function (bit MINUS\_3DB of register DAC\_OUT\_CTRL; see Table 38) can be used to reduce the 3 dB gain in the modulator. It retains a full-scale range at the DAC output without added interferers.

10.10 Inverse sinx / x

A selectable FIR filter is incorporated to compensate the sinx / x effect caused by the roll-off effect of the DAC. This filter introduces a loss of 3.4 dB at DC. The coefficients are represented in Table 17.

Table 17. Inversion filter coefficients

First interpolation filter		
Lower	Upper	Value
H(1)	H(9)	+1
H(2)	H(8)	-4
H(3)	H(7)	+13
H(4)	H(6)	-51
H(5)	-	+610

10.11 DAC transfer function

The full-scale output current for each DAC is the sum of the two complementary current outputs:

- $I_{OA(fs)} = I_{IOUTAP} + I_{IOUTAN}$
- $I_{OB(fs)} = I_{IOUTBP} + I_{IOUTBN}$

The output current of DAC A depends on the digital input data and the gain factor defined by bits DAC\_A\_DGAIN[7:0] of register DAC\_A\_DGAIN\_LSB (see Table 34) and bits DAC\_A\_DGAIN[11:8] of register DAC\_A\_DGAIN\_MSB (see Table 35).

$$I_{IOUTAP} = I_{OA(fs)} \times \frac{(DACADGAIN)}{1024} \times \left( \frac{DATA}{((65535))} \right) \tag{3}$$

$$I_{IOUTAN} = I_{OA(fs)} \times \left( 1 - \frac{(DACADGAIN)}{1024} \times \left( \frac{DATA}{((65535))} \right) \right) \tag{4}$$

The output current of DAC B depends on the digital input data and the gain factor defined by bits DAC\_B\_DGAIN[7:0] of register DAC\_B\_DGAIN\_LSB (see Table 36) and bits DAC\_B\_DGAIN[11:8] of register DAC\_B\_DGAIN\_MSB (see Table 37).

$$I_{IOUTBP} = I_{OB(fs)} \times \frac{(DACBDGAIN)}{1024} \times \left( \frac{DATA}{((65535))} \right) \tag{5}$$

$$I_{IOUTBN} = I_{OB(fs)} \times \left( 1 - \frac{(DACBDGAIN)}{1024} \times \left( \frac{DATA}{((65535))} \right) \right) \tag{6}$$

It is possible to define if the DAC1627D1G25 operates with a binary input or a two's complement input (bit CODING; see [Table 24](#)).

[Table 18](#) shows the output current as a function of the input data, when  $I_{OA(fs)} = I_{OB(fs)} = 20 \text{ mA}$ .

**Table 18. DAC transfer function**

Data	I15 to I0/Q15 to Q0 (binary coding)	I15 to I0/Q15 to Q0 (two's complement coding)	IOUTAP/IOUTBP	IOUTAN/IOUTBN
0	0000 0000 0000 0000	1000 0000 0000 0000	0 mA	20 mA
...	...	...	...	....
32768	1000 0000 0000 0000	0000 0000 0000 0000	10 mA	10 mA
...	...	...	...	...
65535	1111 1111 1111 1111	0111 1111 1111 1111	20 mA	0 mA

## 10.12 Full-scale current

### 10.12.1 Regulation

The DAC1627D1G25 reference circuitry integrates an internal band gap reference voltage which delivers a 1.25 V reference on the GAPOUT pin. It is recommended to decouple pin GAPOUT using a 100 nF capacitor.

The reference current is generated via an external resistor of 910 Ω (1 %) connected to VIRES and a control amplifier sets the appropriate full-scale current ( $I_{OA(fs)}$  and  $I_{OB(fs)}$ ) for both DACs (see [Figure 20](#)).

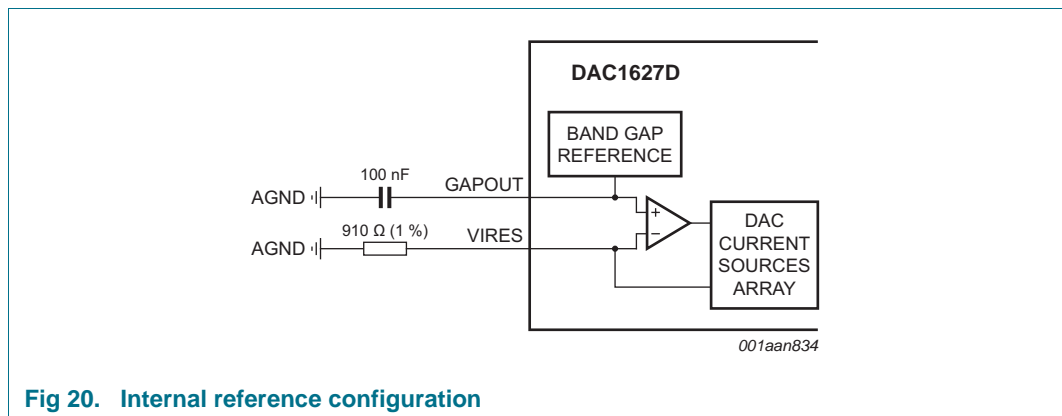

**Fig 20. Internal reference configuration**

[Figure 20](#) shows the optimal configuration for temperature drift compensation because the band gap reference voltage can be matched to the voltage across the feedback resistor.

The DAC current can also be adjusted by applying an external reference voltage to the non-inverting input pin GAPOUT and by disabling the internal band gap reference voltage (bit GAP\_PON of the COMMON register; see [Table 24](#)).

### 10.12.2 Full-scale current adjustment

The default full-scale current ( $I_{O(fs)}$ ) is 20 mA but further adjustments can be made by the user to both DACs independently via the serial interface from 6.95 mA to 28.7 mA,  $\pm 11 \%$ .

The settings applied to DAC\_A\_GAIN\_COARSE[3:0] (register 17h; see [Table 46](#) and register 18h see [Table 47](#);) and to DAC\_B\_GAIN\_COARSE[3:0] (register 19h; see [Table 48](#) and register 1Ah see [Table 49](#);) define the coarse variation of the full-scale current (see [Table 19](#)).

**Table 19.**  $I_{O(fs)}$  coarse adjustment

Default settings are shown highlighted.

DAC_GAIN_COARSE[3:0]		$I_{O(fs)}$ (mA)
Decimal	Binary	
0	0000	6.95
1	0001	8.4
2	0010	9.85
3	0011	11.3
4	0100	12.75
5	0101	14.2
6	0110	15.65
7	0111	17.1
8	1000	18.55
9	1001	20
10	1010	21.45
11	1011	22.9
12	1100	24.35
<b>13</b>	<b>1101</b>	<b>25.8</b>
14	1110	27.25
15	1111	28.7

The settings applied to DAC\_A\_GAIN\_FINE[5:0] (see register 17h in [Table 46](#)) and to DAC\_B\_GAIN\_FINE[5:0] (see register 19h in [Table 48](#)) define the fine variation of the full-scale current (see [Table 20](#)).

**Table 20.**  $I_{O(fs)}$  fine adjustment

Default settings are shown highlighted.

DAC_GAIN_FINE[5:0]		$\Delta I_{O(fs)}$ (%)
Decimal	Two's complement	
-32	10 0000	-11
...	...	...
<b>0</b>	<b>00 0000</b>	<b>0</b>
...	...	...
+31	01 1111	+11

## 10.13 Digital offset adjustment

The DAC1627D1G25 provides digital offset correction (bits DAC\_A\_OFFSET[7:0] in [Table 40](#) and bits DAC\_A\_OFFSET[15:8] in [Table 41](#) and register DAC\_B\_OFFSET[7:0] in [Table 42](#) and bits DAC\_B\_OFFSET[15:8] in [Table 43](#)) which can be used to adjust the common-mode level at the output of each DAC. It adds an offset at the end of the digital part, just before the DACs. [Table 21](#) shows the range of variation of the digital offset.

Table 21. Digital offset adjustment

DAC_A_OFFSET[15:0] DAC_B_OFFSET[15:0] (two's complement)	Offset applied
1000 0000 0000 0000	-32768
1000 0000 0000 0001	-32767
...	...
1111 1111 1111 1111	-1
0000 0000 0000 0000	0
0000 0000 0000 0001	+1
...	...
0111 1111 1111 1110	+32766
0111 1111 1111 1111	+32767

### 10.14 Analog output

The device has two output channels, producing two complementary current outputs, which enable the reduction of even-order harmonics and noise. The pins are IOUTAP/IOUTAN and IOUTBP/IOUTBN. They have to be connected via a load resistor  $R_L$  to the 3.3 V analog power supply ( $V_{DDA(3V3)}$ ).

Figure 21 shows the equivalent analog output circuit of one DAC. This circuit includes a parallel combination of NMOS current sources and associated switches for each segment.

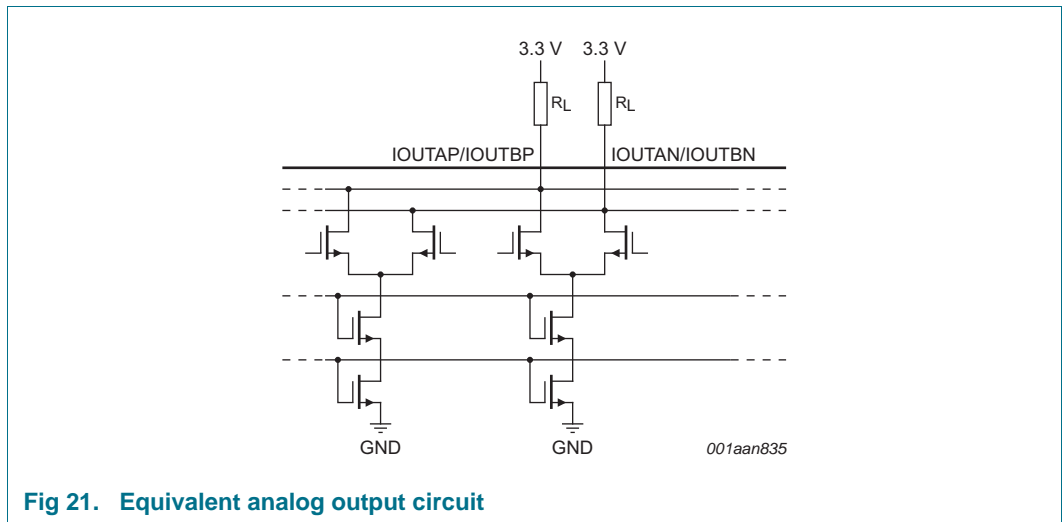

Fig 21. Equivalent analog output circuit

The cascode source configuration increases the output impedance of the source, which improves the dynamic performance of the DAC because there is less distortion.

Depending on the application, the various stages and the targeted performances, the device can be used for an output level of up to 2 V (p-p).

**10.15 Auxiliary DACs**

The DAC1627D1G25 integrates two auxiliary DACs, which are used to compensate any offset between the DACs and the next stage in the transmission path. Both auxiliary DACs have a 10-bit resolution and are current sources (referenced to ground).

The full-scale output current for each DAC is the sum of the two complementary current outputs:

- $I_{OAUXA(fs)} = I_{AUXAP} + I_{AUXAN}$
- $I_{OAUXB(fs)} = I_{AUXBP} + I_{AUXBN}$

The output current depends on the digital input data set by SPI registers DAC\_A\_Aux\_MSB (bits AUX\_A[9:2]; see [Table 50](#)), DAC\_A\_Aux\_LSB (bits AUX\_A[1:0]; see [Table 51](#)), DAC\_B\_Aux\_MSB (bits AUX\_B[9:2]; see [Table 52](#)) and DAC\_B\_Aux\_LSB (bits AUX\_B[1:0]; see [Table 53](#)).

$$I_{AUXAP} = I_{OAUXA(fs)} \times \left( \frac{DATAA}{1023} \right) \tag{7}$$

$$I_{AUXAN} = I_{OAUXA(fs)} \times \left( \frac{1023 - DATAA}{1023} \right) \tag{8}$$

$$I_{AUXBP} = I_{OAUXB(fs)} \times \left( \frac{DATAB}{1023} \right) \tag{9}$$

$$I_{AUXBN} = I_{OAUXB(fs)} \times \left( \frac{1023 - DATAB}{1023} \right) \tag{10}$$

[Table 22](#) shows the output current as a function of the auxiliary DACs data DATAA and DATAB above.

**Table 22. Auxiliary DAC transfer function**

DATAA; DATAB	AUX_A[9:2]/AUX_A[1:0]; AUX_B[9:0]/AUX_B[1:0] (binary coding)	$I_{AUXAP}$ ; $I_{AUXBP}$ (mA)	$I_{AUXAN}$ ; $I_{AUXBN}$ (mA)
0	00 0000 0000	0	2.2
...	...	...	...
512	10 0000 0000	1.1	1.1
...	...	...	...
1023	11 1111 1111	2.2	0

10.16 Output configuration

10.16.1 Basic output configuration

The use of a differentially coupled transformer output (see Figure 22) provides optimum distortion performance. In addition, it helps to match the impedance and provides electrical isolation.

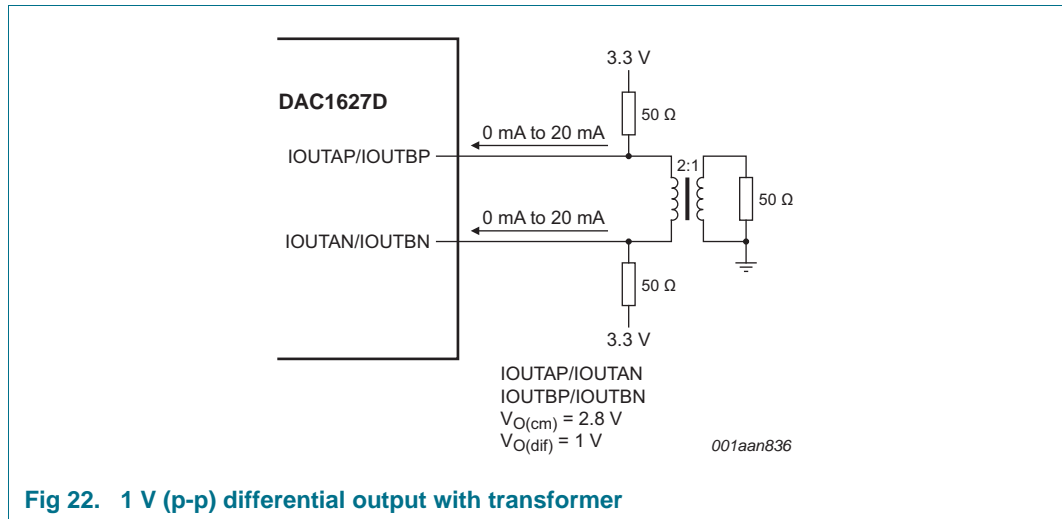

Fig 22. 1 V (p-p) differential output with transformer

The DAC1627D1G25 can operate a differential output of up to 2 V (p-p). In this configuration, it is recommended to connect the center tap of the transformer to a 62 Ω resistor, which is connected to the 3.3 V analog power supply. This adjusts the DC common-mode to around 2.7 V (see Figure 23).

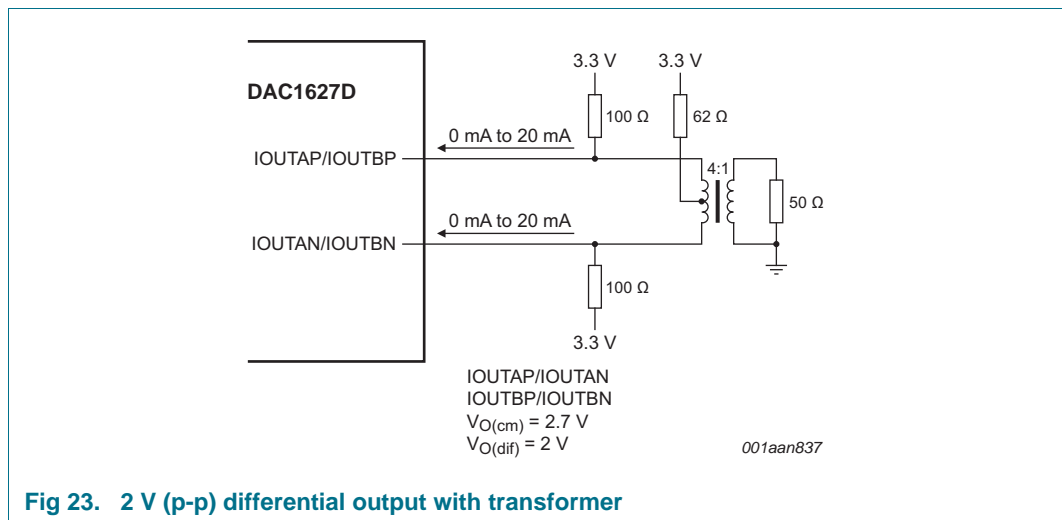

Fig 23. 2 V (p-p) differential output with transformer

10.16.2 IQ-modulator - BGX7100 interface

The DAC1627D1G25 can be easily connected to the BGX7100 NXP IQ-modulator. The offset compensation for local oscillator can be cancelled using the digital offset control in the device.

Figure 24 shows an example of a connection between the DAC1627D1G25 and the BGX7100 interface.

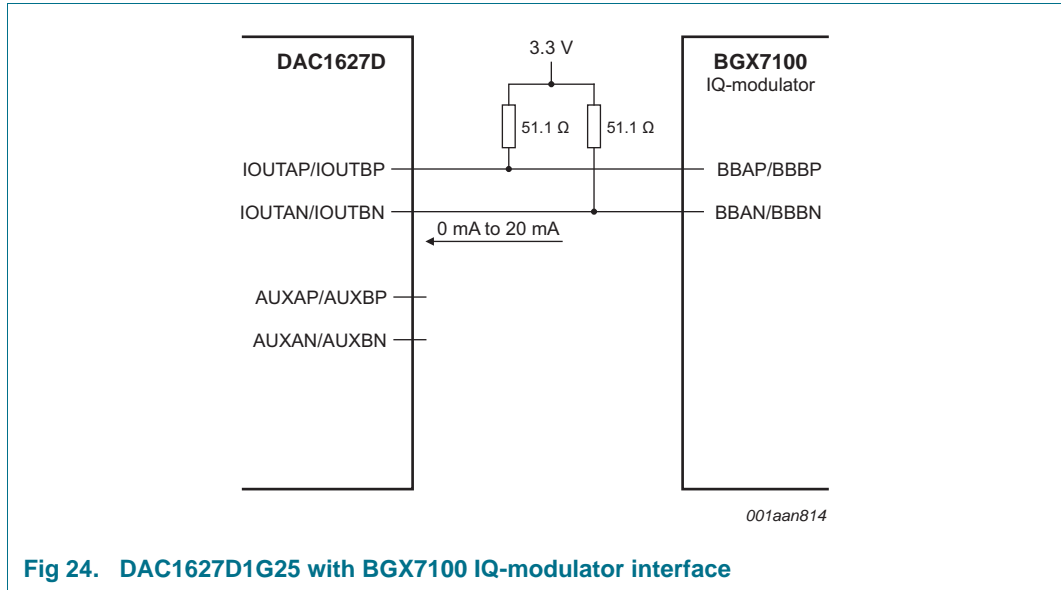

Fig 24. DAC1627D1G25 with BGX7100 IQ-modulator interface

10.16.3 IQ-modulator - DC interface

When the system operation requires to keep the DC component of the spectrum, the DAC1627D1G25 can use a DC interface to connect an IQ-modulator. In this case, the offset compensation for local oscillator can be cancelled using the digital offset control in the device.

Figure 25 shows an example of a connection to an IQ modulator with a 1.7 V common input level.

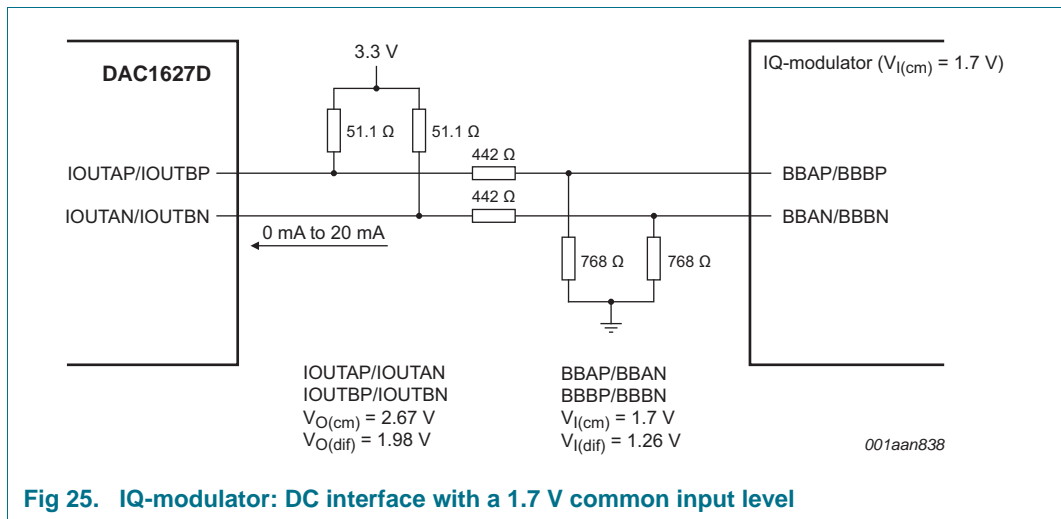
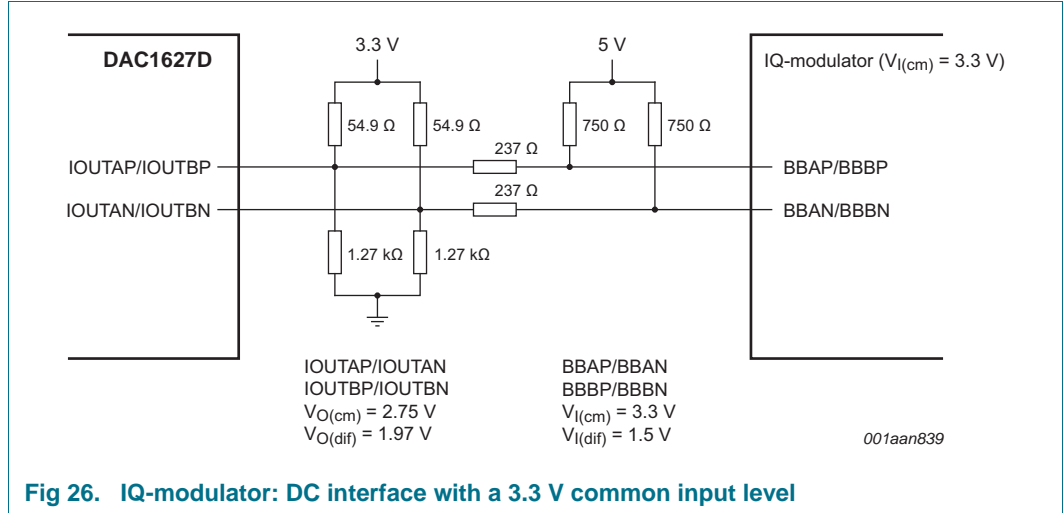

Fig 25. IQ-modulator: DC interface with a 1.7 V common input level

Figure 26 shows an example of a connection to an IQ-modulator with a 3.3 V common input level.



The auxiliary DACs can be used to control the offset within an accurate range or with accurate steps.

Figure 27 shows an example of a connection to an IQ-modulator with a 1.7 V common input level and auxiliary DACs.

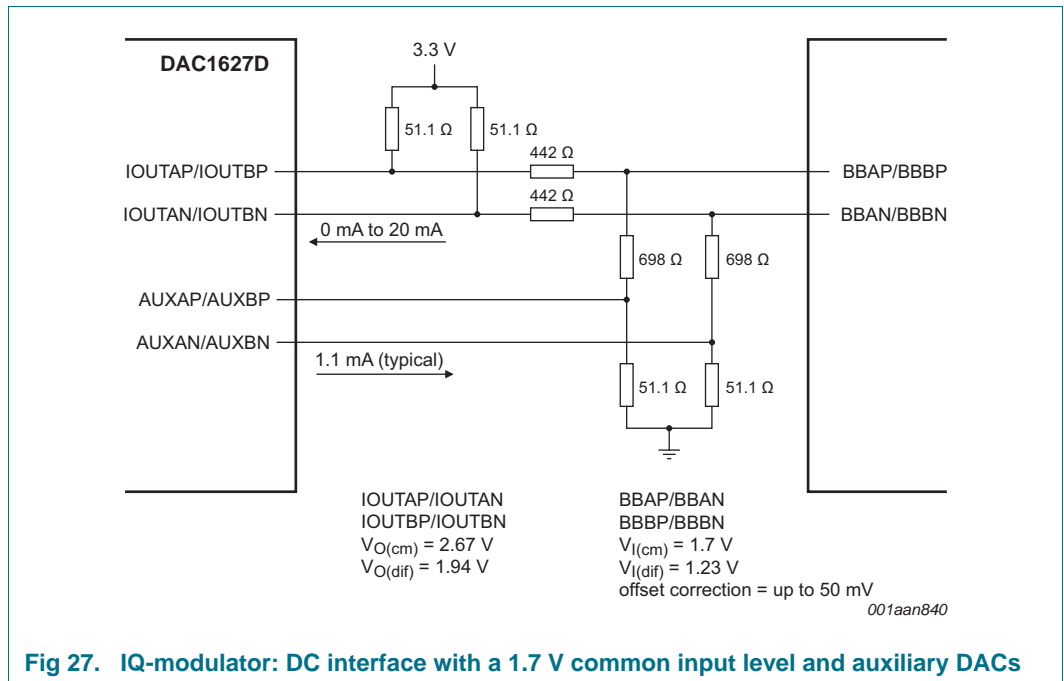
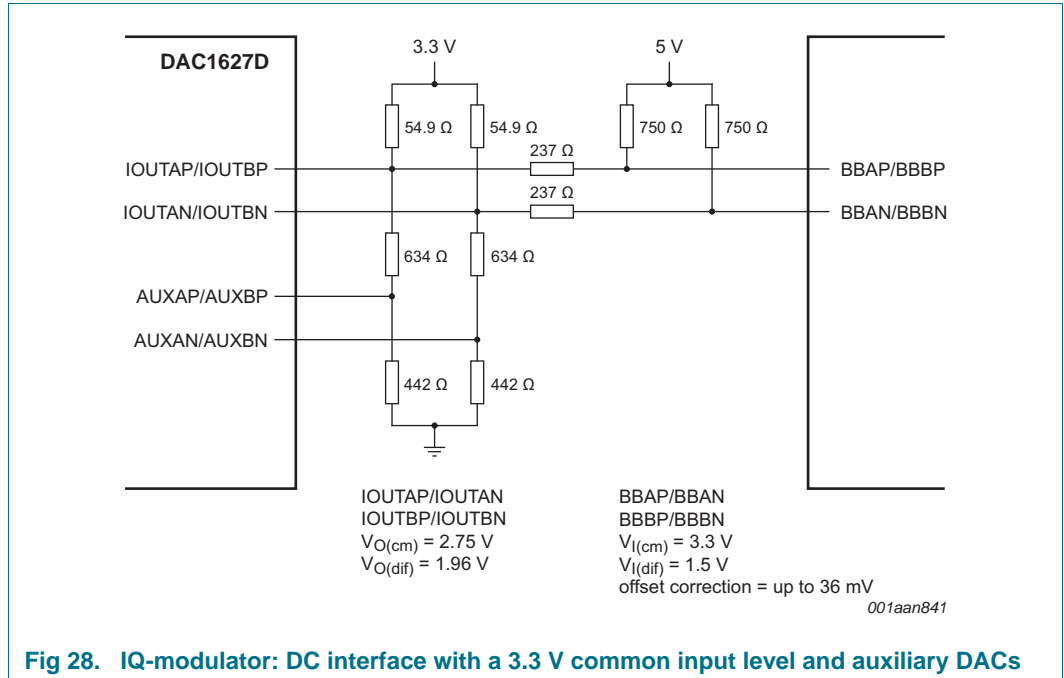

Figure 28 shows an example of a connection to an IQ-modulator with a 3.3 V common input level and auxiliary DACs.



The constraints to adjust the interface are:

- The output compliance range of the DAC
- The output compliance range of the auxiliary DACs
- The input common-mode level of the IQ-modulator
- The range of offset correction



The die pad is used for both the power dissipation and electrical grounding. Insert several vias (typically  $7 \times 7$ ) to connect the internal ground plane to the top layer die area.

## 10.18 Configuration interface

### 10.18.1 Register description

The DAC1627D1G25 incorporates more than the 32 SPI registers allowed by the address value A[4:0]. It uses three SPI register pages (page\_00, page\_01, and page\_0A), each containing 32 registers. The 32nd register of each page indicates which page is currently addressed (00h, 01h or 0Ah).

Page 00h (see [Table 23](#)) is dedicated to the main control of the DAC1627D1G25:

- Mode selection
- NCO control
- Auxiliary DAC control
- Gain/phase/offset control
- Power-down control

Page 01h (see [Table 55](#)) is dedicated to:

- Multi-Device Synchronization (MDS)
- DAC analog core control (biasing current, Sleep mode)

Page 0Ah (see [Table 79](#)) is dedicated to the LVDS input interface configuration.

## 10.18.2 Page 0 register allocation map

Table 23 shows an overview of all registers on page 0 (00h in hexadecimal). See [Section 10.18.3](#) for detailed descriptions of the registers.

**Table 23. Page\_00 register allocation map**

Address	Register name	R/W	Bit definition										Default		
			Bit 7	Bit 6	Bit 5	Bit 4	Bit 3	Bit 2	Bit 1	Bit 0	Bin	Hex	Dec		
0	00h	COMMON	R/W	3W_SPI	SPI_RST	-	-	-	CODING	IC_PON	GAP_PON	1000 0111	87h	135	
1	01h	TXCFG	R/W	NCO_ON	NCO_LP_SEL	INV_SIN_SEL	MODULATION[2:0]			INTERPOLATION[1:0]		0000 0001	01h	1	
2	02h	PLLCFG	R/W	PLL_BP	PLL_BUF_PD	PLL_PLL_PD	PLL_DIV[1:0]		PLL_PHASE[1:0]		PLL_OSC_PD	1010 0001	A1h	161	
4	04h	FREQNCO_B0	R/W	FREQ_NCO[7:0]								0110 0110	66h	102	
5	05h	FREQNCO_B1	R/W	FREQ_NCO[15:8]								0110 0110	66h	102	
6	06h	FREQNCO_B2	R/W	FREQ_NCO[23:16]								0110 0110	66h	102	
7	07h	FREQNCO_B3	R/W	FREQ_NCO[31:24]								0010 0110	66h	102	
8	08h	FREQNCO_B4	R/W	FREQ_NCO[39:32]								0010 0110	26h	38	
9	09h	PH_CORR_CTL0	R/W	PHASE_COR[7:0]								0000 0000	00h	0	
10	0Ah	PH_CORR_CTL1	R/W	PH_COR_ENA	-	-	PHASE_COR[12:8]					0000 0000	00h	0	
11	0Bh	DAC_A_DGAIN_LSB	R/W	DAC_A_DGAIN[7:0]								1101 0100	50h	80	
12	0Ch	DAC_A_DGAIN_MSB	R/W	-	-	-	-	DAC_A_DGAIN[11:8]				0000 1011	0Bh	11	
13	0Dh	DAC_B_DGAIN_LSB	R/W	DAC_B_DGAIN[7:0]								1101 0100	50h	80	
14	0Eh	DAC_B_DGAIN_MSB	R/W	-	-	-	-	DAC_B_DGAIN[11:8]				0000 0010	0Bh	11	
15	0Fh	DAC_OUT_CTRL	R/W	-	-	-	-	A_DGAIN_E	B_DGAIN_E	MINUS_3DB	CLIPPING_ENA	0000 0000	00h	0	

Table 23. Page\_00 register allocation map ...continued

Address	Register name	R/W	Bit definition								Default		
			Bit 7	Bit 6	Bit 5	Bit 4	Bit 3	Bit 2	Bit 1	Bit 0	Bin	Hex	Dec
16 10h	DAC_CLIPPING	R/W	CLIPPING_LEVEL[7:0]								1111 1111	FFh	255
17 11h	DAC_A_OFFSET_LSB	R/W	DAC_A_OFFSET[7:0]								0000 0000	00h	0
18 12h	DAC_A_OFFSET_MSB	R/W	DAC_A_OFFSET[15:8]								0000 0000	00h	0
19 13h	DAC_B_OFFSET_LSB	R/W	DAC_B_OFFSET[7:0]								0000 0000	00h	0
20 14h	DAC_B_OFFSET_MSB	R/W	DAC_B_OFFSET[15:8]								0000 0000	00h	0
21 15h	PHINCO_LSB	R/W	PH_NCO[7:0]								0000 0000	00h	0
22 16h	PHINCO_MSB	R/W	PH_NCO[15:8]								0000 0000	00h	0
23 17h	DAC_A_GAIN1	R/W	DAC_A_GAIN_COARSE[1:0]	DAC_A_GAIN_FINE[5:0]							0100 0000	40h	64
24 18h	DAC_A_GAIN2	R/W	DAC_A_GAIN_COARSE[3:2]	-	-	-	-	-	-	-	1000 0000	80h	128
25 19h	DAC_B_GAIN1	R/W	DAC_B_GAIN_COARSE[1:0]	DAC_B_GAIN_FINE[5:0]							0100 0000	40h	192
26 1Ah	DAC_B_GAIN2	R/W	DAC_B_GAIN_COARSE[3:2]	-	-	-	-	-	-	-	1000 0000	80h	128
27 1Bh	DAC_A_AUX_MSB	R/W	AUX_A[9:2]								1000 0000	80h	128
28 1Ch	DAC_A_AUX_LSB	R/W	AUX_A_PD	-	-	-	-	-	-	AUX_A[1:0]	0000 0000	00h	0
29 1Dh	DAC_B_AUX_MSB	R/W	AUX_B[9:2]								1000 0000	80h	128
30 1Eh	DAC_B_AUX_LSB	R/W	AUX_B_PD	-	-	-	-	-	-	AUX_B[1:0]	0000 0000	00h	0
31 1Fh	PAGE_ADDRESS	R/W	-	-	-	-	-	-	PAGE_ADD[2:0]		0000 0000	00h	0

10.18.3 Page 0 bit definition detailed description

Table 24. Register COMMON (address 00h) bit description

Default values are shown highlighted.

Bit	Symbol	Access	Value	Description
7	3W_SPI	R/W		serial interface bus type
			0	4-wire SPI
			1	<b>3-wire SPI</b>
6	SPI_RST	R/W		serial interface reset
			0	<b>no reset</b>
			1	performs a reset on all registers except address 00h
2	CODING	R/W		coding of input word
			0	two complement's coding
			1	<b>unsigned format</b>
1	IC_PON	R/W		IC power control
			0	all circuits (digital and analog, except SPI) are in power-down
			1	<b>all circuits (digital and analog, except SPI) are switched on</b>
0	GAP_PON	R/W		internal band gap power control
			0	band gap is power-down
			1	<b>internal band gap references are switched on</b>

Table 25. Register TXCFG (address 01h) bit description

Default values are shown highlighted.

Bit	Symbol	Access	Value	Description
7	NCO_ON	R/W		NCO
			0	<b>NCO disabled, the NCO phase is reset to 0</b>
			1	NCO enabled
6	NCO_LP_SEL	R/W		NCO low power selection
			0	<b>low power NCO disabled</b>
			1	low power NCO enabled (frequency and phase given by the five MSB of the registers 06h and 08h, respectively)
5	INV_SIN_SEL	R/W		inverse (sin x) / x function selection
			0	<b>disable</b>
			1	enable
4 to 2	MODULATION[2:0]	R/W		modulation
			000	<b>dual DAC: no modulation</b>
			001	positive upper single sideband upconversion
			010	positive lower single sideband upconversion
			011	negative upper single sideband upconversion
			100	negative lower single sideband upconversion
			others	not defined

**Table 25. Register TXCFG (address 01h) bit description ...continued**

Default values are shown highlighted.

Bit	Symbol	Access	Value	Description
1 to 0	INTERPOLATION[1:0]	R/W		interpolation
			00	no interpolation
			<b>01</b>	<b>×2 interpolation</b>
			10	×4 interpolation
			11	×8 interpolation

**Table 26. Register PLLCFG (address 02h) bit description**

Default values are shown highlighted.

Bit	Symbol	Access	Value	Description
7	PLL_BP	R/W		PLL bypass
			0	DAC clock generated by PLL
			<b>1</b>	<b>DAC clock provided via external pins CLKN and CLKP (PLL bypass mode)</b>
6	PLL_BUF_PD	R/W		PLL test buffer control
			<b>0</b>	<b>Power-down mode</b>
			1	enabled
5	PLL_PLL_PD	R/W		PLL and CKGEN control
			0	Power-down mode
			<b>1</b>	<b>enable</b>
4 to 3	PLL_DIV[1:0]	R/W		PLL divider factor
			<b>00</b>	<b><math>f_s = 2 \times f_{data}</math></b>
			01	$f_s = 4 \times f_{data}$
			10	$f_s = 8 \times f$
			11	undefined
2 to 1	PLL_PHASE[1:0]	R/W		PLL phase shift
			<b>00</b>	<b>0 degrees phase shift of <math>f_s</math></b>
			01	120 degrees phase shift of $f_s$
			10	240 degrees phase shift of $f_s$
			11	240 degrees phase shift of $f_s$
0	PLL_OSC_PD	R/W		PLL oscillator output power-down
			0	Power-down mode
			<b>1</b>	<b>enabled</b>

**Table 27. Register FREQNCO\_B0 (address 04h)**

Default values are shown highlighted.

Bit	Symbol	Access	Value	Description
7 to 0	FREQ_NCO[7:0]	R/W		NCO frequency (two complement's coding)
			-	least significant 8 bits for the NCO frequency setting

**Table 28. Register FREQNCO\_B1 (address 05h)**

Default values are shown highlighted.

Bit	Symbol	Access	Value	Description
7 to 0	FREQ_NCO[15:8]	R/W		NCO frequency
			-	intermediate 8 bits for the NCO frequency setting

**Table 29. Register FREQNCO\_B2 (address 06h)**

Default values are shown highlighted.

Bit	Symbol	Access	Value	Description
7 to 0	FREQ_NCO[23:16]	R/W		NCO frequency
			-	intermediate 8 bits for the NCO frequency setting

**Table 30. Register FREQNCO\_B3 (address 07h)**

Default values are shown highlighted.

Bit	Symbol	Access	Value	Description
7 to 0	FREQ_NCO[31:24]	R/W		NCO frequency
			-	intermediate 8 bits for the NCO frequency setting

**Table 31. Register FREQNCO\_B4 (address 08h)**

Default values are shown highlighted.

Bit	Symbol	Access	Value	Description
7 to 0	FREQ_NCO[39:32]	R/W		NCO frequency (MSB)
			-	most significant 8 bits for the NCO frequency setting

**Table 32. Register PH\_CORR\_CTL0 (address 09h)**

Default values are shown highlighted.

Bit	Symbol	Access	Value	Description
7 to 0	PHASE_COR[7:0]]	R/W		DAC output phase correction factor (LSB)
			-	least significant 8 bits for the DAC output phase correction factor

**Table 33. Register PH\_CORR\_CTL1 (address 0Ah)**

Default values are shown highlighted.

Bit	Symbol	Access	Value	Description
7	PH_COR_ENA	R/W		DAC output phase correction control
			0	<b>DAC output phase correction disabled</b>
			1	DAC output phase correction enabled
4 to 0	PHASE_COR[12:8]	R/W		DAC output phase correction factor MSB
			00000	most significant 5 bits for the DAC output phase correction factor

**Table 34. Register DAC\_A\_DGAIN\_LSB (address 0Bh)**

Default values are shown highlighted.

Bit	Symbol	Access	Value	Description
7 to 0	DAC_A_DGAIN[7:0]	R/W		DAC A digital gain control
			-	least significant 8 bits for the DAC A digital gain

**Table 35. Register DAC\_A\_DGAIN\_MSB (address 0Ch)**

Default values are shown highlighted.

Bit	Symbol	Access	Value	Description
3 to 0	DAC_A_DGAIN[11:8]	R/W	-	DAC A digital gain control most significant 4 bits for the DAC A digital gain

**Table 36. Register DAC\_B\_DGAIN\_LSB (address 0Dh)**

Default values are shown highlighted.

Bit	Symbol	Access	Value	Description
7 to 0	DAC_B_DGAIN[7:0]	R/W	-	DAC B digital gain control least significant 8 bits for the DAC B digital gain

**Table 37. Register DAC\_B\_DGAIN\_MSB (address 0Eh)**

Default values are shown highlighted.

Bit	Symbol	Access	Value	Description
3 to 0	DAC_B_DGAIN[11:8]	R/W	-	DAC B digital gain control most significant 4 bits for the DAC B digital gain

**Table 38. Register DAC\_OUT\_CTRL (address 0Fh)**

Default values are shown highlighted.

Bit	Symbol	Access	Value	Description
3	A_DGAIN_E	R/W	0	disable
			1	enable
2	B_DGAIN_E	R/W	0	disable
			1	enable
1	MINUS_3DB	R/W	0	unity gain
			1	-3 dB gain
0	CLIPPING_ENA	R/W	0	disable
			1	enable

**Table 39. Register DAC\_CLIPPING (address 10h)**

Default values are shown highlighted.

Bit	Symbol	Access	Value	Description
7 to 0	CLIPPING_LEVEL[7:0]	R/W	-	Digital DAC output clipping level value

**Table 40. Register DAC\_A\_OFFSET\_LSB (address 11h)**

Default values are shown highlighted.

Bit	Symbol	Access	Value	Description
7 to 0	DAC_A_OFFSET[7:0]	R/W	-	DAC A digital offset value least significant 8 bits for the DAC A digital offset

**Table 41. Register DAC\_A\_OFFSET\_MSB (address 12h)**

Default values are shown highlighted.

Bit	Symbol	Access	Value	Description
7 to 0	DAC_A_OFFSET[15:8]	R/W	-	DAC A digital offset value most significant 8 bits for the DAC A digital offset

**Table 42. Register DAC\_B\_OFFSET\_LSB (address 13h)**

Default values are shown highlighted.

Bit	Symbol	Access	Value	Description
7 to 0	DAC_B_OFFSET[7:0]	R/W	-	DAC B digital offset value least significant 8 bits for the DAC B digital offset

**Table 43. Register DAC\_B\_OFFSET\_MSB (address 14h)**

Default values are shown highlighted.

Bit	Symbol	Access	Value	Description
7 to 0	DAC_B_OFFSET[15:8]	R/W	-	DAC B digital offset value most significant 8 bits for the DAC B digital offset

**Table 44. Register PHINCO\_LSB (address 15h)**

Default values are shown highlighted.

Bit	Symbol	Access	Value	Description
7 to 0	PH_NCO[7:0]	R/W	-	NCO phase offset LSB least significant 8 bits for the NCO phase setting

**Table 45. Register PHINCO\_MSB (address 16h)**

Default values are shown highlighted.

Bit	Symbol	Access	Value	Description
7 to 0	PH_NCO[15:8]	R/W	-	NCO phase offset MSB most significant 8 bits for the NCO phase setting

**Table 46. Register DAC\_A\_GAIN1 (address 17h)**

Default values are shown highlighted.

Bit	Symbol	Access	Value	Description
7 to 6	DAC_A_GAIN_COARSE[1:0]	R/W	-	DAC A analog coarse gain control (LSB)
5 to 0	DAC_A_GAIN_FINE[5:0]	R/W	-	DAC A analog fine gain control

**Table 47. Register DAC\_A\_GAIN2 (address 18h)**

Default values are shown highlighted.

Bit	Symbol	Access	Value	Description
7 to 6	DAC_A_GAIN_COARSE[3:2]	R/W	-	DAC A analog gain coarse control (MSB)

**Table 48. Register DAC\_B\_GAIN1 (address 19h)**

Default values are shown highlighted.

Bit	Symbol	Access	Value	Description
7 to 6	DAC_B_GAIN_COARSE[1:0]	R/W	-	DAC B analog coarse gain control (LSB)
5 to 0	DAC_B_GAIN_FINE[5:0]	R/W	-	DAC B analog fine gain control

**Table 49. Register DAC\_B\_GAIN2 (address 1Ah)**

Default values are shown highlighted.

Bit	Symbol	Access	Value	Description
7 to 6	DAC_B_GAIN_COARSE[3:2]	R/W	-	DAC B analog coarse gain control (MSB)

**Table 50. DAC\_A\_Aux\_MSB register (address 1Bh) bit description**

Default values are shown highlighted.

Bit	Symbol	Access	Value	Description
7 to 0	AUX_A[9:2]	R/W	-	most significant 8 bits for auxiliary DAC A

**Table 51. DAC\_A\_Aux\_LSB register (address 1Ch) bit description**

Default values are shown highlighted.

Bit	Symbol	Access	Value	Description
7	AUX_A_PD	R/W		auxiliary DAC A power
			0	on
			1	off
1 to 0	AUX_A[1:0]	R/W	-	least significant 2 bits for auxiliary DAC A

**Table 52. DAC\_B\_Aux\_MSB register (address 1Dh) bit description**

Default values are shown highlighted.

Bit	Symbol	Access	Value	Description
7 to 0	AUX_B[9:2]	R/W	-	most significant 8 bits for auxiliary DAC B

**Table 53. DAC\_B\_Aux\_LSB register (address 1Eh) bit description**

Default values are shown highlighted.

Bit	Symbol	Access	Value	Description
7	AUX_B_PD	R/W		auxiliary DAC B power
			0	on
			1	off
1 to 0	AUX_B[1:0]	R/W	-	least significant 2 bits for auxiliary DAC B

**Table 54. SPI\_PAGE register (address 1Fh) bit description**

Default values are shown highlighted.

Bit	Symbol	Access	Value	Description
2 to 0	PAGE[2:0]	R/W	-	SPI page address

## 10.18.4 Page 1 allocation map

[Table 55](#) shows an overview of all registers on page 1 (01h in hexadecimal). See [Section 10.18.5](#) for detailed descriptions of the registers.

**Table 55. Page 1 register allocation map**

Address	Register name	R/W	Bit definition									Default <sup>[1]</sup>			
			Bit 7	Bit 6	Bit 5	Bit 4	Bit 3	Bit 2	Bit 1	Bit 0	Bin	Hex			
0	00h	MDS_MAIN	R/W	MDS_EQCHECK[1:0]		MDS_RUN	MDS_NCO	MDS_NCO_PULSE	MDS_SREF_DIS	MDS_MASTER	MDS_ENA	0000 0100	04h		
1	01h	MDS_WIN_PERIOD_A	R/W	MDS_WIN_PERIOD_A[7:0]									1000 0000	80h	
2	02h	MDS_WIN_PERIOD_B	R/W	MDS_WIN_PERIOD_B[7:0]									0100 0000	40h	
3	03h	MDS_MISCCNTRL0	R/W	-	-	-	MDS_EVAL_ENA	MDS_PRERUN_E	MDS_PULSEWIDTH[2:0]			0001 0000	10h		
4	04h	MDS_MAN_ADJUSTDLY	R/W	MDS_MAN	MDS_MAN_ADJUSTDLY[6:0]									0100 0000	40h
5	05h	MDS_AUTO_CYCLES	R/W	MDS_AUTO_CYCLES[7:0]									1000 0000	80h	
6	06h	MDS_MISCCNTRL1	R/W	MDS_SR_CKEN	MDS_SR_LOCKOUT	MDS_SR_LOCK	MDS_RELOCK	MDS_LOCK_DELAY[3:0]				0000 1111	0Fh		
7	07h	MDS_OFFSET_DLY	RW	-	-	-	MDS_OFFSET_DLY[4:0]					0000 0000	00h		
8	08h	MDS_ADJDELAY	RW	-	MDS_ADJDELAY[6:0]									0000 0000	00h
9	09h	MDS_STATUS0	R	EARLY	LATE	EQUAL	MDS_EQ	EARLY_ERROR	LATE_ERROR	EQUAL_FOUND	MDS_ACTIVE	uuuu uuuu	uuh		
10	0Ah	MDS_STATUS1	R	-	-	ADD_ERR	MDS_EN_PHASE[1:0]		MDS_PRERUN	MDS_LOCKOUT	MDS_LOCK	uuuu uuuu	uuh		
14	0Eh	DAC_CURRENT_AUX	R/W	-	-	-	-	DAC_AUX_BIAS[3:0]				0000 0011	03h		
15	0Fh	DAC_CURRENT_0	R/W	-	-	-	-	DAC_DIG_BIAS[3:0]				0000 0011	03h		
16	10h	DAC_CURRENT_1	R/W	-	-	-	-	DAC_MST_BIAS[3:0]				0000 0011	03h		

Table 55. Page 1 register allocation map ...continued

Address	Register name	R/W	Bit definition									Default <sup>[1]</sup>		
			Bit 7	Bit 6	Bit 5	Bit 4	Bit 3	Bit 2	Bit 1	Bit 0	Bin	Hex		
17 11h	DAC_CURRENT_2	R/W	-	-	-	-							0000 0011	03h
18 12h	DAC_CURRENT_3	R/W	-	-	-	-							0000 0011	03h
19 13h	DAC_CURRENT_4	R/W	-	-	-	-							0000 0011	03h
20 14h	DAC_CURRENT_5	R/W	-	-	-	-							0000 0011	03h
21 15h	DAC_CURRENT_6	R/W	-	-	-	-							0000 0011	03h
22 16h	DAC_PON_SLEEP	R/W	DAC_B_PON	DAC_B_SLEEP	DAC_B_COM_PD	DAC_B_BLEED_PD	DAC_A_PD	DAC_A_SLEEP	DAC_A_COM_PD	DAC_A_BLEED_PD			1011 1011	BBh
23 17h	DAC_CLKDIG_DELAY	R/W	-	-	-	-	-						0000 0010	02h
31 1Fh	PAGE_ADDRESS	R/W	-	-	-	-	-						0000 0000	00h

[1] u = undefined at power-up or after reset.

## 10.18.5 Page 1 bit definition detailed description

Table 56. MDS\_MAIN register (address 00h) bit description

Default values are shown highlighted.

Bit	Symbol	Access	Value	Description
7 to 6	MDS_EQCHECK[1:0]	R/W		lock mode
			<b>00</b>	<b>lock when (early = 1 and late = 1)</b>
			01	lock when (early = 1, late = 1 and equal = 1)
			10	lock when equal = 1
			11	force lock (equal-check = 1)
5	MDS_RUN	R/W		evaluation process restart control
			<b>0</b>	<b>no action</b>
4	MDS_NCO	R/W		NCO synchronization
			<b>0</b>	<b>no action</b>
3	MDS_NCO_PULSE	R/W		NCO pulse
			<b>0</b>	<b>no action</b>
2	MDS_SREF_DIS	R/W		internal pulse generation
			<b>0</b>	normal mode
1	MDS_MASTER	R/W		MDS mode selection
			<b>0</b>	<b>slave mode</b>
0	MDS_ENA	R/W		MDS function control
			<b>0</b>	<b>disable</b>
			1	enable

Table 57. MDS\_WIN\_PERIOD\_A register (address 01h) bit description

Default values are shown highlighted.

Bit	Symbol	Access	Value	Description
7 to 0	MDS_WIN_PERIOD_A[7:0]	R/W	-	determines MDS window LOW time

Table 58. MDS\_WIN\_PERIOD\_B register (address 02h) bit description

Default values are shown highlighted.

Bit	Symbol	Access	Value	Description
7 to 0	MDS_WIN_PERIOD_B[7:0]	R/W	-	determines MDS window HIGH time

Table 59. MDS\_MISCCNTRL0 register (address 03h) bit description

Default values are shown highlighted.

Bit	Symbol	Access	Value	Description
4	MDS_EVAL_ENA	R/W		MDS evaluation
			<b>0</b>	disable
			<b>1</b>	<b>enable</b>

**Table 59. MDS\_MISCCNTRL0 register (address 03h) bit description ...continued**

Default values are shown highlighted.

Bit	Symbol	Access	Value	Description
3	MDS_PRERUN_ENA	R/W		automatic MDS start-up
			<b>0</b>	<b>no mds_win/mds_ref generation in advance</b>
			1	mds_win/mds_ref run-in before mds_evaluation
2 to 0	MDS_PULSEWIDTH[2:0]	R/W		width of MDS (in output clk-periods)
			<b>000</b>	<b>1 DAC clk-period</b>
			001	2 DAC clk-periods
			010 to 111	(mds_pulsewidth – 1) × 4 DAC clk-periods

**Table 60. MDS\_MAN\_ADJUSTDLY register (address 04h) bit description**

Default values are shown highlighted.

Bit	Symbol	Access	Value	Description
7	MDS_MAN	R/W		adjustment delays mode
			<b>0</b>	<b>auto-control adjustment delays</b>
			1	manual control adjustment delays
6 to 0	MDS_MAN_ADJUSTDLY[6:0]	R/W		adjustment delay value
			-	if MDS_MAN = 0 then initial value adjustment delay
			-	if MDS_MAN = 1 then controls adjustment delay

**Table 61. MDS\_AUTO\_CYCLES register (address 05h) bit description**

Default values are shown highlighted.

Bit	Symbol	Access	Value	Description
7 to 0	MDS_AUTO_CYCLES[7:0]	R/W	-	number of evaluation cycles applied for MDS. If set to 255 then IC continuously generates/monitors the MDS pulse

**Table 62. MDS\_MISCCNTRL1 register (address 06h) bit description**

Default values are shown highlighted.

Bit	Symbol	Access	Value	Description
7	MDS_SR_CKEN	R/W	-	lock mode
			<b>0</b>	<b>free-running MDS_SR_CKEN</b>
			1	MDS_SR_CKEN forced low
6	MDS_SR_LOCKOUT	R/W		lockout detector soft reset
			<b>0</b>	<b>MDS_SR_LOCKOUT in use</b>
			1	MDS_SR_LOCKOUT forced low
5	MDS_SR_LOCK	R/W		lock detector soft reset
			<b>0</b>	<b>MDS_SR_LOCK in use</b>
			1	MDS_SR_LOCK forced low
4	MDS_RELOCK	R/W		relock mode
			<b>0</b>	<b>no action</b>
			1	relock when lockout occurs
3 to 0	MDS_LOCK_DELAY[3:0]	R/W	-	number of succeeding 'equal'-detections until lock

**Table 63. MDS\_OFFSET\_DLY register (address 07h) bit description**

Default values are shown highlighted.

Bit	Symbol	Access	Value	Description
4 to 0	MDS_OFFSET_DLY[6:0]	R/W	-	delay offset for dataflow (two's complement [-16 to 15])

**Table 64. MDS\_ADJDELAY register (address 08h) bit description**

Default values are shown highlighted.

Bit	Symbol	Access	Value	Description
6 to 0	MDS_ADJDELAY[6:0]	R	-	actual value adjustment delay

**Table 65. MDS\_STATUS0 register (address 09h) bit description**

Default values are shown highlighted.

Bit	Symbol	Access	Value	Description
7	EARLY	R		early signal (sampled) from early-to-late detector
			0	false
			1	true
6	LATE	R		late signal (sampled) from early-to-late detector
			0	false
			1	true
5	EQUAL	R		equal signal (sampled) from early-to-late detector
			0	false
			1	true
4	MDS_LOCK	R		result equal-check
			0	false
			1	true
3	EARLY_ERROR	R		adjustment delay maximum value stops the search
			0	false
			1	true
2	LATE_ERROR	R		adjustment delay minimum value stops the search
			0	false
			1	true
1	EQUAL_FOUND	R		evaluation logic has detected equal condition
			0	false
			1	true
0	MDS_ACTIVE	R		evaluation logic active
			0	false
			1	true

**Table 66. MDS\_STATUS1 register (address 0Ah) bit description**

Default values are shown highlighted.

Bit	Symbol	Access	Value	Description
5	ADD_ERR	R		adjustment delay error detection
			0	OK
			1	delay offset cannot be applied in available range

**Table 66. MDS\_STATUS1 register (address 0Ah) bit description ...continued**

Default values are shown highlighted.

Bit	Symbol	Access	Value	Description
4 to 3	MDS_EN_PHASE[1:0]	R		MDS enable phase
			00	enable phase = 0
			01	enable phase = 1 (only for x2)
			10	enable phase = 2 (only for x2 and x4)
			11	enable phase = 3 (only for x2)
2	MDS_PRERUN	R		MDS-PRERUN phase active flag
			0	false
			1	true
1	MDS_LOCKOUT	R		MDS_LOCKOUT detected flag
			0	false
			1	true
0	MDS_LOCK	R		MDS_LOCK flag
			0	false
			1	true

**Table 67. DAC\_CURRENT\_AUX register (address 0Eh) bit description**

Default values are shown highlighted.

Bit	Symbol	Access	Value	Description
3 to 0	DAC_AUX_BIAS[3:0]	R/W	-	bias current control (see <a href="#">Table 75</a> )

**Table 68. DAC\_CURRENT\_0 register (address 0Fh) bit description**

Default values are shown highlighted.

Bit	Symbol	Access	Value	Description
3 to 0	DAC_DIG_BIAS[3:0]	R/W	-	bias current control (see <a href="#">Table 75</a> )

**Table 69. DAC\_CURRENT\_1 register (address 10h) bit description**

Default values are shown highlighted.

Bit	Symbol	Access	Value	Description
3 to 0	DAC_MST_BIAS[3:0]	R/W	-	bias current control (see <a href="#">Table 75</a> )

**Table 70. DAC\_CURRENT\_2 register (address 11h) bit description**

Default values are shown highlighted.

Bit	Symbol	Access	Value	Description
3 to 0	DAC_DRV_BIAS[3:0]	R/W	-	bias current control (see <a href="#">Table 75</a> )

**Table 71. DAC\_CURRENT\_3 register (address 12h) bit description**

Default values are shown highlighted.

Bit	Symbol	Access	Value	Description
3 to 0	DAC_SLV_BIAS[3:0]	R/W	-	bias current control (see <a href="#">Table 75</a> )

**Table 72. DAC\_CURRENT\_4 register (address 13h) bit description**

Default values are shown highlighted.

Bit	Symbol	Access	Value	Description
3 to 0	DAC_CK_BIAS[3:0]	R/W	-	bias current control (see <a href="#">Table 75</a> )

**Table 73. DAC\_CURRENT\_5 register (address 14h) bit description**

Default values are shown highlighted.

Bit	Symbol	Access	Value	Description
3 to 0	DAC_CAS_BIAS[3:0]	R/W	-	bias current control (see <a href="#">Table 75</a> )

**Table 74. DAC\_CURRENT\_6 register (address 15h) bit description**

Default values are shown highlighted.

Bit	Symbol	Access	Value	Description
3 to 0	DAC_BLD_BIAS[3:0]	R/W	-	bias current control (see <a href="#">Table 75</a> )

**Table 75. Bias current control table**

BIAS[3:0]	Deviation from nominal current
0 0 0	-30 %
0 0 1	-20 %
0 1 0	-10 %
0 1 1	0 %
1 0 0	+10 %
1 0 1	+20 %
1 1 0	+30 %
1 1 1	+40 %

**Table 76. DAC\_PON\_SLEEP register (address 16h) bit description**

Default values are shown highlighted.

Bit	Symbol	Access	Value	Description
7	DAC_B_PON	R/W	-	DAC B power control
			0	power-down
			<b>1</b>	<b>power on</b>
6	DAC_B_SLEEP	R		DAC B mode selection
			<b>0</b>	<b>normal operation</b>
			1	Sleep mode
5	DAC_B_COM_PD	R		commutator B control
			0	disable (power-down)
			<b>1</b>	<b>enable</b>
4	DAC_B_BLEED_PD	R		DAC B bleed current control
			0	disable (power-down)
			<b>1</b>	<b>enable</b>
3	DAC_A_PON	R		DAC A power control
			0	power-down
			<b>1</b>	<b>power on</b>

**Table 76. DAC\_PON\_SLEEP register (address 16h) bit description ...continued***Default values are shown highlighted.*

Bit	Symbol	Access	Value	Description
2	DAC_A_SLEEP	R		DAC B mode selection
			<b>0</b>	<b>normal operation</b>
			1	Sleep mode
1	DAC_A_COM_PD	R		commutator A control
			0	disable (power-down)
			<b>1</b>	<b>enable</b>
0	DAC_A_BLEED_PD	R		DAC A bleed current control
			0	disable (power-down)
			<b>1</b>	<b>enable</b>

**Table 77. DAC\_TEST\_8 register (address 17h) bit description***Default values are shown highlighted.*

Bit	Symbol	Access	Value	Description
2 to 0	PLL_DIG_DELAY[2:0]	R/W	-	digital clock delay offset of PLL/CKGEN_DIV8

**Table 78. SPI\_PAGE register (address 1Fh) bit description***Default values are shown highlighted.*

Bit	Symbol	Access	Value	Description
2 to 0	PAGE[2:0]	R/W	-	SPI page address

## 10.18.6 Page A register allocation map

Table 79 shows an overview of all registers on page A (0Ah in hexadecimal). See [Section 10.18.7](#) for detailed descriptions of the registers.

**Table 79. Page\_0A register allocation map**

Address	Register name	R/W	Bit definition									Default			
			Bit 7	Bit 6	Bit 5	Bit 4	Bit 3	Bit 2	Bit 1	Bit 0	Bin	Hex	Dec		
0	00h	MAIN_CNTRL	R/W	-	-	-	LD_PD	PD_CNTRL	CAL_CNTRL	RST_DCKL	RST_LCKL	0000 0011	03h	3	
1	01h	MAN_LDCLKDEL	R/W	-	-	-	-	LDCLK_DEL[3:0]			0000 0000	00h	0		
2	02h	DBG_LVDS	R/W	-	-	-	-	SBER	RESERVED			0000 0000	00h	0	
4	04h	RST_EXT_LDCLK	R/W	RST_EXT_LCLK_TIME[7:0]									0011 1111	3Fh	63
5	05h	RST_EXT_DCLK	R/W	RST_EXT_DCLK_TIME[7:0]									0010 0000	20h	32
6	06h	DCMSU_PREDIV	R/W	DCMSU_PREDIVIDER[7:0]									0001 1110	1Eh	30
8	08h	LD_POL_LSB	R/W	LD_POL[7:0]									0000 0000	00h	0
9	09h	LD_POL_MSB	R/W	LD_POL[15:8]									0000 0000	00h	0
10	0Ah	LD_CNTRL	R/W	PARITYC	DESCRAMBLE	SEL_EN[1:0]	WORD_SWAP	LDAB_SWAP	IQ_FORMAT	EDGE_LDCLK	0000 0011	03h	3		
11	0Bh	MISC_CNTRL	R/W	SR_CDI	RESERVED	I_LEV_CNTRL[1:0]	Q_LEV_CNTRL[1:0]		CDI_MODE[1:0]		0000 0000	00h	0		
12	0Ch	I_DC_LVL_LSB	R/W	I_DC_LEVEL[7:0]									0000 0000	00h	0
13	0Dh	I_DC_LVL_MSB	R/W	I_DC_LEVEL[15:8]									0100 0000	20h	32
14	0Eh	Q_DC_LVL_LSB	R/W	Q_DC_LEVEL[7:0]									0000 0000	00h	0
15	0Fh	Q_DC_LVL_MSB	R/W	Q_DC_LEVEL[15:8]									0100 0000	20h	32
27	1Bh	TYPE_ID	R	DAC	FRONTEND[1:0]	DUAL	DSP[1:0]		BIT_RES[1:0]		0011 1010	3Ch	60		

Table 79. Page\_0A register allocation map ...continued

Address	Register name	R/W	Bit definition									Default					
			Bit 7	Bit 6	Bit 5	Bit 4	Bit 3	Bit 2	Bit 1	Bit 0	Bin	Hex	Dec				
28	1Ch	DAC_VERSION	R				DAC_VERSION_ID[7:0]						0000 0001	01h	1		
29	1Dh	DIG_VERSION	R				DIG_VERSION_ID[7:0]						0000 0001	01h	1		
30	1Eh	LD_VERSION	R				LVDS_VERSION_ID[7:0]						0000 0001	01h	1		
31	1Fh	PAGE_ADDRESS	R/W	-	-	-	-	-		PAGE_ADD[2:0]					0000 0000	00h	0

## 10.18.7 Page A bit definition detailed description

Table 80. Register MAIN\_CNTRL (address 00h)

Default values are shown highlighted.

Bit	Symbol	Access	Value	Description
4	LD_PD	R/W		LVDS interface power-down (control possible only when PD_CNTRL = 1)
			<b>0</b>	<b>switched on</b>
			1	switched off
3	PD_CNTRL	R/W		power-down modes controlled by
			<b>0</b>	<b>DCMSU block</b>
			1	SPI registers
2	CAL_CNTRL	R/W		compensation delay controlled by
			<b>0</b>	<b>DCMSU block (automatic calibration)</b>
			1	SPI registers (manual control)
1	RST_DCLK	R/W		reset DCLK
			0	disable
			<b>1</b>	<b>enable</b>
0	RST_LCLK	R/W		reset LVDS clock
			0	disable
			<b>1</b>	<b>enable</b>

Table 81. Register MAN\_LDCLKDEL (address 01h)

Default values are shown highlighted.

Bit	Symbol	Access	Value	Description
3 to 0	LDCLK_DEL[3:0]	R/W		LVDS clock compensation delay (control only if CAL_CNTRL = 1)
			-	4-bit compensation delay for LVDS clock

Table 82. Register DBG\_LVDS (address 02h)

Default values are shown highlighted.

Bit	Symbol	Access	Value	Description
3	SBER	R/W		simple BER control
			<b>0</b>	<b>no action</b>
			1	simple BER active
2 to 0	RESERVED	R/W	<b>000</b>	<b>reserved</b>

Table 83. Register RST\_EXT\_LCLK (address 04h)

Default values are shown highlighted.

Bit	Symbol	Access	Value	Description
7 to 0	RST_EXT_LCLK_TIME[7:0]	R/W		specify extension time reset, expressed in LVDS clock period
			-	8 bits for the extension time reset

**Table 84. Register RST\_EXT\_DCLK (address 05h)**

Default values are shown highlighted.

Bit	Symbol	Access	Value	Description
7 to 0	RST_EXT_DCLK_TIME[7:0]	R/W		specify extension time reset, expressed in DCLK period
			-	8 bits for the extension time reset

**Table 85. Register DCMSU\_PREDIV (address 06h)**

Default values are shown highlighted.

Bit	Symbol	Access	Value	Description
7 to 0	DCMSU_PREDIVIDER[7:0]	R/W		predivider value for the DCMSU, expressed in LVDS clock period
			-	8 bits for the predivider value

**Table 86. Register LD\_POL\_LSB (address 08h)**

Default values are shown highlighted.

Bit	Symbol	Access	Value	Description
7 to 0	LD_POL[7:0]	R/W		toggles polarity of corresponding bit pair within LD[7:0]
			-	most significant 6 bits for the polarity toggle

**Table 87. Register LD\_POL\_MSB (address 09h)**

Default values are shown highlighted.

Bit	Symbol	Access	Value	Description
7 to 0	LD_POL[15:8]	R/W		toggles polarity of corresponding bit pair within LD[7:0]
			-	most significant 6 bits for the polarity toggle

**Table 88. Register LD\_CNTRL (address 0Ah)**

Default values are shown highlighted.

Bit	Symbol	Access	Value	Description
7	PARITYC	R/W		parity check
			0	disable
			1	enable
6	DESCRAMBLE	R/W		Descramble control
			<b>0</b>	<b>disable descrambling</b>
			1	enable descrambling
5 to 4	SEL_EN[1:0]	R/W		LDVS data enable
			<b>00</b>	<b>LDVS data enable = align signal from channel A</b>
			01	LDVS data enable = align signal from channel B
			10	LDVS data enable = 0
			11	LDVS data enable = 1
3	WORD_SWAP	R/W		reverse order for LVDS path
			<b>0</b>	<b>normal operation</b>
			1	MSB to LSB order reversed

**Table 88. Register LD\_CNTRL (address 0Ah) ...continued**  
 Default values are shown highlighted.

Bit	Symbol	Access	Value	Description
2	LDAB_SWAP	R/W		swaps LVDS A and LVDS B paths
			<b>0</b>	<b>normal operation</b>
			1	LVDS A and LVDS B paths are swapped
1	IQ_FORMAT	R/W		specify IQ supplied format
			0	folded
			<b>1</b>	<b>interleaved</b>
0	EDGE_LDCLK	R/W		specify sampling edge for LVDS data path
			0	falling edge of LDCLK
			<b>1</b>	<b>rising edge of LDCLK</b>

**Table 89. Register MISC\_CNTRL (address 0Bh)**  
 Default values are shown highlighted.

Bit	Symbol	Access	Value	Description
7	SR_CDI	R/W		CDI block software reset control
			<b>0</b>	<b>no action</b>
			1	perform a software reset on CDI
6	RESERVED	R/W	0	reserved
5 to 4	I_LEV_CNTRL[1:0]	R/W		specifies output from CDI for I path
			<b>00</b>	<b>normal operation (CDI data output sent to digital signal processing input)</b>
			01	if LDVS data enable = 1, then normal operation; if LDVS data enable = 0, then digital signal processing input = I_DC_LEVEL register value
			10	digital signal processing input = I_DC_LEVEL
			11	digital signal processing input = I_DC_LEVEL
3 to 2	Q_LEV_CNTRL[1:0]	R/W		specifies output from CDI for Q path
			<b>00</b>	<b>normal operation (CDI data output sent to digital signal processing input)</b>
			01	if LDVS data enable = 1, then normal operation; if LDVS data enable = 0, then digital signal processing input = Q_DC_LEVEL register value
			10	digital signal processing input = Q_DC_LEVEL
			11	digital signal processing input = Q_DC_LEVEL
1 to 0	CDI_MODE[1:0]	R/W		specifies CDI mode
			<b>00</b>	<b>cdi_mode 0 (x2 mode)</b>
			01	cdi_mode 1 (x4 mode)
			10	cdi_mode 2 (x8 mode)
			11	not used

**Table 90. Register I\_DC\_LVL\_LSB(address 0Ch)**

Default values are shown highlighted.

Bit	Symbol	Access	Value	Description
7 to 0	I_DC_LEVEL[7:0]	R/W	-	I_DC_LEVEL least significant 8 bits for I_DC_LEVEL

**Table 91. Register I\_DC\_LVL\_MSB(address 0Dh)**

Default values are shown highlighted.

Bit	Symbol	Access	Value	Description
7 to 0	I_DC_LEVEL[15:8]	R/W	-	I_DC_LEVEL most significant 8 bits for I_DC_LEVEL

**Table 92. Register Q\_DC\_LVL\_LSB(address 0Eh)**

Default values are shown highlighted.

Bit	Symbol	Access	Value	Description
7 to 0	Q_DC_LEVEL[7:0]	R/W	-	Q_DC_LEVEL least significant 8 bits for Q_DC_LEVEL

**Table 93. Register Q\_DC\_LVL\_MSB(address 0Fh)**

Default values are shown highlighted.

Bit	Symbol	Access	Value	Description
7 to 0	Q_DC_LEVEL[15:8]	R/W	-	Q_DC_LEVEL most significant 8 bits for Q_DC_LEVEL

**Table 94. Register TYPE\_ID (address 1Bh)**

Default values are shown highlighted.

Bit	Symbol	Access	Value	Description
7	DAC	R	0 1	calibration uncalibrated device <b>calibrated device</b>
6 to 5	FRONTEND	R	<b>01</b>	<b>LVDS input interface</b>
4	DUAL	R	0	dual DAC
3 to 2	DSP	R	11 10 01 00	internal digital signal processing interpolation filter + SSBM SSBM interpolation filter none
1 to 0	BIT_RES	R	00 01 10 11	DAC bit resolution <b>16 bits</b> 14 bits 12 bits 10 bits

**Table 95. Register DAC\_VERSION (address 1Ch)***Default values are shown highlighted.*

Bit	Symbol	Access	Value	Description
7 to 0	DAC_VERSION_ID[7:0]	R/W		DAC version number
			-	8 bits for the DAC version number

**Table 96. Register DIG\_VERSION (address 1Dh)***Default values are shown highlighted.*

Bit	Symbol	Access	Value	Description
7 to 0	DIG_VERSION_ID[7:0]	R/W		digital version number
			-	8 bits for the digital version number

**Table 97. Register DIG\_VERSION (address 1Eh)***Default values are shown highlighted.*

Bit	Symbol	Access	Value	Description
7 to 0	LVDS_VERSION_ID[7:0]	R/W		LVDS receiver version number
			-	8 bits for the LVDS receiver version number

**Table 98. Register PAGE\_ADD (address 1Fh)***Default values are shown highlighted.*

Bit	Symbol	Access	Value	Description
2 to 0	PAGE_ADD[2:0]	R/W		Page address
			-	current page address

11. Package outline

HVQFN72: plastic thermal enhanced very thin quad flat package; no leads; 72 terminals; body 10 x 10 x 0.85 mm

SOT813-3

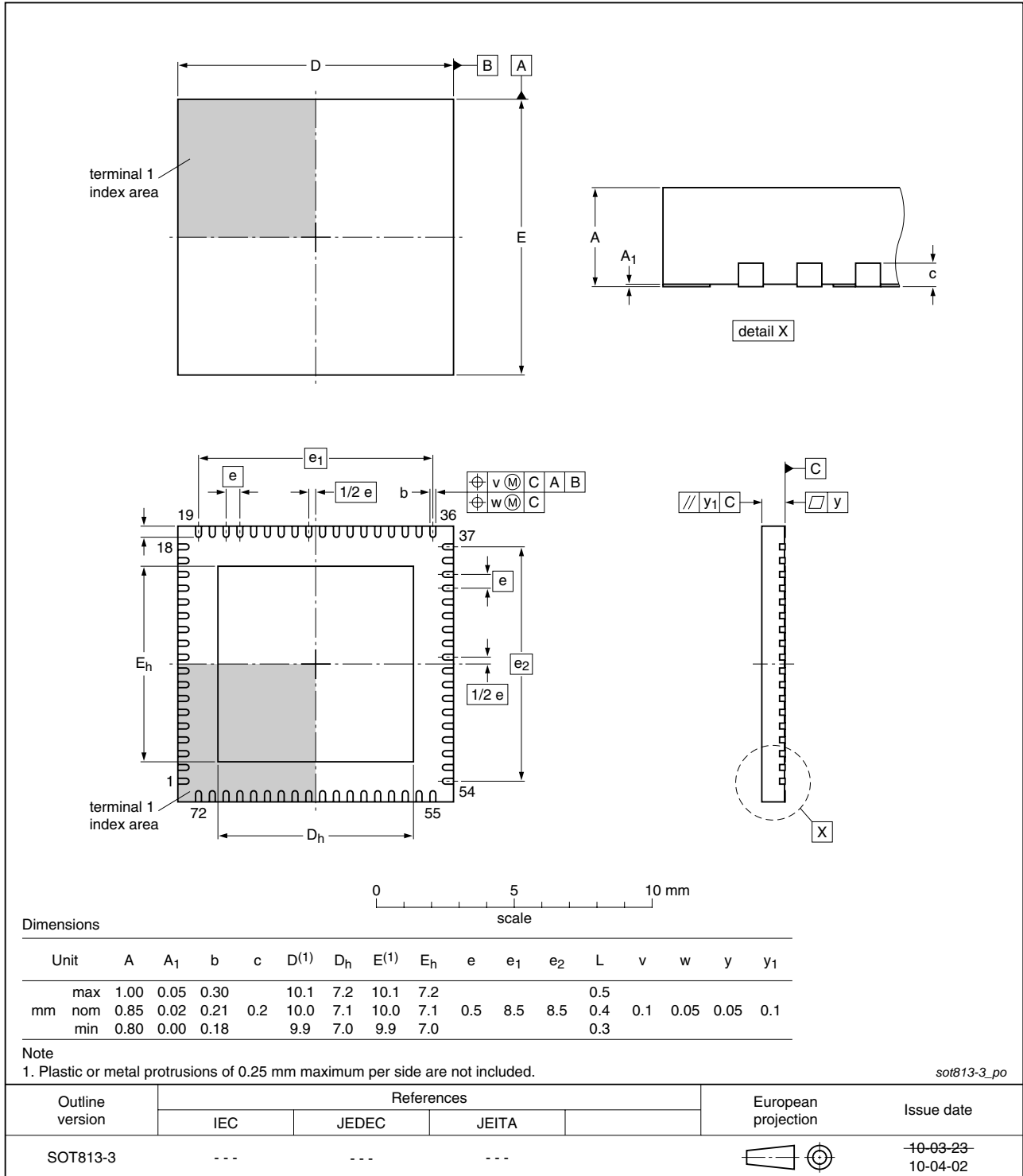

Fig 30. Package outline SOT813-3 (HVQFN72)

## 12. Abbreviations

**Table 99. Abbreviations**

Acronym	Description
BW	BandWidth
BWA	Broadband Wireless Access
CDI	Clock Domain Interface
CDMA	Code Division Multiple Access
CML	Current Mode Logic
CMOS	Complementary Metal Oxide Semiconductor
DAC	Digital-to-Analog Converter
EDGE	Enhanced Data rates for GSM Evolution
FIR	Finite Impulse Response
GSM	Global System for Mobile communications
IF	Intermediate Frequency
IMD3	Third Order InterModulation
LMDS	Local Multipoint Distribution Service
LO	Local Oscillator
LVDS	Low-Voltage Differential Signaling
NCO	Numerically Controlled Oscillator
NMOS	Negative Metal-Oxide Semiconductor
PLL	Phase-Locked Loop
SFDR	Spurious-Free Dynamic Range
SPI	Serial Peripheral Interface
WCDMA	Wide band Code Division Multiple Access
WLL	Wireless Local Loop

## 13. Glossary

---

### 13.1 Static parameters

**INL** — The deviation of the transfer function from a best fit straight line (linear regression computation).

**DNL** — The difference between the ideal and the measured output value between successive DAC codes.

### 13.2 Dynamic parameters

**Spurious-Free Dynamic Range (SFDR)** — The ratio between the RMS value of the reconstructed output sine wave and the RMS value of the largest spurious observed (harmonic and non-harmonic, excluding DC component) in the frequency domain.

**Decibels relative to full scale (dBFS)** — Unit used in a digital system in order to measure the amplitude level in decibel relative to the maximum peak value.

**InterModulation Distortion (IMD)** — From a dual-tone digital input sine wave (these two frequencies being close together), the intermodulation distortion products IMD2 and IMD3 (second order and third order components) are defined below.

**IMD2** — The ratio between the RMS value of either tone and the RMS value of the worst second order inter modulation product.

**IMD3** — The ratio between the RMS value of either tone and the RMS value of the worst third order inter modulation product.

**Total Harmonic Distortion (THD)** — The ratio between the RMS value of the harmonics of the output frequency and the RMS value of the output sine wave. Usually, the calculation of THD is done on the first 5 harmonics.

**Signal-to-Noise Ratio (SNR)** — The ratio between the RMS value of the reconstructed output sine wave and the RMS value of the noise excluding the harmonics and the DC component.

**Restricted BandWidth Spurious-Free Dynamic Range (SFDR<sub>RBW</sub>)** — the ratio between the RMS value of the reconstructed output sine wave and the RMS value of the noise, including the harmonics, in a given bandwidth centered around  $f_{\text{offset}}$ .

## 14. Revision history

Table 100. Revision history

Document ID	Release date	Data sheet status	Change notice	Supersedes
DAC1627D1G25 v.1	20110429	Objective data sheet	-	-

## 15. Legal information

### 15.1 Data sheet status

Document status <sup>[1][2]</sup>	Product status <sup>[3]</sup>	Definition
Objective [short] data sheet	Development	This document contains data from the objective specification for product development.
Preliminary [short] data sheet	Qualification	This document contains data from the preliminary specification.
Product [short] data sheet	Production	This document contains the product specification.

[1] Please consult the most recently issued document before initiating or completing a design.

[2] The term 'short data sheet' is explained in section "Definitions".

[3] The product status of device(s) described in this document may have changed since this document was published and may differ in case of multiple devices. The latest product status information is available on the Internet at URL <http://www.nxp.com>.

### 15.2 Definitions

**Draft** — The document is a draft version only. The content is still under internal review and subject to formal approval, which may result in modifications or additions. NXP Semiconductors does not give any representations or warranties as to the accuracy or completeness of information included herein and shall have no liability for the consequences of use of such information.

**Short data sheet** — A short data sheet is an extract from a full data sheet with the same product type number(s) and title. A short data sheet is intended for quick reference only and should not be relied upon to contain detailed and full information. For detailed and full information see the relevant full data sheet, which is available on request via the local NXP Semiconductors sales office. In case of any inconsistency or conflict with the short data sheet, the full data sheet shall prevail.

**Product specification** — The information and data provided in a Product data sheet shall define the specification of the product as agreed between NXP Semiconductors and its customer, unless NXP Semiconductors and customer have explicitly agreed otherwise in writing. In no event however, shall an agreement be valid in which the NXP Semiconductors product is deemed to offer functions and qualities beyond those described in the Product data sheet.

### 15.3 Disclaimers

**Limited warranty and liability** — Information in this document is believed to be accurate and reliable. However, NXP Semiconductors does not give any representations or warranties, expressed or implied, as to the accuracy or completeness of such information and shall have no liability for the consequences of use of such information.

In no event shall NXP Semiconductors be liable for any indirect, incidental, punitive, special or consequential damages (including - without limitation - lost profits, lost savings, business interruption, costs related to the removal or replacement of any products or rework charges) whether or not such damages are based on tort (including negligence), warranty, breach of contract or any other legal theory.

Notwithstanding any damages that customer might incur for any reason whatsoever, NXP Semiconductors' aggregate and cumulative liability towards customer for the products described herein shall be limited in accordance with the *Terms and conditions of commercial sale* of NXP Semiconductors.

**Right to make changes** — NXP Semiconductors reserves the right to make changes to information published in this document, including without limitation specifications and product descriptions, at any time and without notice. This document supersedes and replaces all information supplied prior to the publication hereof.

**Suitability for use** — NXP Semiconductors products are not designed, authorized or warranted to be suitable for use in life support, life-critical or safety-critical systems or equipment, nor in applications where failure or

malfunction of an NXP Semiconductors product can reasonably be expected to result in personal injury, death or severe property or environmental damage. NXP Semiconductors accepts no liability for inclusion and/or use of NXP Semiconductors products in such equipment or applications and therefore such inclusion and/or use is at the customer's own risk.

**Applications** — Applications that are described herein for any of these products are for illustrative purposes only. NXP Semiconductors makes no representation or warranty that such applications will be suitable for the specified use without further testing or modification.

Customers are responsible for the design and operation of their applications and products using NXP Semiconductors products, and NXP Semiconductors accepts no liability for any assistance with applications or customer product design. It is customer's sole responsibility to determine whether the NXP Semiconductors product is suitable and fit for the customer's applications and products planned, as well as for the planned application and use of customer's third party customer(s). Customers should provide appropriate design and operating safeguards to minimize the risks associated with their applications and products.

NXP Semiconductors does not accept any liability related to any default, damage, costs or problem which is based on any weakness or default in the customer's applications or products, or the application or use by customer's third party customer(s). Customer is responsible for doing all necessary testing for the customer's applications and products using NXP Semiconductors products in order to avoid a default of the applications and the products or of the application or use by customer's third party customer(s). NXP does not accept any liability in this respect.

**Limiting values** — Stress above one or more limiting values (as defined in the Absolute Maximum Ratings System of IEC 60134) will cause permanent damage to the device. Limiting values are stress ratings only and (proper) operation of the device at these or any other conditions above those given in the Recommended operating conditions section (if present) or the Characteristics sections of this document is not warranted. Constant or repeated exposure to limiting values will permanently and irreversibly affect the quality and reliability of the device.

**Terms and conditions of commercial sale** — NXP Semiconductors products are sold subject to the general terms and conditions of commercial sale, as published at <http://www.nxp.com/profile/terms>, unless otherwise agreed in a valid written individual agreement. In case an individual agreement is concluded only the terms and conditions of the respective agreement shall apply. NXP Semiconductors hereby expressly objects to applying the customer's general terms and conditions with regard to the purchase of NXP Semiconductors products by customer.

**No offer to sell or license** — Nothing in this document may be interpreted or construed as an offer to sell products that is open for acceptance or the grant, conveyance or implication of any license under any copyrights, patents or other industrial or intellectual property rights.

**Export control** — This document as well as the item(s) described herein may be subject to export control regulations. Export might require a prior authorization from national authorities.

**Non-automotive qualified products** — Unless this data sheet expressly states that this specific NXP Semiconductors product is automotive qualified, the product is not suitable for automotive use. It is neither qualified nor tested in accordance with automotive testing or application requirements. NXP Semiconductors accepts no liability for inclusion and/or use of non-automotive qualified products in automotive equipment or applications.

In the event that customer uses the product for design-in and use in automotive applications to automotive specifications and standards, customer (a) shall use the product without NXP Semiconductors' warranty of the product for such automotive applications, use and specifications, and (b) whenever customer uses the product for automotive applications beyond

NXP Semiconductors' specifications such use shall be solely at customer's own risk, and (c) customer fully indemnifies NXP Semiconductors for any liability, damages or failed product claims resulting from customer design and use of the product for automotive applications beyond NXP Semiconductors' standard warranty and NXP Semiconductors' product specifications.

## 15.4 Trademarks

Notice: All referenced brands, product names, service names and trademarks are the property of their respective owners.

## 16. Contact information

For more information, please visit: <http://www.nxp.com>

For sales office addresses, please send an email to: [salesaddresses@nxp.com](mailto:salesaddresses@nxp.com)

17. Tables

Table 1. Ordering information	2	(address 13h)	44
Table 2. Pin description	4	Table 43. Register DAC_B_OFFSET_MSB	44
Table 3. Limiting values	6	(address 14h)	44
Table 4. Thermal characteristics	7	Table 44. Register PHINCO_LSB (address 15h)	44
Table 5. Characteristics	8	Table 45. Register PHINCO_MSB (address 16h)	44
Table 6. Read or Write mode access description	13	Table 46. Register DAC_A_GAIN1 (address 17h)	44
Table 7. Number of bytes to be transferred	13	Table 47. Register DAC_A_GAIN2 (address 18h)	44
Table 8. SPI timing characteristics	14	Table 48. Register DAC_B_GAIN1 (address 19h)	44
Table 9. Input LVDS bus swapping	16	Table 49. Register DAC_B_GAIN2 (address 1Ah)	45
Table 10. Folded and interleaved format mapping	17	Table 50. DAC_A_Aux_MSB register (address 1Bh)	45
Table 11. Compensation delay values for manual tuning	21	bit description	45
Table 12. CDI mode 0: operating modes examples	22	Table 51. DAC_A_Aux_LSB register (address 1Ch)	45
Table 13. CDI mode 1: operating modes examples	22	bit description	45
Table 14. CDI mode 2: operating modes examples	23	Table 52. DAC_B_Aux_MSB register (address 1Dh)	45
Table 15. Interpolation filter coefficients	24	bit description	45
Table 16. Complex modulator operation mode	26	Table 53. DAC_B_Aux_LSB register (address 1Eh)	45
Table 17. Inversion filter coefficients	27	bit description	45
Table 18. DAC transfer function	28	Table 54. SPI_PAGE register (address 1Fh)	45
Table 19. I <sub>O(fs)</sub> coarse adjustment	29	bit description	45
Table 20. I <sub>O(fs)</sub> fine adjustment	29	Table 55. Page 1 register allocation map	46
Table 21. Digital offset adjustment	30	Table 56. MDS_MAIN register (address 00h)	48
Table 22. Auxiliary DAC transfer function	31	bit description	48
Table 23. Page_00 register allocation map	38	Table 57. MDS_WIN_PERIOD_A register (address 01h)	48
Table 24. Register COMMON (address 00h)	40	bit description	48
bit description	40	Table 58. MDS_WIN_PERIOD_B register (address 02h)	48
Table 25. Register TXCFG (address 01h)	40	bit description	48
bit description	40	Table 59. MDS_MISCCNTRL0 register (address 03h)	48
Table 26. Register PLLCFG (address 02h)	41	bit description	48
bit description	41	Table 60. MDS_MAN_ADJUSTDLY register (address 04h)	49
Table 27. Register FREQNCO_B0 (address 04h)	41	bit description	49
Table 28. Register FREQNCO_B1 (address 05h)	42	Table 61. MDS_AUTO_CYCLES register (address 05h)	49
Table 29. Register FREQNCO_B2 (address 06h)	42	bit description	49
Table 30. Register FREQNCO_B3 (address 07h)	42	Table 62. MDS_MISCCNTRL1 register (address 06h)	49
Table 31. Register FREQNCO_B4 (address 08h)	42	bit description	49
Table 32. Register PH_CORR_CTL0 (address 09h)	42	Table 63. MDS_OFFSET_DLY register (address 07h)	50
Table 33. Register PH_CORR_CTL1 (address 0Ah)	42	bit description	50
Table 34. Register DAC_A_DGAIN_LSB (address 0Bh)	42	Table 64. MDS_ADJDELAY register (address 08h)	50
Table 35. Register DAC_A_DGAIN_MSB (address 0Ch)	43	bit description	50
Table 36. Register DAC_B_DGAIN_LSB (address 0Dh)	43	Table 65. MDS_STATUS0 register (address 09h)	50
Table 37. Register DAC_B_DGAIN_MSB (address 0Eh)	43	bit description	50
Table 38. Register DAC_OUT_CTRL (address 0Fh)	43	Table 66. MDS_STATUS1 register (address 0Ah)	50
Table 39. Register DAC_CLIPPING (address 10h)	43	bit description	50
Table 40. Register DAC_A_OFFSET_LSB (address 11h)	43	Table 67. DAC_CURRENT_AUX register (address 0Eh)	51
Table 41. Register DAC_A_OFFSET_MSB (address 12h)	44	bit description	51
Table 42. Register DAC_B_OFFSET_LSB (address 13h)	44	Table 68. DAC_CURRENT_0 register (address 0Fh)	51
		bit description	51
		Table 69. DAC_CURRENT_1 register (address 10h)	51
		bit description	51

continued >>

Table 70. DAC\_CURRENT\_2 register (address 11h)  
 bit description .....51

Table 71. DAC\_CURRENT\_3 register (address 12h)  
 bit description .....51

Table 72. DAC\_CURRENT\_4 register (address 13h)  
 bit description .....52

Table 73. DAC\_CURRENT\_5 register (address 14h)  
 bit description .....52

Table 74. DAC\_CURRENT\_6 register (address 15h)  
 bit description .....52

Table 75. Bias current control table .....52

Table 76. DAC\_PON\_SLEEP register (address 16h)  
 bit description .....52

Table 77. DAC\_TEST\_8 register (address 17h)  
 bit description .....53

Table 78. SPI\_PAGE register (address 1Fh)  
 bit description .....53

Table 79. Page\_0A register allocation map .....54

Table 80. Register MAIN\_CNTRL (address 00h) .....56

Table 81. Register MAN\_LDCLKDEL (address 01h) .....56

Table 82. Register DBG\_LVDS (address 02h) .....56

Table 83. Register RST\_EXT\_LCLK (address 04h) .....56

Table 84. Register RST\_EXT\_DCLK (address 05h) .....57

Table 85. Register DCSMU\_PREDIV (address 06h) .....57

Table 86. Register LD\_POL\_LSB (address 08h) .....57

Table 87. Register LD\_POL\_MSB (address 09h) .....57

Table 88. Register LD\_CNTRL (address 0Ah) .....57

Table 89. Register MISC\_CNTRL (address 0Bh) .....58

Table 90. Register I\_DC\_LVL\_LSB(address 0Ch) .....59

Table 91. Register I\_DC\_LVL\_MSB(address 0Dh) .....59

Table 92. Register Q\_DC\_LVL\_LSB(address 0Eh) .....59

Table 93. Register Q\_DC\_LVL\_MSB(address 0Fh) .....59

Table 94. Register TYPE\_ID (address 1Bh) .....59

Table 95. Register DAC\_VERSION (address 1Ch) .....60

Table 96. Register DIG\_VERSION (address 1Dh) .....60

Table 97. Register DIG\_VERSION (address 1Eh) .....60

Table 98. Register PAGE\_ADD (address 1Fh) .....60

Table 99. Abbreviations .....62

Table 100. Revision history .....64

## 18. Contents

<b>1</b>	<b>General description</b> . . . . .	<b>1</b>	10.16.2	IQ-modulator - BGX7100 interface	33
<b>2</b>	<b>Features and benefits</b> . . . . .	<b>2</b>	10.16.3	IQ-modulator - DC interface	33
<b>3</b>	<b>Applications</b> . . . . .	<b>2</b>	10.16.4	IQ-modulator - AC interface	36
<b>4</b>	<b>Ordering information</b> . . . . .	<b>2</b>	10.17	Design recommendations	36
<b>5</b>	<b>Block diagram</b> . . . . .	<b>3</b>	10.17.1	Power and grounding	36
<b>6</b>	<b>Pinning information</b> . . . . .	<b>4</b>	10.18	Configuration interface	37
6.1	Pinning . . . . .	4	10.18.1	Register description	37
6.2	Pin description . . . . .	4	10.18.2	Page 0 register allocation map	38
<b>7</b>	<b>Limiting values</b> . . . . .	<b>6</b>	10.18.3	Page 0 bit definition detailed description	40
<b>8</b>	<b>Thermal characteristics</b> . . . . .	<b>7</b>	10.18.4	Page 1 allocation map	46
<b>9</b>	<b>Characteristics</b> . . . . .	<b>8</b>	10.18.5	Page 1 bit definition detailed description	48
<b>10</b>	<b>Application information</b> . . . . .	<b>12</b>	10.18.6	Page A register allocation map	54
10.1	General description . . . . .	12	10.18.7	Page A bit definition detailed description	56
10.2	Serial Peripheral Interface (SPI) . . . . .	13	<b>11</b>	<b>Package outline</b> . . . . .	<b>61</b>
10.2.1	Protocol description . . . . .	13	<b>12</b>	<b>Abbreviations</b> . . . . .	<b>62</b>
10.2.2	SPI timing description . . . . .	14	<b>13</b>	<b>Glossary</b> . . . . .	<b>63</b>
10.3	Power-on sequence . . . . .	14	13.1	Static parameters . . . . .	63
10.4	LVDS Data Input Format (DIF) block . . . . .	15	13.2	Dynamic parameters . . . . .	63
10.4.1	Input port polarity . . . . .	15	<b>14</b>	<b>Revision history</b> . . . . .	<b>64</b>
10.4.2	Input port mapping . . . . .	16	<b>15</b>	<b>Legal information</b> . . . . .	<b>65</b>
10.4.3	Input port swapping . . . . .	16	15.1	Data sheet status . . . . .	65
10.4.4	Input port formatting . . . . .	17	15.2	Definitions . . . . .	65
10.5	Input clock . . . . .	18	15.3	Disclaimers . . . . .	65
10.5.1	LVDS DDR clock . . . . .	18	15.4	Trademarks . . . . .	66
10.5.2	DAC core clock . . . . .	18	<b>16</b>	<b>Contact information</b> . . . . .	<b>66</b>
10.6	Timing . . . . .	19	<b>17</b>	<b>Tables</b> . . . . .	<b>67</b>
10.7	Operating modes . . . . .	21	<b>18</b>	<b>Contents</b> . . . . .	<b>69</b>
10.7.1	CDI mode 0 (x2 interpolation) . . . . .	22			
10.7.2	CDI mode 1 (x4 interpolation) . . . . .	22			
10.7.3	CDI mode 2 (x8 interpolation) . . . . .	23			
10.8	FIR filters . . . . .	23			
10.9	Single SideBand Modulator (SSBM) . . . . .	25			
10.9.1	NCO in 40 bits . . . . .	25			
10.9.2	NCO low power . . . . .	26			
10.9.3	Complex modulator . . . . .	26			
10.9.4	Minus 3dB . . . . .	27			
10.10	Inverse $\sin x / x$ . . . . .	27			
10.11	DAC transfer function . . . . .	27			
10.12	Full-scale current . . . . .	28			
10.12.1	Regulation . . . . .	28			
10.12.2	Full-scale current adjustment . . . . .	28			
10.13	Digital offset adjustment . . . . .	29			
10.14	Analog output . . . . .	30			
10.15	Auxiliary DACs . . . . .	31			
10.16	Output configuration . . . . .	32			
10.16.1	Basic output configuration . . . . .	32			

Please be aware that important notices concerning this document and the product(s) described herein, have been included in section 'Legal information'.

© NXP B.V. 2011.

All rights reserved.

For more information, please visit: <http://www.nxp.com>

For sales office addresses, please send an email to: [salesaddresses@nxp.com](mailto:salesaddresses@nxp.com)

Date of release: 29 April 2011

Document identifier: DAC1627D1G25