

DAC1008D750

Dual 10-bit DAC; up to 750 Msps; 2×, 4× or 8× interpolating with JESD204A interface

Rev. 3 — 31 January 2012

Product data sheet

1. General description

The DAC1008D750 is a high-speed 10-bit dual channel Digital-to-Analog Converter (DAC) with selectable 2×, 4× or 8× interpolating filters optimized for multi-carrier WCDMA transmitters.

Because of its digital on-chip modulation, the DAC1008D750 allows the complex pattern provided through lane 0, lane 1, lane 2 and lane 3, to be converted up from baseband to IF. The mixing frequency is adjusted via a Serial Peripheral Interface (SPI) with a 32-bit Numerically Controlled Oscillator (NCO) and the phase is controlled by a 16-bit register.

The DAC1008D750 also includes a 2×, 4× or 8× clock multiplier which provides the appropriate internal clocks and an internal regulation to adjust the output full-scale current.

The input data format is serial according to JESD204A specification. This new interface has numerous advantages over the traditional parallel one: easy PCB layout, lower radiated noise, lower pin count, self-synchronous link, skew compensation. The maximum number of lanes of the DAC1008D750 is 4 and its maximum serial data rate is 3.125 Gbps.

The Multiple Device Synchronization (MDS) guarantees a maximum skew of one output clock period between several DAC devices. MDS incorporates modes: Master/slave and All slave mode.

2. Features and benefits

- Dual 10-bit resolution
- 750 Msps maximum update rate
- Selectable 2×, 4× or 8× interpolation filters
- Input data rate up to 312.5 Msps
- Very low-noise cap-free integrated PLL
- 32-bit programmable NCO frequency
- Four JESD204A serial input lanes
- 1.8 V and 3.3 V power supplies
- LVDS compatible clock inputs
- IMD3: 80 dBc; $f_s = 737.28$ Msps; $f_o = 140$ MHz
- ACPR: 64 dBc; two carriers WCDMA; $f_s = 737.28$ Msps; $f_o = 153.6$ MHz
- Typical 1.26 W power dissipation at 4× interpolation, PLL off and 740 Msps
- Power-down mode and Sleep modes
- Differential scalable output current from 1.6 mA to 22 mA
- On-chip 1.29 V reference
- External analog offset control (10-bit auxiliary DACs)
- Internal digital offset control
- Inverse (sin x) / x function



- Two's complement or binary offset data format
- LMF = 421 or LMF = 211 support
- Differential CML receiver with embedded termination
- Synchronization of multiple DAC outputs
- Fully compatible SPI port
- Industrial temperature range from -40 °C to +85 °C
- Integrated PLL can be bypassed
- Embedded complex modulator

3. Applications

- Wireless infrastructure: LTE, WiMAX, GSM, CDMA, WCDMA, TD-SCDMA
- Communication: LMDS/MMDS, point-to-point
- Direct Digital Synthesis (DDS)
- Broadband wireless systems
- Digital radio links
- Instrumentation
- Automated Test Equipment (ATE)

4. Ordering information

Table 1. Ordering information

Type number	Package		
	Name	Description	Version
DAC1008D750HN	HVQFN64	plastic thermal enhanced very thin quad flat package; no leads; 64 terminals; body 9 × 9 × 0.85 mm	SOT804-3

5. Block diagram

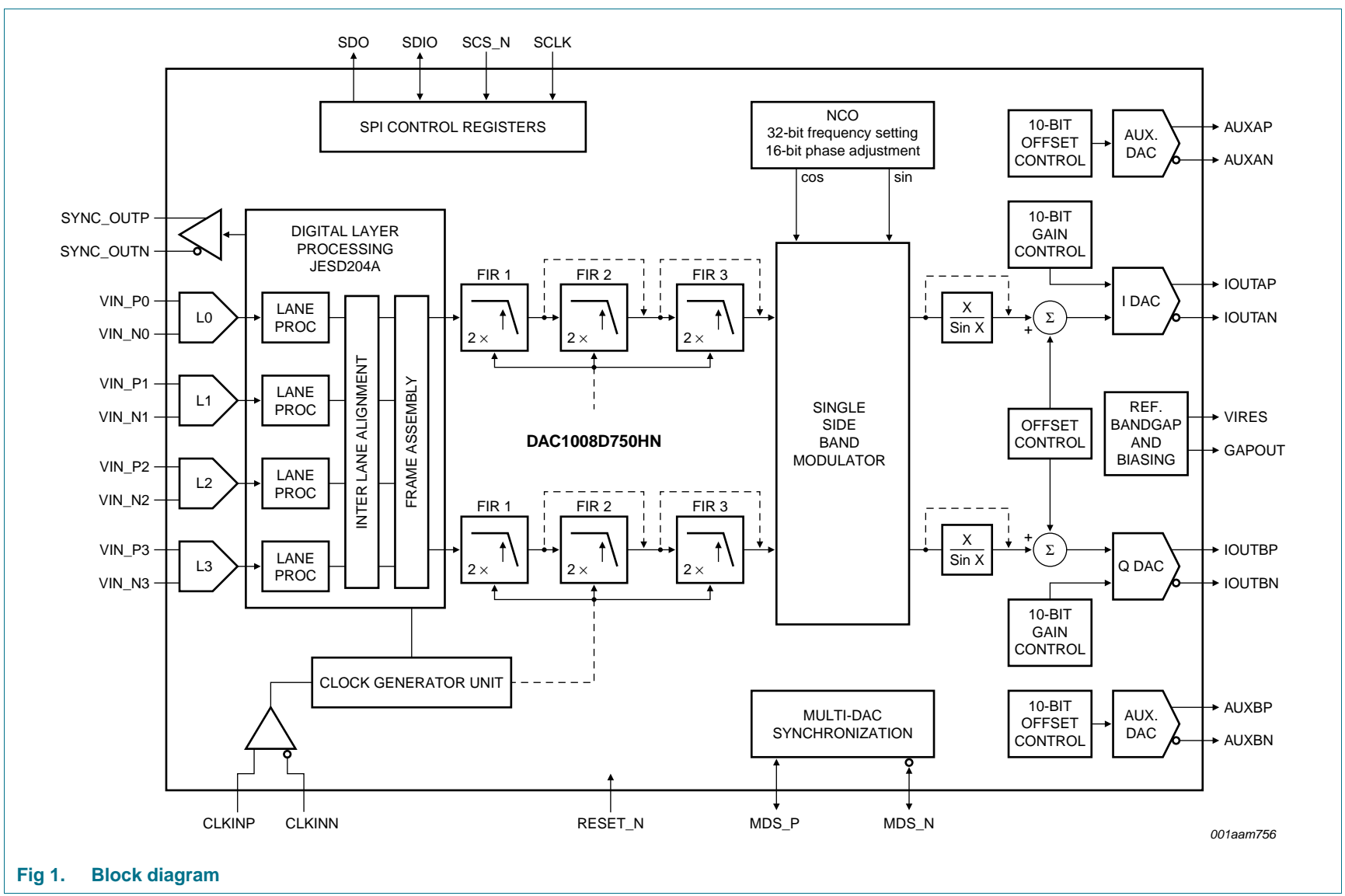

Fig 1. Block diagram

6. Pinning information

6.1 Pinning

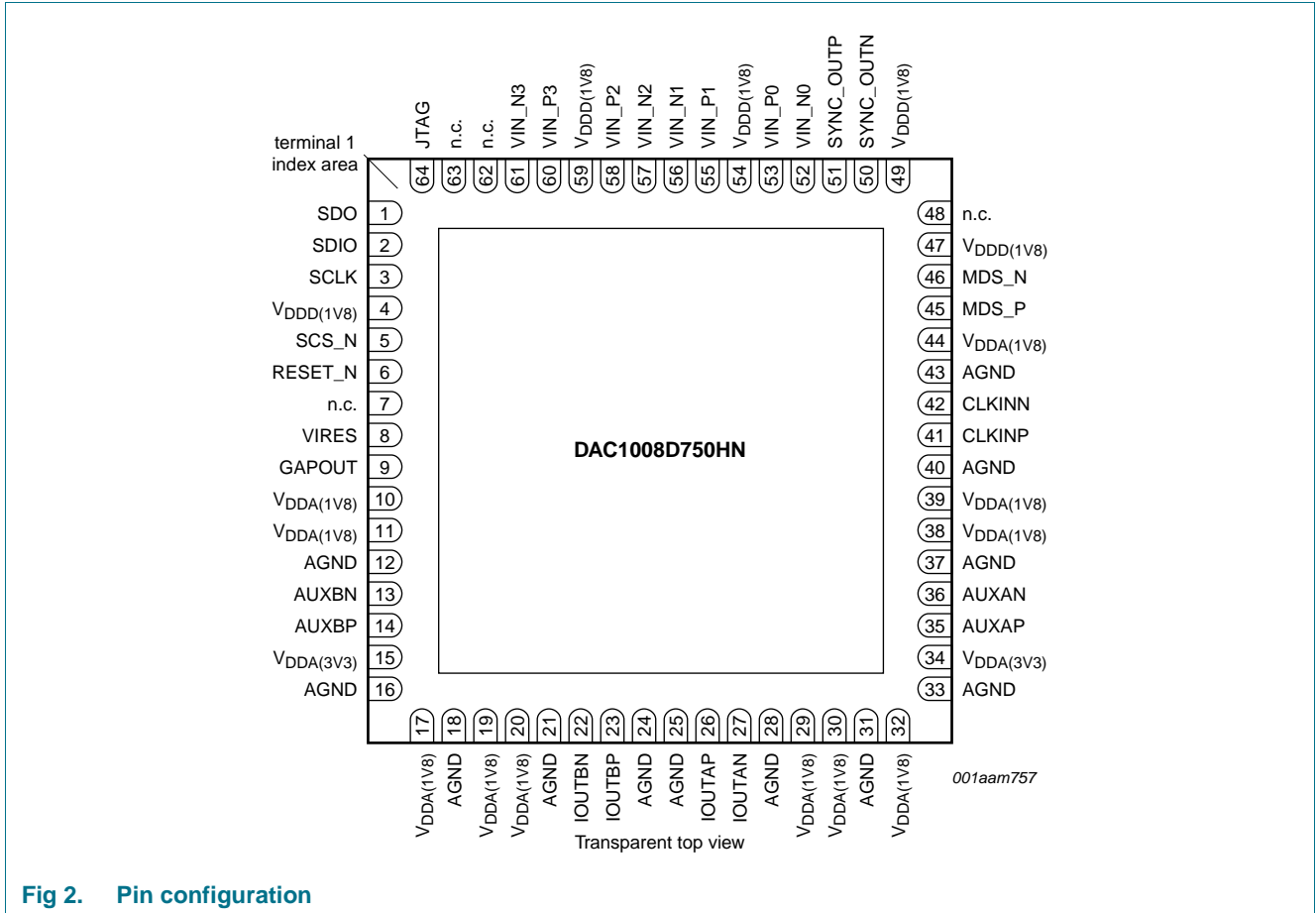

Fig 2. Pin configuration

6.2 Pin description

Table 2. Pin description

Symbol	Pin	Type ^[1]	Description
SDO	1	O	SPI data output
SDIO	2	I/O	SPI data input/output
SCLK	3	I	SPI clock
V _{DD} (1V8)	4	P	digital supply voltage 1.8 V
SCS_N	5	I	SPI chip select (active LOW)
RESET_N	6	I	general reset (active LOW)
n.c.	7	-	not connected
VIRES	8	I/O	DAC biasing resistor
GAPOUT	9	I/O	bandgap input/output voltage
V _{DDA} (1V8)	10	P	analog supply voltage 1.8 V
V _{DDA} (1V8)	11	P	analog supply voltage 1.8 V

Table 2. Pin description ...continued

Symbol	Pin	Type ^[1]	Description
AGND	12	G	analog ground
AUXBN	13	O	complementary auxiliary DAC B output
AUXBP	14	O	auxiliary DAC B output
V _{DDA(3V3)}	15	P	analog supply voltage 3.3 V
AGND	16	G	analog ground
V _{DDA(1V8)}	17	P	analog supply voltage 1.8 V
AGND	18	G	analog ground
V _{DDA(1V8)}	19	P	analog supply voltage 1.8 V
V _{DDA(1V8)}	20	P	analog supply voltage 1.8 V
AGND	21	G	analog ground
IOUTBN	22	O	complementary DAC B output current
IOUTBP	23	O	DAC B output current
AGND	24	G	analog ground
AGND	25	G	analog ground
IOUTAP	26	O	DAC A output current
IOUTAN	27	O	complementary DAC A output current
AGND	28	G	analog ground
V _{DDA(1V8)}	29	P	analog supply voltage 1.8 V
V _{DDA(1V8)}	30	P	analog supply voltage 1.8 V
AGND	31	G	analog ground
V _{DDA(1V8)}	32	P	analog supply voltage 1.8 V
AGND	33	G	analog ground
V _{DDA(3V3)}	34	P	analog supply voltage 3.3 V
AUXAP	35	O	auxiliary DAC A output current
AUXAN	36	O	complementary auxiliary DAC A output current
AGND	37	G	analog ground
V _{DDA(1V8)}	38	P	analog supply voltage 1.8 V
V _{DDA(1V8)}	39	P	analog supply voltage 1.8 V
AGND	40	G	analog ground
CLKINP	41	I	clock input
CLKINN	42	I	complementary clock input
AGND	43	G	analog ground
V _{DDA(1V8)}	44	P	analog supply voltage 1.8 V
MDS_P	45	I/O	multi-device synchronization
MDS_N	46	I/O	complementary multi-device synchronization
V _{DDD(1V8)}	47	P	digital supply voltage 1.8 V
n.c.	48	-	not connected
V _{DDD(1V8)}	49	P	digital supply voltage 1.8 V
SYNC_OUTN	50	O	synchronization request to transmitter, complementary output
SYNC_OUTP	51	O	synchronization request to transmitter

Table 2. Pin description ...continued

Symbol	Pin	Type ^[1]	Description
VIN_N0	52	I	serial interface lane 0 negative input
VIN_P0	53	I	serial interface lane 0 positive input
V _{DDD(1V8)}	54	P	digital supply voltage 1.8 V
VIN_P1	55	I	serial interface lane 1 positive input
VIN_N1	56	I	serial interface lane 1 negative input
VIN_N2	57	I	serial interface lane 2 negative input
VIN_P2	58	I	serial interface lane 2 positive input
V _{DDD(1V8)}	59	P	digital supply voltage 1.8 V
VIN_P3	60	I	serial interface lane 3 positive input
VIN_N3	61	I	serial interface lane 3 negative input
n.c.	62	-	not connected
n.c.	63	-	not connected
JTAG	64	I	JTAG test mode select (must be grounded)
GND	H ^[2]	G	ground

[1] P: power supply; G: ground; I: input; O: output.

[2] H = heatsink (exposed die pad to be soldered to GND. A minimum of 81 thermal vias are required).

7. Limiting values

Table 3. Limiting values

In accordance with the Absolute Maximum Rating System (IEC 60134).

Symbol	Parameter	Conditions	Min	Max	Unit
V _{DDA(3V3)}	analog supply voltage (3.3 V)		-0.5	+4.6	V
V _{DDA(1V8)}	analog supply voltage (1.8 V)		-0.5	+2.5	V
V _{DDD}	digital supply voltage		-0.5	+2.5	V
T _{stg}	storage temperature		-55	+150	°C
T _{amb}	ambient temperature		-40	+85	°C
T _j	junction temperature		-40	+125	°C

8. Thermal characteristics

Table 4. Thermal characteristics

Symbol	Parameter	Conditions	Typ	Unit
R _{th(j-a)}	thermal resistance from junction to ambient		^[1] 18.7	K/W
R _{th(j-c)}	thermal resistance from junction to case		^[1] 6.7	K/W

[1] Complies with JEDEC test board, in free air.

9. Characteristics

Table 5. Characteristics

$V_{DDA(1V8)} = V_{DDD} = 1.7\text{ V to }1.9\text{ V}$; $V_{DDA(3V3)} = 3.13\text{ V to }3.47\text{ V}$; AGND and GND are shorted together; $T_{amb} = -40\text{ °C to }+85\text{ °C}$; typical values measured at $V_{DDA(1V8)} = V_{DDD} = 1.8\text{ V}$; $V_{DDA(3V3)} = 3.3\text{ V}$; $T_{amb} = +25\text{ °C}$; $R_L = 50\text{ }\Omega$; $I_{O(fs)} = 20\text{ mA}$; maximum sample rate; PLL off unless otherwise specified.

Symbol	Parameter	Conditions	Test ^[1]	Min	Typ	Max	Unit	
$V_{DDA(3V3)}$	analog supply voltage (3.3 V)		I	3.13	3.3	3.47	V	
$V_{DDD(1V8)}$	digital supply voltage (1.8 V)		I	1.7	1.8	1.9	V	
$V_{DDA(1V8)}$	analog supply voltage (1.8 V)		I	1.7	1.8	1.9	V	
$I_{DDA(3V3)}$	analog supply current (3.3 V)	$f_o = 19\text{ MHz}$; $f_s = 740\text{ Msps}$; 4× interpolation; NCO on	I	-	41	-	mA	
$I_{DDD(1V8)}$	digital supply current, (1.8 V)	$f_o = 19\text{ MHz}$; $f_s = 740\text{ Msps}$; 4× interpolation; NCO on	I	-	356	-	mA	
$I_{DDA(1V8)}$	analog supply current, (1.8 V)	$f_o = 19\text{ MHz}$; $f_s = 740\text{ Msps}$; 4× interpolation; NCO on	I	-	421	-	mA	
ΔI_{DDD}	digital supply current difference	x/sin x function on; $f_s = 740\text{ Msps}$	I	-	54	-	mA	
P_{tot}	total power dissipation	$f_s = 740\text{ Msps}$; 4× interpolation; NCO off; DAC Q off	C	-	0.80	-	W	
		$f_s = 740\text{ Msps}$; 4× interpolation; NCO off	C	-	1.26	-	W	
		$f_s = 740\text{ Msps}$; 4× interpolation; NCO on	C	-	1.50	-	W	
		$f_s = 625\text{ Msps}$; 2× interpolation; NCO off	C	-	1.29	-	W	
		$f_s = 625\text{ Msps}$; 2× interpolation; NCO on	C	-	1.46	-	W	
		Power-down mode; $f_o = 19\text{ MHz}$; $f_s = 740\text{ Msps}$; 4× interpolation; NCO on						
		complete device; Power-down mode	I	-	0.04	-	W	
		DAC A and DAC B; Power-down mode	I	-	0.60	-	W	
		DAC A and DAC B; Sleep mode	I	-	0.80	-	W	

Timing specifications

$t_{d(startup)}$	start-up delay time	from full Power-down mode		-	20	-	ms
$t_{d(restart)}$	restart delay time	from Sleep mode		-	300	-	ns
t_{lock}	lock time	maximum input rate	^[2]	-	11	-	μs

Table 5. Characteristics ...continued

$V_{DDA(1V8)} = V_{DDD} = 1.7\text{ V to }1.9\text{ V}$; $V_{DDA(3V3)} = 3.13\text{ V to }3.47\text{ V}$; AGND and GND are shorted together; $T_{amb} = -40\text{ °C to }+85\text{ °C}$; typical values measured at $V_{DDA(1V8)} = V_{DDD} = 1.8\text{ V}$; $V_{DDA(3V3)} = 3.3\text{ V}$; $T_{amb} = +25\text{ °C}$; $R_L = 50\ \Omega$; $I_{O(fs)} = 20\text{ mA}$; maximum sample rate; PLL off unless otherwise specified.

Symbol	Parameter	Conditions	Test ^[1]	Min	Typ	Max	Unit
Clock inputs (CLKINN, CLKINP)^[3]							
V_i	input voltage	range: CLK+ or CLK– $ V_{gpd} < 50\text{ mV}$ ^[4]	C	825	-	1575	mV
V_{idth}	input differential threshold voltage	$ V_{gpd} < 50\text{ mV}$ ^[4]	C	-100	-	+100	mV
R_i	input resistance		D	-	10	-	M Ω
C_i	input capacitance		D	-	0.5	-	pF
Digital inputs (SDO, SDIO, SCLK, SCS_N, RESET_N)							
V_{IL}	LOW-level input voltage		C	GND	-	$0.3V_{DDD}$	V
V_{IH}	HIGH-level input voltage		C	$0.7V_{DDD}$	-	V_{DDD}	V
I_{IL}	LOW-level input current	$V_{IL} = 0.3V_{DDD}\text{ V}$	I	-	1	-	μA
I_{IH}	HIGH-level input current	$V_{IH} = 0.7V_{DDD}\text{ V}$	I	-	1	-	μA
Digital outputs (SDO, SDIO)							
V_{OL}	LOW-level output voltage	$I_{load} = 2\text{ mA}$	C	GND	-	0.13	V
V_{OH}	HIGH-level output voltage	$I_{load} = 2\text{ mA}$	C	1.65	-	V_{DDD}	V
Digital inputs (V_{in_p}/V_{in_n})^[5]							
$V_{I(cm)}$	common-mode input voltage		D	-	0.78	-	V
$V_{I(dif)(p-p)}$	peak-to-peak differential input voltage		D	175	-	1000	mV
Z_{tt}	V_{tt} source impedance		D	-	0.7	-	Ω
ΔZ_i	differential input impedance		D	-	100	-	Ω
Digital outputs (SYNC_OUTN/SYNC_OUTP)^[6]							
$V_{o(cm)}$	common-mode output voltage		C	-	1.18	-	V
$V_{o(dif)(p-p)}$	peak-to-peak differential output voltage		C	-	0.45	-	V
Digital inputs/outputs (MDS_N/MDS_P)							
$V_{o(dif)(p-p)}$	peak-to-peak differential output voltage		D	-	600	-	mV
$C_{o(L)}$	Output load capacitance	between pins GND and MDS_N or MDS_P	D	-	-	10	pF
C_i	Input capacitance	between pins GND and MDS_N or MDS_P	D	-	0.3	-	pF

Table 5. Characteristics ...continued

$V_{DDA(1V8)} = V_{DDD} = 1.7\text{ V to }1.9\text{ V}$; $V_{DDA(3V3)} = 3.13\text{ V to }3.47\text{ V}$; AGND and GND are shorted together; $T_{amb} = -40\text{ °C to }+85\text{ °C}$; typical values measured at $V_{DDA(1V8)} = V_{DDD} = 1.8\text{ V}$; $V_{DDA(3V3)} = 3.3\text{ V}$; $T_{amb} = +25\text{ °C}$; $R_L = 50\ \Omega$; $I_{O(fs)} = 20\text{ mA}$; maximum sample rate; PLL off unless otherwise specified.

Symbol	Parameter	Conditions	Test ^[1]	Min	Typ	Max	Unit
Analog outputs (IOUTAP, IOUTAN, IOUTBP, IOUTBN)							
$I_{O(fs)}$	full-scale output current	register value = 00h (see Table 13 and Table 14)	D	-	1.6	-	mA
		register = default value (see Table 13 and Table 14)		-	20	-	mA
V_O	output voltage	compliance range	D	1.8	-	$V_{DDA(3V3)}$	V
R_o	output resistance		D	-	250	-	k Ω
C_o	output capacitance		D	-	3	-	pF
ΔE_O	offset error variation		D	-	6	-	ppm/°C
ΔE_G	gain error variation		D	-	18	-	ppm/°C
Reference voltage output (GAPOUT)							
$V_{O(ref)}$	reference output voltage		C	1.24	1.29	1.34	V
$I_{O(ref)}$	reference output current	external voltage 1.2 V	C	-	40	-	μ A
$\Delta V_{O(ref)}$	reference output voltage variation		C	-	117	-	ppm/°C
Analog auxiliary outputs (AUXAP, AUXAN, AUXBP and AUXBN)							
$I_{O(aux)}$	auxiliary output current	differential outputs	I	-	2.2	-	mA
$V_{O(aux)}$	auxiliary output voltage	compliance range	D	0	-	2	V
$N_{DAC(aux)mono}$	auxiliary DAC monotonicity	guaranteed	D	-	10	-	bits
Input timing (V_{in_p}/V_{in_n})							
f_{data}	data rate	2× interpolation	D	-	-	312.5	MspS
		4× interpolation	D	-	-	187.5	MspS
		8× interpolation	D	-	-	93.75	MspS
f_{bit}	bit rate	serial input	D	0.7	-	3.125	Gbps
Output timing (IOUTAP, IOUTAN, IOUTBP, IOUTBN)							
f_s	sampling rate		D	-	-	750	MspS
t_s	settling time	up to 0.5 LSB	D	-	20	-	ns
NCO frequency range; $f_s = 750\text{ MspS}$							
f_{NCO}	NCO frequency	register value = 00000000h (see Table 21 to Table 24)	D	-	0	-	MHz
		register value = FFFFFFFFh (see Table 21 to Table 24)	D	-	750	-	MHz
f_{step}	step frequency		D	-	0.175	-	Hz
Low power NCO frequency range; $f_s = 750\text{ MspS}$							
f_{NCO}	NCO frequency	reg value = 00000000h (see Table 21 to Table 24)	D	-	0	-	MHz
		reg value = F8000000h (see Table 21 to Table 24)	D	-	726.4	-	MHz

Table 5. Characteristics ...continued

$V_{DDA(1V8)} = V_{DDD} = 1.7\text{ V to }1.9\text{ V}$; $V_{DDA(3V3)} = 3.13\text{ V to }3.47\text{ V}$; AGND and GND are shorted together; $T_{amb} = -40\text{ °C to }+85\text{ °C}$; typical values measured at $V_{DDA(1V8)} = V_{DDD} = 1.8\text{ V}$; $V_{DDA(3V3)} = 3.3\text{ V}$; $T_{amb} = +25\text{ °C}$; $R_L = 50\ \Omega$; $I_{O(fs)} = 20\text{ mA}$; maximum sample rate; PLL off unless otherwise specified.

Symbol	Parameter	Conditions	Test ^[1]	Min	Typ	Max	Unit	
f_{step}	step frequency		D	-	23.4	-	MHz	
Dynamic performances								
SFDR	spurious-free dynamic range	$f_{data} = 92.16\text{ Msps}$; $f_s = 737.28\text{ Msps}$; 8×; BW = $f_{data} / 2$; PLL on		[7]				
		$f_o = 4\text{ MHz at }-1\text{ dBFS}$	C	-	77	-	dBc	
		$f_{data} = 184.32\text{ Msps}$; $f_s = 737.28\text{ Msps}$; 4×; BW = $f_{data} / 2$		[7]				
		$f_o = 19\text{ MHz at }-1\text{ dBFS}$	C	-	74.5	-	dBc	
		$f_{data} = 312.5\text{ Msps}$; $f_s = 625\text{ Msps}$; 2×; BW = $f_{data} / 2$		[7]				
	$f_o = 19\text{ MHz at }-1\text{ dBFS}$	I	-	75	-	dBc		
SFDR _{RBW}	restricted bandwidth spurious-free dynamic range	$f_s = 737.28\text{ Msps}$; 4× interpolation; $f_o = 153.6\text{ MHz at }-1\text{ dBFS}$; BW = 100 MHz	I	[7]	-	81.5	-	dBc
		$f_s = 737.28\text{ Msps}$; 4× interpolation; $f_o = 153.6\text{ MHz at }-1\text{ dBFS}$; BW = 20 MHz	C	[7]	-	84	-	dBc
IMD3	third-order intermodulation distortion	$f_{o1} = 95\text{ MHz}$; $f_{o2} = 97\text{ MHz}$; $f_s = 737.28\text{ Msps}$; 4× interpolation	C	[7] [8]	-	76	-	dBc
		$f_{o1} = 153.1\text{ MHz}$; $f_{o2} = 154.1\text{ MHz}$; $f_s = 737.28\text{ Msps}$; 4× interpolation	I	[7] [8]	-	81	-	dBc
		$f_{o1} = 137\text{ MHz}$; $f_{o2} = 143\text{ MHz}$; $f_s = 737.28\text{ Msps}$; 4× interpolation	C	[7] [8]	-	80	-	dBc

Table 5. Characteristics ...continued

$V_{DDA(1V8)} = V_{DDD} = 1.7\text{ V to }1.9\text{ V}$; $V_{DDA(3V3)} = 3.13\text{ V to }3.47\text{ V}$; AGND and GND are shorted together; $T_{amb} = -40\text{ °C to }+85\text{ °C}$; typical values measured at $V_{DDA(1V8)} = V_{DDD} = 1.8\text{ V}$; $V_{DDA(3V3)} = 3.3\text{ V}$; $T_{amb} = +25\text{ °C}$; $R_L = 50\ \Omega$; $I_{O(fs)} = 20\text{ mA}$; maximum sample rate; PLL off unless otherwise specified.

Symbol	Parameter	Conditions	Test ^[1]	Min	Typ	Max	Unit	
ACPR	adjacent channel power ratio	NCO on; 4× interpolation; $f_s = 737.28\text{ Msps}$; $f_o = 96\text{ MHz}$		[7]				
		1 carrier; BW = 5 MHz	C	-	67	-	dBc	
		2 carriers; BW = 10 MHz	C	-	64	-	dBc	
		4 carriers; BW = 20 MHz	C	-	60	-	dBc	
		NCO on; 4× interpolation; $f_s = 737.28\text{ Msps}$; $f_o = 153.6\text{ MHz}$		[7]				
		1 carrier; BW = 5 MHz	C	-	67	-	dBc	
		2 carriers; BW = 10 MHz	C	-	64	-	dBc	
		4 carriers; BW = 20 MHz	C	-	59	-	dBc	
NSD	noise spectral density	$f_s = 737.28\text{ Msps}$; 4× interpolation; $f_o = 153.6\text{ MHz}$ at 0 dBFS	I	[7]	-	-145	-	dBm/Hz

- [1] D = guaranteed by design; C = guaranteed by characterization; I = 100 % industrially tested.
- [2] Delay between the deassertion of bits FORCE_RESET_FCLK and FORCE_RESET_DCLK and the deassertion of the sync signal. It reflects the delay required by DAC1008D750 to lock to a JESD204A stream. It supposes that the TX is already transmitting K28.5 characters in error-free conditions.
- [3] CLKINP/CLKINN inputs are at differential LVDS levels. An external termination resistor with a value of between 80 Ω and 120 Ω (see [Figure 15](#)) should be connected across the pins.
- [4] $|V_{gpd}|$ represents the ground potential difference voltage. This is the voltage that results from current flowing through the finite resistance and the inductance between the receiver and the driver circuit ground voltage.
- [5] Vin_p and Vin_n inputs are differential CML inputs. They are terminated internally to V_{tt} via 50 Ω (see [Figure 4](#)).
- [6] SYNC_OUTP/SYNC_OUTN outputs are differential LVDS outputs. They must be terminated by a resistor with a value of between 80 Ω and 120 Ω.
- [7] Optimum performances at high sampling rate (> 650 Msps) will be achieved with $V_{DDA(1V8)} = 1.8\text{ V} \pm 2\%$
- [8] IMD3 rejection with -6 dBFS/tone.

10. Application information

10.1 General description

The DAC1008D750 is a dual 10-bit DAC operating up to 750 Msps. With a maximum input data rate of up to 312.5 Msps and a maximum output sampling rate of 750 Msps, the DAC1008D750 allows more flexibility for wide bandwidth and multi-carrier systems. Combined with its quadrature modulator and 32-bit NCO, the DAC1008D750 simplifies the frequency selection of the system. This is also possible because of the 2×, 4× or 8× interpolation filters which remove undesired images.

DAC1008D750 supports the following JESD204A key features:

- 10-bit/8-bit decoding
- Code group synchronization
- inter-lane alignment
- $1 + x^{14} + x^{15}$ scrambling polynomial
- Character replacement
- TX/RX synchronization management via SYNC signals
- Multiple Converter Device Alignment-Multiple Lanes (MCDA-ML) device

DAC1008D750 can be interfaced with any logic device that features high-speed SERDES functionality. This macro is now widely available in FPGA from different vendors. Standalone SERDES ICs can also be used.

To enhance the intrinsic board layout simplification of the JESD204A standard, NXP includes polarity swapping for each of the lanes and additionally offers lane swapping. Each physical lane can be configured logically as lane0, lane1, lane2 or lane3.

This device is MCDA-ML compliant, offering inter-lane alignment between several devices. Samples alignment between devices is maintained up to output level because of an NXP proprietary mechanism. One device is configured as the master and all the others are configured as slaves. These will automatically align their output samples to the master ones. Therefore, a system with several DAC1008D750s can produce data with a guaranteed alignment of less than 1 DAC output clock period.

Each DAC generates two complementary current outputs on pins IOUTAP/IOUTAN and IOUTBP/IOUTBN. This provides a full-scale output current of up to 20 mA. An internal reference is available for the reference current which is externally adjustable using pin VIRES.

The DAC1008D750 must be configured before operating. Therefore, it features an SPI slave interface to access internal registers. Some of these registers also provide information about the JESD204A interface status.

The DAC1008D750 requires supplies of both 3.3 V and 1.8 V. The 1.8 V supply has separate digital and analog power supply pins. The clock input is LVDS compliant.

10.2 JESD204A receiver

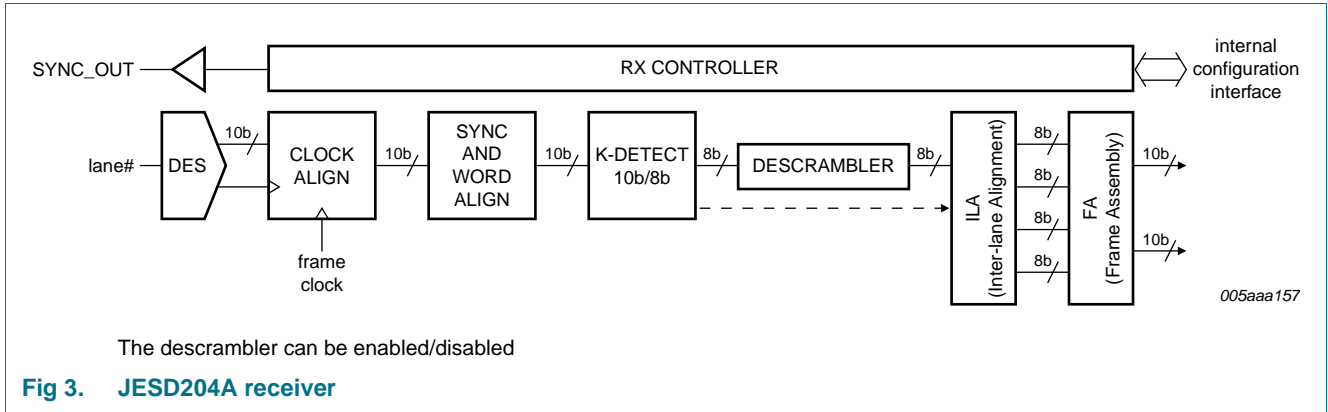

The JEDEC204A defines the following parameters:

L is the number of lanes per link

M is the number of converters per device

F is the number of bytes per frame clock period

The DAC1008D750 supports both LMF = 421 and LMF = 211. The current setting is configurable via the SPI registers interface.

The complete Digital Layer Processing (DLP) adds a variable delay on each lane path. This is mainly because of the inter-lane alignment.

Table 6. Digital Layer Processing Latency

Symbol	Parameter	Conditions	Test ^[1]	Min	Typ	Max	Unit
t _d	delay time	digital layer processing delay	D	13	-	28	cycle ^[2]

[1] D = guaranteed by design.

[2] Frame clock cycle.

10.2.1 Lane input

Each lane is CML compliant. It is terminated to a common voltage with an integrated 50 Ω resistor.

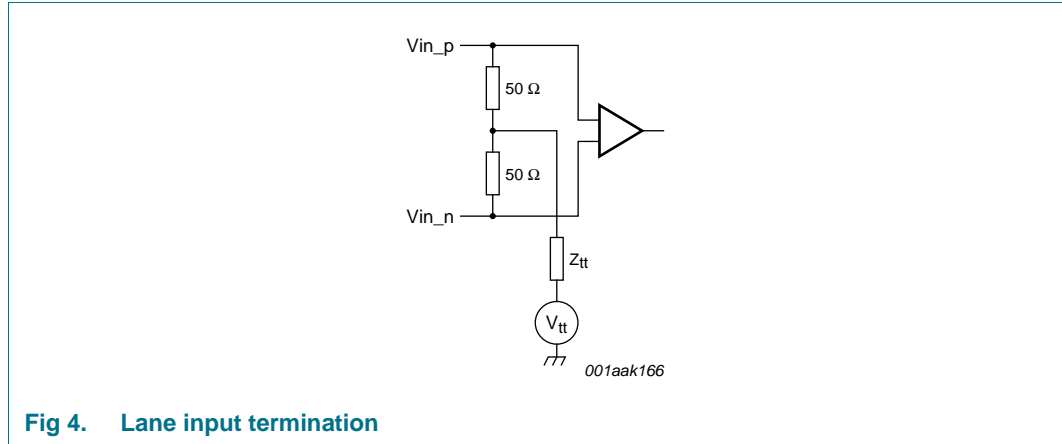

Fig 4. Lane input termination

The common-mode voltage is programmable by the SET_VCM_VOLTAGE register as shown in [Table 75 on page 56](#).

DC coupling is only possible if both the DAC and the transmitter have the same common-mode voltage. If this is not the case, AC coupling is required.

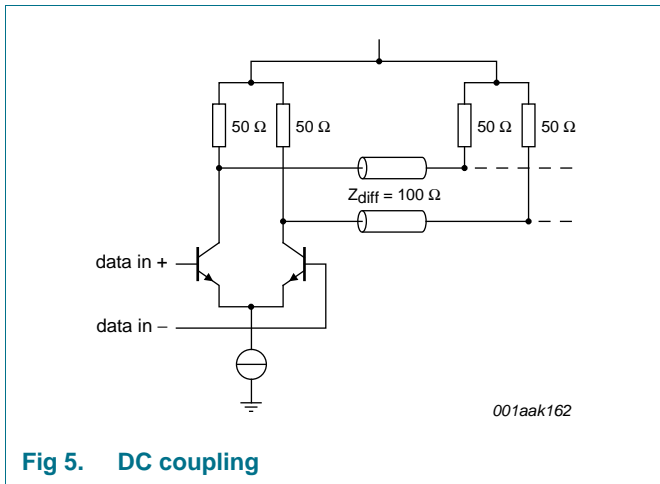

Fig 5. DC coupling

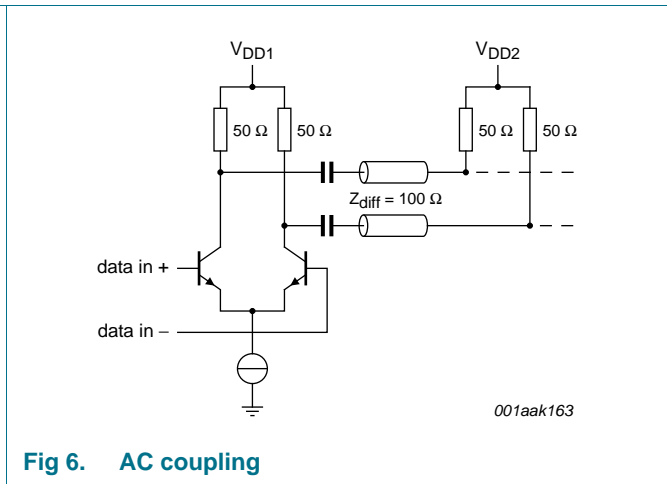

Fig 6. AC coupling

The deserializer performs the incoming data clock recovery and also the serial-to-parallel conversion. Therefore, each lane includes its own PLL that must first lock.

The clock alignment module transfers the data from the regenerated clock to the frame clock domain. The frequency of both clocks is the same but the phase relationship between the clocks is unknown.

10.2.2 Sync and word align

As stated in JESD204A, the transmitter and the receiver first have to synchronize. This is achieved through the SYNC_OUT signals and a sync pattern (K28.5 symbol). The receiver (i.e. DAC1008D750) first drives its SYNC_OUT outputs. The sync pattern is continuously sent until the receiver deasserts the SYNC_OUT signal.

The lane processing makes use of the sync patterns to synchronize the datastream, determine the initial running disparity and extract the 10-bit word from the incoming datastream (word-alignment).

The SYNC_OUT signal is also used during normal operation by the DAC1008D750 to request a link reinitialization. This occurs when the 10b/8b module loses synchronization.

The SYNC_OUT signal conforms to LVDS signaling. Its common-mode voltage and its single-ended peak amplitude can be programmed using SET_SYNC_LEVEL bits in the SET_SYNC registers (see [Table 77 on page 56](#)).

SYNC_OUT is asynchronous with the frame clock. There is no timing specification with respect to the CLKINP and CLKINN inputs.

10.2.3 Comma detection and word align

This stage monitors the datastream for code characters (Comma detection), decodes the words to bytes (octets) and performs optional character replacement as part of frame/lane alignment monitoring and correction. This module provides the required control signals to the RX-controller and ILA.

This module decodes the 10-bit words into 8-bit words (octets). The decoding table is specified in the IEEE 802.3-2005 specification. During decoding, the disparity is calculated according to the disparity rules mentioned in the same specification IEEE 802.3-2005. When the disparity counter is more than +2 or less than -2, an error will be generated.

The following comma symbols are detected during data transmission irrespective of the running disparity:

/K/ = K28.5

/F/ = K28.7

/A/ = K28.3

/R/ = K28.0

/Q/ = K28.4

A flag is sent to the control interface to reflect detected commas in registers.

The following flags are also triggered according to the following definitions:

- VALID: a code group that is found in the column of the 10b/8b decoding tables according to the current running disparity.
- DISPARITY ERROR: The received code group exists in the 10b/8b decoding table, but is not found in the proper column according to the current running disparity.
- NOT-IN-TABLE (NIT) ERROR: The received code group is not found in the 10b/8b decoding table for either disparity.
- INVALID: a code group that either shows a disparity error or that does not exist in the 10b/8b decoding table.

DAC1008D750 supports character replacement whatever the state of the descrambler. When scrambling is not active, the received K28.3 /A/ or K28.7 /F/ will be replaced by the previous sample. When scrambling is active, the corresponding data octet D28.3 (0xC) or D28.7 (0xFC) will be used.

10.2.4 Descrambler

The descrambler is a 16-bit parallel self-synchronous descrambler based on the polynomial $1 + x^{14} + x^{15}$. This processing can be turned off.

10.2.5 Inter-lane alignment

This feature removes strict PCB design skew compensation between the lanes.

10.2.5.1 Single device operation

This module handles the alignment of the four data streams. Because of inter-lane skew and each PLL per lane concept, these alignment characters may be received at different times by the receivers. After the synchronization period, the lock signal will be HIGH. This enables the receipt of K28.3 /A/ characters.

The ILA_CNTRL register's SEL_ILA[1:0] bits select which K28.3 /A/ symbol triggers the initial lane alignment: "00" = 1st /A/ symbol, "01" = 2nd /A/ symbol, "10" = 3rd /A/ symbol, "11" = 4th /A/ symbol; [Table 86 on page 62](#). When all receivers have received their first selected /A/, they start propagating the received data to the frame assembly module at the same point in time.

This module can compensate for up to ± 7 frame clock period misalignments between the lanes.

When initial lane alignment is not supported, the manual alignment mode can be used.

After the initial ILA sequence, the lane alignment monitoring starts. If the received user data contains K28.3 /A/ symbol:

- its position is compared to the value of the alignment monitor counter
- if two successive K28.3 /A/ symbols have been received at a wrong position, a realignment takes place
- if the buffers are empty or overflow, this is indicated by the registers ILA_BUF_ERR_LN0 to ILA_BUF_ERR_LN3

10.2.5.2 Multi-device operation

DAC1008D750 implements a multi-device inter-lane alignment that guarantees a skew of less than one output period between them.

Two modes are available: master/slave and all slave. Both make use of the MDS_P and MDS_N pins.

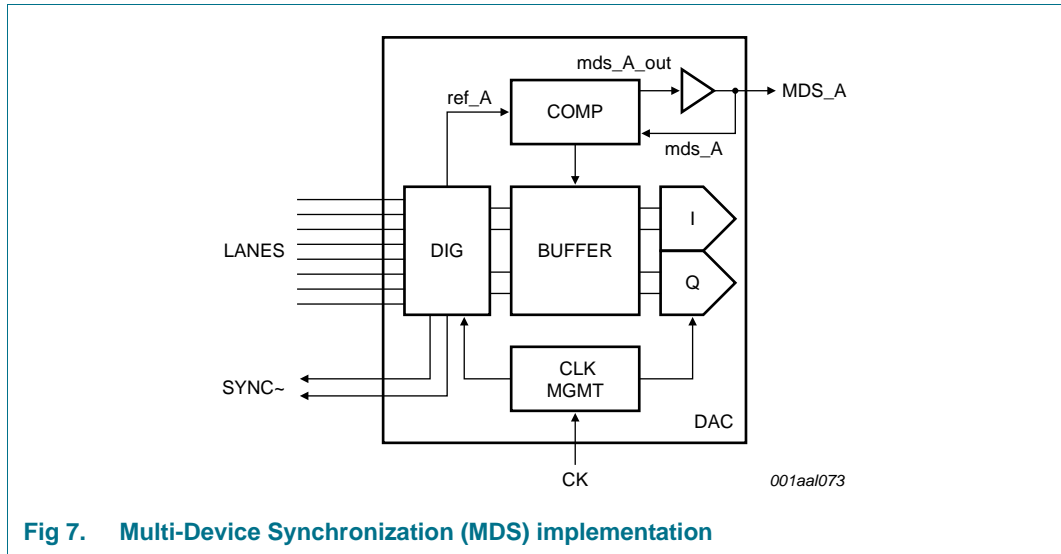

Fig 7. Multi-Device Synchronization (MDS) implementation

Each DAC device of the system generates its own reference (ref_A in [Figure 7](#)).

If configured as a slave, an early-late comparator compares the internal reference with the external reference provided by the MDS pins. The comparator controls an internal buffer that is used to delay the samples.

10.2.5.3 Master/slave mode

The external reference is provided by one of the DACs (the master DAC), which has to be configured to do this. The others are set to slave mode.

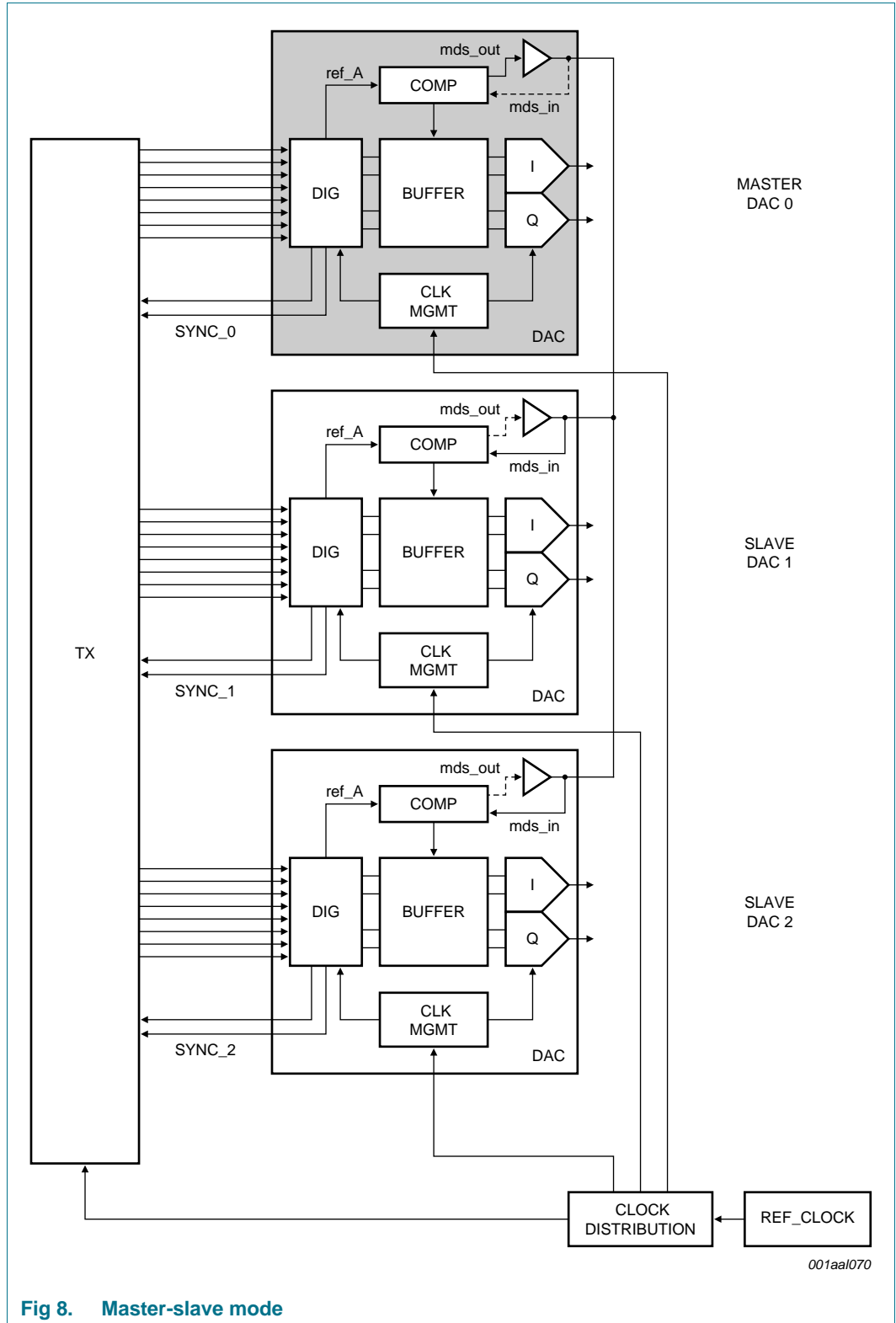

Fig 8. Master-slave mode

001aa1070

The MDS signal generated by the master DAC must reach all slaves within one DAC output clock period. This induces PCB layout constraints for the MDS signal and also for the clock distribution. Because trace lengths differ, the clock edges will reach each of the DACs at different times.

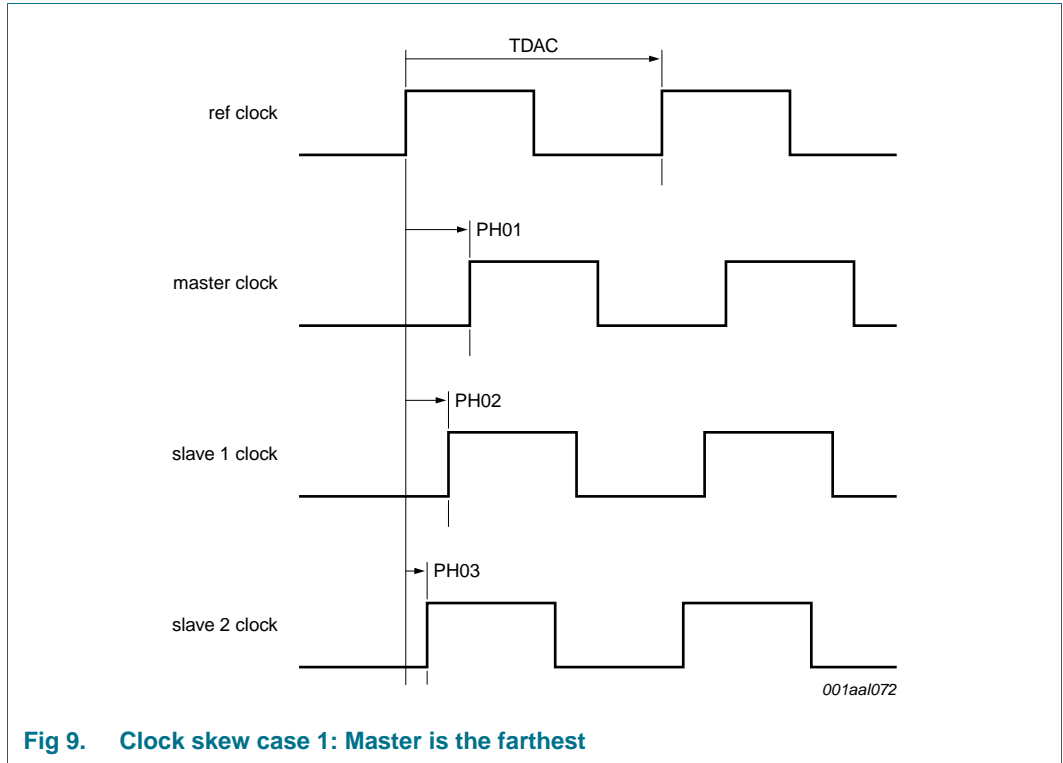

Fig 9. Clock skew case 1: Master is the farthest

The worst case clock skew is given by $\delta t_1 = PH01 - PH03$, where $PH0x$ represents the sum of the trace delay and the clock skew at the output of the clock generator.

The maximum allowable trace delay for the MDS signal is given by $\Delta t = TDAC - \delta t_1$.

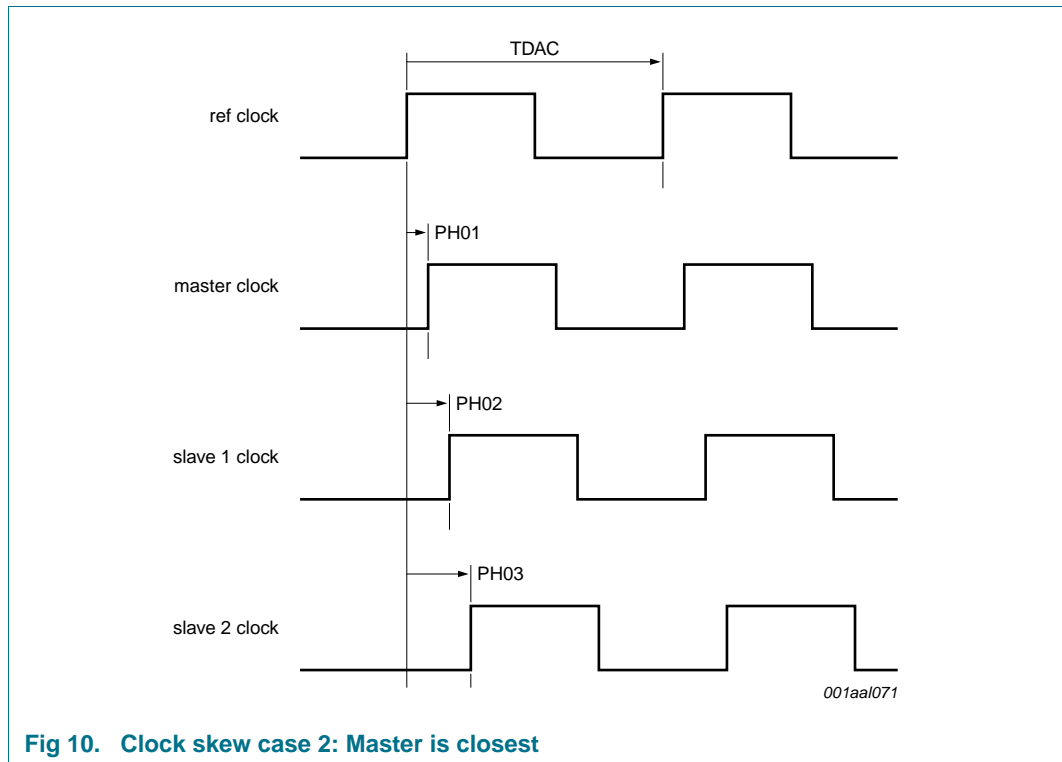

Fig 10. Clock skew case 2: Master is closest

The worst case clock skew is given by $\delta t_2 = PH03 - PH01$.

The minimum allowable trace delay for the MDS signal is given by $\Delta t = \delta t_2$.

In real applications, the master DAC can be anywhere and both conditions must be satisfied: $\delta t_2 < \Delta t_{m\text{ds}} < TDAC - \delta t_1$.

Example:

- clock generator skew = ± 80 ps
- FR4 substrate $\Rightarrow 15$ cm/ns delay
- clock trace length difference = 3 cm and 4 cm
- Output sampling rate = 750 Msps

$$\Rightarrow 200 \text{ ps} + 80 \text{ ps} < \Delta t_{m\text{ds}} < 1333 \text{ ps} - (266 \text{ ps} + 80 \text{ ps})$$

$$\Rightarrow 280 \text{ ps} < \Delta t_{m\text{ds}} < 987 \text{ ps}$$

$$\Rightarrow 4.2 \text{ cm} < L_{m\text{ds}} < 14.8 \text{ cm}$$

10.2.5.4 All slave mode

The external reference is provided by the JESD204A transmitter. All DACs are configured in slave mode.

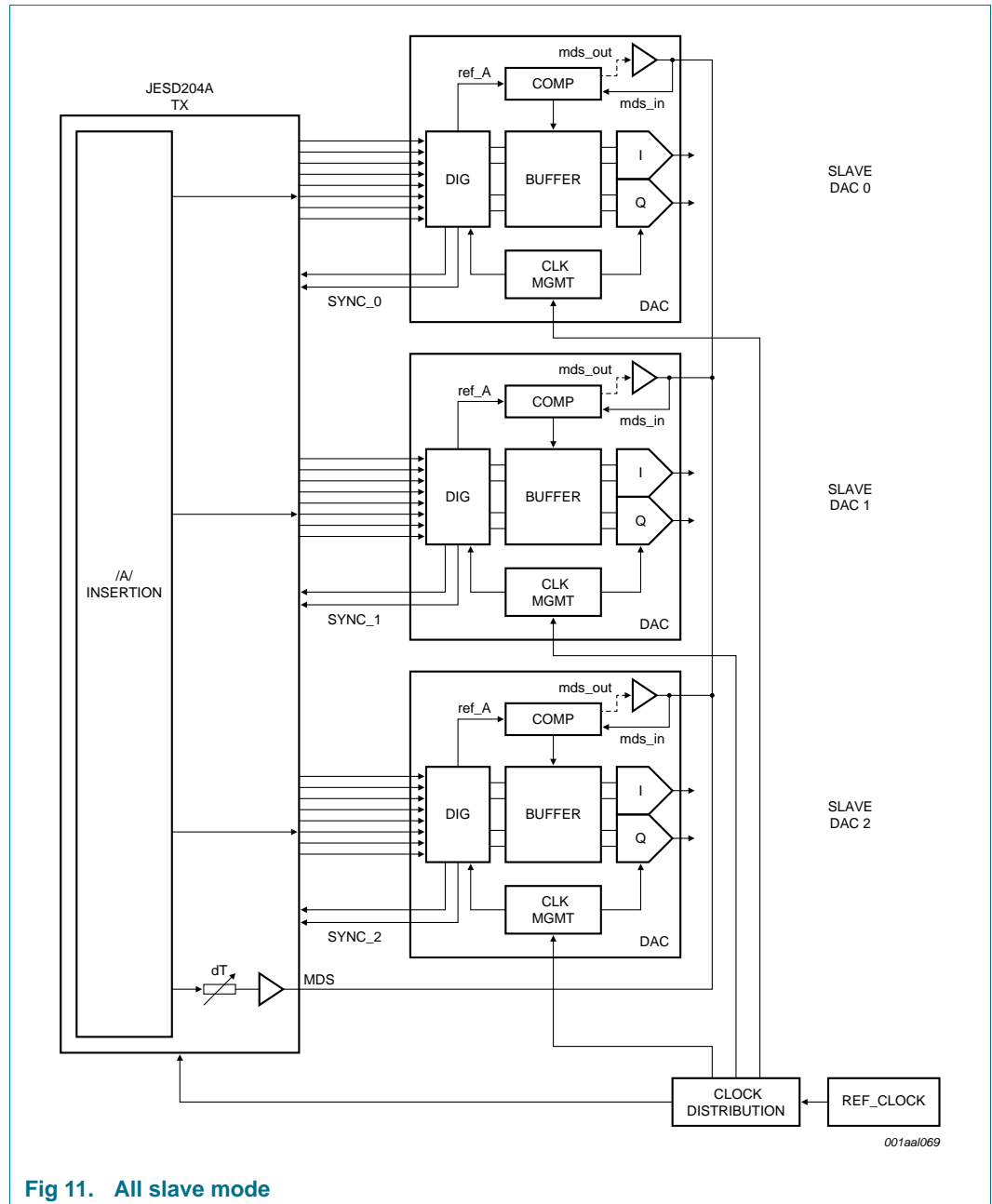

Fig 11. All slave mode

The MDS signal is now driven from the transmitter. It is generated at the end of the inter-lane alignment phase (see the JESD204A standard for details).

The transmitter must also compensate for the DAC latency. Although the DAC has an internal samples delay line, it cannot handle large delays.

In this mode, PCB layout is also important. The following delay equation applies: $\delta t < \Delta t_{m_{ds}} < TDAC - \delta t$, where δt is the clock skew considered close to DAC pins.

10.2.6 Frame assembly

DAC1008D750 supports only $/F/ = 1$, which means that every frame clock period carries one byte per lane. Frame assembly combines the octet of lane_0 with the two MSB bits of lane_1 and reassembles the original 10-bit sample. The same is done for lane_2 and lane_3. Tail bits are dropped.

The frame assembler also handles previously triggered errors.

If scrambling is enabled:

If a nit_err (not-in-table error) or kout_unexp (unexpected control character) occurs in lane_0 and/or lane_1, the previous 10-bit sample is repeated twice for I (lane_0, lane_1). The same is done for Q (lane_2, lane_3).

If scrambling is disabled:

If a nit_err (not-in-table error) or kout_unexp (unexpected control character) occurs in lane_0 and/or lane_1, the previous 10-bit sample will be repeated once for I (lane_0, lane_1). The same is done for Q (lane_2, lane_3).

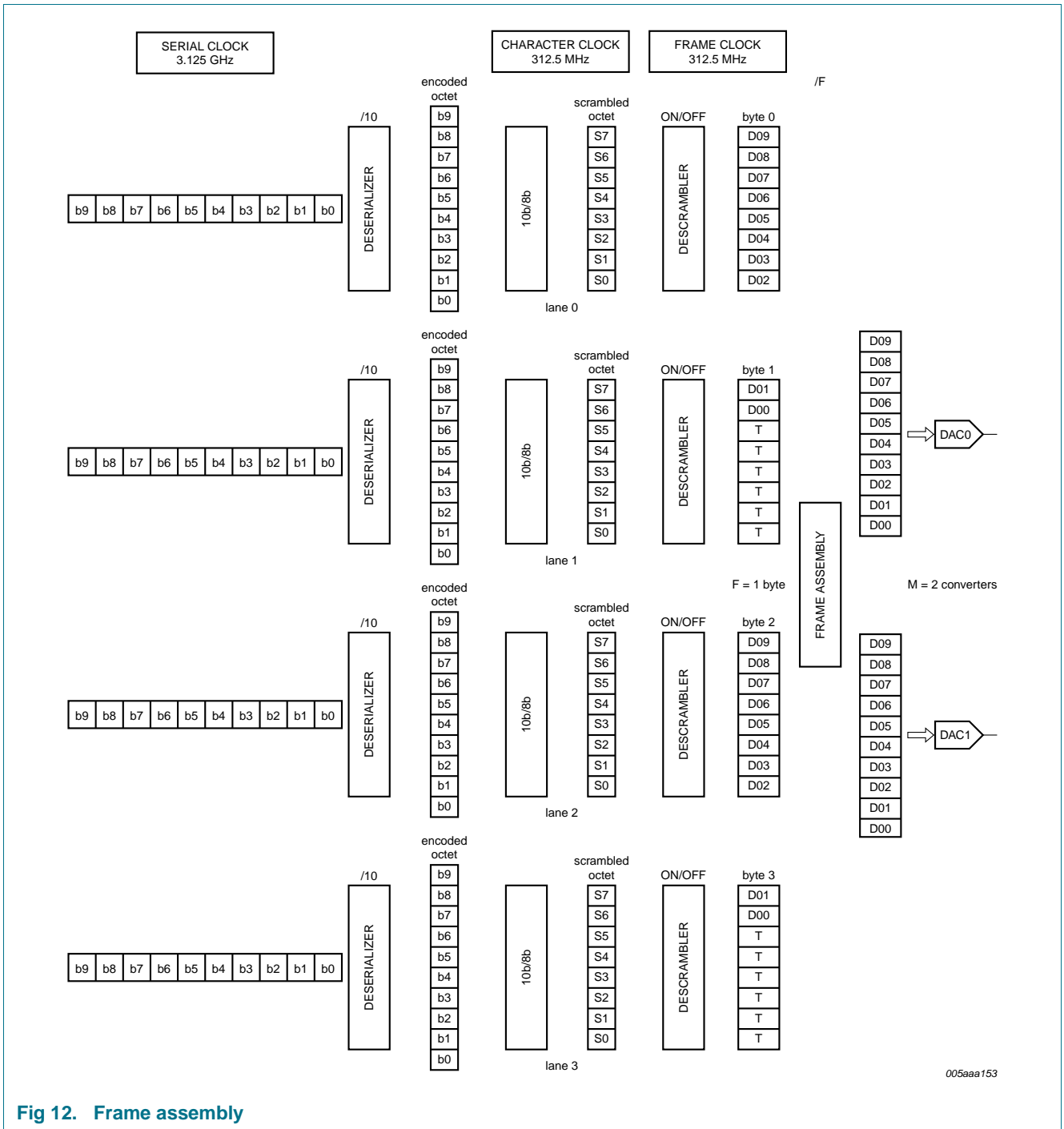

Fig 12. Frame assembly

10.3 Serial Peripheral Interface (SPI)

10.3.1 Protocol description

The DAC1008D750 serial interface is a synchronous serial communication port allowing easy interfacing with many industry microprocessors. It provides access to the registers that define the operating modes of the chip in both Write mode and Read mode.

This interface can be configured as a 3-wire type (SDIO as bidirectional pin) or a 4-wire type (SDIO and SDO as unidirectional pin, input and output port respectively). In both configurations, SCLK acts as the serial clock and SCS_N acts as the serial chip select bar.

Each read/write operation is sequenced by the SCS_N signal and enabled by a LOW assertion to drive the chip with two bytes to five bytes, depending on the content of the instruction byte (see [Table 8](#)).

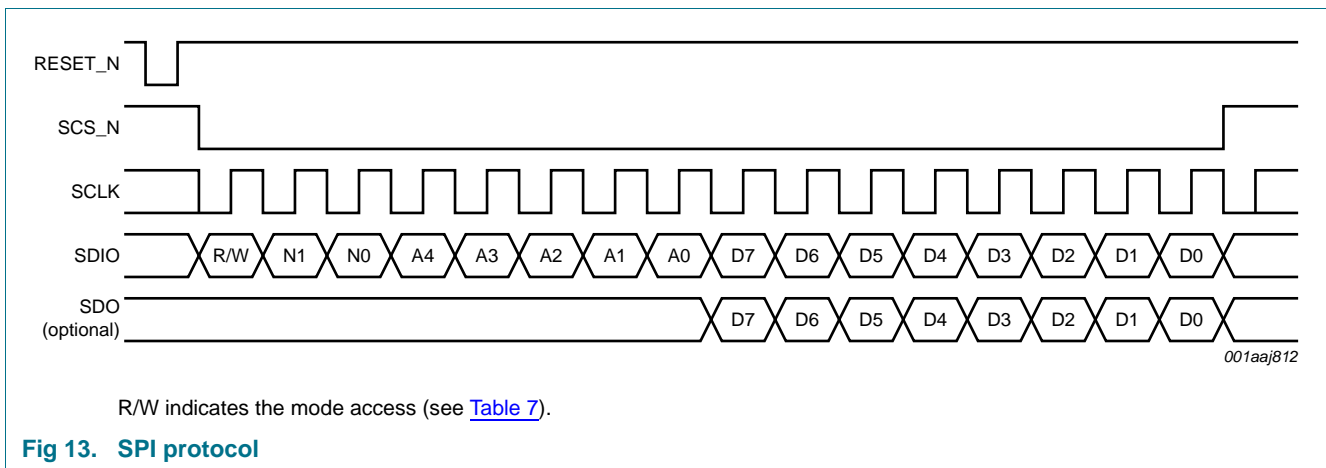

Fig 13. SPI protocol

Table 7. Read or Write mode access description

R/W	Description
0	Write mode operation
1	Read mode operation

In [Table 8](#) below, N1 and N0 indicate the number of bytes transferred after the instruction byte.

Table 8. Number of bytes to be transferred

N1	N0	Number of bytes transferred
0	0	1
0	1	2
1	0	3
1	1	4

A[4:0] indicates which register is being addressed. In the case of a multiple transfer, this address points to the first register to be accessed. The address is then internally decreased after each following data phase.

10.3.2 SPI timing description

The SPI interface can operate at a frequency of up to 15 MHz. The SPI timing is shown in [Figure 14](#).

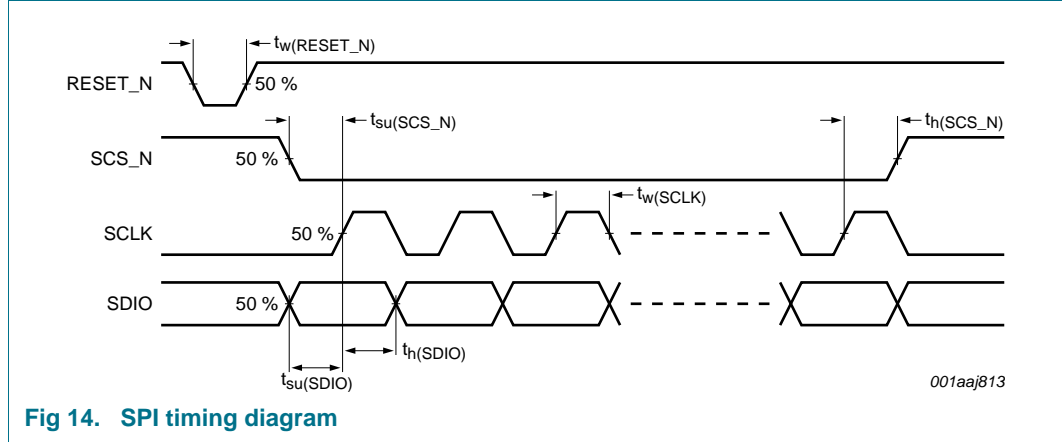

Fig 14. SPI timing diagram

The SPI timing characteristics are given in [Table 9](#).

Table 9. SPI timing characteristics

Symbol	Parameter	Min	Typ	Max	Unit
f_{SCLK}	SCLK frequency	-	-	15	MHz
$t_w(\text{SCLK})$	SCLK pulse width	30	-	-	ns
$t_{su}(\text{SCS_N})$	SCS_N set-up time	20	-	-	ns
$t_h(\text{SCS_N})$	SCS_N hold time	20	-	-	ns
$t_{su}(\text{SDIO})$	SDIO set-up time	10	-	-	ns
$t_h(\text{SDIO})$	SDIO hold time	5	-	-	ns
$t_w(\text{RESET_N})$	RESET_N pulse width	30	-	-	ns

10.4 Clock input

The DAC1008D750 has one differential clock input, CLKINN/CLKINP.

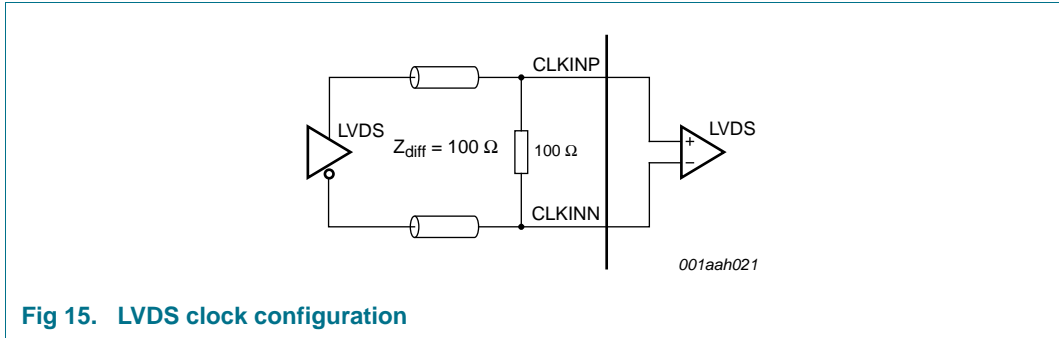

Fig 15. LVDS clock configuration

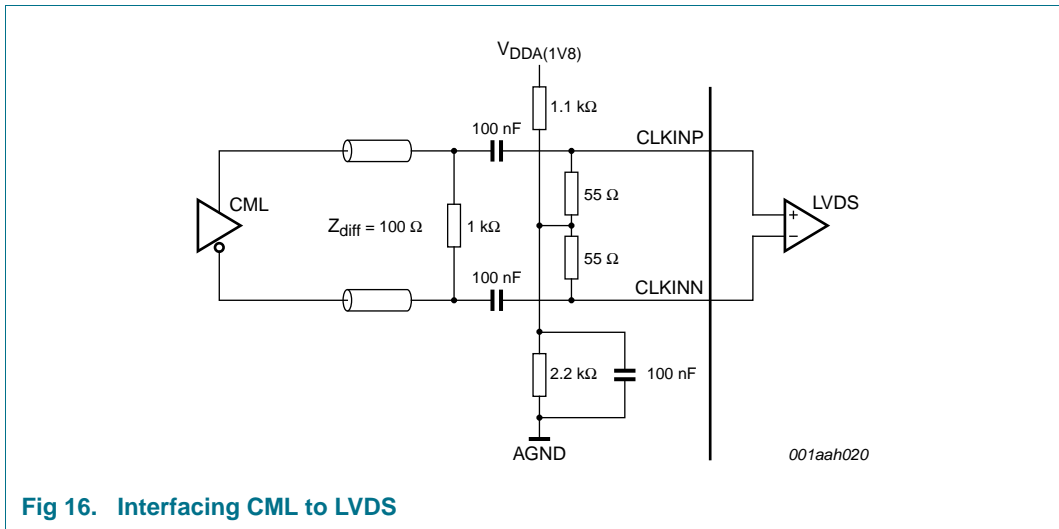

Fig 16. Interfacing CML to LVDS

The DAC1008D750 can operate with a clock frequency up to 312.5 MHz or up to 750 MHz if the internal PLL is bypassed. The clock input can be LVDS (see Figure 15) but it can also be interfaced with CML (see Figure 16). Error free data transition from one internal clock domain to another one is handled by Clock Domain Interface (CDI) logic.

During the reset phase (RESET_N asserted), the clock must be stable and running. This ensures a proper reset of the complete device.

The device has no embedded power-on-reset feature. Driving the RESET_N pin to set the device to its default state is mandatory.

10.5 FIR filters

The three interpolation FIR filters have a stop band attenuation of at least 80 dBc and a pass band ripple of less than 0.0005 dB.

Table 10. Interpolation filter coefficients

First interpolation filter			Second interpolation filter			Third interpolation filter		
Lower	Upper	Value	Lower	Upper	Value	Lower	Upper	Value
H(1)	H(55)	-4	H(1)	H(23)	-2	H(1)	H(15)	-39
H(2)	H(54)	0	H(2)	H(22)	0	H(2)	H(14)	0
H(3)	H(53)	13	H(3)	H(21)	17	H(3)	H(13)	273
H(4)	H(52)	0	H(4)	H(20)	0	H(4)	H(12)	0
H(5)	H(51)	-34	H(5)	H(19)	-75	H(5)	H(11)	-1102
H(6)	H(50)	0	H(6)	H(18)	0	H(6)	H(10)	0
H(7)	H(49)	72	H(7)	H(17)	238	H(7)	H(9)	4964
H(8)	H(48)	0	H(8)	H(16)	0	H(8)	-	8192
H(9)	H(47)	-138	H(9)	H(15)	-660	-	-	-
H(10)	H(46)	0	H(10)	H(14)	0	-	-	-
H(11)	H(45)	245	H(11)	H(13)	2530	-	-	-
H(12)	H(44)	0	H(12)	-	4096	-	-	-
H(13)	H(43)	-408	-	-	-	-	-	-
H(14)	H(42)	0	-	-	-	-	-	-
H(15)	H(41)	650	-	-	-	-	-	-
H(16)	H(40)	0	-	-	-	-	-	-
H(17)	H(39)	-1003	-	-	-	-	-	-
H(18)	H(38)	0	-	-	-	-	-	-
H(19)	H(37)	1521	-	-	-	-	-	-
H(20)	H(36)	0	-	-	-	-	-	-
H(21)	H(35)	-2315	-	-	-	-	-	-
H(22)	H(34)	0	-	-	-	-	-	-
H(23)	H(33)	3671	-	-	-	-	-	-
H(24)	H(32)	0	-	-	-	-	-	-
H(25)	H(31)	-6642	-	-	-	-	-	-
H(26)	H(30)	0	-	-	-	-	-	-
H(27)	H(29)	20756	-	-	-	-	-	-
H(28)	-	32768	-	-	-	-	-	-

10.6 Quadrature modulator and Numerically Controlled Oscillator (NCO)

The quadrature modulator allows the 10-bit I and Q data to be mixed with the carrier signal generated by the NCO.

The frequency of the NCO is programmed over 32 bits and the sign of the sine component can be inverted in order to operate positive or negative, lower or upper single sideband up-conversion.

10.6.1 NCO in 32-bit

When using the NCO, the frequency can be set by the four registers `FREQNCO_LSB`, `FREQNCO_LISB`, `FREQNCO_UISB` and `FREQNCO_MSB` over 32 bits.

The frequency for the NCO in 32-bit is calculated as follows:

$$f_{NCO} = \frac{M \times f_s}{2^{32}} \quad (1)$$

where M is the decimal representation of `FREQ_NCO[31:0]`.

The phase of the NCO can be set from 0° to 360° by both registers `PHINCO_LSB` and `PHINCO_MSB` over 16 bits.

The default setting is $f_{NCO} = 96$ MHz when $f_s = 640$ Msp/s and the default phase is 0°.

10.6.2 Low-power NCO

When using the low-power NCO, the frequency can be set by the five MSBs of register `FREQNCO_MSB`.

The frequency for the low-power NCO is calculated as follows:

$$f_{NCO} = \frac{M \times f_s}{2^5} \quad (2)$$

where M is the decimal representation of `FREQ_NCO[31:27]`.

The phase of the low-power NCO can be set by the five MSBs of the register `PHINCO_MSB`.

10.6.3 Minus_3dB

During normal use, a full-scale pattern will also be full-scale at the output of the DAC. Nevertheless, when the I and Q data are simultaneously close to full-scale, some clipping can occur and the `minus_3dB` function can be used to reduce the gain in the modulator by 3 dB. This is to keep a full-scale range at the output of the DAC without added interferers.

10.7 x / (sin x)

The roll-off effect of the DAC causes a selectable FIR filter to be inserted to compensate for the $(\sin x) / x$ effect. This filter introduces a DC loss of 3.4 dB. The coefficients are represented in [Table 11](#).

Table 11. Inversion filter coefficients

First interpolation filter		
Lower	Upper	Value
H(1)	H(9)	2
H(2)	H(8)	-4
H(3)	H(7)	10
H(4)	H(6)	-35
H(5)	-	401

10.8 DAC transfer function

The full-scale output current for each DAC is the sum of the two complementary current outputs:

$$I_{O(fs)} = I_{IOUTP} + I_{IOUTN} \tag{3}$$

The output current depends on the digital input data:

$$I_{IOUTP} = I_{O(fs)} \times \left(\frac{DATA}{1023} \right) \tag{4}$$

$$I_{IOUTN} = I_{O(fs)} \times \left(\frac{1023 - DATA}{1023} \right) \tag{5}$$

The setting applied to register COMMON bit DF (register 00h[2]; see [Table 17 “Page 0 register allocation map”](#)) defines whether the DAC1008D750 operates with a binary input or a two’s complement input.

[Table 12](#) shows the output current as a function of the input data, when $I_{O(fs)} = 20 \text{ mA}$.

Table 12. DAC transfer function

Data	I9/Q9 to I0/Q0		IOUTnP	IOUTnN
	Binary	Two’s complement		
0	00 0000 0000	10 0000 0000	0 mA	20 mA
...
2048	10 0000 0000	00 0000 0000	10 mA	10 mA
...
4095	11 1111 1111	01 1111 1111	20 mA	0 mA

10.9 Full-scale current

10.9.1 Regulation

The DAC1008D750 reference circuitry integrates an internal bandgap reference voltage which delivers a 1.29 V reference to the GAPOUT pin. It is recommended to decouple pin GAPOUT using a 100 nF capacitor.

The reference current is generated via an external resistor of 953 Ω (1 %) connected to pin VIRES. A control amplifier sets the appropriate full-scale current ($I_{O(fs)}$) for both DACs (see [Figure 17](#)).

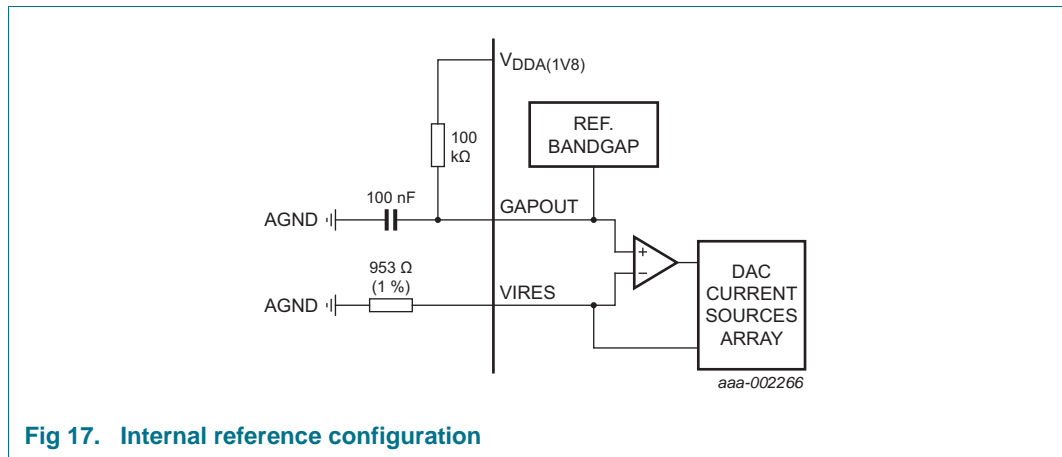

Fig 17. Internal reference configuration

This configuration is optimum for temperature drift compensation because the bandgap reference voltage can be matched to the voltage across the feedback resistor.

10.9.1.1 External regulation

The DAC current can also be set by applying an external reference voltage to the non-inverting input pin GAPOUT and disabling the internal bandgap reference voltage with bit GAP_PD (register 00h[0]; see [Table 18 “COMMON register \(address 00h\) bit description”](#)).

10.9.2 Full-scale current adjustment

The default full-scale current ($I_{O(fs)}$) is 20 mA but further adjustments can be made by the user to both DACs independently using the serial interface from 1.6 mA to 22 mA, ± 10 %.

The settings applied to DAC_A_GAIN_COARSE[3:0] (register 0Ah; see [Table 28 “DAC_A_CFG_2 register \(address 0Ah\) bit description”](#) and register 0Bh; see [Table 29 “DAC_A_CFG_3 register \(address 0Bh\) bit description”](#)) and DAC_B_GAIN_COARSE[3:0] (register 0Dh; see [Table 31 “DAC_B_CFG_2 register \(address 0Dh\) bit description”](#) and register 0Eh; see [Table 32 “DAC_B_CFG_3 register \(address 0Eh\) bit description”](#)) define the coarse variation of the full-scale current (see [Table 13](#)).

Table 13. $I_{O(fs)}$ coarse adjustment

Default settings are shown highlighted.

DAC_GAIN_COARSE[3:0]		$I_{O(fs)}$ (mA)
Decimal	Binary	
0	0000	1.6
1	0001	3.0
2	0010	4.4
3	0011	5.8
4	0100	7.2
5	0101	8.6
6	0110	10.0
7	0111	11.4
8	1000	12.8
9	1001	14.2
10	1010	15.6
11	1011	17.0
12	1100	18.5
13	1101	20.0
14	1110	21.0
15	1111	22.0

The settings applied to DAC_A_GAIN_FINE[5:0] (register 0Ah; see [Table 28](#) “DAC_A_CFG_2 register (address 0Ah) bit description”) and to DAC_B_GAIN_FINE[5:0] (register 0Dh; see [Table 31](#) “DAC_B_CFG_2 register (address 0Dh) bit description”) define the fine variation of the full-scale current (see [Table 14](#)).

Table 14. $I_{O(fs)}$ fine adjustment

Default settings are shown highlighted.

DAC_GAIN_FINE[5:0]		Delta $I_{O(fs)}$
Decimal	Two's complement	
-32	10 0000	-10 %
...
0	00 0000	0
...
31	01 1111	+10 %

The coding of the fine gain adjustment is two's complement.

10.10 Digital offset correction

When the DAC1008D750 analog output is DC connected to the next stage, the digital offset correction can be used to adjust the common-mode level at the output of the DAC. It adds an offset at the end of the digital part, just before the DAC.

The settings applied to DAC_A_OFFSET[11:0] (register 09h; see [Table 27](#) “DAC_A_CFG_1 register (address 09h) bit description”) and register 0Bh; see [Table 29](#) “DAC_A_CFG_3 register (address 0Bh) bit description”) and to “DAC_B_OFFSET[11:0]”

(register 0Ch; see [Table 30 “DAC_B_CFG_1 register \(address 0Ch\) bit description”](#) and register 0Eh; see [Table 32 “DAC_B_CFG_3 register \(address 0Eh\) bit description”](#)) define the range of variation of the digital offset (see [Table 15](#)).

Table 15. Digital offset adjustment
Default settings are shown highlighted.

DAC_OFFSET[11:0]		Offset applied
Decimal	Two's complement	
-2048	1000 0000 0000	-4096
-2047	1000 0000 0001	-4094
...
-1	1111 1111 1111	-2
0	0000 0000 0000	0
+1	0000 0000 0001	+2
...
2046	0111 1111 1110	+4092
2047	0111 1111 1111	+4094

10.11 Analog output

The DAC1008D750 has two output channels each of which produces two complementary current outputs. These allow the even-order harmonics and noise to be reduced. The pins are IOUTAP/IOUTAN and IOUTBP/IOUTBN respectively and need to be connected via a load resistor R_L to the 3.3 V analog power supply ($V_{DDA(3V3)}$).

The equivalent analog output circuit of one DAC is shown in [Figure 18](#). This circuit consists of a parallel combination of NMOS current sources, and their associated switches, for each segment.

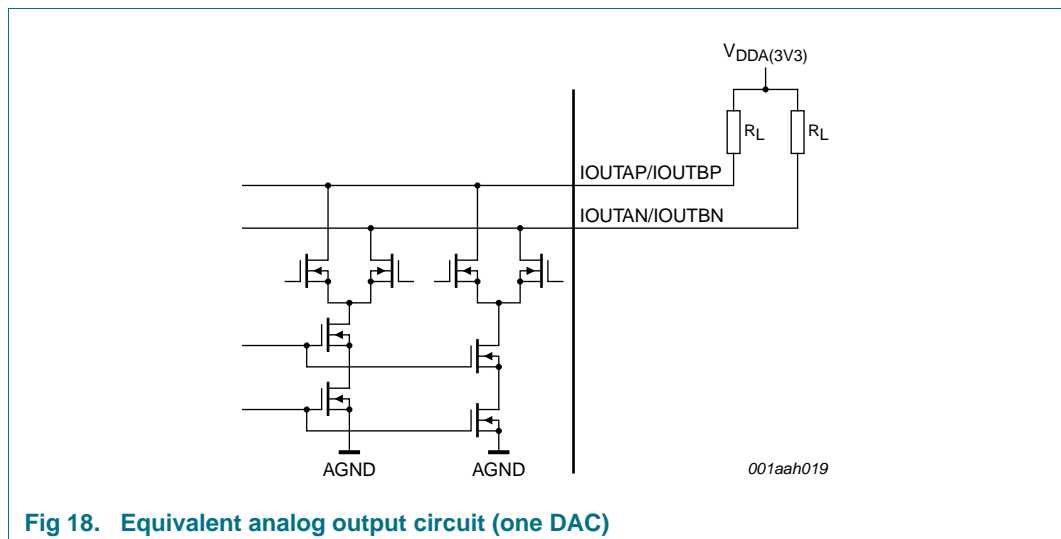

Fig 18. Equivalent analog output circuit (one DAC)

The cascode source configuration increases the output impedance of the source, thus improving the dynamic performance of the DAC by introducing less distortion.

The device can provide an output level ($V_{o(p-p)}$) of up to 2 V, depending on the application, the following stages and the targeted performances.

10.12 Auxiliary DACs

The DAC1008D750 integrates two auxiliary DACs that can be used to compensate for any offset between the DAC and the next stage in the transmission path.

Both auxiliary DACs have a 10-bit resolution and are current sources (referenced to ground).

$$I_{O(AUX)} = I_{AUXP} + I_{AUXN} \tag{6}$$

The output current depends on the auxiliary DAC data:

$$AUXP = I_{O(AUX)} \times \left(\frac{AUX[9:0]}{1023} \right) \tag{7}$$

$$AUXN = I_{O(AUX)} \times \left(\frac{(1023 - AUX[9:0])}{1023} \right) \tag{8}$$

[Table 16](#) shows the output current as a function of the auxiliary DAC data.

Table 16. Auxiliary DAC transfer function

Default settings are shown highlighted.

Data	AUX[9:0] (binary)	I _{AUXP}	I _{AUXN}
0	00 0000 0000	0 mA	2.2 mA
...
512	10 0000 0000	1.1 mA	1.1 mA
...
1023	11 1111 1111	2.2 mA	0 mA

10.13 Output configuration

10.13.1 Basic output configuration

The use of a differentially-coupled transformer output provides optimum distortion performance (see [Figure 19](#)). In addition, it helps to match the impedance and provides electrical isolation.

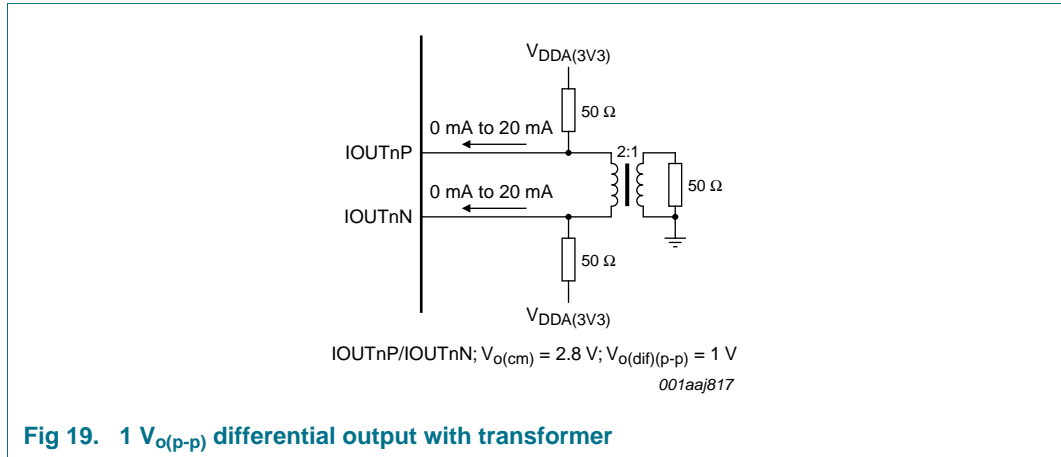

Fig 19. 1 V_{o(p-p)} differential output with transformer

The DAC1008D750 can operate at a V_{o(p-p)} of 2 V differential outputs. In this configuration, it is recommended to connect the center tap of the transformer to a 62 Ω resistor connected to the 3.3 V analog power supply, in order to adjust the DC common-mode to approximately 2.7 V (see [Figure 20](#)).

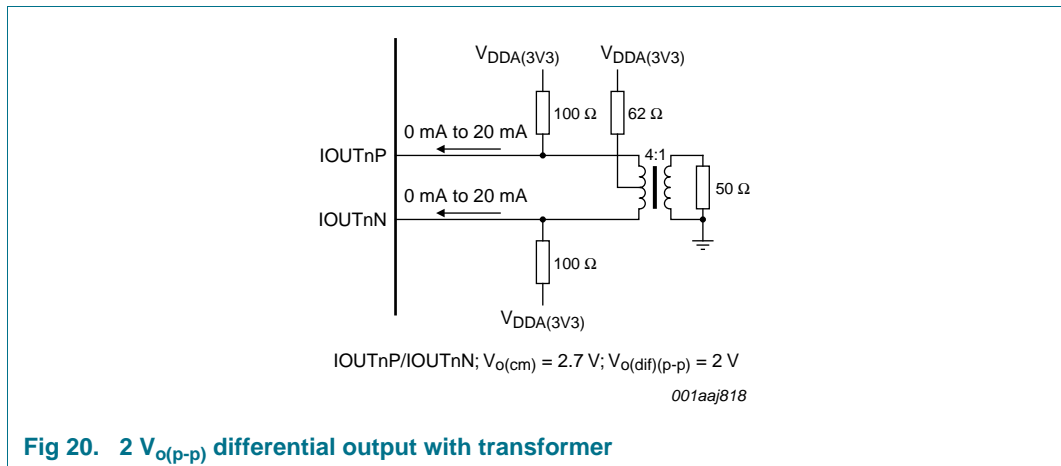

Fig 20. 2 V_{o(p-p)} differential output with transformer

10.13.2 DC interface to an Analog Quadrature Modulator (AQM)

When the system operation requires to keep the DC component of the spectrum, the DAC1008D750 must use a DC interface to connect to an AQM. In this case, the offset compensation for LO cancellation can be made with the use of the digital offset control in the DAC.

Figure 21 is an example of a connection to an AQM with a common-mode input level ($V_{i(cm)}$) of 1.7 V.

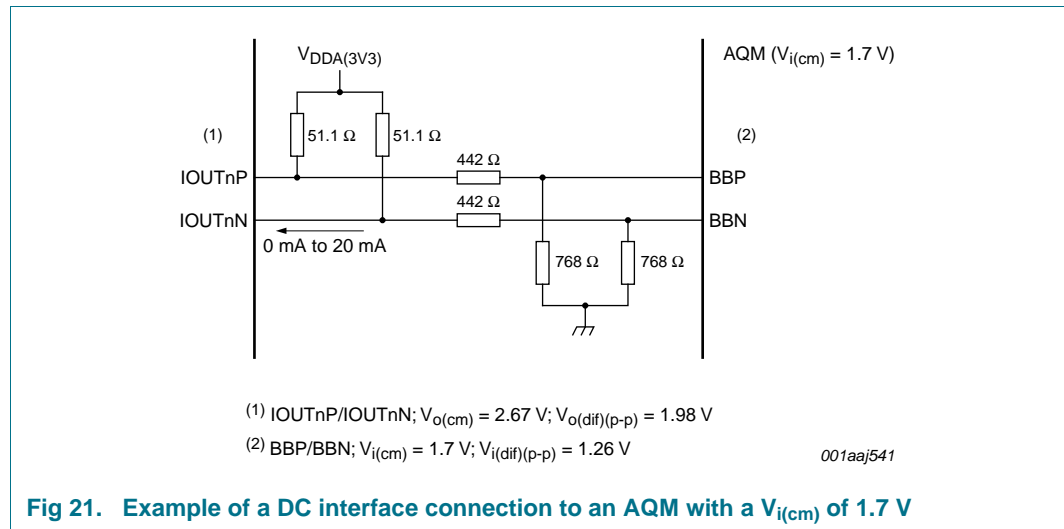

Fig 21. Example of a DC interface connection to an AQM with a $V_{i(cm)}$ of 1.7 V

Figure 22 is an example of a connection to an AQM with a common-mode input level ($V_{i(cm)}$) of 3.3 V.

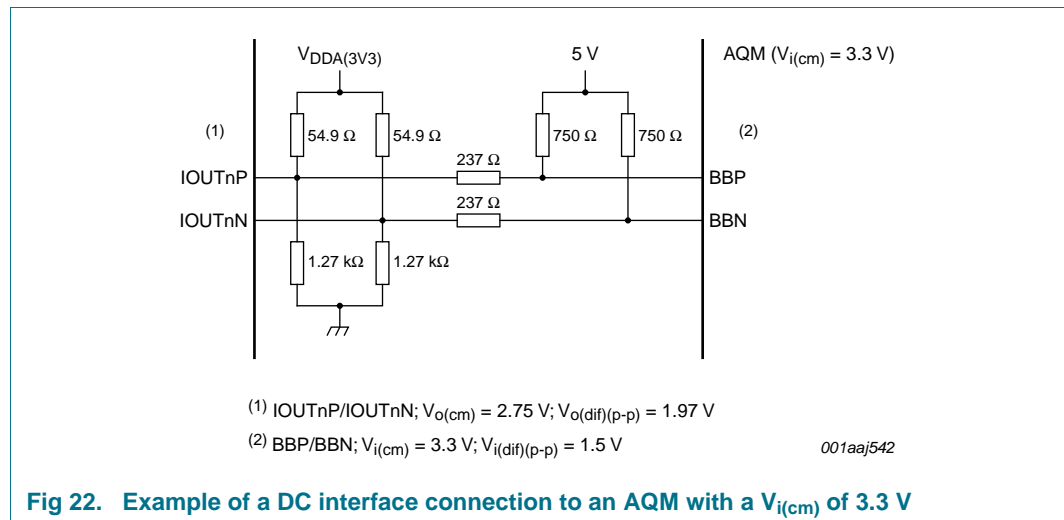

Fig 22. Example of a DC interface connection to an AQM with a $V_{i(cm)}$ of 3.3 V

The auxiliary DACs can be used to control the offset in a precise range or with precise steps.

Figure 23 is an example of a DC interface connected to an AQM with a common-mode input level ($V_{i(cm)}$) of 1.7 V when using auxiliary DACs.

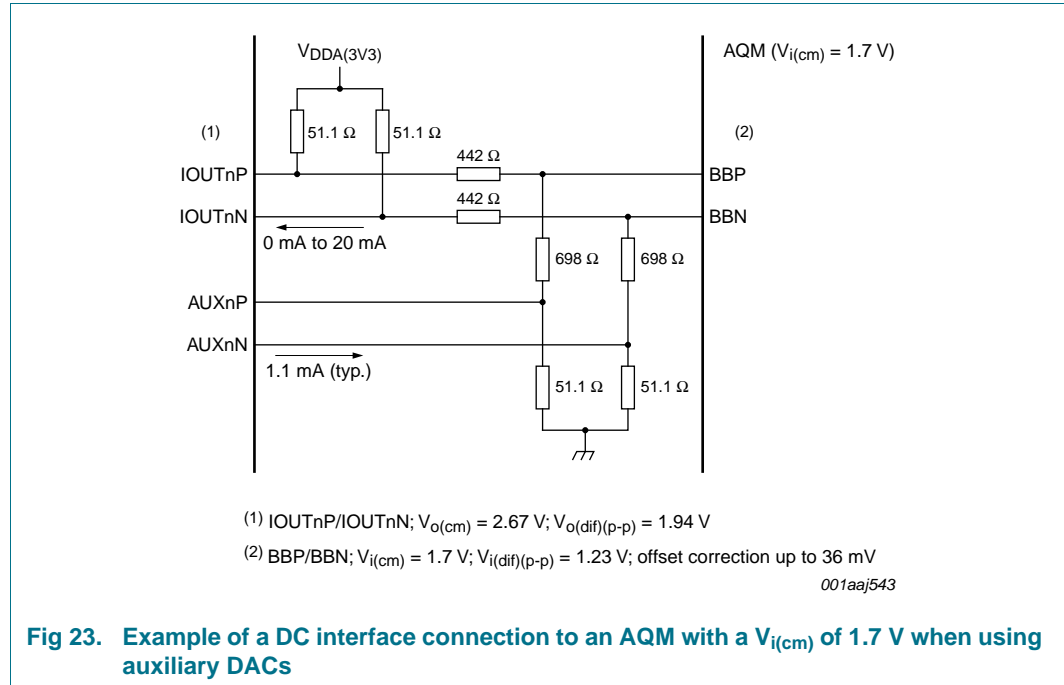
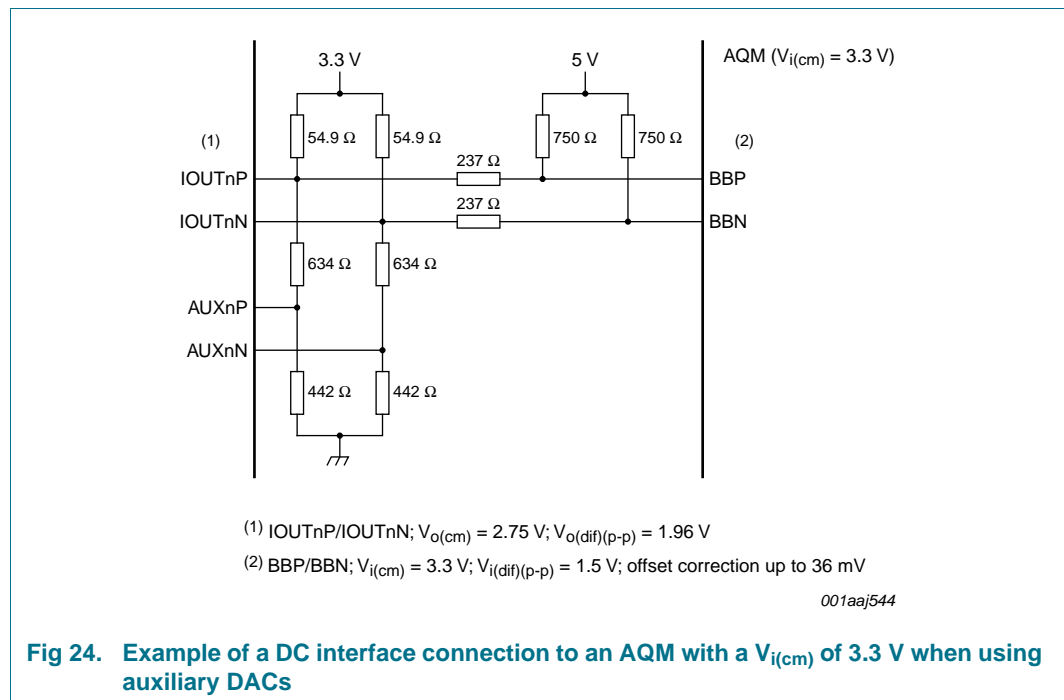

Figure 24 is an example of a DC interface connected to an AQM with a common-mode input level ($V_{i(cm)}$) of 3.3 V when using auxiliary DACs.



The constraints to adjusting the interface are the output compliance range of the DAC and the auxiliary DACs, the input common-mode level of the AQM, and the range of offset correction.

10.13.3 AC interface to an Analog Quadrature Modulator (AQM)

When the AQM common-mode voltage is close to ground, the DAC1008D750 must be AC-coupled and the auxiliary DACs are needed for offset correction.

Figure 25 is an example of a connection to an AQM with a common-mode input level ($V_{i(cm)}$) of 0.5 V when using auxiliary DACs.

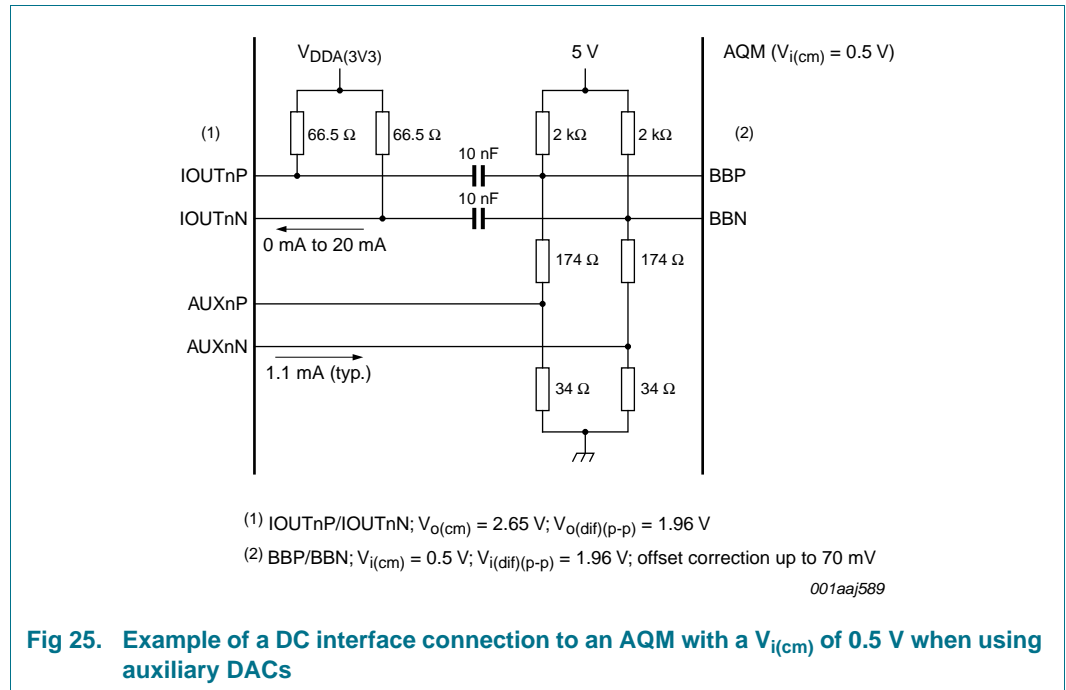

10.13.4 Phase correction

The Analog Quadrature Modulator which follows the DACs may have a phase imbalance which will result in undesired sidebands. By adjusting the phase between the I and Q channels, the spur can be reduced.

Without compensation the I and Q have a phase difference of $\Pi / 2$ (90°). The registers PHASECORR_CNTRL0 and PHASECORR_CNTRL1 located in register page 0 allow a phase variation from 75.7° to 104.3° . The two registers define a signed value that ranges from -512 to $+511$. The resulting phase compensation (in radians) is given by the equation: $\text{PHASE_CORR}[9:0] / 2048$.

10.14 Power and grounding

The power supplies should be decoupled with the following ground pins to optimize the decoupling:

- $V_{\text{DDA}(1V8)}$: pin 38 with pin 37; pin 44 with pin 43; pin 11 with pin 12; pin 17 with pin 18; pin 32 with pin 31

10.15 Configuration interface

10.15.1 Register description

DAC1008D750 implements indirect addressing using a page access method. The page-address is located at address 0x1F and is by default 0x00, which selects page 0 as the default page. For example, to access registers which configure the JESDRX, one must first activate page 4 by writing 0x04 to the page-address 0x1F.

The DAC1008D750 contains six different pages.

The device has no embedded power-on-reset feature. Driving the RESET_N pin to set the device to its default state is mandatory.

10.15.2 Detailed descriptions of registers

The register information has been provided in page form accompanied by a detailed description for each bit in the tables following the register allocation map of each page.

10.15.2.1 Page 0 allocation map description

Table 17. Page 0 register allocation map

Address	Register name	R/W	Bit definition									Default		
			b7	b6	b5	b4	b3	b2	b1	b0	Bin	Hex		
0	00h	COMMON	R/W	SPI_3W	SPI_RST	-	-	-	DF	PD_ALL	PD_GAP	10000100	84h	
1	01h	TXCFG	R/W	NCO_EN	NCO_LP_SEL	INV_SINE_EN	MODE[2:0]			INT_FIR[1:0]		00000001	01h	
2	02h	PLLCFG	R/W	PLL_PD	-	-	PLL_DIV[1:0]		PLL_PHASE[1:0]		PLL_POL	00000000	00h	
3	03h	FREQNCO_LSB	R/W	FREQ_NCO[7:0]									01100110	66h
4	04h	FREQNCO_LISB	R/W	FREQ_NCO[15:8]									01100110	66h
5	05h	FREQNCO_UISB	R/W	FREQ_NCO[23:16]									01100110	66h
6	06h	FREQNCO_MSB	R/W	FREQ_NCO[31:24]									00100110	26h
7	07h	PHINCO_LSB	R/W	PH_NCO[7:0]									00000000	00h
8	08h	PHINCO_MSB	R/W	PH_NCO[15:8]									00000000	00h
9	09h	DAC_A_CFG_1	R/W	DAC_A_PD	DAC_A_SLEEP	DAC_A_OFFSET[5:0]						00000000	00h	
10	0Ah	DAC_A_CFG_2	R/W	DAC_A_GAIN_COARSE[1:0]			DAC_A_GAIN_FINE[5:0]						01000000	40h
11	0Bh	DAC_A_CFG_3	R/W	DAC_A_GAIN_COARSE[3:2]			DAC_A_OFFSET[11:6]						11000000	C0h
12	0Ch	DAC_B_CFG_1	R/W	DAC_B_PD	DAC_B_SLEEP	DAC_B_OFFSET[5:0]						00000000	00h	
13	0Dh	DAC_B_CFG_2	R/W	DAC_B_GAIN_COARSE[1:0]			DAC_B_GAIN_FINE[5:0]						01000000	40h
14	0Eh	DAC_B_CFG_3	R/W	DAC_B_GAIN_COARSE[3:2]			DAC_B_OFFSET[11:6]						11000000	C0h
15	0Fh	DAC_CFG	R/W	-	-	-	-	-	-	MINUS_3DB	NOISE_SHAPER	00000000	00h	
17	11h	DAC_CURRENT_0	R/W	-	-	-	-	DAC_DIG_BIAS[2:0]			-	00000110	06h	
18	12h	DAC_CURRENT_1	R/W	-	-	-	-	DAC_MST_BIAS[2:0]			-	00000110	06h	
19	13h	DAC_CURRENT_2	R/W	DAC_DRV_BIAS[2:0]			-	DAC_SLV_BIAS[2:0]			-	01100110	66h	
20	14h	DAC_CURRENT_3	R/W	DAC_CK_BIAS[2:0]			-	DAC_CAS_BIAS[2:0]			-	01100110	66h	
21	15h	DAC_SEL_PH_FINE	R/W	-	-	-	-	-	SEL_PH_FINE[1:0]			00000010	02h	
22	16h	PHASECORR_CNTRL0	R/W	PHASE_CORR[7:0]									00000000	00h
23	17h	PHASECORR_CNTRL1	R/W	PHASE_CORR_ENABLE	-	-	-	-	PHASE_CORR[9:8]			00000000	00h	
26	1Ah	DAC_A_AUX_MSB	R/W	AUX_A[9:2]									10000000	80h
27	1Bh	DAC_A_AUX_LSB	R/W	AUX_A_PD	-	-	-	-	AUX_A[1:0]			00000000	00h	

Table 17. Page 0 register allocation map ...continued

Address	Register name	R/W	Bit definition								Default		
			b7	b6	b5	b4	b3	b2	b1	b0	Bin	Hex	
28	1Ch	DAC_B_AUX_MSB	R/W	AUX_B[9:2]								10000000	80h
29	1Dh	DAC_B_AUX_LSB	R/W	AUX_B_PD	-	-	-	-	-	AUX_B[1:0]		00000000	00h
31	1Fh	PAGE_ADDRESS	R/W	-	-	-	-	-	PAGE[2:0]			00000000	00h

10.15.2.2 Page 0 bit definition detailed description

Please refer to [Table 17](#) for a register overview for page 0. In the following tables, all the values emphasized in bold are the default values.

Table 18. COMMON register (address 00h) bit description

Default settings are shown highlighted.

Bit	Symbol	Access	Value	Description
7	SPI_3W	R/W		serial interface bus type
			0	4 wire SPI
			1	3 wire SPI
6	SPI_RST	R/W		serial interface reset
			0	no reset
			1	performs a reset on all registers except 0x00
2	DF	R/W		data format
			0	signed (two's compliment) format
			1	unsigned format
1	PD_ALL	R/W		power-down
			0	no action
			1	all circuits (digital and analog) are switched off
0	GAP_PD	R/W		internal bandgap power-down
			0	no action
			1	internal bandgap references are switched off

Table 19. TXCFG register (address 01h) bit description

Default settings are shown highlighted.

Bit	Symbol	Access	Value	Description
7	NCO_EN	R/W		NCO
			0	disabled (the NCO phase is reset to 0)
			1	enabled
6	NCO_LP_SEL	R/W		low-power NCO
			0	NCO may use all 32 bits
			1	NCO frequency and phase given by the five MSBs of the registers 06h and 08h respectively
5	INV_SINE_EN	R/W		$x / (\sin x)$ function
			0	disabled
			1	enabled
4 to 2	MODE[2:0]	R/W		modulation
			000	dual DAC: no modulation
			001	positive upper single sideband up-conversion
			010	positive lower single sideband up-conversion
			011	negative upper single sideband up-conversion
			100	negative lower single sideband up-conversion

Table 19. TXCFG register (address 01h) bit description ...continued

Default settings are shown highlighted.

Bit	Symbol	Access	Value	Description
1 to 0	INT_FIR[1:0]	R/W		interpolation
			00	no interpolation
			01	2×
			10	4×
			11	8×

Table 20. PLLCFG register (address 02h) bit description

Default settings are shown highlighted.

Bit	Symbol	Access	Value	Description
7	PLL_PD	R/W		PLL
			0	switched on
			1	switched off
6	-	R/W	0	undefined
5	-	R/W	0	must be written with '0'
4 to 3	PLL_DIV[1:0]	R/W		PLL divider factor
			00	2
			01	4
			10	8
2 to 1	PLL_PHASE[1:0]	R/W		PLL phase shift of f_s
			00	0°
			01	120°
			10	240°
			11	undefined
0	PLL_POL	R/W		clock edge of DAC (f_s)
			0	normal
			1	inverted

Table 21. FREQNCO_LSB register (address 03h) bit description

Bit	Symbol	Access	Value	Description
7 to 0	FREQ_NCO[7:0]	R/W	66h	lower 8 bits for the NCO frequency setting

Table 22. FREQNCO_LISB register (address 04h) bit description

Bit	Symbol	Access	Value	Description
7 to 0	FREQ_NCO[15:8]	R/W	66h	lower intermediate 8 bits for the NCO frequency setting

Table 23. FREQNCO_UISB register (address 05h) bit description

Bit	Symbol	Access	Value	Description
7 to 0	FREQ_NCO[23:16]	R/W	66h	upper intermediate 8 bits for the NCO frequency setting

Table 24. FREQNCO_MSB register (address 06h) bit description

Bit	Symbol	Access	Value	Description
7 to 0	FREQ_NCO[31:24]	R/W	26h	most significant 8 bits for the NCO frequency setting

Table 25. PHINCO_LSB register (address 07h) bit description

Bit	Symbol	Access	Value	Description
7 to 0	PH_NCO[7:0]	R/W	00h	lower 8 bits for the NCO phase setting

Table 26. PHINCO_MSB register (address 08h) bit description

Bit	Symbol	Access	Value	Description
7 to 0	PH_NCO[15:8]	R/W	00h	most significant 8 bits for the NCO phase setting

Table 27. DAC_A_CFG_1 register (address 09h) bit description

Default settings are shown highlighted.

Bit	Symbol	Access	Value	Description
7	DAC_A_PD	R/W		DAC A power
			0	on
			1	off
6	DAC_A_SLEEP	R/W		DAC A Sleep mode
			0	disabled
			1	enabled
5 to 0	DAC_A_OFFSET[5:0]	R/W	00h	lower 6 bits for the DAC A offset

Table 28. DAC_A_CFG_2 register (address 0Ah) bit description

Bit	Symbol	Access	Value	Description
7 to 6	DAC_A_GAIN_COARSE[1:0]	R/W	1h	least significant 2 bits for the DAC A gain setting for coarse adjustment
5 to 0	DAC_A_GAIN_FINE[5:0]	R/W	00h	the 6 bits for the DAC A gain setting for fine adjustment

Table 29. DAC_A_CFG_3 register (address 0Bh) bit description

Bit	Symbol	Access	Value	Description
7 to 6	DAC_A_GAIN_COARSE[3:2]	R/W	3h	most significant 2 bits for the DAC A gain setting for coarse adjustment
5 to 0	DAC_A_OFFSET[11:6]	R/W	00h	most significant 6 bits for the DAC A offset

Table 30. DAC_B_CFG_1 register (address 0Ch) bit description

Default settings are shown highlighted.

Bit	Symbol	Access	Value	Description
7	DAC_B_PD	R/W		DAC B power
			0	on
			1	off
6	DAC_B_SLEEP	R/W		DAC B Sleep mode
			0	disabled
			1	enabled
5 to 0	DAC_B_OFFSET[5:0]	R/W	00h	lower 6 bits for the DAC B offset

Table 31. DAC_B_CFG_2 register (address 0Dh) bit description

Bit	Symbol	Access	Value	Description
7 to 6	DAC_B_GAIN_COARSE[1:0]	R/W	1h	least significant 2 bits for the DAC B gain setting for coarse adjustment
5 to 0	DAC_B_GAIN_FINE[5:0]	R/W	00h	the 6 bits for the DAC B gain setting for fine adjustment

Table 32. DAC_B_CFG_3 register (address 0Eh) bit description

Bit	Symbol	Access	Value	Description
7 to 6	DAC_B_GAIN_COARSE[3:2]	R/W	3h	most significant 2 bits for the DAC B gain setting for coarse adjustment
5 to 0	DAC_B_OFFSET[11:6]	R/W	00h	most significant 6 bits for the DAC B offset

Table 33. DAC_CFG register (address 0Fh) bit description

Default settings are shown highlighted.

Bit	Symbol	Access	Value	Description
1	MINUS_3DB	R/W		NCO gain
			0	unity
			1	-3 dB
0	NOISE_SHAPER	R/W		noise shaper
			0	disabled
			1	enabled

Table 34. DAC_CURRENT_0 register (address 11h) bit description

Default settings are shown highlighted.

Bit	Symbol	Access	Value	Description
3 to 1	DAC_DIG_BIAS[2:0]	R/W	3h	bias current control (see Table 46)

Table 35. DAC_CURRENT_1 register (address 12h) bit description

Default settings are shown highlighted.

Bit	Symbol	Access	Value	Description
3 to 1	DAC_MST_BIAS[2:0]	R/W	3h	bias current control (see Table 46)

Table 36. DAC_CURRENT_2 register (address 13h) bit description

Default settings are shown highlighted.

Bit	Symbol	Access	Value	Description
7 to 5	DAC_DRV_BIAS[2:0]	R/W	3h	bias current control (see Table 46)
3 to 1	DAC_SLV_BIAS[2:0]	R/W	3h	bias current control (see Table 46)

Table 37. DAC_CURRENT_3 register (address 14h) bit description

Default settings are shown highlighted.

Bit	Symbol	Access	Value	Description
7 to 5	DAC_CK_BIAS[2:0]	R/W	3h	bias current control (see Table 46)
3 to 1	DAC_CAS_BIAS[2:0]	R/W	3h	bias current control (see Table 46)

Table 38. DAC_SEL_PH_FINE register (address 15h) bit description

Default settings are shown highlighted.

Bit	Symbol	Access	Value	Description
1 to 0	SEL_PH_FINE[1:0]	R/W	2h	fine DAC phase selection

Table 39. PHASECORR_CNTRL0 register (address 16h) bit description

Default settings are shown highlighted.

Bit	Symbol	Access	Value	Description
7 to 0	PHASE_CORR[7:0]	R/W	00h	LSB phase correction factor

Table 40. PHASECORR_CNTRL1 register (address 17h) bit description

Default settings are shown highlighted.

Bit	Symbol	Access	Value	Description
7	PHASE_CORR_ENABLE	R/W		phase correction
			0	disabled
			1	enabled
1 to 0	PHASE_CORR[9:8]	R/W	0h	MSB phase correction factor

Table 41. DAC_A_AUX_MSB register (address 1Ah) bit description

Bit	Symbol	Access	Value	Description
7 to 0	AUX_A[9:2]	R/W	80h	most significant 8 bits for auxiliary DAC A

Table 42. DAC_A_AUX_LSB register (address 1Bh) bit description

Default settings are shown highlighted.

Bit	Symbol	Access	Value	Description
7	AUX_A_PD	R/W		auxiliary DAC A power
			0	on
			1	off
1 to 0	AUX_A[1:0]	R/W	0h	lower 2 bits for auxiliary DAC A

Table 43. DAC_B_AUX_MSB register (address 1Ch) bit description

Bit	Symbol	Access	Value	Description
7 to 0	AUX_B[9:2]	R/W	80h	most significant 8 bits for auxiliary DAC B

Table 44. DAC_B_AUX_LSB register (address 1Dh) bit description

Default settings are shown highlighted.

Bit	Symbol	Access	Value	Description
7	AUX_B_PD	R/W		auxiliary DAC B power
			0	on
			1	off
1 to 0	AUX_B[1:0]	R/W	0h	lower 2 bits for auxiliary DAC B

Table 45. DAC_B_AUX_LSB register (address 1Dh) bit description

Default settings are shown highlighted.

Bit	Symbol	Access	Value	Description
2 to 0	PAGE[2:0]	R/W	0h	page address

Table 46. Bias current control table

Default settings are shown highlighted.

BIAS[2:0]	Deviation from nominal current
000	-30 %
001	...
010	...
011	0 %
100	...
101	...
110	...
111	+30 %

10.15.2.3 Page 1 allocation map description

Table 47. Page 1 register allocation map

Address	Register name	R/W	Bit definition									Default ^[1]	
			b7	b6	b5	b4	b3	b2	b1	b0	Bin	Hex	
0	00h	MDS_MAIN	R/W	MDS_EQCHECK[1:0]	MDS_RUN	MDS_NCO	MDS_SEL_LN23	MDS_32T_ENA	MDS_MASTER	MDS_ENA	00000100	04h	
1	01h	MDS_WIN_PERIOD_A	R/W	MDS_WIN_PERIOD_A[7:0]								10000000	80h
2	02h	MDS_WIN_PERIOD_B	R/W	MDS_WIN_PERIOD_B[7:0]								01000000	40h
3	03h	MDS_MISCCNTRL0	R/W	-	-	-	MDS_EVAL_ENA	MDS_PRERUN_ENA	MDS_PULSEWIDTH[2:0]			00010000	10h
4	04h	MDS_MAN_ADJUSTDLY	R/W	MDS_MAN	MDS_MAN_ADJUSTDLY[6:0]						01000000	40h	
5	05h	MDS_AUTO_CYCLES	R/W	MDS_AUTO_CYCLES[7:0]								10000000	80h
6	06h	MDS_MISCCNTRL1	R/W	MDS_SR_CKEN	MDS_SR_LOCKOUT	MDS_SR_LOCK	MDS_RELOCK	MDS_LOCK_DELAY[3:0]				00001111	0Fh
8	08h	MDS_ADJDELAY	R	-	MDS_ADJDELAY[6:0]						uuuuuuuu	uuh	
9	09h	MDS_STATUS0	R	EARLY	LATE	EQUAL	MDS_LOCK	EARLY_ERROR	LATE_ERROR	EQUAL_FOUND	MDS_ACTIVE	uuuuuuuu	uuh
10	0Ah	MDS_STATUS1	R	-	-	-	-	JD_ODD	MDS_PRERUN	MDS_LOCKOUT	MDS_LOCK	uuuuuuuu	uuh
31	1Fh	PAGE_ADDRESS	R/W	-	-	-	-	-	PAGE[2:0]			00000000	00h

[1] u = undefined at power-up or after reset.

10.15.2.4 Page 1 bit definition detailed description

Please refer to [Table 47](#) for a register overview and their default values. In the following tables, all the values emphasized in bold are the default values.

Table 48. MDS_MAIN register (address 00h) bit description

Default settings are shown highlighted.

Bit	Symbol	Access	Value	Description
7 to 6	MDS_EQCHECK[1:0]	R/W		lock mode
			00	lock when (early = 1 and late = 1)
			01	lock when (early = 1 and late = 1 and equal = 1)
			10	lock when equal = 1
			11	force_lock (equal-check = 1)
5	MDS_RUN	R/W		evaluation restart
			0	no action
4	MDS_NCO	R/W	1	transition from 0 to 1 restarts evaluation_counter
			0	no action
3	MDS_SEL_LN23	R/W	1	NCO synchronization
			0	no action
2	MDS_32T_ENA	R/W	1	NCO synchronization enabled
			0	no action
1	MDS_MASTER	R/W	1	synchronization reference
			0	use lane 1 enable as reference for synchronization
0	MDS_ENA	R/W	1	use lane 2/lane 3 enable as reference for synchronization
			0	disable MDS function
7 to 0	MDS_WIN_PERIOD_A[7:0]	R/W	80h	maximum delay
			0	maximum coarse delay is 16T_dclk
1	MDS_MASTER	R/W	1	maximum coarse delay is 32T_dclk
			0	maximum coarse delay is 32T_dclk
0	MDS_ENA	R/W	1	MDS mode
			0	slave mode
7 to 0	MDS_WIN_PERIOD_B[7:0]	R/W	40h	master mode
			0	enable MDS function

Table 49. MDS_WIN_PERIOD_A register (address 01h) bit description

Default settings are shown highlighted.

Bit	Symbol	Access	Value	Description
7 to 0	MDS_WIN_PERIOD_A[7:0]	R/W	80h	determines MDS window LOW-time

Table 50. MDS_WIN_PERIOD_B register (address 02h) bit description

Default settings are shown highlighted.

Bit	Symbol	Access	Value	Description
7 to 0	MDS_WIN_PERIOD_B[7:0]	R/W	40h	determines MDS window HIGH-time

Table 51. MDS_MISCCNTRL0 register (address 03h) bit description

Default settings are shown highlighted.

Bit	Symbol	Access	Value	Description
4	MDS_EVAL_ENA	R/W		MDS evaluation
			0	disabled
			1	enabled
3	MDS_PRERUN_ENA	R/W		automatic MDS start-up
			0	no mds_win/mds_ref generation in advance
			1	mds_win/mds_ref run-in before MDS evaluation
2 to 0	MDS_PULSEWIDTH[2:0]	R/W		width of MDS (in output clk-periods)
			000	1T
			001	2T
			010 to 111	$(\text{MDS_pulsewidth} - 1) \times 4T$

Table 52. MDS_MAN_ADJUSTDLY register (address 04h) bit description

Default settings are shown highlighted.

Bit	Symbol	Access	Value	Description
7	MDS_MAN	R/W		adjustment delay mode
			0	auto-control adjustment delays
			1	manual control adjustment delays
6 to 0	MDS_MAN_ADJUSTDLY[6:0]	R/W		adjustment delay value
			40h	if MDS_MAN = 0 then initial value adjustment delay
			-	if MDS_MAN = 1 then controls adjustment delay

Table 53. MDS_AUTO_CYCLES register (address 05h) bit description

Default settings are shown highlighted.

Bit	Symbol	Access	Value	Description
7 to 0	MDS_AUTO_CYCLES[7:0]	R/W	80h	number of evaluation cycles applied for MDS

Table 54. MDS_MISCCNTRL1 register (address 06h) bit description

Default settings are shown highlighted.

Bit	Symbol	Access	Value	Description
7	MDS_SR_CKEN	R/W		lock mode
			0	free-running mds_cken
			1	MDS_CKEN forced LOW
6	MDS_SR_LOCKOUT	R/W		lockout detector soft reset
			0	MDS_SR_LOCKOUT in use
			1	MDS_SR_LOCKOUT forced LOW
5	MDS_SR_LOCK	R/W		lock detector soft reset
			0	MDS_SR_LOCK in use
			1	MDS_SR_LOCK forced LOW

Table 54. MDS_MISCCNTRL1 register (address 06h) bit description ...continued

Default settings are shown highlighted.

Bit	Symbol	Access	Value	Description
4	MDS_RELOCK	R/W		relock mode
			0	no action
			1	relock when lockout occurs
3 to 0	MDS_LOCK_DELAY[3:0]	R/W	Fh	number of succeeding 'equal'-detections until lock

Table 55. MDS_ADJDELAY register (address 08h) bit description

Default settings are shown highlighted.

Bit	Symbol	Access	Value	Description
6 to 0	MDS_ADJDELAY[6:0]	R	-	actual value adjustment delay

Table 56. MDS_STATUS0 register (address 09h) bit description

Default settings are shown highlighted.

Bit	Symbol	Access	Value	Description
7	EARLY	R		early signal (sampled) from early-late detector
			0	false
			1	true
6	LATE	R		late signal (sampled) from early-late detector
			0	false
			1	true
5	EQUAL	R		equal signal (sampled) from early-late detector
			0	false
			1	true
4	MDS_LOCK	R		result equal check
			0	false
			1	true
3	EARLY_ERROR	R		adjustment delay maximum value stops the search
			0	false
			1	true
2	LATE_ERROR	R		adjustment delay minimum value stops the search
			0	false
			1	true
1	EQUAL_FOUND	R		evaluation logic has detected equal condition
			0	false
			1	true
0	MDS_ACTIVE	R		evaluation logic active
			0	false
			1	true

Table 57. MDS_STATUS1 register (address 0Ah) bit description*Default settings are shown highlighted.*

Bit	Symbol	Access	Value	Description
3	JD_ODD	R		MDS start mode
			0	MDS start aligned to cdi-even sample
			1	MDS start aligned to cdi-odd sample (only for ^2)
2	MDS_PRERUN	R		MDS pre-run phase active flag
			0	false
			1	true
1	MDS_LOCKOUT	R		MDS lockout detected flag
			0	false
			1	true
0	MDS_LOCK	R		MDS lock flag
			0	false
			1	true

Table 58. PAGE_ADDRESS register (address 1Fh) bit description*Default settings are shown highlighted.*

Bit	Symbol	Access	Value	Description
2 to 0	PAGE[2:0]	R/W	0h	page address

10.15.2.5 Page 2 allocation map description

Table 59. Page 2 register allocation map

Address		Register name	R/W	Bit definition								Default	
				b7	b6	b5	b4	b3	b2	b1	b0	Bin	Hex
0	00h	MAINCONTROL	R/W	-	-	FULL_RE_INIT	SYNC_INIT_LEVEL	0	0	FORCE_RESET_DCLK	FORCE_RESET_FCLK	00000011	03h
3	03h	JCLK_CNTRL	R/W	SR_CDI	-	CDI_MODE[1:0]		-	FCLK_POL	FCLK_SEL[1:0]		00000000	00h
4	04h	RST_EXT_FCLK	R/W	RST_EXT_FCLK_TIME[7:0]								00111111	3Fh
5	05h	RST_EXT_DCLK	R/W	RST_EXT_DCLK_TIME[7:0]								00100000	20h
6	06h	DCSMU_PREDIVCNT	R/W	DCSMU_PREDIVIDER[7:0]								00011110	1Eh
7	07h	PLL_CHARGETIME	R/W	PLL_CHARGE_TIME[7:0]								00110010	32h
8	08h	PLL_RUN_IN_TIME	R/W	PLL_RUNIN_TIME[7:0]								00110010	32h
9	09h	CA_RUN_IN_TIME	R/W	CA_RUNIN_TIME[7:0]								00000100	04h
22	16h	SET_VCM_VOLTAGE	R/W	-	-	-	-	SET_VCM[3:0]			00000010	02h	
23	17h	SET_SYNC	R/W	-	SET_SYNC_VCOM[2:0]		-	SET_SYNC_LEVEL[2:0]			01000011	43h	
27	1Bh	TYPE_ID	R	DAC	FRONTEND[1:0]		DUAL	DSP		BIT_RES[1:0]		11011111	DFh
28	1Ch	DAC_VERSION	R	DAC_VERSION_ID[7:0]								00000001	01h
29	1Dh	DIG_VERSION	R	DIG_VERSION_ID[7:0]								00000010	02h
30	1Eh	JRX_ANA_VERSION	R	JRX_ANA_VERSION_ID[7:0]								00000010	02h
31	1Fh	PAGE_ADDRESS	R/W	-	-	-	-	-	PAGE[2:0]			00000000	00h

10.15.2.6 Page 2 bit definition detailed description

Please refer to [Table 59](#) for a register overview and their default values. In the following tables, all the values emphasized in bold are the default values.

Table 60. MAINCONTROL register (address 00h) bit description

Default settings are shown highlighted.

Bit	Symbol	Access	Value	Description
5	FULL_RE_INIT	R/W		initialization
			0	quick reinitialization
			1	full reinitialization
4	SYNC_INIT_LEVEL	R/W		synchronization
			0	synchronization starts with '0'
			1	synchronization starts with '1'
3	-	R/W		must be written with '0'
2	-	R/W		must be written with '0'
1	FORCE_RESET_DCLK	R/W		reset_dclk
			0	release reset_dclk
			1	force reset_dclk
0	FORCE_RESET_FCLK	R/W		reset_fclk
			0	release reset_fclk
			1	force reset_fclk

Table 61. JCLK_CNTRL register (address 03h) bit description

Default settings are shown highlighted.

Bit	Symbol	Access	Value	Description
7	SR_CDI	R/W		cdi reset
			0	no action
			1	soft reset cdi
5 to 4	CDI_MODE[1:0]	R/W		cdi mode
			00	cdi_mode 0 (^2 modes)
			01	cdi_mode 1 (^4 modes)
			10	cdi_mode 2 (^8 modes)
			11	reserved
2	FCLK_POL	R/W		f _{clk} polarity
			0	no action
			1	invert polarity
1 to 0	FCLK_SEL[1:0]	R/W		f _{clk} clock source
			00	dclk × 2
			01	dclk
			10	dclk_div2; running
			11	dclk_div2; reset dclk_div2 divider

Table 62. RST_EXT_FCLK register (address 04h) bit description

Default settings are shown highlighted.

Bit	Symbol	Access	Value	Description
7 to 0	RST_EXT_FCLK_TIME[7:0]	R/W	3Fh	specifies extension time reset_fclk in f_{clk} periods

Table 63. RST_EXT_DCLK register (address 05h) bit description

Default settings are shown highlighted.

Bit	Symbol	Access	Value	Description
7 to 0	RST_EXT_DCLK_TIME[7:0]	R/W	20h	specifies extension time reset_dclk (in dclk-periods)

Table 64. DCSMU_PREDIVCNT register (address 06h) bit description

Default settings are shown highlighted.

Bit	Symbol	Access	Value	Description
7 to 0	DCSMU_PREDIVIDER[7:0]	R/W	1Eh	value used by dcsmu predivider (at f_{clk})

Table 65. PLL_CHARGETIME register (address 07h) bit description

Default settings are shown highlighted.

Bit	Symbol	Access	Value	Description
7 to 0	PLL_CHARGE_TIME[7:0]	R/W	32h	PLL charge time (at $f_{clk}/DCSMU_PREDIVIDER[7:0]$)

Table 66. PLL_RUN_IN_TIME register (address 08h) bit description

Default settings are shown highlighted.

Bit	Symbol	Access	Value	Description
7 to 0	PLL_RUNIN_TIME[7:0]	R/W	32h	PLL run in time (at $f_{clk}/DCSMU_PREDIVIDER[7:0]$)

Table 67. CA_RUN_IN_TIME register (address 09h) bit description

Default settings are shown highlighted.

Bit	Symbol	Access	Value	Description
7 to 0	CA_RUNIN_TIME[7:0]	R/W	04h	clock alignment run in time (at $f_{clk}/DCSMU_PREDIVIDER[7:0]$)

Table 68. SET_VCM_VOLTAGE register (address 16h) bit description

Default settings are shown highlighted.

Bit	Symbol	Access	Value	Description
3 to 0	SET_VCM[3:0]	R/W	02h	set lane common-mode voltage (see Table 75)

Table 69. SET_SYNC register (address 17h) bit description

Default settings are shown highlighted.

Bit	Symbol	Access	Value	Description
6 to 4	SET_SYNC_VCOM[2:0]	R/W	4h	set synchronization transmitter common-mode level (see Table 76)
2 to 0	SET_SYNC_LEVEL[2:0]	R/W	3h	set synchronization transmitter output level swing (see Table 77)

Table 70. TYPE_ID register (address 1Bh) bit description

Default settings are shown highlighted.

Bit	Symbol	Access	Value	Description
7	DAC	R		part type
			0	ADC
			1	DAC
6 to 5	FRONTEND [1:0]	R		input format
			00	CMOS
			01	LVDS
			10	JESD204A
			11	reserved
4	DUAL	R		converter structure
			0	single
			1	dual
3 to 2	DSP	R		digital processing
			00	none
			01	upsampling filters
			10	single sideband modulator
			11	upsampling filters + single sideband modulator
1 to 0	BIT_RES[1:0]	R		resolution
			00	16 bits
			01	14 bits
			10	12 bits
			11	10 bits

Table 71. DAC_VERSION register (address 1Ch) bit description

Default settings are shown highlighted.

Bit	Symbol	Access	Value	Description
7 to 0	DAC_VERSION_ID[7:0]	R	01h	dual DAC core version

Table 72. DIG_VERSION register (address 1Dh) bit description

Default settings are shown highlighted.

Bit	Symbol	Access	Value	Description
7 to 0	DIG_VERSION_ID[7:0]	R	02h	digital version

Table 73. JRX_ANA_VERSION register (address 1Eh) bit description

Default settings are shown highlighted.

Bit	Symbol	Access	Value	Description
7 to 0	JRX_ANA_VERSION_ID[7:0]	R	02h	analog deserializer version

Table 74. PAGE_ADDRESS register (address 1Fh) bit description

Default settings are shown highlighted.

Bit	Symbol	Access	Value	Description
2 to 0	PAGE[2:0]	R/W	0h	page address

Table 75. Lane common-mode voltage adjustment

Register 16h: SET_VCM_VOLTAGE		
Decimal	SET_VCM_VOLTAGE	V _{com} (V)
15	1111	1.40
14	1110	1.36
13	1101	1.31
12	1100	1.26
11	1011	1.21
10	1010	1.16
9	1001	1.12
8	1000	1.07
7	0111	1.02
6	0110	0.97
5	0101	0.92
4	0100	0.87
3	0011	0.82
2	0010	0.78
1	0001	0.73
0	0000	0.68

Table 76. SYNC common-mode voltage adjustment

Register 17h: SET_SYNC		
Decimal	SET_SYNC_VCOM[2:0]	V _{com} (V)
7	111	1.46
6	110	1.36
5	101	1.27
4	100	1.17
3	011	1.07
2	010	0.98
1	001	0.88
0	000	0.79

Table 77. SYNC swing voltage adjustment

Register 17h: SET_SYNC		
Decimal	SET_SYNC_LEVEL[2:0]	Single-ended output voltage (V)
7	111	0.48
6	110	0.42
5	101	0.36
4	100	0.30
3	011	0.24
2	010	0.18
1	001	0.12
0	000	0.06

10.15.2.7 Page 4 allocation map description

Table 78. Page 4 register allocation map

Address	Register name	R/W	Bit definition									Default	
			b7	b6	b5	b4	b3	b2	b1	b0	Bin	Hex	
0	00h	SR_DLP_0	R/W	SR_SWA_LN3	SR_SWA_LN2	SR_SWA_LN1	SR_SWA_LN0	SR_CA_LN3	SR_CA_LN2	SR_CA_LN1	SR_CA_LN0	00000000	00h
1	01h	SR_DLP_1	R/W	SR_CNTRL_LN3	SR_CNTRL_LN2	SR_CNTRL_LN1	SR_CNTRL_LN0	SR_DEC_LN3	SR_DEC_LN2	SR_DEC_LN1	SR_DEC_LN0	00000000	00h
2	02h	FORCE_LOCK	R/W	FORCE_LOCK_LN3	FORCE_LOCK_LN2	FORCE_LOCK_LN1	FORCE_LOCK_LN0	-	-	-	SR_ILA	00000000	00h
3	03h	MAN_LOCK_LN_1_0	R/W	MAN_LOCK_LN1[3:0]				MAN_LOCK_LN0[3:0]				00000000	00h
4	04h	MAN_LOCK_2_0	R/W	MAN_LOCK_LN3[3:0]				MAN_LOCK_LN2[3:0]				00000000	00h
5	05h	CA_CNTRL	R/W	WORD_SWAP_LN3	WORD_SWAP_LN2	WORD_SWAP_LN1	WORD_SWAP_LN0	SELECT_RF_F10_LN3	SELECT_RF_F10_LN2	SELECT_RF_F10_LN1	SELECT_RF_F10_LN0	00000000	00h
6	06h	SCR_CNTRL	R/W	MAN_SCR_LN3	MAN_SCR_LN2	MAN_SCR_LN1	MAN_SCR_LN0	FORCE_SCR_LN3	FORCE_SCR_LN2	FORCE_SCR_LN1	FORCE_SCR_LN0	00000000	00h
7	07h	ILA_CNTRL	R/W	SEL_421_211	SEL_ILA[1:0]		SEL_LOCK[2:0]			SUP_LANE_SYN	EN_SCR	10000011	83h
8	08h	FORCE_ALIGN	R/W	-	-	-	-	-	-	DYN_ALIGN_ENA	FORCE_ALIGN	00000000	00h
9	09h	MAN_ALIGN_LN_0_1	R/W	MAN_ALIGN_LN1[3:0]				MAN_ALIGN_LN0[3:0]				00000000	00h
10	0Ah	MAN_ALIGN_LN_2_3	R/W	MAN_ALIGN_LN3[3:0]				MAN_ALIGN_LN2[3:0]				00000000	00h
11	0Bh	FA_ERR_HANDLING	R/W	SEL_KOUT_UNEXP_LN23[1:0]		SEL_KOUT_UNEXP_LN10[1:0]		SEL_NIT_ERR_LN23[1:0]		SEL_NIT_ERR_LN10[1:0]		00000000	00h
12	0Ch	SYNCOUT_MODE	R/W	SEL_RE_INIT[2:0]			SYNC_POL	SEL_SYNC[3:0]				00000000	00h
13	0Dh	LANE_POLARITY	R/W	-	-	-	-	POL_LN3	POL_LN2	POL_LN1	POL_LN0	00000000	00h
14	0Eh	LANE_SELECT	R/W	LANE_SEL_LN3[1:0]		LANE_SEL_LN2[1:0]		LANE_SEL_LN1[1:0]		LANE_SEL_LN0[1:0]		11100100	E4h
16	10h	SOFT_RESET_SCRAMBLER	R/W	-	-	-	-	SR_SCR_LN3	SR_SCR_LN2	SR_SCR_LN1	SR_SCR_LN0	00000000	00h
17	11h	INIT_SCR_S15T8_LN0	R/W	INIT_VALUE_S15_S8_LN0[7:0]								00000000	00h

Table 78. Page 4 register allocation map ...continued

Address		Register name	R/W	Bit definition								Default		
				b7	b6	b5	b4	b3	b2	b1	b0	Bin	Hex	
18	12h	INIT_SCR_S7T1_LN0	R/W	-	INIT_VALUE_S7_S1_LN0[6:0]								00000000	00h
19	13h	INIT_SCR_S15T8_LN1	R/W	INIT_VALUE_S15_S8_LN1[7:0]								00000000	00h	
20	14h	INIT_SCR_S7T1_LN1	R/W	-	INIT_VALUE_S7_S1_LN1[6:0]								00000000	00h
21	15h	INIT_SCR_S15T8_LN2	R/W	INIT_VALUE_S15_S8_LN2[7:0]								00000000	00h	
22	16h	INIT_SCR_S7T1_LN2	R/W	-	INIT_VALUE_S7_S1_LN2[6:0]								00000000	00h
23	17h	INIT_SCR_S15T8_LN3	R/W	INIT_VALUE_S15_S8_LN3[7:0]								00000000	00h	
24	18h	INIT_SCR_S7T1_LN3	R/W	-	INIT_VALUE_S7_S1_LN3[6:0]								00000000	00h
25	19h	INIT_ILA_BUFPTR_LN01	R/W	INIT_ILA_BUFPTR_LN1[3:0]				INIT_ILA_BUFPTR_LN0[3:0]				10001000	88h	
26	1Ah	INIT_ILA_BUFPTR_LN23	R/W	INIT_ILA_BUFPTR_LN3[3:0]				INIT_ILA_BUFPTR_LN2[3:0]				10001000	88h	
27	1Bh	ERROR_HANDLING	R/W	-	NAD_ERR_CORR	KUX_CORR	NAD_CORR	CORR_MODE[1:0]		IMPL_ALT	IGNORE_ERR	00000000	00h	
28	1Ch	REINIT_CNTRL	R/W	REINIT_ILA_LN3	REINIT_ILA_LN2	REINIT_ILA_LN1	REINIT_ILA_LN0	RESYNC_O_L_LN3	RESYNC_O_L_LN2	RESYNC_O_L_LN1	RESYNC_O_L_LN0	00000000	00h	
31	1Fh	PAGE_ADDRESS	R/W	-	-	-	-	-	PAGE[2:0]			00000000	00h	

10.15.2.8 Page 4 bit definition detailed description

Please refer to [Table 78](#) for a register overview and their default values. In the following tables, all the values emphasized in bold are the default values.

Table 79. SR_DLP_0 register (address 00h) bit description

Default settings are shown highlighted.

Bit	Symbol	Access	Value	Description
7	SR_SWA_LN3	R/W	0	soft reset sync_word_alignment lane 3
6	SR_SWA_LN2	R/W	0	soft reset sync_word_alignment lane 2
5	SR_SWA_LN1	R/W	0	soft reset sync_word_alignment lane 1
4	SR_SWA_LN0	R/W	0	soft reset sync_word_alignment lane 0
3	SR_CA_LN3	R/W	0	soft reset clock_alignment lane 3
2	SR_CA_LN2	R/W	0	soft reset clock_alignment lane 2
1	SR_CA_LN1	R/W	0	soft reset clock_alignment lane 1
0	SR_CA_LN0	R/W	0	soft reset clock_alignment lane 0

Table 80. SR_DLP_1 register (address 01h) bit description

Default settings are shown highlighted.

Bit	Symbol	Access	Value	Description
7	SR_CNTRL_LN3	R/W	0	soft reset controller lane 3
6	SR_CNTRL_LN2	R/W	0	soft reset controller lane 2
5	SR_CNTRL_LN1	R/W	0	soft reset controller lane 1
4	SR_CNTRL_LN0	R/W	0	soft reset controller lane 0
3	SR_DEC_LN3	R/W	0	soft reset decoder_10b8b lane 3
2	SR_DEC_LN2	R/W	0	soft reset decoder_10b8b lane 2
1	SR_DEC_LN1	R/W	0	soft reset decoder_10b8b lane 1
0	SR_DEC_LN0	R/W	0	soft reset decoder_10b8b lane 0

Table 81. FORCE_LOCK register (address 02h) bit description

Default settings are shown highlighted.

Bit	Symbol	Access	Value	Description
7	FORCE_LOCK_LN3	R/W		lane 3 lock mode
			0	automatic lock sync_word_alignment lane 3
6	FORCE_LOCK_LN2	R/W	1	manual lock sync_word_alignment lane 3
			0	automatic lock sync_word_alignment lane 2
5	FORCE_LOCK_LN1	R/W	1	manual lock sync_word_alignment lane 2
			0	automatic lock sync_word_alignment lane 1
4	FORCE_LOCK_LN0	R/W	1	manual lock sync_word_alignment lane 1
			0	automatic lock sync_word_alignment lane 0
			1	manual lock sync_word_alignment lane 0
			0	automatic lock sync_word_alignment lane 0

Table 81. FORCE_LOCK register (address 02h) bit description ...continued

Default settings are shown highlighted.

Bit	Symbol	Access	Value	Description
0	SR_ILA	R/W		soft reset inter-lane alignment
			0	no action
			1	reset

Table 82. MAN_LOCK_LN_1_0 register (address 03h) bit description

Default settings are shown highlighted.

Bit	Symbol	Access	Value	Description
7 to 4	MAN_LOCK_LN1[3:0]	R/W	0h	manual lock setting synchronization word alignment lane 1
3 to 0	MAN_LOCK_LN0[3:0]	R/W	0h	manual lock setting synchronization word alignment lane 0

Table 83. MAN_LOCK_2_0 register (address 04h) bit description

Default settings are shown highlighted.

Bit	Symbol	Access	Value	Description
7 to 4	MAN_LOCK_LN3[3:0]	R/W	0h	manual lock setting synchronization word alignment lane 3
3 to 0	MAN_LOCK_LN2[3:0]	R/W	0h	manual lock setting synchronization word alignment lane 2

Table 84. CA_CNTRL register (address 05h) bit description

Bit	Symbol	Access	Value	Description
7	WORD_SWAP_LN3	R/W		lane 3 bit swapping
			0	dout_ca_ln3[7:0] = din_ca_ln3[7:0]
			1	dout_ca_ln3[7:0] = din_ca_ln3[0:7]
6	WORD_SWAP_LN2	R/W		lane 2 bit swapping
			0	dout_ca_ln2[7:0] = din_ca_ln2[7:0]
			1	dout_ca_ln2[7:0] = din_ca_ln2[0:7]
5	WORD_SWAP_LN1	R/W		lane 1 bit swapping
			0	dout_ca_ln1[7:0] = din_ca_ln1[7:0]
			1	dout_ca_ln1[7:0] = din_ca_ln1[0:7]
4	WORD_SWAP_LN0	R/W		lane 0 bit swapping
			0	dout_ca_ln0[7:0] = din_ca_ln0[7:0]
			1	dout_ca_ln0[7:0] = din_ca_ln0[0:7]
3	SELECT_RF_F10_LN3	R/W		lane 3 sampling mode
			0	din_ca_ln3 sampled at falling edge f10_ln3
			1	din_ca_ln3 sampled at rising edge f10_ln3
2	SELECT_RF_F10_LN2	R/W		lane 2 sampling mode
			0	din_ca_ln2 sampled at falling edge f10_ln2
			1	din_ca_ln2 sampled at rising edge f10_ln2

Table 84. CA_CNTRL register (address 05h) bit description ...continued

Bit	Symbol	Access	Value	Description
1	SELECT_RF_F10_LN1	R/W		lane 1 sampling mode
			0	din_ca_In1 sampled at falling edge f10_In1
0	SELECT_RF_F10_LN0	R/W	1	din_ca_In1 sampled at rising edge f10_In1
			0	din_ca_In0 sampled at falling edge f10_In0
			1	din_ca_In0 sampled at rising edge f10_In0

Table 85. SCR_CNTRL register (address 06h) bit description

Bit	Symbol	Access	Value	Description
7	MAN_SCR_LN3	R/W		lane 3 manual scrambling
			0	scrambling lane 3 off (when force_scr_In3 = 1)
6	MAN_SCR_LN2	R/W	1	scrambling lane 3 on (when force_scr_In3 = 1)
			0	scrambling lane 2 off (when force_scr_In2 = 1)
5	MAN_SCR_LN1	R/W	1	scrambling lane 2 on (when force_scr_In2 = 1)
			0	scrambling lane 1 off (when force_scr_In1 = 1)
4	MAN_SCR_LN0	R/W	1	scrambling lane 1 on (when force_scr_In1 = 1)
			0	scrambling lane 0 off (when force_scr_In0 = 1)
3	FORCE_SCR_LN3	R/W	1	scrambling lane 0 on (when force_scr_In0 = 1)
			0	scrambling lane 3 depends on lock_In3 and en_scr
2	FORCE_SCR_LN2	R/W	1	scrambling lane 3 depends on man_scr_In3
			0	scrambling lane 2 depends on lock_In2 and en_scr
1	FORCE_SCR_LN1	R/W	1	scrambling lane 2 depends on man_scr_In2
			0	scrambling lane 1 depends on lock_In1 and en_scr
0	FORCE_SCR_LN0	R/W	1	scrambling lane 1 depends on man_scr_In1
			0	scrambling lane 0 depends on lock_In0 and en_scr
			1	scrambling lane 0 depends on man_scr_In0

Table 86. ILA_CNTRL register (address 07h) bit description

Bit	Symbol	Access	Value	Description
7	SEL_421_211	R/W		inter-lane alignment mode
			0	inter-lane alignment based on lane 3 : lane 2 and/or lane 1 : lane 0
			1	inter-lane alignment based on In3 : In0
6 to 5	SEL_ILA[1:0]	R/W		inter-lane alignment trigger mode
			00	inter-lane alignment is done after receiving 1 /A/-symbol
			01	inter-lane alignment is done after receiving 2 /A/-symbols
			10	inter-lane alignment is done after receiving 3 /A/-symbols
			11	inter-lane alignment is done after receiving 4 /A/-symbols
4 to 2	SEL_LOCK[2:0]	R/W		inter-lane alignment start mode
			000	inter-lane alignment may start only if all (4 or 2) lanes are locked
			001	inter-lane alignment may start if one of the (4 or 2) lanes are locked
			010	inter-lane alignment may start if lane 0 is locked
			011	inter-lane alignment may start if lane 1 is locked
			100	inter-lane alignment may start if lane 2 is locked
			101	inter-lane alignment may start if lane 3 is locked
			1	SUP_LANE_SYN
			0	inter-lane alignment synchronization disabled
			1	inter-lane alignment synchronization enabled
0	EN_SCR	R/W		data descrambling
			0	disabled
			1	enabled

Table 87. FORCE_ALIGN register (address 08h) bit description

Bit	Symbol	Access	Value	Description
1	DYN_ALIGN_ENA	R/W		dynamic re-alignment mode
			0	no dynamic re-alignment
			1	dynamic re-alignment (and monitoring) enabled
0	FORCE_ALIGN	R/W		lane alignment mode
			0	automatic lane alignment based on /A/ symbols
			1	manual lane alignment based on man_align_Inx

Table 88. MAN_ALIGN_LN_0_1 register (address 09h) bit description

Bit	Symbol	Access	Value	Description
7 to 4	MAN_ALIGN_LN1[3:0]	R/W	0h	indicates alignment data-delay for lane 1 [1..15]
3 to 0	MAN_ALIGN_LN0[3:0]	R/W	0h	indicates alignment data-delay for lane 0 [1..15]

Table 89. MAN_ALIGN_LN_2_3 register (address 0Ah) bit description

Bit	Symbol	Access	Value	Description
7 to 4	MAN_ALIGN_LN3[3:0]	R/W	0h	indicates alignment data-delay for lane 3 [1..15]
3 to 0	MAN_ALIGN_LN2[3:0]	R/W	0h	indicates alignment data-delay for lane 2 [1..15]

Table 90. FA_ERR_HANDLING register (address 0Bh) bit description

Default settings are shown highlighted.

Bit	Symbol	Access	Value	Description
7 to 6	SEL_KOUT_UNEXP_LN23[1:0]	R/W		lane 2/lane 3 unexpected /K/ error handling
			00	unexpected /K/ in lane 2 or lane 3 error_handling
			01	unexpected /K/ in lane 2 and lane 3 error_handling
			10	unexpected /K/ in lane 2 error_handling
			11	unexpected /K/ in lane 3 error_handling
5 to 4	SEL_KOUT_UNEXP_LN10[1:0]	R/W		lane 0/lane 1 unexpected /K/ error handling
			00	unexpected /K/ in lane 0 or lane 1 error_handling
			01	unexpected /K/ in lane 0 and lane 1 error_handling
			10	unexpected /K/ in lane 0 error_handling
			11	unexpected /K/ in lane 1 error_handling
3 to 2	SEL_NIT_ERR_LN23[1:0]	R/W		lane 2/lane 3 nit-error handling
			00	nit-errors in lane 2 or lane 3 error_handling
			01	not-in-table errors lane 2 and lane 3 error_handling
			10	not-in-table errors in lane 2 error_handling
			11	not-in-table errors in lane 3 error_handling
1 to 0	SEL_NIT_ERR_LN10[1:0]	R/W		lane 0/lane 1 nit-error handling
			00	nit-errors in lane 0 or lane 1 error_handling
			01	not-in-table errors lane 0 and lane 1 error_handling
			10	not-in-table errors in lane 0 error_handling
			11	not-in-table errors in lane 1 error_handling

Table 91. SYNCOUT_MODE register (address 0Ch) bit description

Default settings are shown highlighted.

Bit	Symbol	Access	Value	Description
7 to 5	SEL_RE_INIT[2:0]	R/W		reinitialization mode
			000	i_re_init when 1 of the lane_rst's is active
			001	i_re_init when rst_In0 or rst_In1 is active
			010	i_re_init when rst_In2 or rst_In3 is active
			011	i_re_init when rst_In0 is active
			100	i_re_init when rst_In1 is active
			101	i_re_init when rst_In2 is active
			110	i_re_init when rst_In3 is active
			111	i_re_init remains '0'
			4	SYNC_POL
0	sync_out is active when LOW			
1	sync_out is active when HIGH			
3 to 0	SEL_SYNC[3:0]	R/W		synchronization mode
			0000	sync when one of the four lane_syncs is active
			0001	sync when all four lane_syncs are active
			0010	sync when sync_In0 or sync_In1 is active
			0011	sync when both sync_In0 and sync_In1 are active
			0100	sync when sync_In2 or sync_In3 is active
			0101	sync when both sync_In2 and sync_In3 are active
			0110	sync when sync_In0 is active
			0111	sync when sync_In1 is active
			1000	sync when sync_In2 is active
			1001	sync when sync_In3 is active
			1010	sync remains fixed '1'
			other	sync remains fixed '0'

Table 92. LANE_POLARITY register (address 0Dh) bit description

Bit	Symbol	Access	Value	Description
3	POL_LN3	R/W		lane 3 data polarity
			0	no action
			1	invert all data bits of lane 3
2	POL_LN2	R/W		lane 2 data polarity
			0	no action
			1	invert all data bits of lane 2
1	POL_LN1	R/W		lane 1 data polarity
			0	no action
			1	invert all data bits of lane 1
0	POL_LN0	R/W		lane 0 data polarity
			0	no action
			1	invert all data bits of lane 0

Table 93. LANE_SELECT register (address 0Eh) bit description

Default settings are shown highlighted.

Bit	Symbol	Access	Value	Description
7 to 6	LANE_SEL_LN3[1:0]	R/W		lane 3 data mapping
			00	ila_in_ln3 = lane_ln0 (dout and controls)
			01	ila_in_ln3 = lane_ln1 (dout and controls)
			10	ila_in_ln3 = lane_ln2 (dout and controls)
			11	ila_in_ln3 = lane_ln3 (dout and controls)
5 to 4	LANE_SEL_LN2[1:0]	R/W		lane 2 data mapping
			00	ila_in_ln2 = lane_ln0 (dout and controls)
			01	ila_in_ln2 = lane_ln1 (dout and controls)
			10	ila_in_ln2 = lane_ln2 (dout and controls)
			11	ila_in_ln2 = lane_ln3 (dout and controls)
3 to 2	LANE_SEL_LN1[1:0]	R/W		lane 1 data mapping
			00	ila_in_ln1 = lane_ln0 (dout and controls)
			01	ila_in_ln1 = lane_ln1 (dout and controls)
			10	ila_in_ln1 = lane_ln2 (dout and controls)
			11	ila_in_ln1 = lane_ln3 (dout and controls)
1 to 0	LANE_SEL_LN0[1:0]	R/W		lane 0 data mapping
			00	ila_in_ln0 = lane_ln0 (dout and controls)
			01	ila_in_ln0 = lane_ln1 (dout and controls)
			10	ila_in_ln0 = lane_ln2 (dout and controls)
			11	ila_in_ln0 = lane_ln3 (dout and controls)

Table 94. SOFT_RESET_SCRAMBLER register (address 10h) bit description

Bit	Symbol	Access	Value	Description
3	SR_SCR_LN3	R/W		lane 3 scrambler reset
			0	no action
			1	soft_reset scrambler of lane 3
2	SR_SCR_LN2	R/W		lane 2 scrambler reset
			0	no action
			1	soft_reset scrambler of lane 2
1	SR_SCR_LN1	R/W		lane 1 scrambler reset
			0	no action
			1	soft_reset scrambler of lane 1
0	SR_SCR_LN0	R/W		lane 0 scrambler reset
			0	no action
			1	soft_reset scrambler of lane 0

Table 95. INIT_SCR_S15T8_LN0 register (address 11h) bit description

Bit	Symbol	Access	Value	Description
7 to 0	INIT_VALUE_S15_S8_LN0[7:0]	R/W	00h	initialization value for lane 0 descrambler bits s15 : s8

Table 96. INIT_SCR_S7T1_LN0 (address 12h) bit description

Bit	Symbol	Access	Value	Description
6 to 0	INIT_VALUE_S7_S1_LN0[6:0]	R/W	00h	initialization value for lane 0 descrambler bits s7 : s1

Table 97. INIT_SCR_S15T8_LN1 register (address 13h) bit description

Bit	Symbol	Access	Value	Description
7 to 0	INIT_VALUE_S15_S8_LN1[7:0]	R/W	00h	initialization value for lane 1 descrambler bits s15 : s8

Table 98. INIT_SCR_S7T1_LN1 register (address 14h) bit description

Bit	Symbol	Access	Value	Description
6 to 0	INIT_VALUE_S7_S1_LN1[6:0]	R/W	00h	initialization value for lane 1 descrambler bits s7 : s1

Table 99. INIT_SCR_S15T8_LN2 register (address 15h) bit description

Bit	Symbol	Access	Value	Description
7 to 0	INIT_VALUE_S15_S8_LN2[7:0]	R/W	00h	initialization value for lane 2 descrambler bits s15 : s8

Table 100. INIT_SCR_S7T1_LN2 register (address 16h) bit description

Bit	Symbol	Access	Value	Description
6 to 0	INIT_VALUE_S7_S1_LN2[6:0]	R/W	00h	initialization value for lane 2 descrambler bits s7 : s1

Table 101. INIT_SCR_S15T8_LN3 register (address 17h) bit description

Bit	Symbol	Access	Value	Description
7 to 0	INIT_VALUE_S15_S8_LN3[7:0]	R/W	00h	initialization value for lane 3 descrambler bits s15 : s8

Table 102. INIT_SCR_S7T1_LN3 register (address 18h) bit description

Bit	Symbol	Access	Value	Description
6 to 0	INIT_VALUE_S7_S1_LN3[6:0]	R/W	00h	initialization value for lane 3 descrambler bits s7 : s1

Table 103. INIT_ILA_BUFPTR_LN01 register (address 19h) bit description

Bit	Symbol	Access	Value	Description
7 to 4	INIT_ILA_BUFPTR_LN1[3:0]	R/W	8h	initialization value for lane 1 ILA buffer pointer
3 to 0	INIT_ILA_BUFPTR_LN0[3:0]	R/W	8h	initialization value for lane 0 ILA buffer pointer

Table 104. INIT_ILA_BUFPTR_LN23 register (address 1Ah) bit description

Bit	Symbol	Access	Value	Description
7 to 4	INIT_ILA_BUFPTR_LN3[3:0]	R/W	8h	initialization value for lane 3 ILA buffer pointer
3 to 0	INIT_ILA_BUFPTR_LN2[3:0]	R/W	8h	initialization value for lane 2 ILA buffer pointer

Table 105. ERROR_HANDLING register (address 1Bh) bit description

Default settings are shown highlighted.

Bit	Symbol	Access	Value	Description
6	NAD_ERR_CORR	R/W		frame assembler (fa)
			0	not-in-table errors passed to fa
			1	nad (nit and disparity) errors passed to fa
5	KUX_CORR	R/W		K-character error mode
			0	unexpected K-character errors ignored (at fa)
			1	unexpected K-character errors concealment (at fa)
4	NAD_CORR	R/W		nad error mode
			0	nad-errors ignored (at fa)
			1	nad-errors concealment (at fa)
3 to 2	CORR_MODE[1:0]	R/W		conceal mode
			00	conceal 1 period at fa
			01	conceal 2 periods at fa
			10	conceal 3 periods at fa
			11	conceal 4 periods at fa
1	IMPL_ALT	R/W		disparity error detection configuration
			0	default disparity error detection (table mode)
			1	alternative disparity error detection (cnt mode)
0	IGNORE_ERR	R/W		general error mode
			0	no action
			1	ignore disparity/nit-errors at lane-controller

Table 106. REINIT_CNTRL register (address 1Ch) bit description

Default settings are shown highlighted.

Bit	Symbol	Access	Value	Description
7	REINIT_ILA_LN3	R/W		lane 3, ila-buffer out-of-range check
			0	no action
			1	lane 3 ila-buffer out-of-range_error will activate reinitialization
6	REINIT_ILA_LN2	R/W		lane 2, ila-buffer out-of-range check
			0	no action
			1	lane 2 ila-buffer out-of-range_error will activate reinitialization
5	REINIT_ILA_LN1	R/W		lane 1, ila-buffer out-of-range check
			0	no action
			1	lane 1 ila-buffer out-of-range_error will activate reinitialization
4	REINIT_ILA_LN0	R/W		lane 0, ila-buffer out-of-range check
			0	no action
			1	lane 0 ila-buffer out-of-range_error will activate reinitialization

Table 106. REINIT_CNTRL register (address 1Ch) bit description ...continued*Default settings are shown highlighted.*

Bit	Symbol	Access	Value	Description
3	RESYNC_O_L_LN3	R/W		lane 3, resync over link
			0	no action
			1	lane 3 lane controller checks for K28.5 /K/ symbols
			0	no action
2	RESYNC_O_L_LN2	R/W		lane 2, resync over link
			0	no action
			1	lane 2 lane controller checks for K28.5 /K/ symbols
			0	no action
1	RESYNC_O_L_LN1	R/W		lane 1, resync over link
			0	no action
			1	lane 1 lane controller checks for K28.5 /K/ symbols
			0	no action
0	RESYNC_O_L_LN0	R/W		lane 0, resync over link
			0	no action
			1	lane 0 controller checks for K28.5 /K/ symbols

Table 107. PAGE_ADDRESS register (address 1Fh) bit description

Bit	Symbol	Access	Value	Description
2 to 0	PAGE[2:0]	R/W	0h	page_address

10.15.2.9 Page 5 allocation map description

Table 108. Page 5 register allocation map

Address	Register name	R/W	Bit definition								Default ^[1]		
			b7	b6	b5	b4	b3	b2	b1	b0	Bin	Hex	
0	00h	ILA_MON_1_0	R	ILA_MON_LN1[3:0]				ILA_MON_LN0[3:0]				uuuuuuuu	uuh
1	01h	ILA_MON_3_2	R	ILA_MON_LN3[3:0]				ILA_MON_LN2[3:0]				uuuuuuuu	uuh
2	02h	ILA_BUF_ERR	R	-	-	-	-	ILA_BUF_ERR_LN3	ILA_BUF_ERR_LN2	ILA_BUF_ERR_LN1	ILA_BUF_ERR_LN0	uuuuuuuu	uuh
3	03h	CA_MON	R	CA_MON_LN3[1:0]		CA_MON_LN2[1:0]		CA_MON_LN1[1:0]		CA_MON_LN0[1:0]		uuuuuuuu	uuh
4	04h	DEC_FLAGS	R	DEC_NIT_ERR_LN3	DEC_NIT_ERR_LN2	DEC_NIT_ERR_LN1	DEC_NIT_ERR_LN0	DEC_DISP_ERR_LN3	DEC_DISP_ERR_LN2	DEC_DISP_ERR_LN1	DEC_DISP_ERR_LN0	uuuuuuuu	uuh
5	05h	KOUT_FLAG	R	-	-	-	-	DEC_KOUT_LN3	DEC_KOUT_LN2	DEC_KOUT_LN1	DEC_KOUT_LN0	uuuuuuuu	uuh
6	06h	K28_LN0_FLAG	R	-	-	-	K28_7_LN0	K28_5_LN0	K28_4_LN0	K28_3_LN0	K28_0_LN0	uuuuuuuu	uuh
7	07h	K28_LN1_FLAG	R	-	-	-	K28_7_LN1	K28_5_LN1	K28_4_LN1	K28_3_LN1	K28_0_LN1	uuuuuuuu	uuh
8	08h	K28_LN2_FLAG	R	-	-	-	K28_7_LN2	K28_5_LN2	K28_4_LN2	K28_3_LN2	K28_0_LN2	uuuuuuuu	uuh
9	09h	K28_LN3_FLAG	R	-	-	-	K28_7_LN3	K28_5_LN3	K28_4_LN3	K28_3_LN3	K28_0_LN3	uuuuuuuu	uuh
10	0Ah	KOUT_UNEXPECTED_FLAG	R	-	-	-	-	DEC_KOUT_UNEXP_LN3	DEC_KOUT_UNEXP_LN2	DEC_KOUT_UNEXP_LN1	DEC_KOUT_UNEXP_LN0	uuuuuuuu	uuh
11	0Bh	LOCK_CNT_MON_LN01	R	LOCK_CNT_MON_LN1[3:0]				LOCK_CNT_MON_LN0[3:0]				uuuuuuuu	uuh
12	0Ch	LOCK_CNT_MON_LN23	R	LOCK_CNT_MON_LN3[3:0]				LOCK_CNT_MON_LN2[3:0]				uuuuuuuu	uuh
13	0Dh	CS_STATE_LNX	R	CS_STATE_LN3[1:0]		CS_STATE_LN2[1:0]		CS_STATE_LN1[1:0]		CS_STATE_LN0[1:0]		uuuuuuuu	uuh
14	0Eh	RST_BUF_ERR_FLAGS	R/W	RST_BUF_ERR_FLAGS	-	-	-	-	-	-	-	00000000	00h
15	0Fh	INTR_MISC_ENA	R/W	INTR_ENA_CS_INIT_LN3	INTR_ENA_CS_INIT_LN2	INTR_ENA_CS_INIT_LN1	INTR_ENA_CS_INIT_LN0	INTR_ENA_BUF_ERR_LN3	INTR_ENA_BUF_ERR_LN2	INTR_ENA_BUF_ERR_LN1	INTR_ENA_BUF_ERR_LN0	00000000	00h
16	10h	FLAG_CNT_LSB_LN0	R	FLAG_CNT_LN0[7:0]								uuuuuuuu	uuh

Table 108. Page 5 register allocation map ...continued

Address		Register name	R/W	Bit definition								Default ^[1]	
				b7	b6	b5	b4	b3	b2	b1	b0	Bin	Hex
17	11h	FLAG_CNT_MSB_LN0	R	FLAG_CNT_LN0[15:8]								uuuuuuuu	uuh
18	12h	FLAG_CNT_LSB_LN1	R	FLAG_CNT_LN1[7:0]								uuuuuuuu	uuh
19	13h	FLAG_CNT_MSB_LN1	R	FLAG_CNT_LN1[15:8]								uuuuuuuu	uuh
20	14h	FLAG_CNT_LSB_LN2	R	FLAG_CNT_LN2[7:0]								uuuuuuuu	uuh
21	15h	FLAG_CNT_MSB_LN2	R	FLAG_CNT_LN2[15:8]								uuuuuuuu	uuh
22	16h	FLAG_CNT_LSB_LN3	R	FLAG_CNT_LN3[7:0]								uuuuuuuu	uuh
23	17h	FLAG_CNT_MSB_LN3	R	FLAG_CNT_LN3[15:8]								uuuuuuuu	uuh
24	18h	BER_LEVEL_LSB	R/W	BER_LEVEL[7:0]								00000000	00h
25	19h	BER_LEVEL_MSB	R/W	BER_LEVEL[15:8]								00000000	00h
26	1Ah	INTR_ENA	R/W	INTR_ENA_NIT	INTR_ENA_DISP	INTR_ENA_KOUT	INTR_ENA_KOUT_UNEXP	INTR_ENA_K28_7	INTR_ENA_K28_5	INTR_ENA_K28_3	INTR_ENA_MISC	00000000	00h
27	1Bh	CNTRL_FLAGCNT_LN01	R/W	RST_CFC_LN1	SEL_CFC_LN1[2:0]			RST_CFC_LN0	SEL_CFC_LN0[2:0]			01010101	55h
28	1Ch	CNTRL_FLAGCNT_LN23	R/W	RST_CFC_LN3	SEL_CFC_LN3[2:0]			RST_CFC_LN2	SEL_CFC_LN2[2:0]			01010101	55h
29	1Dh	MON_FLAGS_RESET	R/W	RST_NIT_ERR_FLAGS	RST_DISP_ERR_FLAGS	RST_KOUT_FLAGS	RST_KOUT_UNEXPECTED_FLAGS	RST_K28_LN3_FLAGS	RST_K28_LN2_FLAGS	RST_K28_LN1_FLAGS	RST_K28_LN0_FLAGS	00000000	00h
30	1Eh	DBG_CNTRL	R/W	BER_MODE	INTR_CLEAR	INTR_MODE[2:0]			-	-	-	00000000	00h
31	1Fh	PAGE_ADDRESS	R/W	-	-	-	-	-	PAGE[2:0]			00000000	00h

[1] u = undefined at power-up or after reset.

10.15.2.10 Page 5 bit definition detailed description

Please refer to [Table 108](#) for a register overview and their default values. In the following tables, all the values emphasized in bold are the default values.

Table 109. ILA_MON_1_0 register (address 00h) bit description

Default settings are shown highlighted.

Bit	Symbol	Access	Value	Description
7 to 4	ILA_MON_LN1[3:0]	R	-	ila_buf_ln1 pointer
3 to 0	ILA_MON_LN0[3:0]	R	-	ila_buf_ln0 pointer

Table 110. ILA_MON_3_2 register (address 01h) bit description

Default settings are shown highlighted.

Bit	Symbol	Access	Value	Description
7 to 4	ILA_MON_LN3[3:0]	R	-	ila_buf_ln3 pointer
3 to 0	ILA_MON_LN2[3:0]	R	-	ila_buf_ln2 pointer

Table 111. ILA_BUF_ERR register (address 02h) bit description

Default settings are shown highlighted.

Bit	Symbol	Access	Value	Description
3	ILA_BUF_ERR_LN3	R		lane 3 ila buffer error
			0	ila_buf_ln3 pointer is in range
			1	ila_buf_ln3 pointer is out of range
2	ILA_BUF_ERR_LN2	R		lane 2 ila buffer error
			0	ila_buf_ln2 pointer is in range
			1	ila_buf_ln2 pointer is out of range
1	ILA_BUF_ERR_LN1	R		lane 1 ila buffer error
			0	ila_buf_ln1 pointer is in range
			1	ila_buf_ln1 pointer is out of range
0	ILA_BUF_ERR_LN0	R		lane 0 ila buffer error
			0	ila_buf_ln0 pointer is in range
			1	ila_buf_ln0 pointer is out of range

Table 112. CA_MON register (address 03h) bit description

Default settings are shown highlighted.

Bit	Symbol	Access	Value	Description
7 to 6	CA_MON_LN3[1:0]	R	-	clock alignment phase monitor lane 3
5 to 4	CA_MON_LN2[1:0]	R	-	clock alignment phase monitor lane 2
3 to 2	CA_MON_LN1[1:0]	R	-	clock alignment phase monitor lane 1
1 to 0	CA_MON_LN0[1:0]	R	-	clock alignment phase monitor lane 0

Table 113. DEC_FLAGS register (address 04h) bit description

Bit	Symbol	Access	Value	Description
7	DEC_NIT_ERR_LN3	R	-	not-in-table error flag lane 3
6	DEC_NIT_ERR_LN2	R	-	not-in-table error flag lane 2
5	DEC_NIT_ERR_LN1	R	-	not-in-table error flag lane 1
4	DEC_NIT_ERR_LN0	R	-	not-in-table error flag lane 0
3	DEC_DISP_ERR_LN3	R	-	disparity error flag lane 3
2	DEC_DISP_ERR_LN2	R	-	disparity error flag lane 2
1	DEC_DISP_ERR_LN1	R	-	disparity error flag lane 1
0	DEC_DISP_ERR_LN0	R	-	disparity error flag lane 0

Table 114. KOUT_FLAG register (address 05h) bit description

Bit	Symbol	Access	Value	Description
3	DEC_KOUT_LN3	R	-	/K/ symbols found in lane 3
2	DEC_KOUT_LN2	R	-	/K/ symbols found in lane 2
1	DEC_KOUT_LN1	R	-	/K/ symbols found in lane 1
0	DEC_KOUT_LN0	R	-	/K/ symbols found in lane 0

Table 115. K28_LN0_FLAG register (address 06h) bit description

Bit	Symbol	Access	Value	Description
4	K28_7_LN0	R	-	K28_7 /F/ symbols found in lane 0
3	K28_5_LN0	R	-	K28_5 /K/ symbols found in lane 0
2	K28_4_LN0	R	-	K28_4 /Q/ symbols found in lane 0
1	K28_3_LN0	R	-	K28_3 /A/ symbols found in lane 0
0	K28_0_LN0	R	-	K28_0 /R/ symbols found in lane 0

Table 116. K28_LN1_FLAG register (address 07h) bit description

Bit	Symbol	Access	Value	Description
4	K28_7_LN1	R	-	K28_7 /F/ symbols found in lane 1
3	K28_5_LN1	R	-	K28_5 /K/ symbols found in lane 1
2	K28_4_LN1	R	-	K28_4 /Q/ symbols found in lane 1
1	K28_3_LN1	R	-	K28_3 /A/ symbols found in lane 1
0	K28_0_LN1	R	-	K28_0 /R/ symbols found in lane 1

Table 117. K28_LN2_FLAG register (address 08h) bit description

Bit	Symbol	Access	Value	Description
4	K28_7_LN2	R	-	K28_7 /F/ symbols found in lane 2
3	K28_5_LN2	R	-	K28_5 /K/ symbols found in lane 2
2	K28_4_LN2	R	-	K28_4 /Q/ symbols found in lane 2
1	K28_3_LN2	R	-	K28_3 /A/ symbols found in lane 2
0	K28_0_LN2	R	-	K28_0 /R/ symbols found in lane 2

Table 118. K28_LN3_FLAG register (address 09h) bit description

Bit	Symbol	Access	Value	Description
4	K28_7_LN3	R	-	K28_7 /F/ symbols found in lane 3
3	K28_5_LN3	R	-	K28_5 /K/ symbols found in lane 3
2	K28_4_LN3	R	-	K28_4 /Q/ symbols found in lane 3
1	K28_3_LN3	R	-	K28_3 /A/ symbols found in lane 3
0	K28_0_LN3	R	-	K28_0 /R/ symbols found in lane 3

Table 119. KOUT_UNEXPECTED_FLAG register (address 0Ah) bit description

Bit	Symbol	Access	Value	Description
3	DEC_KOUT_UNEXP_LN3	R	-	unexpected /K/ symbols found in lane 3
2	DEC_KOUT_UNEXP_LN2	R	-	unexpected /K/ symbols found in lane 2
1	DEC_KOUT_UNEXP_LN1	R	-	unexpected /K/ symbols found in lane 1
0	DEC_KOUT_UNEXP_LN0	R	-	unexpected /K/ symbols found in lane 0

Table 120. LOCK_CNT_MON_LN01 register (address 0Bh) bit description

Default settings are shown highlighted.

Bit	Symbol	Access	Value	Description
7 to 4	LOCK_CNT_MON_LN1[3:0]	R	-	lock_state monitor synchronization word alignment lane 1
3 to 0	LOCK_CNT_MON_LN0[3:0]	R	-	lock_state monitor synchronization word alignment lane 0

Table 121. LOCK_CNT_MON_LN23 register (address 0Ch) bit description

Default settings are shown highlighted.

Bit	Symbol	Access	Value	Description
7 to 4	LOCK_CNT_MON_LN3[3:0]	R	-	lock_state monitor synchronization word alignment lane 3
3 to 0	LOCK_CNT_MON_LN2[3:0]	R	-	lock_state monitor synchronization word alignment lane 2

Table 122. CS_STATE_LNX register (address 0Dh) bit description

Default settings are shown highlighted.

Bit	Symbol	Access	Value	Description
7 to 6	CS_STATE_LN3[1:0]	R	-	monitor cs_state fsm lane 3 (see Table 142)
5 to 4	CS_STATE_LN2[1:0]	R	-	monitor cs_state fsm lane 2 (see Table 142)
3 to 2	CS_STATE_LN1[1:0]	R	-	monitor cs_state fsm lane 1 (see Table 142)
1 to 0	CS_STATE_LN0[1:0]	R	-	monitor cs_state fsm lane 0 (see Table 142)

Table 123. RST_BUF_ERR_FLAGS register (address 0Eh) bit description

Default settings are shown highlighted.

Bit	Symbol	Access	Value	Description
7	RST_BUF_ERR_FLAGS	R/W	0	reset ILA_BUF_ERR_LNn flags

Table 124. INTR_MISC_ENA register (address 0Fh) bit description

Default settings are shown highlighted.

Bit	Symbol	Access	Value	Description
7	INTR_ENA_CS_INIT_LN3	R/W	0	intr_misc in case cs_state_ln3 = cs_init
6	INTR_ENA_CS_INIT_LN2	R/W	0	intr_misc in case cs_state_ln2 = cs_init
5	INTR_ENA_CS_INIT_LN1	R/W	0	intr_misc in case cs_state_ln1 = cs_init
4	INTR_ENA_CS_INIT_LN0	R/W	0	intr_misc in case cs_state_ln0 = cs_init
3	INTR_ENA_BUF_ERR_LN3	R/W	0	generate interrupt if ILA_BUF_ERR_LN3 = 1
2	INTR_ENA_BUF_ERR_LN2	R/W	0	generate interrupt if ILA_BUF_ERR_LN2 = 1
1	INTR_ENA_BUF_ERR_LN1	R/W	0	generate interrupt if ILA_BUF_ERR_LN1 = 1
0	INTR_ENA_BUF_ERR_LN0	R/W	0	generate interrupt if ILA_BUF_ERR_LN0 = 1

Table 125. FLAG_CNT_LSB_LN0 register (address 10h) bit description

Default settings are shown highlighted.

Bit	Symbol	Access	Value	Description
7 to 0	FLAG_CNT_LN0[7:0]	R	-	LSBs of flag_counter lane 0

Table 126. FLAG_CNT_MSB_LN0 register (address 11h) bit description

Default settings are shown highlighted.

Bit	Symbol	Access	Value	Description
7 to 0	FLAG_CNT_LN0[15:8]	R	-	MSBs of flag_counter lane 0

Table 127. FLAG_CNT_LSB_LN1 register (address 12h) bit description

Default settings are shown highlighted.

Bit	Symbol	Access	Value	Description
7 to 0	FLAG_CNT_LN1[7:0]	R	-	LSBs of flag_counter lane 1

Table 128. FLAG_CNT_MSB_LN1 register (address 13h) bit description

Default settings are shown highlighted.

Bit	Symbol	Access	Value	Description
7 to 0	FLAG_CNT_LN1[15:8]	R	-	MSBs of flag_counter lane 1

Table 129. FLAG_CNT_LSB_LN2 register (address 14h) bit description

Default settings are shown highlighted.

Bit	Symbol	Access	Value	Description
7 to 0	FLAG_CNT_LN2[7:0]	R	-	LSBs of flag_counter lane 2

Table 130. FLAG_CNT_MSB_LN2 register (address 15h) bit description

Default settings are shown highlighted.

Bit	Symbol	Access	Value	Description
7 to 0	FLAG_CNT_LN2[15:8]	R	-	MSBs of flag_counter lane 2

Table 131. FLAG_CNT_LSB_LN3 register (address 16h) bit description

Default settings are shown highlighted.

Bit	Symbol	Access	Value	Description
7 to 0	FLAG_CNT_LN3[7:0]	R	-	LSBs of flag_counter lane 3

Table 132. FLAG_CNT_MSB_LN3 register (address 17h) bit description

Default settings are shown highlighted.

Bit	Symbol	Access	Value	Description
7 to 0	FLAG_CNT_LN3[15:8]	R	-	MSBs of flag_counter lane 3

Table 133. BER_LEVEL_LSB register (address 18h) bit description

Default settings are shown highlighted.

Bit	Symbol	Access	Value	Description
7 to 0	BER_LEVEL[7:0]	R/W	00h	LSBs level used for simple (DC) BER-measurement

Table 134. BER_LEVEL_MSB register (address 19h) bit description

Default settings are shown highlighted.

Bit	Symbol	Access	Value	Description
7 to 0	BER_LEVEL[15:8]	R/W	00h	MSBs level used for simple (DC) BER-measurement

Table 135. INTR_ENA register (address 1Ah) bit description

Bit	Symbol	Access	Value	Description
7	INTR_ENA_NIT	R/W		not-in-table interrupt
			0	no action
			1	nit-error in ln<x> affects i_ln<x>
6	INTR_ENA_DISP	R/W		disparity-error interrupt
			0	no action
			1	disparity-error in ln<x> affects i_ln<x>
5	INTR_ENA_KOUT	R/W		K-character interrupt
			0	no action
			1	detection K-control character in ln<x> affects i_ln<x>
4	INTR_ENA_KOUT_UNEXP	R/W		unexpected K-character interrupt
			0	no action
			1	detection unexpected K-character in ln<x> affects i_ln<x>
3	INTR_ENA_K28_7	R/W		K28_7 interrupt
			0	no action
			1	detection K28_7 in ln<x> affects i_ln<x>
2	INTR_ENA_K28_5	R/W		K28_5 interrupt
			0	no action
			1	detection K28_5 in ln<x> affects i_ln<x>
1	INTR_ENA_K28_3	R/W		K28_3 interrupt
			0	no action
			1	detection K28_3 in ln<x> affects i_ln<x>
0	INTR_ENA_MISC	R/W		miscellaneous interrupt
			0	no action
			1	detection depends on intr_misc_ena (see Table 124)

Table 136. CNTRL_FLAGCNT_LN01 register (address 1Bh) bit description

Default settings are shown highlighted.

Bit	Symbol	Access	Value	Description
7	RST_CFC_LN1	R/W	0	reset FLAG_CNT_LN1
6 to 4	SEL_CFC_LN1[2:0]	R/W	5h	select FLAG_CNT_LN1 source (see Table 141)
3	RST_CFC_LN0	R/W	0	reset FLAG_CNT_LN0
2 to 0	SEL_CFC_LN0[2:0]	R/W	5h	select FLAG_CNT_LN0 source (see Table 141)

Table 137. CNTRL_FLAGCNT_LN23 register (address 1Ch) bit description

Default settings are shown highlighted.

Bit	Symbol	Access	Value	Description
7	RST_CFC_LN3	R/W	0	reset FLAG_CNT_LN3
6 to 4	SEL_CFC_LN3[2:0]	R/W	5h	select FLAG_CNT_LN3 source (see Table 141)
3	RST_CFC_LN2	R/W	0	reset FLAG_CNT_LN2
2 to 0	SEL_CFC_LN2[2:0]	R/W	5h	select FLAG_CNT_LN2 source (see Table 141)

Table 138. MON_FLAGS_RESET register (address 1Dh) bit description

Bit	Symbol	Access	Value	Description
7	RST_NIT_ERR_FLAGS	R/W	0	reset nit-error monitor flags
6	RST_DISP_ERR_FLAGS	R/W	0	reset disparity monitor flags
5	RST_KOUT_FLAGS	R/W	0	reset K symbols monitor flags
4	RST_KOUT_UNEXPECTED_FLAGS	R/W	0	reset unexpected K symbols monitor flags
3	RST_K28_LN3_FLAGS	R/W	0	reset K28_x monitor flags for lane 3
2	RST_K28_LN2_FLAGS	R/W	0	reset K28_x monitor flags for lane 2
1	RST_K28_LN1_FLAGS	R/W	0	reset K28_x monitor flags for lane 1
0	RST_K28_LN0_FLAGS	R/W	0	reset K28_x monitor flags for lane 0

Table 139. DBG_CNTRL register (address 1Eh) bit description

Bit	Symbol	Access	Value	Description
7	BER_MODE	R/W		simple BER-measurement
			0	no action
			1	simple BER-measurement enabled
6	INTR_CLEAR	R/W		interrupts clear
			0	no action
			1	clear interrupts (to '1')
5 to 3	INTR_MODE[2:0]	R/W		interrupt settings
			000	global interrupt depends on lane 0
			001	global interrupt depends on lane 1
			010	global interrupt depends on lane 2
			011	global interrupt depends on lane 3
			100	global interrupt depends on lane 0 or lane 1
			101	global interrupt depends on lane 2 or lane 3
			110	global interrupt depends on lane 0 or lane 1 or lane 2 or lane 3
			111	no interrupt

Table 140. PAGE_ADDRESS register (address 1Fh) bit description

Bit	Symbol	Access	Value	Description
2 to 0	PAGE[2:0]	R/W	0h	page_address

Table 141. Counter source

Default settings are shown highlighted.

SEL_CFC_LNn[2:0]	Source
000	not-in-table error
001	disparity error
010	K symbol found
011	unexpected K symbol found
100	K28_7 (/F) symbol found
101	K28_5 (/K) symbol found
110	K28_3 (/A) symbol found
111	K28_0 (/R) symbol found

Table 142. Code group synchronization state machine

CS_STATE_LNn[1:0]	Definition
00	looking for K28_5 (/K) symbol
01	four consecutive K28_5 (/K) symbols have been received
10	code group synchronization achieved
11	not applicable

10.15.2.11 Page 6 allocation map description

Table 143. Page 6 register allocation map

Address	Register name	R/W	Bit definition								Default ^[1]		
			b7	b6	b5	b4	b3	b2	b1	b0	Bin	Hex	
0	00h	LN0_CFG_0	R	LN0_DID[7:0]								uuuuuuuu	0xuu
1	01h	LN0_CFG_1	R	-	-	-	-	LN0_BID[3:0]				uuuuuuuu	0xuu
2	02h	LN0_CFG_2	R	-	-	-	LN0_LID[4:0]				uuuuuuuu	0xuu	
3	03h	LN0_CFG_3	R	LN0_SCR	-	-	LN0_L[4:0]				uuuuuuuu	0xuu	
4	04h	LN0_CFG_4	R	LN0_F[7:0]								uuuuuuuu	0xuu
5	05h	LN0_CFG_5	R	-	-	-	LN0_K[4:0]				uuuuuuuu	0xuu	
6	06h	LN0_CFG_6	R	LN0_M[7:0]								uuuuuuuu	0xuu
7	07h	LN0_CFG_7	R	LN0_CS[1:0]		-	LN0_N[4:0]				uuuuuuuu	0xuu	
8	08h	LN0_CFG_8	R	-	-	-	LN0_N'[4:0]				uuuuuuuu	0xuu	
9	09h	LN0_CFG_9	R	-	-	-	LN0_S[4:0]				uuuuuuuu	0xuu	
10	0Ah	LN0_CFG_10	R	LN0_HD	-	-	LN0_CF[4:0]				uuuuuuuu	0xuu	
11	0Bh	LN0_CFG_11	R	LN0_RES1[7:0]								uuuuuuuu	0xuu
12	0Ch	LN0_CFG_12	R	LN0_RES2[7:0]								uuuuuuuu	0xuu
13	0Dh	LN0_CFG_13	R	LN0_FCHK[7:0]								uuuuuuuu	0xuu
16	10h	LN1_CFG_0	R	LN1_DID[7:0]								uuuuuuuu	0xuu
17	11h	LN1_CFG_1	R	-	-	-	-	LN1_BID[3:0]				uuuuuuuu	0xuu
18	12h	LN1_CFG_2	R	-	-	-	LN1_LID[4:0]				uuuuuuuu	0xuu	
19	13h	LN1_CFG_3	R	LN1_SCR	-	-	LN1_L[4:0]				uuuuuuuu	0xuu	
20	14h	LN1_CFG_4	R	LN1_F[7:0]								uuuuuuuu	0xuu
21	15h	LN1_CFG_5	R	-	-	-	LN1_K[4:0]				uuuuuuuu	0xuu	
22	16h	LN1_CFG_6	R	LN1_M[7:0]								uuuuuuuu	0xuu
23	17h	LN1_CFG_7	R	LN1_CS[1:0]		-	LN1_N[4:0]				uuuuuuuu	0xuu	
24	18h	LN1_CFG_8	R	-	-	-	LN1_N'[4:0]				uuuuuuuu	0xuu	
25	19h	LN1_CFG_9	R	-	-	-	LN1_S[4:0]				uuuuuuuu	0xuu	
26	1Ah	LN1_CFG_10	R	LN1_HD	-	-	LN1_CF[4:0]				uuuuuuuu	0xuu	
27	1Bh	LN1_CFG_11	R	LN1_RES1[7:0]								uuuuuuuu	0xuu

Table 143. Page 6 register allocation map ...continued

Address	Register name	R/W	Bit definition								Default ^[1]		
			b7	b6	b5	b4	b3	b2	b1	b0	Bin	Hex	
28	1Ch	LN1_CFG_12	R	LN1_RES2[7:0]								uuuuuuuu	0xuu
29	1Dh	LN1_CFG_13	R	LN1_FCHK[7:0]								uuuuuuuu	0xuu
31	1Fh	PAGE_ADDRESS	R/W	-	-	-	-	-	PAGE[2:0]		00000000	00h	

[1] u = undefined at power-up or after reset.

10.15.2.12 Page 6 bit definition detailed description

Please refer to [Table 143](#) for a register overview and their default values. In the following tables, all the values emphasized in bold are the default values.

Table 144. LN0_CFG_0 register (address 00h) bit description

Default settings are shown highlighted.

Bit	Symbol	Access	Value	Description
7 to 0	LN0_DID[7:0]	R	-	lane 0 device ID

Table 145. LN0_CFG_1 register (address 01h) bit description

Default settings are shown highlighted.

Bit	Symbol	Access	Value	Description
3 to 0	LN0_BID[3:0]	R	-	lane 0 bank ID

Table 146. LN0_CFG_2 register (address 02h) bit description

Default settings are shown highlighted.

Bit	Symbol	Access	Value	Description
4 to 0	LN0_LID[4:0]	R	-	lane 0 lane ID

Table 147. LN0_CFG_3 register (address 03h) bit description

Default settings are shown highlighted.

Bit	Symbol	Access	Value	Description
7	LN0_SCR	R	-	scrambling on
4 to 0	LN0_L[4:0]	R	-	number of lanes minus 1

Table 148. LN0_CFG_4 register (address 04h) bit description

Default settings are shown highlighted.

Bit	Symbol	Access	Value	Description
7 to 0	LN0_F[7:0]	R	-	number of octets per frame minus 1

Table 149. LN0_CFG_5 register (address 05h) bit description

Default settings are shown highlighted.

Bit	Symbol	Access	Value	Description
4 to 0	LN0_K[4:0]	R	-	number of frames per multi-frame minus 1

Table 150. LN0_CFG_6 register (address 06h) bit description

Default settings are shown highlighted.

Bit	Symbol	Access	Value	Description
7 to 0	LN0_M[7:0]	R	-	number of converters per device minus 1

Table 151. LN0_CFG_7 register (address 07h) bit description

Default settings are shown highlighted.

Bit	Symbol	Access	Value	Description
7 to 6	LN0_CS[1:0]	R	-	number of control bits
4 to 0	LN0_N[4:0]	R	-	converter resolution minus 1

Table 152. LN0_CFG_8 register (address 08h) bit description

Default settings are shown highlighted.

Bit	Symbol	Access	Value	Description
4 to 0	LN0_N'[4:0]	R	-	number of bits per sample minus 1

Table 153. LN0_CFG_9 register (address 09h) bit description

Default settings are shown highlighted.

Bit	Symbol	Access	Value	Description
4 to 0	LN0_S[4:0]	R	-	number of samples per converter per frame cycle minus 1

Table 154. LN0_CFG_10 register (address 0Ah) bit description

Default settings are shown highlighted.

Bit	Symbol	Access	Value	Description
7	LN0_HD	R	-	high density
4 to 0	LN0_CF[4:0]	R	-	number of control words per frame cycle

Table 155. LN0_CFG_11 register (address 0Bh) bit description

Default settings are shown highlighted.

Bit	Symbol	Access	Value	Description
7 to 0	LN0_RES1[7:0]	R	-	lane 0 reserved field

Table 156. LN0_CFG_12 register (address 0Ch) bit description

Default settings are shown highlighted.

Bit	Symbol	Access	Value	Description
7 to 0	LN0_RES2[7:0]	R	-	lane 0 reserved field

Table 157. LN0_CFG_13 register (address 0Dh) bit description

Default settings are shown highlighted.

Bit	Symbol	Access	Value	Description
7 to 0	LN0_FCHK[7:0]	R	-	lane 0 checksum

Table 158. LN1_CFG_0 register (address 10h) bit description

Default settings are shown highlighted.

Bit	Symbol	Access	Value	Description
7 to 0	LN1_DID[7:0]	R	-	lane 1 device ID

Table 159. LN1_CFG_1 register (address 11h) bit description

Default settings are shown highlighted.

Bit	Symbol	Access	Value	Description
3 to 0	LN1_BID[3:0]	R	-	lane 1 bank ID

Table 160. LN1_CFG_2 register (address 12h) bit description

Default settings are shown highlighted.

Bit	Symbol	Access	Value	Description
4 to 0	LN1_LID[4:0]	R	-	lane 1 lane ID

Table 161. LN1_CFG_3 register (address 13h) bit description*Default settings are shown highlighted.*

Bit	Symbol	Access	Value	Description
7	LN1_SCR	R	-	scrambling on
4 to 0	LN1_L[4:0]	R	-	number of lanes minus 1

Table 162. LN1_CFG_4 register (address 14h) bit description*Default settings are shown highlighted.*

Bit	Symbol	Access	Value	Description
7 to 0	LN1_F[7:0]	R	-	number of octets per frame minus 1

Table 163. LN1_CFG_5 register (address 15h) bit description*Default settings are shown highlighted.*

Bit	Symbol	Access	Value	Description
4 to 0	LN1_K[4:0]	R	-	number of frames per multiframe minus 1

Table 164. LN1_CFG_6 register (address 16h) bit description*Default settings are shown highlighted.*

Bit	Symbol	Access	Value	Description
7 to 0	LN1_M[7:0]	R	-	number of converters per device minus 1

Table 165. LN1_CFG_7 register (address 17h) bit description*Default settings are shown highlighted.*

Bit	Symbol	Access	Value	Description
7 to 6	LN1_CS[1:0]	R	-	number of control bits
4 to 0	LN1_N[4:0]	R	-	converter resolution minus 1

Table 166. LN1_CFG_8 register (address 18h) bit description*Default settings are shown highlighted.*

Bit	Symbol	Access	Value	Description
4 to 0	LN1_N'[4:0]	R	-	number of bits per sample minus 1

Table 167. LN1_CFG_9 register (address 19h) bit description*Default settings are shown highlighted.*

Bit	Symbol	Access	Value	Description
4 to 0	LN1_S[4:0]	R	-	number of samples per converter per frame cycle minus 1

Table 168. LN1_CFG_10 register (address 1Ah) bit description*Default settings are shown highlighted.*

Bit	Symbol	Access	Value	Description
7 to 6	LN1_HD	R	-	high density
4 to 0	LN1_CF[4:0]	R	-	number of control words per frame cycle

Table 169. LN1_CFG_11 register (address 1Bh) bit description*Default settings are shown highlighted.*

Bit	Symbol	Access	Value	Description
7 to 0	LN1_RES1[7:0]	R	-	lane 1 reserved field

Table 170. LN1_CFG_12 register (address 1Ch) bit description*Default settings are shown highlighted.*

Bit	Symbol	Access	Value	Description
7 to 0	LN1_RES2[7:0]	R	-	lane 1 reserved field

Table 171. LN1_CFG_13 register (address 1Dh) bit description*Default settings are shown highlighted.*

Bit	Symbol	Access	Value	Description
7 to 0	LN1_FCHK[7:0]	R	-	lane 1 checksum

Table 172. PAGE_ADDRESS register (address 1Fh) bit description*Default settings are shown highlighted.*

Bit	Symbol	Access	Value	Description
2 to 0	PAGE[2:0]	R/W	0h	page_address

10.15.2.13 Page 7 allocation map description

Table 173. Page 7 register allocation map

Address	Register name	R/W	Bit definition								Default ^[1]		
			b7	b6	b5	b4	b3	b2	b1	b0	Bin	Hex	
0	00h	LN2_CFG_0	R	LN2_DID[7:0]								uuuuuuuu	0xuu
1	01h	LN2_CFG_1	R	-	-	-	-	LN2_BID[3:0]				uuuuuuuu	0xuu
2	02h	LN2_CFG_2	R	-	-	-	LN2_LID[4:0]				uuuuuuuu	0xuu	
3	03h	LN2_CFG_3	R	LN2_SCR	-	-	LN2_L[4:0]				uuuuuuuu	0xuu	
4	04h	LN2_CFG_4	R	LN2_F[7:0]								uuuuuuuu	0xuu
5	05h	LN2_CFG_5	R	-	-	-	LN2_K[4:0]				uuuuuuuu	0xuu	
6	06h	LN2_CFG_6	R	LN2_M[7:0]								uuuuuuuu	0xuu
7	07h	LN2_CFG_7	R	LN2_CS[1:0]		-	LN2_N[4:0]				uuuuuuuu	0xuu	
8	08h	LN2_CFG_8	R	-	-	-	LN2_N'[4:0]				uuuuuuuu	0xuu	
9	09h	LN2_CFG_9	R	-	-	-	LN2_S[4:0]				uuuuuuuu	0xuu	
10	0Ah	LN2_CFG_10	R	LN2_HD	-	-	LN2_CF[4:0]				uuuuuuuu	0xuu	
11	0Bh	LN2_CFG_11	R	LN2_RES1[7:0]								uuuuuuuu	0xuu
12	0Ch	LN2_CFG_12	R	LN2_RES2[7:0]								uuuuuuuu	0xuu
13	0Dh	LN2_CFG_13	R	LN2_FCHK[7:0]								uuuuuuuu	0xuu
16	10h	LN3_CFG_0	R	LN3_DID[7:0]								uuuuuuuu	0xuu
17	11h	LN3_CFG_1	R	-	-	-	-	LN3_BID[3:0]				uuuuuuuu	0xuu
18	12h	LN3_CFG_2	R	-	-	-	LN3_LID[4:0]				uuuuuuuu	0xuu	
19	13h	LN3_CFG_3	R	LN3_SCR	-	-	LN3_L[4:0]				uuuuuuuu	0xuu	
20	14h	LN3_CFG_4	R	LN3_F[7:0]								uuuuuuuu	0xuu
21	15h	LN3_CFG_5	R	-	-	-	LN3_K[4:0]				uuuuuuuu	0xuu	
22	16h	LN3_CFG_6	R	LN3_M[7:0]								uuuuuuuu	0xuu
23	17h	LN3_CFG_7	R	LN3_CS[1:0]		-	LN3_N[4:0]				uuuuuuuu	0xuu	
24	18h	LN3_CFG_8	R	-	-	-	LN3_N'[4:0]				uuuuuuuu	0xuu	
25	19h	LN3_CFG_9	R	-	-	-	LN3_S[4:0]				uuuuuuuu	0xuu	
26	1Ah	LN3_CFG_10	R	LN3_HD	-	-	LN3_CF[4:0]				uuuuuuuu	0xuu	
27	1Bh	LN3_CFG_11	R	LN3_RES1[7:0]								uuuuuuuu	0xuu

Table 173. Page 7 register allocation map ...continued

Address	Register name	R/W	Bit definition								Default ^[1]		
			b7	b6	b5	b4	b3	b2	b1	b0	Bin	Hex	
28	1Ch	LN3_CFG_12	R	LN3_RES2[7:0]								uuuuuuuu	0xuu
29	1Dh	LN3_CFG_13	R	LN3_FCHK[7:0]								uuuuuuuu	0xuu
31	1Fh	PAGE_ADDRESS	R/W	-	-	-	-	-	PAGE[2:0]		00000000	00h	

[1] u = undefined at power-up or after reset.

10.15.2.14 Page 7 bit definition detailed description

Please refer to [Table 173](#) for a register overview and their default values. In the following tables, all the values emphasized in bold are the default values.

Table 174. LN2_CFG_0 register (address 00h) bit description

Default settings are shown highlighted.

Bit	Symbol	Access	Value	Description
7 to 0	LN2_DID[7:0]	R	-	lane 2 device ID

Table 175. LN2_CFG_1 register (address 01h) bit description

Default settings are shown highlighted.

Bit	Symbol	Access	Value	Description
3 to 0	LN2_BID[3:0]	R	-	lane 2 bank ID

Table 176. LN2_CFG_2 register (address 02h) bit description

Default settings are shown highlighted.

Bit	Symbol	Access	Value	Description
4 to 0	LN2_LID[4:0]	R	-	lane 2 lane ID

Table 177. LN2_CFG_3 register (address 03h) bit description

Default settings are shown highlighted.

Bit	Symbol	Access	Value	Description
7	LN2_SCR	R	-	scrambling on
4 to 0	LN2_L[4:0]	R	-	number of lanes minus 1

Table 178. LN2_CFG_4 register (address 04h) bit description

Default settings are shown highlighted.

Bit	Symbol	Access	Value	Description
7 to 0	LN2_F[7:0]	R	-	number of octets per frame minus 1

Table 179. LN2_CFG_5 register (address 05h) bit description

Default settings are shown highlighted.

Bit	Symbol	Access	Value	Description
4 to 0	LN2_K[4:0]	R	-	number of frames per multiframe minus 1

Table 180. LN2_CFG_6 register (address 06h) bit description

Default settings are shown highlighted.

Bit	Symbol	Access	Value	Description
7 to 0	LN2_M[7:0]	R	-	number of converters per device minus 1

Table 181. LN2_CFG_7 register (address 07h) bit description

Default settings are shown highlighted.

Bit	Symbol	Access	Value	Description
7 to 6	LN2_CS[1:0]	R	-	number of control bits
4 to 0	LN2_N[4:0]	R	-	converter resolution minus 1

Table 182. LN2_CFG_8 register (address 08h) bit description

Default settings are shown highlighted.

Bit	Symbol	Access	Value	Description
4 to 0	LN2_N'[4:0]	R	-	number of bits per sample minus 1

Table 183. LN2_CFG_9 register (address 09h) bit description

Default settings are shown highlighted.

Bit	Symbol	Access	Value	Description
4 to 0	LN2_S[4:0]	R	-	number of samples per converter per frame cycle minus 1

Table 184. LN2_CFG_10 register (address 0Ah) bit description

Default settings are shown highlighted.

Bit	Symbol	Access	Value	Description
7	LN2_HD	R	-	high density
4 to 0	LN2_CF[4:0]	R	-	number of control words per frame cycle

Table 185. LN2_CFG_11 register (address 0Bh) bit description

Default settings are shown highlighted.

Bit	Symbol	Access	Value	Description
7 to 0	LN2_RES1[7:0]	R	-	lane 2 reserved field

Table 186. LN2_CFG_12 register (address 0Ch) bit description

Default settings are shown highlighted.

Bit	Symbol	Access	Value	Description
7 to 0	LN2_RES2[7:0]	R	-	lane 2 reserved field

Table 187. LN2_CFG_13 register (address 0Dh) bit description

Default settings are shown highlighted.

Bit	Symbol	Access	Value	Description
7 to 0	LN2_FCHK[7:0]	R	-	lane 2 checksum

Table 188. LN3_CFG_0 register (address 10h) bit description

Default settings are shown highlighted.

Bit	Symbol	Access	Value	Description
7 to 0	LN3_DID[7:0]	R	-	lane 3 device ID

Table 189. LN3_CFG_1 register (address 11h) bit description

Default settings are shown highlighted.

Bit	Symbol	Access	Value	Description
3 to 0	LN3_BID[3:0]	R	-	lane 3 bank ID

Table 190. LN3_CFG_2 register (address 12h) bit description

Default settings are shown highlighted.

Bit	Symbol	Access	Value	Description
4 to 0	LN3_LID[4:0]	R	-	lane 3 lane ID

Table 191. LN3_CFG_3 register (address 13h) bit description*Default settings are shown highlighted.*

Bit	Symbol	Access	Value	Description
7	LN3_SCR	R	-	scrambling on
4 to 0	LN3_L[4:0]	R	-	number of lanes minus 1

Table 192. LN3_CFG_4 register (address 14h) bit description*Default settings are shown highlighted.*

Bit	Symbol	Access	Value	Description
7 to 0	LN3_F[7:0]	R	-	number of octets per frame minus 1

Table 193. LN3_CFG_5 register (address 15h) bit description*Default settings are shown highlighted.*

Bit	Symbol	Access	Value	Description
4 to 0	LN3_K[4:0]	R	-	number of frames per multiframe minus 1

Table 194. LN3_CFG_6 register (address 16h) bit description*Default settings are shown highlighted.*

Bit	Symbol	Access	Value	Description
7 to 0	LN3_M[7:0]	R	-	number of converters per device minus 1

Table 195. LN3_CFG_7 register (address 17h) bit description*Default settings are shown highlighted.*

Bit	Symbol	Access	Value	Description
7 to 6	LN3_CS[1:0]	R	-	number of control bits
4 to 0	LN3_N[4:0]	R	-	converter resolution minus 1

Table 196. LN3_CFG_8 register (address 18h) bit description*Default settings are shown highlighted.*

Bit	Symbol	Access	Value	Description
4 to 0	LN3_N'[4:0]	R	-	number of bits per sample minus 1

Table 197. LN3_CFG_9 register (address 19h) bit description*Default settings are shown highlighted.*

Bit	Symbol	Access	Value	Description
4 to 0	LN3_S[4:0]	R	-	number of samples per converter per frame cycle minus 1

Table 198. LN3_CFG_10 register (address 1Ah) bit description*Default settings are shown highlighted.*

Bit	Symbol	Access	Value	Description
7	LN3_HD	R	-	high density
4 to 0	LN3_CF[4:0]	R	-	number of control words per frame cycle

Table 199. LN3_CFG_11 register (address 1Bh) bit description*Default settings are shown highlighted.*

Bit	Symbol	Access	Value	Description
7 to 0	LN3_RES1[7:0]	R	-	lane 3 reserved field

Table 200. LN3_CFG_12 register (address 1Ch) bit description*Default settings are shown highlighted.*

Bit	Symbol	Access	Value	Description
7 to 0	LN3_RES2[7:0]	R	-	lane 3 reserved field

Table 201. LN3_CFG_13 register (address 1Dh) bit description*Default settings are shown highlighted.*

Bit	Symbol	Access	Value	Description
7 to 0	LN3_FCHK[7:0]	R	-	lane 3 checksum

Table 202. PAGE_ADDRESS register (address 1Fh) bit description*Default settings are shown highlighted.*

Bit	Symbol	Access	Value	Description
2 to 0	PAGE[2:0]	R/W	0h	page_address

11. Package outline

HVQFN64: plastic thermal enhanced very thin quad flat package; no leads; 64 terminals; body 9 x 9 x 0.85 mm

SOT804-3

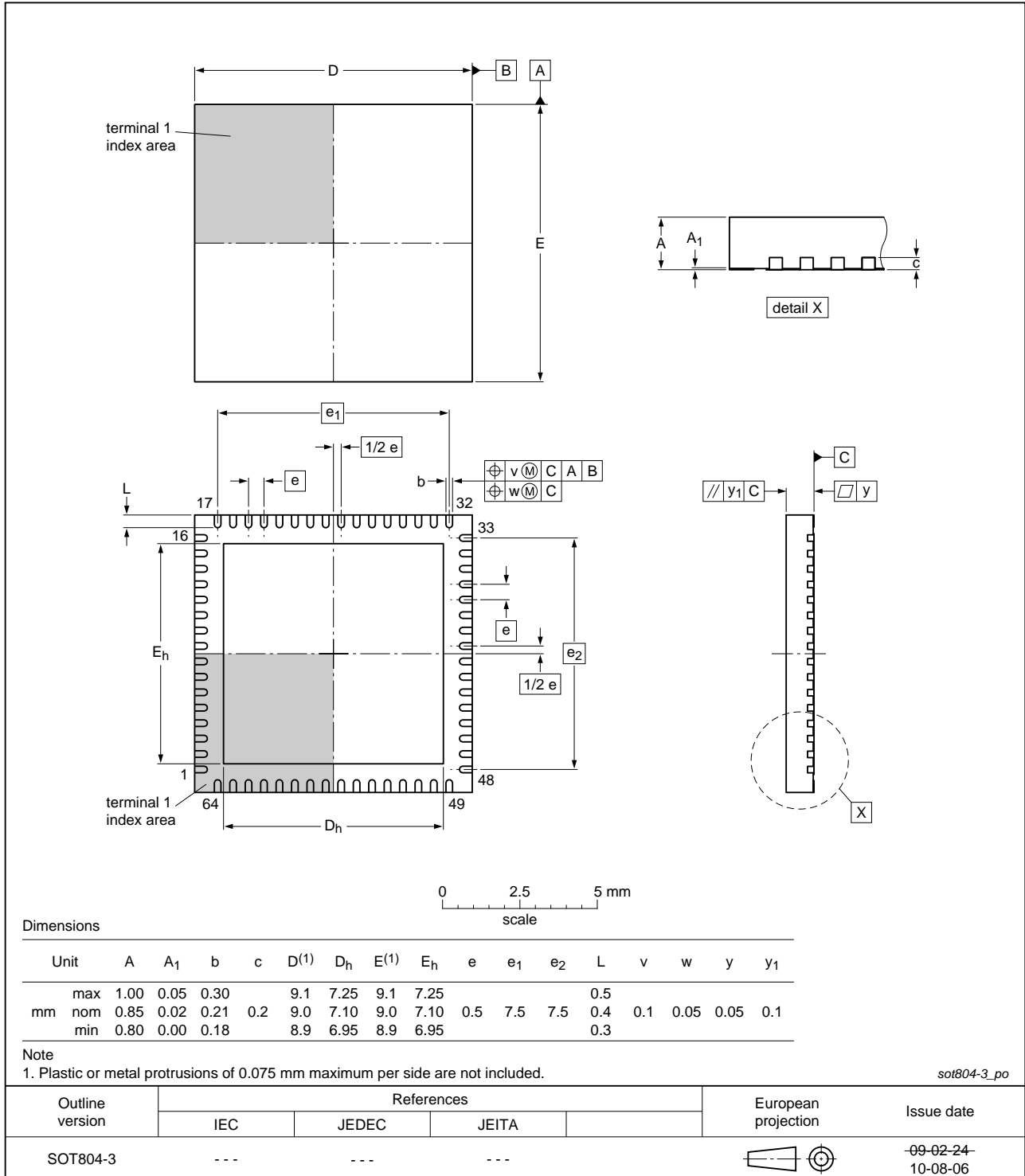

Fig 26. Package outline SOT804 (HVQFN64)

12. Abbreviations

Table 203. Abbreviations

Acronym	Description
AQM	Analog Quadrature Modulator
BER	Bit Error Rate
BW	BandWidth
CDI	Clock Domain Interface
CDMA	Code Division Multiple Access
CML	Current Mode Logic
CMOS	Complementary Metal Oxide Semiconductor
DAC	Digital-to-Analog Converter
DCSMU	Device Configuration Management and Start-up Unit
DES	DESerializer
EDGE	Enhanced Data rates for GSM Evolution
FIR	Finite Impulse Response
FPGA	Field Programmable Gate Array
GSM	Global System for Mobile communications
IF	Intermediate Frequency
ILA	Inter-Lane Alignment
IMD3	third order InterMoDulation product
LMDS	Local Multipoint Distribution Service
LSB	Least Significant Bit
LTE	Long Term Evolution
LVDS	Low-Voltage Differential Signaling
MDS	Multipoint Distribution Service
MMDS	Multichannel Multipoint Distribution Service
MSB	Most Significant Bit
NCO	Numerically Controlled Oscillator
NMOS	Negative Metal-Oxide Semiconductor
PLL	Phase-Locked Loop
SERDES	SERializer/DESerializer
SFDR	Spurious Free Dynamic Range
SPI	Serial Peripheral Interface
TD-SCDMA	Time Division-Synchronous Code Division Multiple Access
WCDMA	Wideband Code Division Multiple Access
WiMax	Worldwide interoperability for Microwave Access

13. Revision history

Table 204. Revision history

Document ID	Release date	Data sheet status	Change notice	Supersedes
DAC1008D750 v.3	20120131	Product data sheet	-	DAC1008D750 v.2
Modifications:		<ul style="list-style-type: none">• Section 2 “Features and benefits” has been updated.• The values for $V_{O(\text{ref})}$ in Table 5 “Characteristics” have been updated.• Section 10.9.1 “Regulation” has been updated.		
DAC1008D750 v.2	20110105	Product data sheet	-	DAC1008D750 v.1
DAC1008D750 v.1	20101004	Objective data sheet	-	-

14. Legal information

14.1 Data sheet status

Document status ^{[1][2]}	Product status ^[3]	Definition
Objective [short] data sheet	Development	This document contains data from the objective specification for product development.
Preliminary [short] data sheet	Qualification	This document contains data from the preliminary specification.
Product [short] data sheet	Production	This document contains the product specification.

[1] Please consult the most recently issued document before initiating or completing a design.

[2] The term 'short data sheet' is explained in section "Definitions".

[3] The product status of device(s) described in this document may have changed since this document was published and may differ in case of multiple devices. The latest product status information is available on the Internet at URL <http://www.nxp.com>.

14.2 Definitions

Draft — The document is a draft version only. The content is still under internal review and subject to formal approval, which may result in modifications or additions. NXP Semiconductors does not give any representations or warranties as to the accuracy or completeness of information included herein and shall have no liability for the consequences of use of such information.

Short data sheet — A short data sheet is an extract from a full data sheet with the same product type number(s) and title. A short data sheet is intended for quick reference only and should not be relied upon to contain detailed and full information. For detailed and full information see the relevant full data sheet, which is available on request via the local NXP Semiconductors sales office. In case of any inconsistency or conflict with the short data sheet, the full data sheet shall prevail.

Product specification — The information and data provided in a Product data sheet shall define the specification of the product as agreed between NXP Semiconductors and its customer, unless NXP Semiconductors and customer have explicitly agreed otherwise in writing. In no event however, shall an agreement be valid in which the NXP Semiconductors product is deemed to offer functions and qualities beyond those described in the Product data sheet.

14.3 Disclaimers

Limited warranty and liability — Information in this document is believed to be accurate and reliable. However, NXP Semiconductors does not give any representations or warranties, expressed or implied, as to the accuracy or completeness of such information and shall have no liability for the consequences of use of such information. NXP Semiconductors takes no responsibility for the content in this document if provided by an information source outside of NXP Semiconductors.

In no event shall NXP Semiconductors be liable for any indirect, incidental, punitive, special or consequential damages (including - without limitation - lost profits, lost savings, business interruption, costs related to the removal or replacement of any products or rework charges) whether or not such damages are based on tort (including negligence), warranty, breach of contract or any other legal theory.

Notwithstanding any damages that customer might incur for any reason whatsoever, NXP Semiconductors' aggregate and cumulative liability towards customer for the products described herein shall be limited in accordance with the *Terms and conditions of commercial sale* of NXP Semiconductors.

Right to make changes — NXP Semiconductors reserves the right to make changes to information published in this document, including without limitation specifications and product descriptions, at any time and without notice. This document supersedes and replaces all information supplied prior to the publication hereof.

Suitability for use — NXP Semiconductors products are not designed, authorized or warranted to be suitable for use in life support, life-critical or safety-critical systems or equipment, nor in applications where failure or malfunction of an NXP Semiconductors product can reasonably be expected to result in personal injury, death or severe property or environmental damage. NXP Semiconductors and its suppliers accept no liability for inclusion and/or use of NXP Semiconductors products in such equipment or applications and therefore such inclusion and/or use is at the customer's own risk.

Applications — Applications that are described herein for any of these products are for illustrative purposes only. NXP Semiconductors makes no representation or warranty that such applications will be suitable for the specified use without further testing or modification.

Customers are responsible for the design and operation of their applications and products using NXP Semiconductors products, and NXP Semiconductors accepts no liability for any assistance with applications or customer product design. It is customer's sole responsibility to determine whether the NXP Semiconductors product is suitable and fit for the customer's applications and products planned, as well as for the planned application and use of customer's third party customer(s). Customers should provide appropriate design and operating safeguards to minimize the risks associated with their applications and products.

NXP Semiconductors does not accept any liability related to any default, damage, costs or problem which is based on any weakness or default in the customer's applications or products, or the application or use by customer's third party customer(s). Customer is responsible for doing all necessary testing for the customer's applications and products using NXP Semiconductors products in order to avoid a default of the applications and the products or of the application or use by customer's third party customer(s). NXP does not accept any liability in this respect.

Limiting values — Stress above one or more limiting values (as defined in the Absolute Maximum Ratings System of IEC 60134) will cause permanent damage to the device. Limiting values are stress ratings only and (proper) operation of the device at these or any other conditions above those given in the Recommended operating conditions section (if present) or the Characteristics sections of this document is not warranted. Constant or repeated exposure to limiting values will permanently and irreversibly affect the quality and reliability of the device.

Terms and conditions of commercial sale — NXP Semiconductors products are sold subject to the general terms and conditions of commercial sale, as published at <http://www.nxp.com/profile/terms>, unless otherwise agreed in a valid written individual agreement. In case an individual agreement is concluded only the terms and conditions of the respective agreement shall apply. NXP Semiconductors hereby expressly objects to applying the customer's general terms and conditions with regard to the purchase of NXP Semiconductors products by customer.

No offer to sell or license — Nothing in this document may be interpreted or construed as an offer to sell products that is open for acceptance or the grant, conveyance or implication of any license under any copyrights, patents or other industrial or intellectual property rights.

Export control — This document as well as the item(s) described herein may be subject to export control regulations. Export might require a prior authorization from competent authorities.

Non-automotive qualified products — Unless this data sheet expressly states that this specific NXP Semiconductors product is automotive qualified, the product is not suitable for automotive use. It is neither qualified nor tested in accordance with automotive testing or application requirements. NXP Semiconductors accepts no liability for inclusion and/or use of non-automotive qualified products in automotive equipment or applications.

In the event that customer uses the product for design-in and use in automotive applications to automotive specifications and standards, customer (a) shall use the product without NXP Semiconductors' warranty of the

product for such automotive applications, use and specifications, and (b) whenever customer uses the product for automotive applications beyond NXP Semiconductors' specifications such use shall be solely at customer's own risk, and (c) customer fully indemnifies NXP Semiconductors for any liability, damages or failed product claims resulting from customer design and use of the product for automotive applications beyond NXP Semiconductors' standard warranty and NXP Semiconductors' product specifications.

14.4 Trademarks

Notice: All referenced brands, product names, service names and trademarks are the property of their respective owners.

15. Contact information

For more information, please visit: <http://www.nxp.com>

For sales office addresses, please send an email to: salesaddresses@nxp.com

16. Tables

Table 1. Ordering information	2	bit description	44
Table 2. Pin description	4	Table 35. DAC_CURRENT_1 register (address 12h)	
Table 3. Limiting values	6	bit description	44
Table 4. Thermal characteristics	6	Table 36. DAC_CURRENT_2 register (address 13h)	
Table 5. Characteristics	7	bit description	45
Table 6. Digital Layer Processing Latency	13	Table 37. DAC_CURRENT_3 register (address 14h)	
Table 7. Read or Write mode access description	24	bit description	45
Table 8. Number of bytes to be transferred	24	Table 38. DAC_SEL_PH_FINE register (address 15h)	
Table 9. SPI timing characteristics	25	bit description	45
Table 10. Interpolation filter coefficients	27	Table 39. PHASECORR_CNTRL0 register	
Table 11. Inversion filter coefficients	29	(address 16h) bit description	45
Table 12. DAC transfer function	29	Table 40. PHASECORR_CNTRL1 register	
Table 13. I _{O(fs)} coarse adjustment	31	(address 17h) bit description	45
Table 14. I _{O(fs)} fine adjustment	31	Table 41. DAC_A_AUX_MSB register (address 1Ah)	
Table 15. Digital offset adjustment	32	bit description	45
Table 16. Auxiliary DAC transfer function	33	Table 42. DAC_A_AUX_LSB register (address 1Bh)	
Table 17. Page 0 register allocation map	39	bit description	45
Table 18. COMMON register (address 00h) bit		Table 43. DAC_B_AUX_MSB register (address 1Ch)	
description	41	bit description	45
Table 19. TXCFG register (address 01h) bit description	41	Table 44. DAC_B_AUX_LSB register (address 1Dh)	
Table 20. PLLCFG register (address 02h) bit description	42	bit description	46
Table 21. FREQNCO_LSB register (address 03h) bit		Table 45. DAC_B_AUX_LSB register (address 1Dh)	
description	42	bit description	46
Table 22. FREQNCO_LISB register (address 04h) bit		Table 46. Bias current control table	46
description	42	Table 47. Page 1 register allocation map	47
Table 23. FREQNCO_UISB register (address 05h) bit		Table 48. MDS_MAIN register (address 00h) bit	
description	42	description	48
Table 24. FREQNCO_MSB register (address 06h) bit		Table 49. MDS_WIN_PERIOD_A register	
description	43	(address 01h) bit description	48
Table 25. PHINCO_LSB register (address 07h) bit		Table 50. MDS_WIN_PERIOD_B register	
description	43	(address 02h) bit description	48
Table 26. PHINCO_MSB register (address 08h) bit		Table 51. MDS_MISCCNTRL0 register	
description	43	(address 03h) bit description	49
Table 27. DAC_A_CFG_1 register (address 09h) bit		Table 52. MDS_MAN_ADJUSTDLY register	
description	43	(address 04h) bit description	49
Table 28. DAC_A_CFG_2 register (address 0Ah) bit		Table 53. MDS_AUTO_CYCLES register	
description	43	(address 05h) bit description	49
Table 29. DAC_A_CFG_3 register (address 0Bh) bit		Table 54. MDS_MISCCNTRL1 register (address 06h)	
description	43	bit description	49
Table 30. DAC_B_CFG_1 register (address 0Ch) bit		Table 55. MDS_ADJDELAY register (address 08h) bit	
description	44	description	50
Table 31. DAC_B_CFG_2 register (address 0Dh) bit		Table 56. MDS_STATUS0 register (address 09h) bit	
description	44	description	50
Table 32. DAC_B_CFG_3 register (address 0Eh) bit		Table 57. MDS_STATUS1 register (address 0Ah) bit	
description	44	description	51
Table 33. DAC_CFG register (address 0Fh) bit		Table 58. PAGE_ADDRESS register (address 1Fh)	
description	44	bit description	51
Table 34. DAC_CURRENT_0 register (address 11h)		Table 59. Page 2 register allocation map	52

continued >>

Table 60. MAINCONTROL register (address 00h) bit description	53	description	62
Table 61. JCLK_CNTRL register (address 03h) bit description	53	Table 88. MAN_ALIGN_LN_0_1 register (address 09h) bit description	62
Table 62. RST_EXT_FCLK register (address 04h) bit description	54	Table 89. MAN_ALIGN_LN_2_3 register (address 0Ah) bit description	63
Table 63. RST_EXT_DCLK register (address 05h) bit description	54	Table 90. FA_ERR_HANDLING register (address 0Bh) bit description	63
Table 64. DCSMU_PREDIVCNT register (address 06h) bit description	54	Table 91. SYNCOUT_MODE register (address 0Ch) bit description	64
Table 65. PLL_CHARGETIME register (address 07h) bit description	54	Table 92. LANE_POLARITY register (address 0Dh) bit description	64
Table 66. PLL_RUN_IN_TIME register (address 08h) bit description	54	Table 93. LANE_SELECT register (address 0Eh) bit description	65
Table 67. CA_RUN_IN_TIME register (address 09h) bit description	54	Table 94. SOFT_RESET_SCRAMBLER register (address 10h) bit description	65
Table 68. SET_VCM_VOLTAGE register (address 16h) bit description	54	Table 95. INIT_SCR_S15T8_LN0 register (address 11h) bit description	65
Table 69. SET_SYNC register (address 17h) bit description	54	Table 96. INIT_SCR_S7T1_LN0 (address 12h) bit description	66
Table 70. TYPE_ID register (address 1Bh) bit description	55	Table 97. INIT_SCR_S15T8_LN1 register (address 13h) bit description	66
Table 71. DAC_VERSION register (address 1Ch) bit description	55	Table 98. INIT_SCR_S7T1_LN1 register (address 14h) bit description	66
Table 72. DIG_VERSION register (address 1Dh) bit description	55	Table 99. INIT_SCR_S15T8_LN2 register (address 15h) bit description	66
Table 73. JRX_ANA_VERSION register (address 1Eh) bit description	55	Table 100. INIT_SCR_S7T1_LN2 register (address 16h) bit description	66
Table 74. PAGE_ADDRESS register (address 1Fh) bit description	55	Table 101. INIT_SCR_S15T8_LN3 register (address 17h) bit description	66
Table 75. Lane common-mode voltage adjustment	56	Table 102. INIT_SCR_S7T1_LN3 register (address 18h) bit description	66
Table 76. SYNC common-mode voltage adjustment	56	Table 103. INIT_ILA_BUFPTR_LN01 register (address 19h) bit description	66
Table 77. SYNC swing voltage adjustment	56	Table 104. INIT_ILA_BUFPTR_LN23 register (address 1Ah) bit description	66
Table 78. Page 4 register allocation map	57	Table 105. ERROR_HANDLING register (address 1Bh) bit description	67
Table 79. SR_DLP_0 register (address 00h) bit description	59	Table 106. REINIT_CNTRL register (address 1Ch) bit description	67
Table 80. SR_DLP_1 register (address 01h) bit description	59	Table 107. PAGE_ADDRESS register (address 1Fh) bit description	68
Table 81. FORCE_LOCK register (address 02h) bit description	59	Table 108. Page 5 register allocation map	69
Table 82. MAN_LOCK_LN_1_0 register (address 03h) bit description	60	Table 109. ILA_MON_1_0 register (address 00h) bit description	71
Table 83. MAN_LOCK_2_0 register (address 04h) bit description	60	Table 110. ILA_MON_3_2 register (address 01h) bit description	71
Table 84. CA_CNTRL register (address 05h) bit description	60	Table 111. ILA_BUF_ERR register (address 02h) bit description	71
Table 85. SCR_CNTRL register (address 06h) bit description	61	Table 112. CA_MON register (address 03h) bit description	71
Table 86. ILA_CNTRL register (address 07h) bit description	62	Table 113. DEC_FLAGS register (address 04h) bit description	71
Table 87. FORCE_ALIGN register (address 08h) bit description	62		

continued >>

description	72	Table 139. DBG_CNTRL register (address 1Eh) bit description	77
Table 114. KOUT_FLAG register (address 05h) bit description	72	Table 140. PAGE_ADDRESS register (address 1Fh) bit description	77
Table 115. K28_LN0_FLAG register (address 06h) bit description	72	Table 141. Counter source	77
Table 116. K28_LN1_FLAG register (address 07h) bit description	72	Table 142. Code group synchronization state machine	77
Table 117. K28_LN2_FLAG register (address 08h) bit description	72	Table 143. Page 6 register allocation map	78
Table 118. K28_LN3_FLAG register (address 09h) bit description	73	Table 144. LN0_CFG_0 register (address 00h) bit description	80
Table 119. KOUT_UNEXPECTED_FLAG register (address 0Ah) bit description	73	Table 145. LN0_CFG_1 register (address 01h) bit description	80
Table 120. LOCK_CNT_MON_LN01 register (address 0Bh) bit description	73	Table 146. LN0_CFG_2 register (address 02h) bit description	80
Table 121. LOCK_CNT_MON_LN23 register (address 0Ch) bit description	73	Table 147. LN0_CFG_3 register (address 03h) bit description	80
Table 122. CS_STATE_LNX register (address 0Dh) bit description	73	Table 148. LN0_CFG_4 register (address 04h) bit description	80
Table 123. RST_BUF_ERR_FLAGS register (address 0Eh) bit description	73	Table 149. LN0_CFG_5 register (address 05h) bit description	80
Table 124. INTR_MISC_ENA register (address 0Fh) bit description	74	Table 150. LN0_CFG_6 register (address 06h) bit description	80
Table 125. FLAG_CNT_LSB_LN0 register (address 10h) bit description	74	Table 151. LN0_CFG_7 register (address 07h) bit description	80
Table 126. FLAG_CNT_MSB_LN0 register (address 11h) bit description	74	Table 152. LN0_CFG_8 register (address 08h) bit description	81
Table 127. FLAG_CNT_LSB_LN1 register (address 12h) bit description	74	Table 153. LN0_CFG_9 register (address 09h) bit description	81
Table 128. FLAG_CNT_MSB_LN1 register (address 13h) bit description	74	Table 154. LN0_CFG_10 register (address 0Ah) bit description	81
Table 129. FLAG_CNT_LSB_LN2 register (address 14h) bit description	74	Table 155. LN0_CFG_11 register (address 0Bh) bit description	81
Table 130. FLAG_CNT_MSB_LN2 register (address 15h) bit description	74	Table 156. LN0_CFG_12 register (address 0Ch) bit description	81
Table 131. FLAG_CNT_LSB_LN3 register (address 16h) bit description	74	Table 157. LN0_CFG_13 register (address 0Dh) bit description	81
Table 132. FLAG_CNT_MSB_LN3 register (address 17h) bit description	75	Table 158. LN1_CFG_0 register (address 10h) bit description	81
Table 133. BER_LEVEL_LSB register (address 18h) bit description	75	Table 159. LN1_CFG_1 register (address 11h) bit description	81
Table 134. BER_LEVEL_MSB register (address 19h) bit description	75	Table 160. LN1_CFG_2 register (address 12h) bit description	81
Table 135. INTR_ENA register (address 1Ah) bit description	75	Table 161. LN1_CFG_3 register (address 13h) bit description	82
Table 136. CNTRL_FLAGCNT_LN01 register (address 1Bh) bit description	76	Table 162. LN1_CFG_4 register (address 14h) bit description	82
Table 137. CNTRL_FLAGCNT_LN23 register (address 1Ch) bit description	76	Table 163. LN1_CFG_5 register (address 15h) bit description	82
Table 138. MON_FLAGS_RESET register (address 1Dh) bit description	76	Table 164. LN1_CFG_6 register (address 16h) bit description	82
		Table 165. LN1_CFG_7 register (address 17h) bit description	82

continued >>

Table 166. LN1_CFG_8 register (address 18h) bit description	82	description	88
Table 167. LN1_CFG_9 register (address 19h) bit description	82	Table 196. LN3_CFG_8 register (address 18h) bit description	88
Table 168. LN1_CFG_10 register (address 1Ah) bit description	82	Table 197. LN3_CFG_9 register (address 19h) bit description	88
Table 169. LN1_CFG_11 register (address 1Bh) bit description	83	Table 198. LN3_CFG_10 register (address 1Ah) bit description	88
Table 170. LN1_CFG_12 register (address 1Ch) bit description	83	Table 199. LN3_CFG_11 register (address 1Bh) bit description	89
Table 171. LN1_CFG_13 register (address 1Dh) bit description	83	Table 200. LN3_CFG_12 register (address 1Ch) bit description	89
Table 172. PAGE_ADDRESS register (address 1Fh) bit description	83	Table 201. LN3_CFG_13 register (address 1Dh) bit description	89
Table 173. Page 7 register allocation map	84	Table 202. PAGE_ADDRESS register (address 1Fh) bit description	89
Table 174. LN2_CFG_0 register (address 00h) bit description	86	Table 203. Abbreviations	91
Table 175. LN2_CFG_1 register (address 01h) bit description	86	Table 204. Revision history	92
Table 176. LN2_CFG_2 register (address 02h) bit description	86		
Table 177. LN2_CFG_3 register (address 03h) bit description	86		
Table 178. LN2_CFG_4 register (address 04h) bit description	86		
Table 179. LN2_CFG_5 register (address 05h) bit description	86		
Table 180. LN2_CFG_6 register (address 06h) bit description	86		
Table 181. LN2_CFG_7 register (address 07h) bit description	86		
Table 182. LN2_CFG_8 register (address 08h) bit description	87		
Table 183. LN2_CFG_9 register (address 09h) bit description	87		
Table 184. LN2_CFG_10 register (address 0Ah) bit description	87		
Table 185. LN2_CFG_11 register (address 0Bh) bit description	87		
Table 186. LN2_CFG_12 register (address 0Ch) bit description	87		
Table 187. LN2_CFG_13 register (address 0Dh) bit description	87		
Table 188. LN3_CFG_0 register (address 10h) bit description	87		
Table 189. LN3_CFG_1 register (address 11h) bit description	87		
Table 190. LN3_CFG_2 register (address 12h) bit description	87		
Table 191. LN3_CFG_3 register (address 13h) bit description	88		
Table 192. LN3_CFG_4 register (address 14h) bit description	88		
Table 193. LN3_CFG_5 register (address 15h) bit description	88		
Table 194. LN3_CFG_6 register (address 16h) bit description	88		
Table 195. LN3_CFG_7 register (address 17h) bit description	88		

17. Contents

1	General description	1	10.13.2	DC interface to an Analog Quadrature Modulator (AQM)	35
2	Features and benefits	1	10.13.3	AC interface to an Analog Quadrature Modulator (AQM)	37
3	Applications	2	10.13.4	Phase correction	38
4	Ordering information	2	10.14	Power and grounding	38
5	Block diagram	3	10.15	Configuration interface	38
6	Pinning information	4	10.15.1	Register description	38
6.1	Pinning	4	10.15.2	Detailed descriptions of registers	38
6.2	Pin description	4	10.15.2.1	Page 0 allocation map description	39
7	Limiting values	6	10.15.2.2	Page 0 bit definition detailed description	41
8	Thermal characteristics	6	10.15.2.3	Page 1 allocation map description	47
9	Characteristics	7	10.15.2.4	Page 1 bit definition detailed description	48
10	Application information	12	10.15.2.5	Page 2 allocation map description	52
10.1	General description	12	10.15.2.6	Page 2 bit definition detailed description	53
10.2	JESD204A receiver	13	10.15.2.7	Page 4 allocation map description	57
10.2.1	Lane input	14	10.15.2.8	Page 4 bit definition detailed description	59
10.2.2	Sync and word align	14	10.15.2.9	Page 5 allocation map description	69
10.2.3	Comma detection and word align	15	10.15.2.10	Page 5 bit definition detailed description	71
10.2.4	Descrambler	16	10.15.2.11	Page 6 allocation map description	78
10.2.5	Inter-lane alignment	16	10.15.2.12	Page 6 bit definition detailed description	80
10.2.5.1	Single device operation	16	10.15.2.13	Page 7 allocation map description	84
10.2.5.2	Multi-device operation	16	10.15.2.14	Page 7 bit definition detailed description	86
10.2.5.3	Master/slave mode	18	11	Package outline	90
10.2.5.4	All slave mode	21	12	Abbreviations	91
10.2.6	Frame assembly	22	13	Revision history	92
10.3	Serial Peripheral Interface (SPI)	24	14	Legal information	93
10.3.1	Protocol description	24	14.1	Data sheet status	93
10.3.2	SPI timing description	25	14.2	Definitions	93
10.4	Clock input	26	14.3	Disclaimers	93
10.5	FIR filters	27	14.4	Trademarks	94
10.6	Quadrature modulator and Numerically Controlled Oscillator (NCO)	28	15	Contact information	94
10.6.1	NCO in 32-bit	28	16	Tables	95
10.6.2	Low-power NCO	28	17	Contents	99
10.6.3	Minus_3dB	28			
10.7	$x / (\sin x)$	28			
10.8	DAC transfer function	29			
10.9	Full-scale current	30			
10.9.1	Regulation	30			
10.9.1.1	External regulation	30			
10.9.2	Full-scale current adjustment	30			
10.10	Digital offset correction	31			
10.11	Analog output	32			
10.12	Auxiliary DACs	33			
10.13	Output configuration	34			
10.13.1	Basic output configuration	34			

Please be aware that important notices concerning this document and the product(s) described herein, have been included in section 'Legal information'.