

ADC1005S060

Single 10 bits ADC, up to 60 MHz

Rev. 02 — 13 August 2008

Product data sheet

1. General description

The ADC1005S060 is a 10-bit high-speed low-power Analog-to-Digital Converter (ADC) for professional video and other applications. It converts the analog input signal into 10-bit binary or gray coded digital words at a maximum sampling rate of 60 MHz. All digital inputs and outputs are Transistor-Transistor Logic (TTL) and CMOS compatible, although a low-level sine wave clock input signal is allowed.

The device requires an external source to drive its reference ladder.

2. Features

- 10-bit resolution (binary or gray code)
- Sampling rate up to 60 MHz
- DC sampling allowed
- One clock cycle conversion only
- High signal-to-noise ratio over a large analog input frequency range (9.3 effective bits at 5 MHz full-scale input at $f_{\text{clk}} = 60$ MHz)
- No missing codes guaranteed
- In-Range (IR) CMOS output
- TTL and CMOS levels compatible digital inputs
- 2.7 V to 3.6 V CMOS digital outputs
- Low-level AC clock input signal allowed
- External reference voltage regulator
- Power dissipation only 312 mW (typical)
- Low analog input capacitance, no buffer amplifier required
- No sample-and-hold circuit required

3. Applications

- Video data digitizing
- Radar
- Barcode scanners
- Digital instrumentation
- Transient signal analysis
- $\Sigma\Delta$ modulators
- Medical imaging

4. Quick reference data

Table 1. Quick reference data

$V_{CCA} = 4.75\text{ V to }5.25\text{ V}$; $V_{CCD} = 4.75\text{ V to }5.25\text{ V}$; AGND and DGND shorted together;
 $T_{amb} = 0\text{ }^{\circ}\text{C to }70\text{ }^{\circ}\text{C}$; typical values measured at $V_{CCA} = V_{CCD} = 5\text{ V}$; $V_{CCO} = 3.3\text{ V}$; $V_{RB} = 1.3\text{ V}$;
 $V_{RT} = 3.7\text{ V}$; $C_L = 10\text{ pF}$ and $T_{amb} = 25\text{ }^{\circ}\text{C}$ unless otherwise specified.

Symbol	Parameter	Conditions	Min	Typ	Max	Unit
V_{CCA}	analog supply voltage		4.75	5.0	5.25	V
V_{CCD}	digital supply voltage		4.75	5.0	5.25	V
V_{CCO}	output supply voltage		2.7	3.3	3.6	V
I_{CCA}	analog supply current		-	29	37	mA
I_{CCD}	digital supply current		-	33	40	mA
I_{CCO}	output supply current	$f_{clk} = 60\text{ MHz}$; ramp input	-	0.5	2.0	mA
INL	integral non-linearity		-	± 0.8	± 2.0	LSB
DNL	differential non-linearity		-	± 0.35	± 0.9	LSB
$f_{clk(max)}$	maximum clock frequency		60	-	-	MHz
P_{tot}	total power dissipation	$f_{clk} = 60\text{ MHz}$; ramp input	-	312	411	mW

5. Ordering information

Table 2. Ordering information

Type number	Package		Version
	Name	Description	
ADC1005S060TS	SSOP28	plastic shrink small outline package; 28 leads; body width 5.3 mm	SOT341-1

6. Block diagram

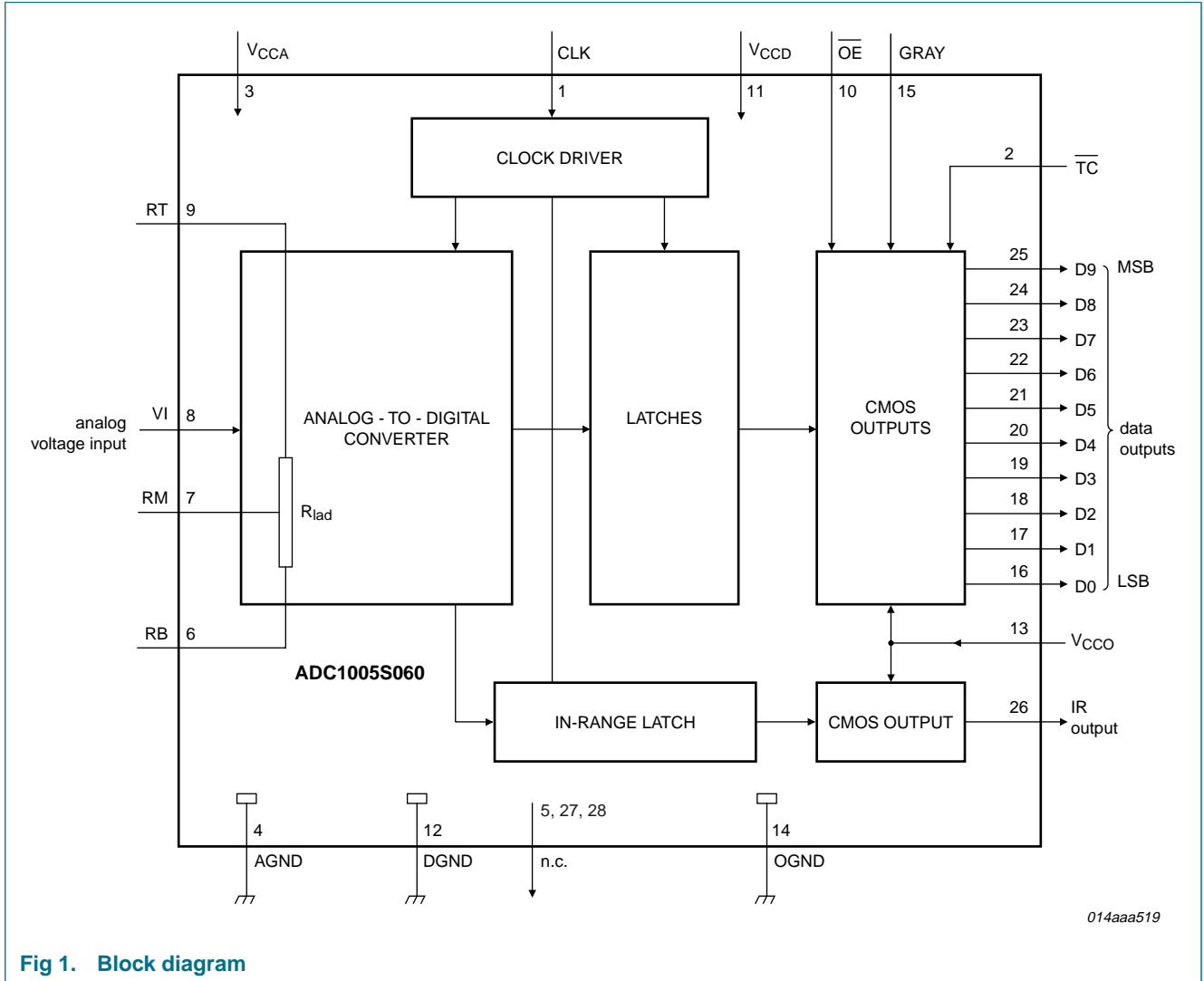
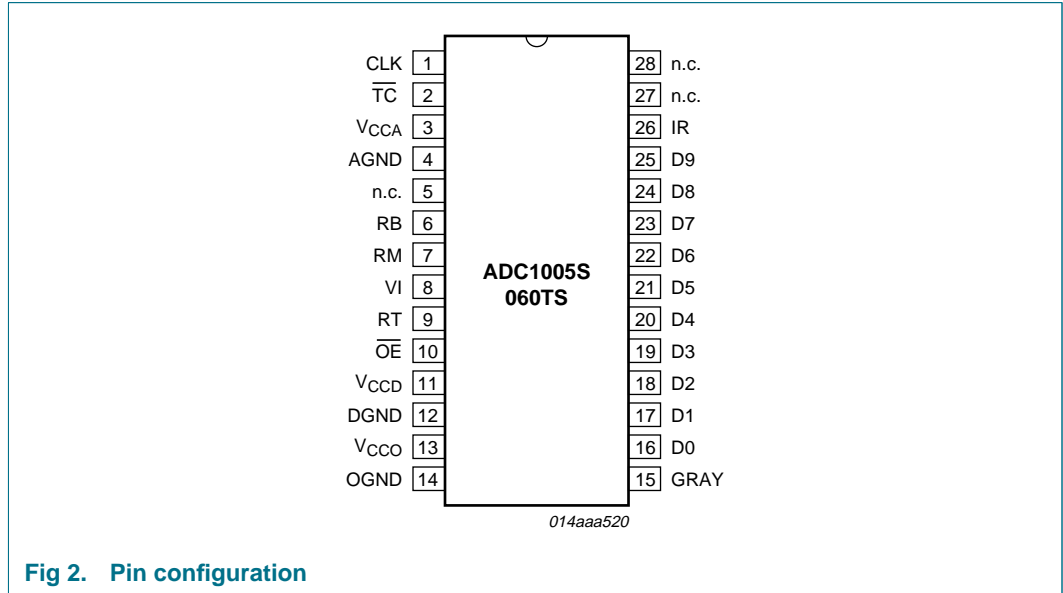

Fig 1. Block diagram

7. Pinning information

7.1 Pinning



7.2 Pin description

Table 3. Pin description

Symbol	Pin	Description
CLK	1	clock input
\overline{TC}	2	twos complement input (active LOW)
V_{CCA}	3	analog supply voltage (5 V)
AGND	4	analog ground
n.c.	5	not connected
RB	6	reference voltage BOTTOM input
RM	7	reference voltage MIDDLE input
VI	8	analog voltage input
RT	9	reference voltage TOP input
\overline{OE}	10	output enable input (active LOW)
V_{CCD}	11	digital supply voltage (2.7 V to 3.6 V)
DGND	12	digital ground
V_{CCO}	13	supply voltage for output stages (2.7 V to 3.6 V)
OGND	14	output ground
GRAY	15	gray code input (active HIGH)
D0	16	data output; bit 0 (Least Significant Bit (LSB))
D1	17	data output; bit 1
D2	18	data output; bit 2
D3	19	data output; bit 3

Table 3. Pin description ...continued

Symbol	Pin	Description
D4	20	data output; bit 4
D5	21	data output; bit 5
D6	22	data output; bit 6
D7	23	data output; bit 7
D8	24	data output; bit 8
D9	25	data output; bit 9 (Most Significant Bit (MSB))
IR	26	in-range data output
n.c.	27	not connected
n.c.	28	not connected

8. Limiting values

Table 4. Limiting values

In accordance with the Absolute Maximum Rating System (IEC 60134).

Symbol	Parameter	Conditions	Min	Max	Unit
V_{CCA}	analog supply voltage		[1] -0.3	+7.0	V
V_{CCD}	digital supply voltage		[1] -0.3	+7.0	V
V_{CCO}	output supply voltage		[1] -0.3	+7.0	V
ΔV_{CC}	supply voltage difference	$V_{CCA} - V_{CCD}$	-0.1	+1.0	V
		$V_{CCD} - V_{CCO};$ $V_{CCA} - V_{CCO}$	-0.1	+4.0	V
V_I	input voltage	referenced to AGND	-0.3	+7.0	V
$V_{i(\text{clk})(\text{p-p})}$	peak-to-peak clock input voltage	for switching; referenced to DGND	-	V_{CCD}	V
I_O	output current		-	10	mA
T_{stg}	storage temperature		-55	+150	°C
T_{amb}	ambient temperature		-40	+85	°C
T_j	junction temperature		-	150	°C

[1] The supply voltages V_{CCA} , V_{CCD} and V_{CCO} may have any value between -0.3 V and +7.0 V provided that the supply voltage differences ΔV_{CC} are respected.

9. Thermal characteristics

Table 5. Thermal characteristics

Symbol	Parameter	Condition	Value	Unit
$R_{\text{th}(j-a)}$	thermal resistance from junction to ambient	in free air	110	K/W

10. Characteristics

Table 6. Characteristics

$V_{CCA} = 4.75\text{ V to }5.25\text{ V}$; $V_{CCD} = 4.75\text{ V to }5.25\text{ V}$; AGND and DGND shorted together; $T_{amb} = 0\text{ }^{\circ}\text{C to }70\text{ }^{\circ}\text{C}$; typical values measured at $V_{CCA} = V_{CCD} = 5\text{ V}$; $V_{CCO} = 3.3\text{ V}$; $V_{RB} = 1.3\text{ V}$; $V_{RT} = 3.7\text{ V}$; $C_L = 10\text{ pF}$ and $T_{amb} = 25\text{ }^{\circ}\text{C}$ unless otherwise specified.

Symbol	Parameter	Conditions	Min	Typ	Max	Unit
Supplies						
V_{CCA}	analog supply voltage		4.75	5.0	5.25	V
V_{CCD}	digital supply voltage		4.75	5.0	5.25	V
V_{CCO}	output supply voltage		2.7	3.3	3.6	V
ΔV_{CC}	supply voltage difference	$V_{CCA} - V_{CCD}$	-0.2	-	+0.2	V
		$V_{CCA} - V_{CCO}$; $V_{CCD} - V_{CCO}$	-0.2	-	+2.55	V
I_{CCA}	analog supply current		-	29	37	mA
I_{CCD}	digital supply current		-	33	40	mA
I_{CCO}	output supply current	$f_{clk} = 60\text{ MHz}$; ramp input	-	0.5	2.0	mA
P_{tot}	total power dissipation	$f_{clk} = 60\text{ MHz}$; ramp input	-	312	411	mW
Inputs						
Clock input CLK (Referenced to DGND) ^[1]						
V_{IL}	LOW-level input voltage		0	-	0.8	V
V_{IH}	HIGH-level input voltage		2	-	V_{CCD}	V
I_{IL}	LOW-level input current	$V_{clk} = 0.8\text{ V}$	-1	0	+1	μA
I_{IH}	HIGH-level input current	$V_{clk} = 2\text{ V}$	-	2	10	μA
C_i	input capacitance		-	2	-	pF
Inputs $\overline{\text{OE}}$, $\overline{\text{TC}}$ and GRAY (Referenced to DGND); see Table 3 and 4						
V_{IL}	LOW-level input voltage		0	-	0.8	V
V_{IH}	HIGH-level input voltage		2	-	V_{CCD}	V
I_{IL}	LOW-level input current	$V_{IL} = 0.8\text{ V}$	-1	-	-	μA
I_{IH}	HIGH-level input current	$V_{IH} = 2.0\text{ V}$	-	-	1	μA
Analog input VI (Referenced to AGND)						
I_{IL}	LOW-level input current	$V_I = V_{RB} = 1.3\text{ V}$	-	0	-	μA

Table 6. Characteristics ...continued

$V_{CCA} = 4.75\text{ V to }5.25\text{ V}$; $V_{CCD} = 4.75\text{ V to }5.25\text{ V}$; AGND and DGND shorted together; $T_{amb} = 0\text{ }^{\circ}\text{C to }70\text{ }^{\circ}\text{C}$; typical values measured at $V_{CCA} = V_{CCD} = 5\text{ V}$; $V_{CCO} = 3.3\text{ V}$; $V_{RB} = 1.3\text{ V}$; $V_{RT} = 3.7\text{ V}$; $C_L = 10\text{ pF}$ and $T_{amb} = 25\text{ }^{\circ}\text{C}$ unless otherwise specified.

Symbol	Parameter	Conditions	Min	Typ	Max	Unit	
I_{IH}	HIGH-level input current	$V_I = V_{RT} = 3.7\text{ V}$	-	55	-	μA	
Y_i	input admittance	$f_i = 5\text{ MHz}$	[2]				
		R_i , input resistance	-	45	-	$\text{k}\Omega$	
		C_i , input capacitance	3	5	7	pF	
Reference voltages for the resistor ladder; see Table 7							
V_{RB}	voltage on pin RB		1.2	1.3	2.2	V	
V_{RT}	voltage on pin RT		3.4	3.7	$V_{CCA} - 0.8$	V	
$V_{ref(dif)}$	differential reference voltage	$V_{RT} - V_{RB}$	2.2	2.4	3.2	V	
I_{ref}	reference current	$V_{ref(dif)} = 2.4\text{ V}$	-	17.6	-	mA	
R_{lad}	ladder resistance		-	136	-	Ω	
TC_{Rlad}	ladder resistor temperature coefficient		-	253	-	$\text{m}\Omega/\text{K}$	
V_{offset}	offset voltage	$V_{ref(dif)} = 2.4\text{ V}$					
		BOTTOM	[3]	-	200	-	mV
		TOP	[3]	-	190	-	mV
$V_{i(a)(p-p)}$	peak-to-peak analog input voltage	$V_{ref(dif)} = 2.4\text{ V}$	[4] 1.95	2.01	2.10	V	

Outputs

Digital outputs D9 to D0 and IR (Referenced to OGND)

V_{OL}	LOW-level output voltage	$I_O = 1\text{ mA}$	0	-	0.5	V
V_{OH}	HIGH-level output voltage	$I_O = -1\text{ mA}$	$V_{CCO} - 0.5$	-	V_{CCO}	V
I_{OZ}	OFF-state output current	$0.5\text{ V} < V_O < V_{CCO}$	-20	-	+20	μA

Switching characteristics; Clock input CLK; see Figure 4[1]

$f_{clk(max)}$	maximum clock frequency		60	-	-	MHz
$t_{w(clk)H}$	HIGH clock pulse width	$T_{amb} = 25\text{ }^{\circ}\text{C}$	7.0	-	-	ns
$t_{w(clk)L}$	LOW clock pulse width	$T_{amb} = 25\text{ }^{\circ}\text{C}$	3.5	-	-	ns

Analog signal processing; $f_{clk} = 60\text{ MHz}$

Linearity

INL	integral non-linearity	ramp input	-	± 0.8	± 2.0	LSB
DNL	differential non-linearity	ramp input	-	± 0.35	± 0.9	LSB

Table 6. Characteristics ...continued

$V_{CCA} = 4.75\text{ V to }5.25\text{ V}$; $V_{CCD} = 4.75\text{ V to }5.25\text{ V}$; AGND and DGND shorted together; $T_{amb} = 0\text{ }^{\circ}\text{C to }70\text{ }^{\circ}\text{C}$; typical values measured at $V_{CCA} = V_{CCD} = 5\text{ V}$; $V_{CCO} = 3.3\text{ V}$; $V_{RB} = 1.3\text{ V}$; $V_{RT} = 3.7\text{ V}$; $C_L = 10\text{ pF}$ and $T_{amb} = 25\text{ }^{\circ}\text{C}$ unless otherwise specified.

Symbol	Parameter	Conditions	Min	Typ	Max	Unit
E_{offset}	offset error	middle code	-	± 1	-	LSB
E_G	gain error	from device to device	[5] -	± 0.5	-	%
Bandwidth						
B	bandwidth	full-scale sine wave	[6] -	30	-	MHz
		75 % full-scale sine wave	-	45	-	MHz
		small signal at mid-scale; $V_I = \pm 10\text{ LSB}$ at code 512	-	700	-	MHz
$t_{s(LH)}$	LOW to HIGH settling time	full-scale square wave; see Figure 6	[7] -	5	-	ns
$t_{s(HL)}$	HIGH to LOW settling time	full-scale square wave; see Figure 6	[7] -	5	-	ns
Harmonics						
α_{2H}	second harmonic level	$f_i = 5\text{ MHz}$	-	-68	-	dB
α_{3H}	third harmonic level	$f_i = 5\text{ MHz}$	-	-67	-	dB
THD	total harmonic distortion	$f_i = 5\text{ MHz}$	-	-64	-	dB
		$f_i = 15\text{ MHz}$	-	-57	-	dB
SFDR	spurious free dynamic range	$f_i = 5\text{ MHz}$	-	72	-	dB
Signal-to-Noise ratio [8]						
S/N	signal-to-noise ratio	without harmonics; $f_i = 5\text{ MHz}$	-	58	-	dB
		without harmonics; $f_i = 15\text{ MHz}$	53	57	-	dB
Effective bits [8]						
ENOB	effective number of bits	$f_i = 5\text{ MHz}$	-	9.3	-	bits
		$f_i = 10\text{ MHz}$	-	8.9	-	bits
		$f_i = 15\text{ MHz}$	-	8.8	-	bits
		$f_i = 20\text{ MHz}$	-	8.6	-	bits
Two-tone intermodulation [9]						
α_{IM}	intermodulation suppression	$f_{clk} = 60\text{ MHz}$	-	-67	-	dB
Bit error rate						
BER	bit error rate	$f_i = 5\text{ MHz}$; $V_I = \pm 16\text{ LSB}$ at code 512	-	10^{-13}	-	times/samples
Timing ($f_{clk} = 60\text{ MHz}$; $C_L = 10\text{ pF}$); see Figure 4 [10]						
$t_{d(s)}$	sampling delay time		-	0.7	2	ns
$t_{h(o)}$	output hold time		4	-	-	ns
$t_{d(o)}$	output delay time	$V_{CCO} = 2.7\text{ V}$	-	10	14	ns
		$V_{CCO} = 3.3\text{ V}$	-	9	13	ns

Table 6. Characteristics ...continued

$V_{CCA} = 4.75\text{ V to }5.25\text{ V}$; $V_{CCD} = 4.75\text{ V to }5.25\text{ V}$; AGND and DGND shorted together; $T_{amb} = 0\text{ }^{\circ}\text{C to }70\text{ }^{\circ}\text{C}$; typical values measured at $V_{CCA} = V_{CCD} = 5\text{ V}$; $V_{CCO} = 3.3\text{ V}$; $V_{RB} = 1.3\text{ V}$; $V_{RT} = 3.7\text{ V}$; $C_L = 10\text{ pF}$ and $T_{amb} = 25\text{ }^{\circ}\text{C}$ unless otherwise specified.

Symbol	Parameter	Conditions	Min	Typ	Max	Unit
C_L	load capacitance		-	-	10	pF
SR	slew rate	$V_{CCO} = 2.7\text{ V}$	0.2	0.3	-	V/ns
3-state output delay times ($f_{clk} = 60\text{ MHz}$; $V_{CCO} = 3.3\text{ V}$); see Figure 5						
t_{dZH}	float to active HIGH delay time		-	16	20	ns
t_{dZL}	float to active LOW delay time		-	30	34	ns
t_{dHZ}	active HIGH to float delay time		-	25	30	ns
t_{dLZ}	active LOW to float delay time		-	23	27	ns

[1] The rise and fall times of the clock signal must not be less than 0.5 ns.

[2] The input admittance is $Y_i + \frac{I}{R_i} + j\omega C_i$

[3] Analog input voltages producing code 0 up to and including code 1023:

a) $V_{\text{offset BOTTOM}}$ is the difference between the analog input which produces data equal to 00 and the reference voltage on pin RB (V_{RB}) at $T_{amb} = 25\text{ }^{\circ}\text{C}$.

b) $V_{\text{offset TOP}}$ is the difference between the reference voltage on pin RT (V_{RT}) and the analog input which produces data outputs equal to code 1023 at $T_{amb} = 25\text{ }^{\circ}\text{C}$.

[4] To ensure the optimum linearity performance of such a converter architecture the lower and upper extremities of the converter reference resistor ladder are connected to pins RB and RT via offset resistors R_{OB} and R_{OT} as shown in [Figure 3](#).

a) The current flowing into the resistor ladder is $I = \frac{V_{RT} - V_{RB}}{R_{OB} + R_L + R_{OT}}$ and the full-scale input range at the converter, to cover code 0

to 1023 is $V_I = R_L \times I_L = \frac{R_L}{R_{OB} + R_L + R_{OT}} \times (V_{RT} + V_{RB}) = 0.8375 \times (V_{RT} - V_{RB})$

b) Since R_L , R_{OB} and R_{OT} have similar behavior with respect to process and temperature variation, the ratio $\frac{R_L}{R_{OB} + R_L + R_{OT}}$

will be kept reasonably constant from device to device. Consequently, variation of the output codes at a given input voltage depends mainly on the difference $V_{RT} - V_{RB}$ and its variation with temperature and supply voltage. When several ADCs are connected in parallel and fed with the same reference source, the matching between each of them is optimized.

[5] $E_G = \frac{(V_{1023} - V_0) - V_{i(p-p)}}{V_{i(p-p)}} \times 100$

[6] The analog bandwidth is defined as the maximum input sine wave frequency which can be applied to the device. No glitches greater than 2 LSB, neither any significant attenuation are observed in the reconstructed signal.

[7] The analog input settling time is the minimum time required for the input signal to be stabilized after a sharp full-scale input (square wave signal) in order to sample the signal and obtain correct output data.

[8] Effective bits are obtained via a Fast Fourier Transform (FFT) treatment taking 8000 acquisition points per equivalent fundamental period. The calculation takes into account all harmonics and noise up to half the clock frequency (Nyquist frequency). Conversion to signal-to-noise ratio: $S/N = \text{ENOB} \times 6.02 + 1.76\text{ dB}$.

[9] Intermodulation measured relative to either tone with analog input frequencies of 4.3 MHz and 4.5 MHz. The two input signals have the same amplitude and the total amplitude of both signals provides full-scale to the converter.

[10] Output data acquisition: the output data is available after the maximum delay time of $t_{d(o)}$. NXP recommends the lowest possible output load. These parameters are guaranteed by characterization and not by production test.

11. Additional information relating to [Table 6](#)

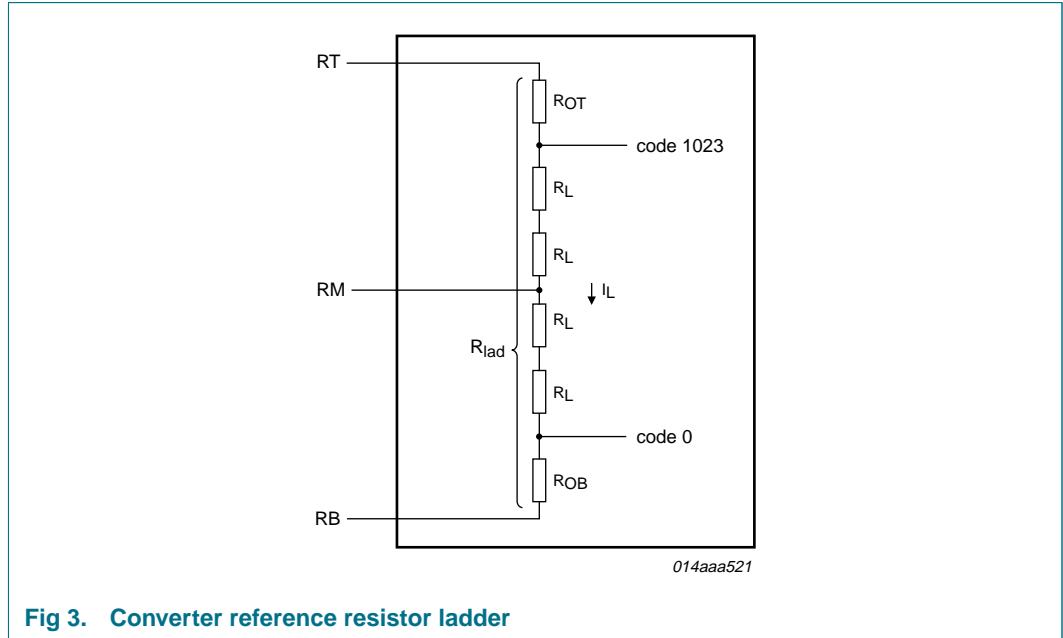

Fig 3. Converter reference resistor ladder

Table 7. Output coding and input voltage (typical values; referenced to AGND, $V_{RB} = 1.3 V$, $V_{RT} = 3.7 V$; binary/gray codes)

Code	$V_{i(a)(p-p)}$ (V)	IR	Binary outputs D9 to D0	Gray outputs D9 to D0
Underflow	< 1.5	0	00 0000 0000	00 0000 0000
0	1.5	1	00 0000 0000	00 0000 0000
1	-	1	00 0000 0001	00 0000 0001
↓	-	↓	↓	↓
1022	-	1	11 1111 1110	10 0000 0001
1023	3.51	1	11 1111 1111	10 0000 0000
Overflow	> 3.51	0	11 1111 1111	10 0000 0000

Table 8. Output coding and input voltage (typical values; referenced to AGND; binary/twos complement codes)

Code	$V_{i(a)(p-p)}$ (V)	IR	Binary outputs D9 to D0	twos complement outputs D9 to D0
Underflow	< 1.5	0	00 0000 0000	10 0000 0000
0	1.5	1	00 0000 0000	10 0000 0000
1	-	1	00 0000 0001	10 0000 0001
↓	-	↓	↓	↓
1022	-	1	11 1111 1110	01 1111 1110
1023	3.51	1	11 1111 1111	01 1111 1111
Overflow	> 3.51	0	11 1111 1111	01 1111 1111

Table 9. \overline{TC} mode selection

\overline{TC}	\overline{OE}	D9 to D0	IR
X	1	high impedance	high impedance
0	0	active; two's complement	active
1	0	active; binary	active

Table 10. Gray mode selection

Gray	\overline{OE}	D9 to D0	IR
X	1	high impedance	high impedance
0	0	active; binary	active
1	0	active; gray	active

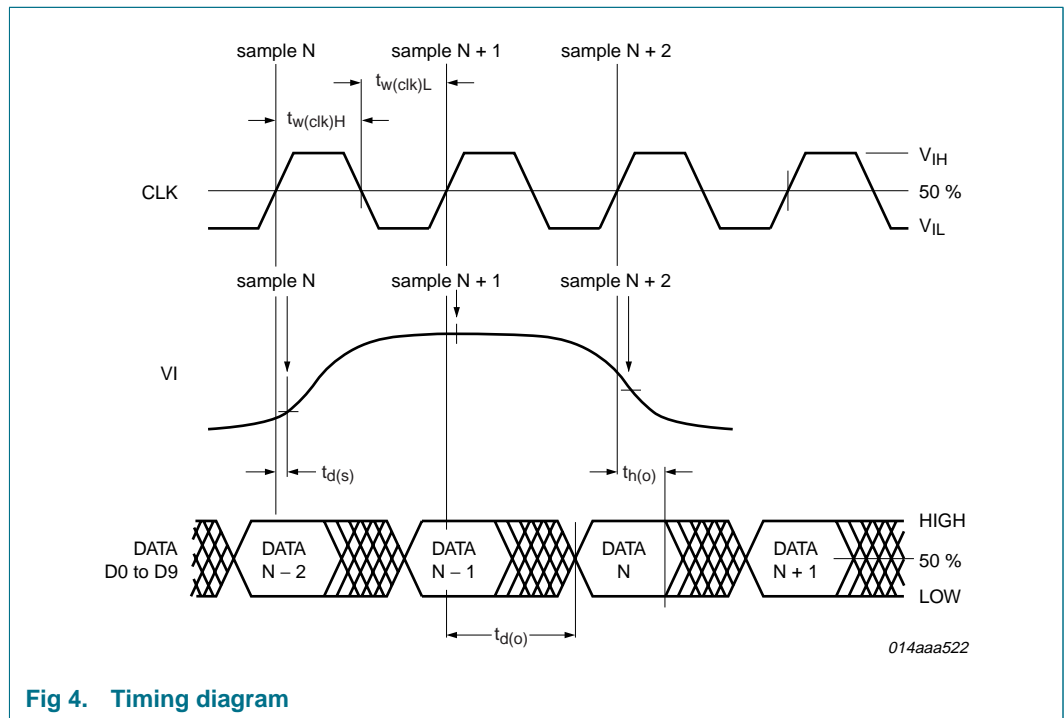
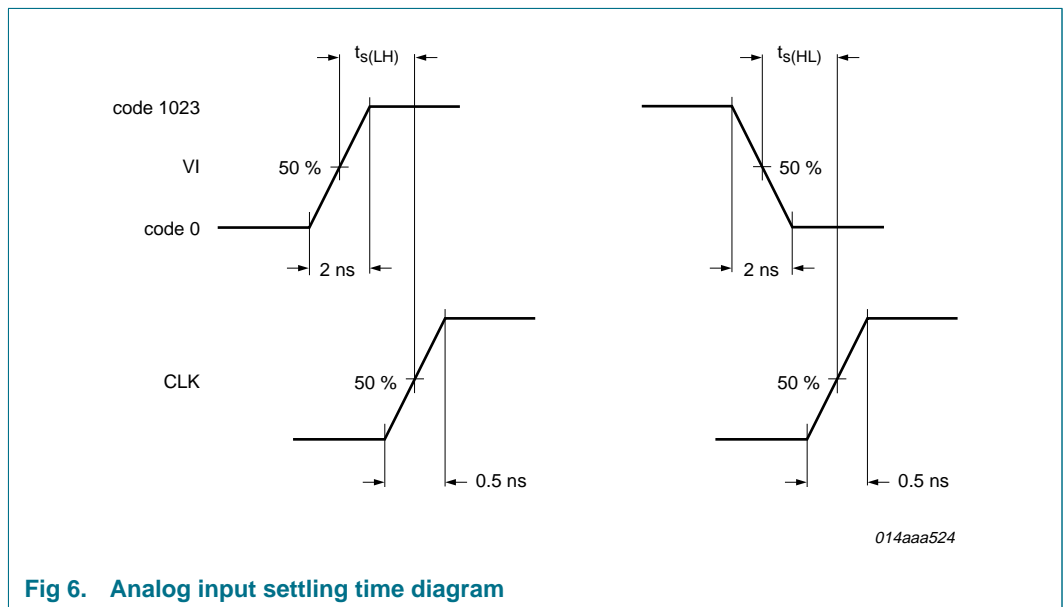
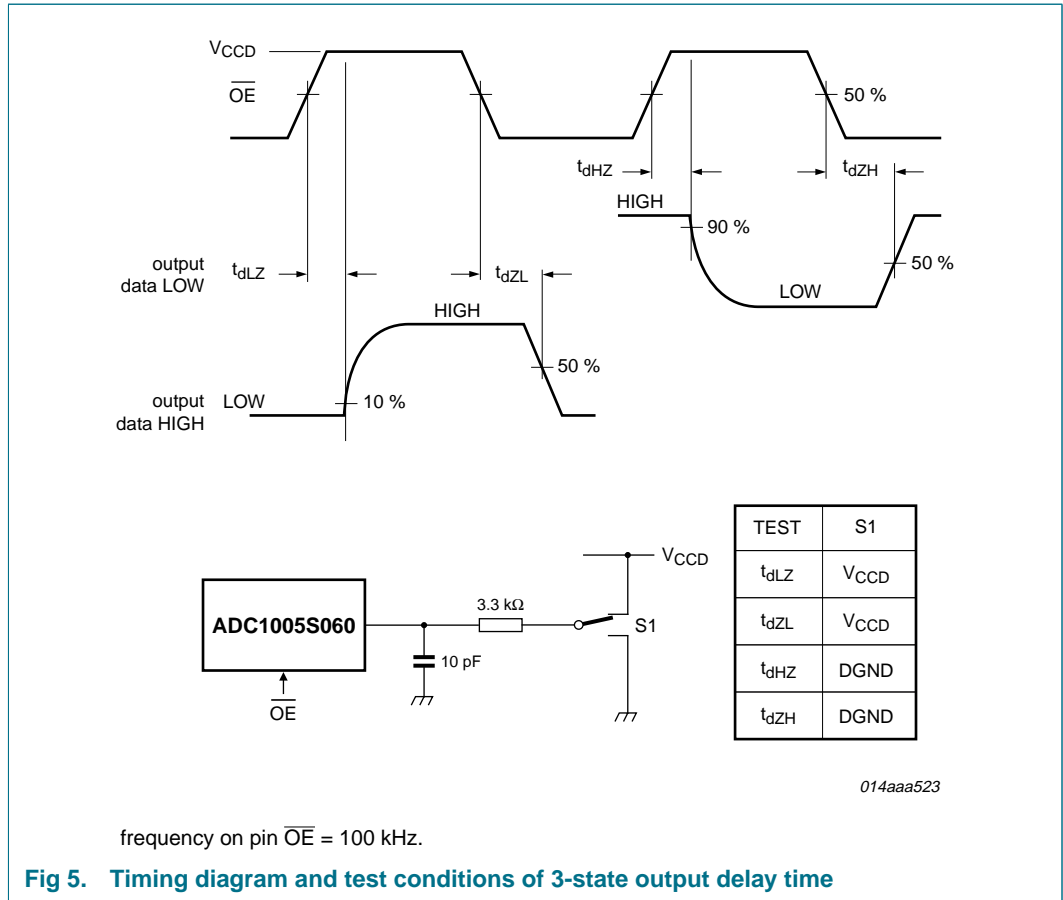
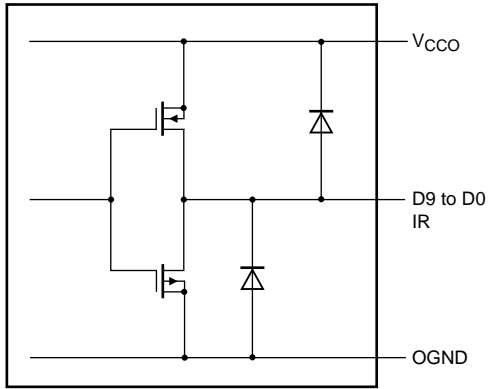

Fig 4. Timing diagram





014aaa525

Fig 7. D9 to D0 and IR outputs

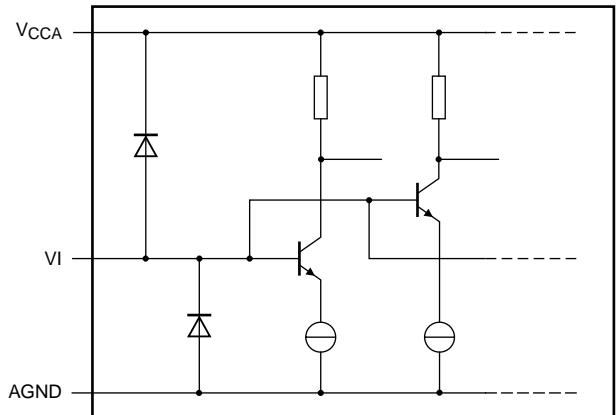

014aaa526

Fig 8. VI analog input

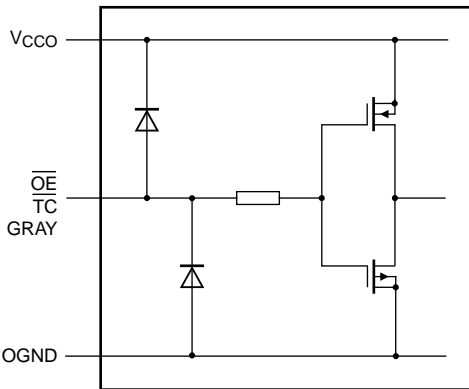

014aaa527

Fig 9. OE GRAY and TC inputs

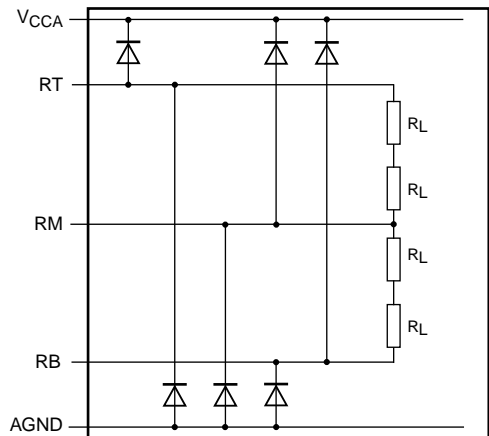

014aaa528

Fig 10. RB, RM and RT inputs

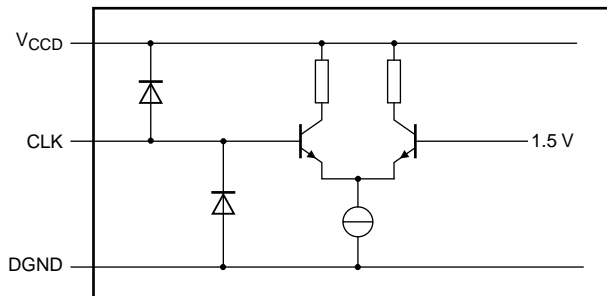

014aaa529

Fig 11. CLK input

12. Application information

12.1 Application diagrams

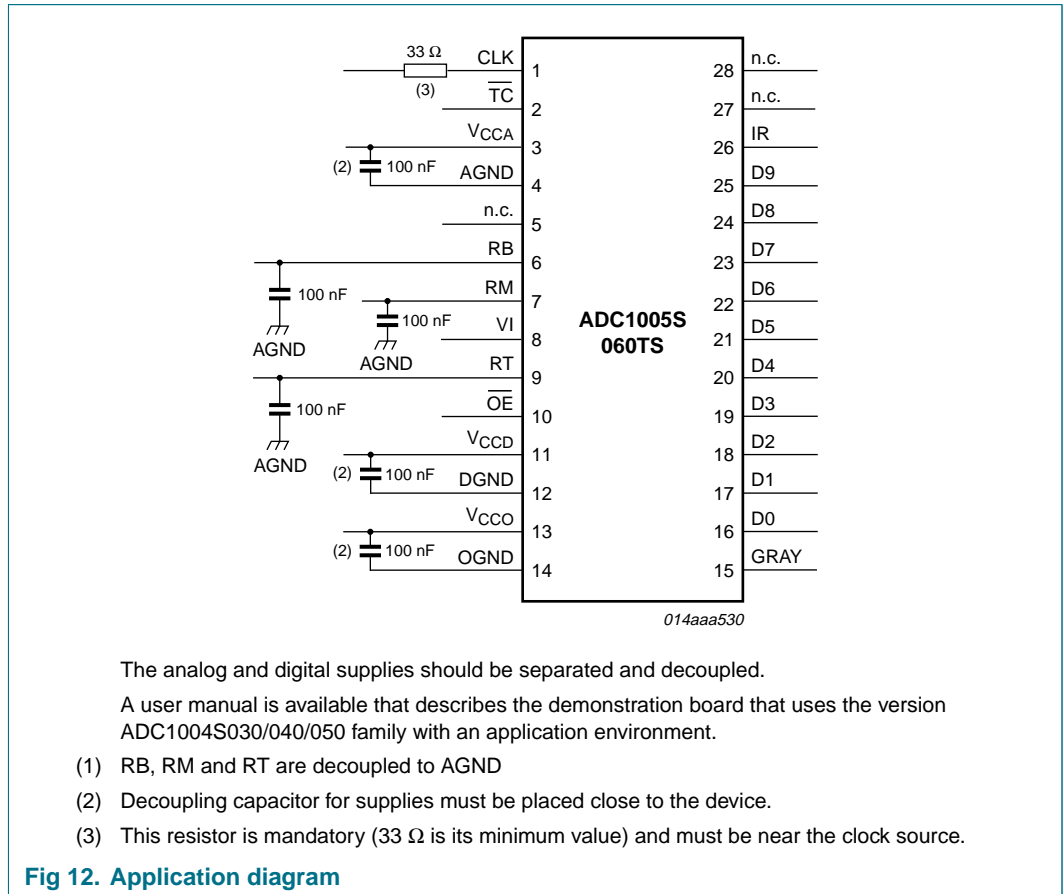

12.2 Alternative parts

The following alternative parts are also available:

Table 11. Alternative parts

Type number	Description		Sampling frequency
ADC0804S030	Single 8 bits ADC	[1]	30 MHz
ADC0804S040	Single 8 bits ADC	[1]	40 MHz
ADC0804S050	Single 8 bits ADC	[1]	50 MHz
ADC1003S030	Single 10 bits ADC, with internal reference regulator	[1]	30 MHz
ADC1003S040	Single 10 bits ADC, with internal reference regulator	[1]	40 MHz
ADC1003S050	Single 10 bits ADC, with internal reference regulator	[1]	50 MHz

Table 11. Alternative parts

Type number	Description		Sampling frequency
ADC1004S030	Single 10 bits ADC	[1]	30 MHz
ADC1004S040	Single 10 bits ADC	[1]	40 MHz
ADC1004S050	Single 10 bits ADC	[1]	50 MHz

[1] Pin to pin compatible

13. Package outline

SSOP28: plastic shrink small outline package; 28 leads; body width 5.3 mm

SOT341-1

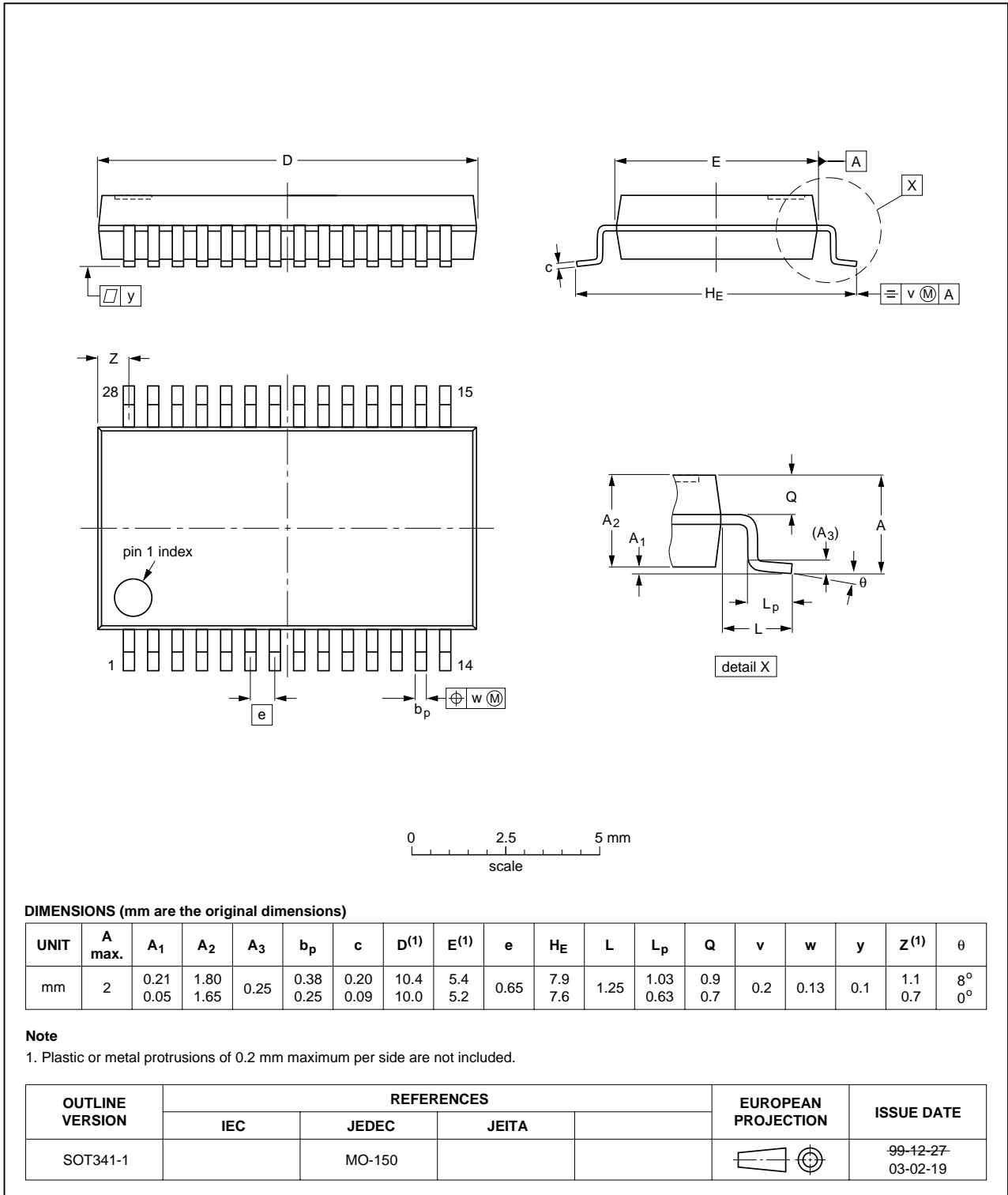

Fig 13. Package outline SOT341-1 (SSOP28)

14. Revision history

Table 12. Revision history

Document ID	Release date	Data sheet status	Change notice	Supersedes
ADC1005S060_2	20080813	Product data sheet	-	ADC1005S060_1
Modifications:		<ul style="list-style-type: none">• Corrections made to INL and DNL conditions in Table 1.• Corrections made to several entries and notes in Table 6.• Correction made to table description in Table 7.• Correction made to column D9 to D0 in Table 10.• Correction made to Figure 8.• Correction made to Figure 10.		
ADC1005S060_1	20080616	Product data sheet	-	-

15. Legal information

15.1 Data sheet status

Document status ^{[1][2]}	Product status ^[3]	Definition
Objective [short] data sheet	Development	This document contains data from the objective specification for product development.
Preliminary [short] data sheet	Qualification	This document contains data from the preliminary specification.
Product [short] data sheet	Production	This document contains the product specification.

[1] Please consult the most recently issued document before initiating or completing a design.

[2] The term 'short data sheet' is explained in section "Definitions".

[3] The product status of device(s) described in this document may have changed since this document was published and may differ in case of multiple devices. The latest product status information is available on the Internet at URL <http://www.nxp.com>.

15.2 Definitions

Draft — The document is a draft version only. The content is still under internal review and subject to formal approval, which may result in modifications or additions. NXP Semiconductors does not give any representations or warranties as to the accuracy or completeness of information included herein and shall have no liability for the consequences of use of such information.

Short data sheet — A short data sheet is an extract from a full data sheet with the same product type number(s) and title. A short data sheet is intended for quick reference only and should not be relied upon to contain detailed and full information. For detailed and full information see the relevant full data sheet, which is available on request via the local NXP Semiconductors sales office. In case of any inconsistency or conflict with the short data sheet, the full data sheet shall prevail.

15.3 Disclaimers

General — Information in this document is believed to be accurate and reliable. However, NXP Semiconductors does not give any representations or warranties, expressed or implied, as to the accuracy or completeness of such information and shall have no liability for the consequences of use of such information.

Right to make changes — NXP Semiconductors reserves the right to make changes to information published in this document, including without limitation specifications and product descriptions, at any time and without notice. This document supersedes and replaces all information supplied prior to the publication hereof.

Suitability for use — NXP Semiconductors products are not designed, authorized or warranted to be suitable for use in medical, military, aircraft, space or life support equipment, nor in applications where failure or malfunction of an NXP Semiconductors product can reasonably be expected to result in personal injury, death or severe property or environmental

damage. NXP Semiconductors accepts no liability for inclusion and/or use of NXP Semiconductors products in such equipment or applications and therefore such inclusion and/or use is at the customer's own risk.

Applications — Applications that are described herein for any of these products are for illustrative purposes only. NXP Semiconductors makes no representation or warranty that such applications will be suitable for the specified use without further testing or modification.

Limiting values — Stress above one or more limiting values (as defined in the Absolute Maximum Ratings System of IEC 60134) may cause permanent damage to the device. Limiting values are stress ratings only and operation of the device at these or any other conditions above those given in the Characteristics sections of this document is not implied. Exposure to limiting values for extended periods may affect device reliability.

Terms and conditions of sale — NXP Semiconductors products are sold subject to the general terms and conditions of commercial sale, as published at <http://www.nxp.com/profile/terms>, including those pertaining to warranty, intellectual property rights infringement and limitation of liability, unless explicitly otherwise agreed to in writing by NXP Semiconductors. In case of any inconsistency or conflict between information in this document and such terms and conditions, the latter will prevail.

No offer to sell or license — Nothing in this document may be interpreted or construed as an offer to sell products that is open for acceptance or the grant, conveyance or implication of any license under any copyrights, patents or other industrial or intellectual property rights.

Quick reference data — The Quick reference data is an extract of the product data given in the Limiting values and Characteristics sections of this document, and as such is not complete, exhaustive or legally binding.

15.4 Trademarks

Notice: All referenced brands, product names, service names and trademarks are the property of their respective owners.

16. Contact information

For more information, please visit: <http://www.nxp.com>

For sales office addresses, please send an email to: salesaddresses@nxp.com

17. Contents

1	General description	1
2	Features	1
3	Applications	1
4	Quick reference data	2
5	Ordering information	2
6	Block diagram	3
7	Pinning information	4
7.1	Pinning	4
7.2	Pin description	4
8	Limiting values	5
9	Thermal characteristics	5
10	Characteristics	6
11	Additional information relating to Table 6 ...	10
12	Application information	14
12.1	Application diagrams	14
12.2	Alternative parts	14
13	Package outline	16
14	Revision history	17
15	Legal information	18
15.1	Data sheet status	18
15.2	Definitions	18
15.3	Disclaimers	18
15.4	Trademarks	18
16	Contact information	18
17	Contents	19



Please be aware that important notices concerning this document and the product(s) described herein, have been included in section 'Legal information'.

© NXP B.V. 2008.

All rights reserved.

For more information, please visit: <http://www.nxp.com>

For sales office addresses, please send an email to: salesaddresses@nxp.com

Date of release: 13 August 2008

Document identifier: ADC1005S060_2