

ADC1413D series

Dual 14-bit ADC; 65 Msps, 80 Msps, 105 Msps or 125 Msps;
serial JESD204A interface

Rev. 6 — 8 June 2011

Product data sheet

1. General description

The ADC1413D is a dual-channel 14-bit Analog-to-Digital Converter (ADC) optimized for high dynamic performance and low power at sample rates up to 125 Msps. Pipelined architecture and output error correction ensure the ADC1413D is accurate enough to guarantee zero missing codes over the entire operating range. Supplied from a 3 V source for analog and a 1.8 V source for the output driver, it embeds two serial outputs. Each lane is differential and complies with the JESD204A standard. An integrated Serial Peripheral Interface (SPI) allows the user to easily configure the ADCs. A set of IC configurations is also available via the binary level control pins taken, which are used at power-up. The device also includes a programmable full-scale SPI to allow a flexible input voltage range of 1 V to 2 V (peak-to-peak).

Excellent dynamic performance is maintained from the baseband to input frequencies of 170 MHz or more, making the ADC1413D ideal for use in communications, imaging, and medical applications.

2. Features and benefits

- SNR, 72 dBFS; SFDR, 86 dBc
- Sample rate up to 125 Msps
- Clock input divided by 2 for less jitter contribution
- 3 V, 1.8 V power supplies
- Flexible input voltage range: 1 V (p-p) to 2 V (p-p)
- Two configurable serial outputs
- Compliant with JESD204A serial transmission standard
- Pin compatible with the ADC1613D series, ADC1213D series, and ADC1113D125
- Input bandwidth, 600 MHz
- Power dissipation, 995 mW at 80 Msps
- SPI register programming
- Duty cycle stabilizer (DCS)
- High IF capability
- Offset binary, two's complement, gray code
- Power-down mode and Sleep mode
- HVQFN56 package



3. Applications

- Wireless and wired broadband communications
- Spectral analysis
- Ultrasound equipment
- Portable instrumentation
- Imaging systems
- Software defined radio

4. Ordering information

Table 1. Ordering information

Type number	Sampling frequency (MSPS)	Package		
		Name	Description	Version
ADC1413D125HN/C1	125	HVQFN56	plastic thermal enhanced very thin quad flat package; no leads; 56 terminals; body 8 × 8 × 0.85 mm	SOT684-7
ADC1413D105HN/C1	105	HVQFN56	plastic thermal enhanced very thin quad flat package; no leads; 56 terminals; body 8 × 8 × 0.85 mm	SOT684-7
ADC1413D080HN/C1	80	HVQFN56	plastic thermal enhanced very thin quad flat package; no leads; 56 terminals; body 8 × 8 × 0.85 mm	SOT684-7
ADC1413D065HN/C1	65	HVQFN56	plastic thermal enhanced very thin quad flat package; no leads; 56 terminals; body 8 × 8 × 0.85 mm	SOT684-7

5. Block diagram

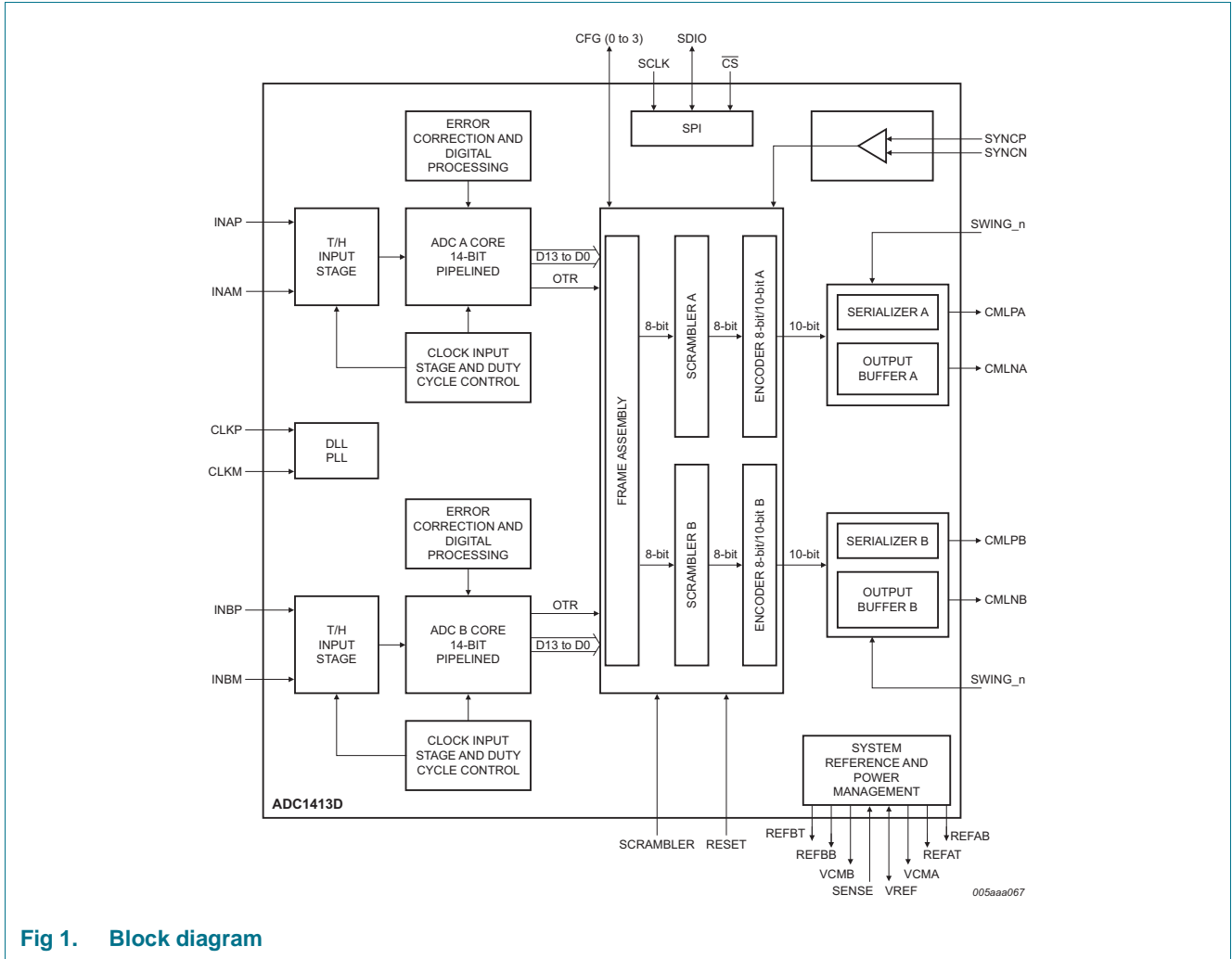

Fig 1. Block diagram

6. Pinning information

6.1 Pinning

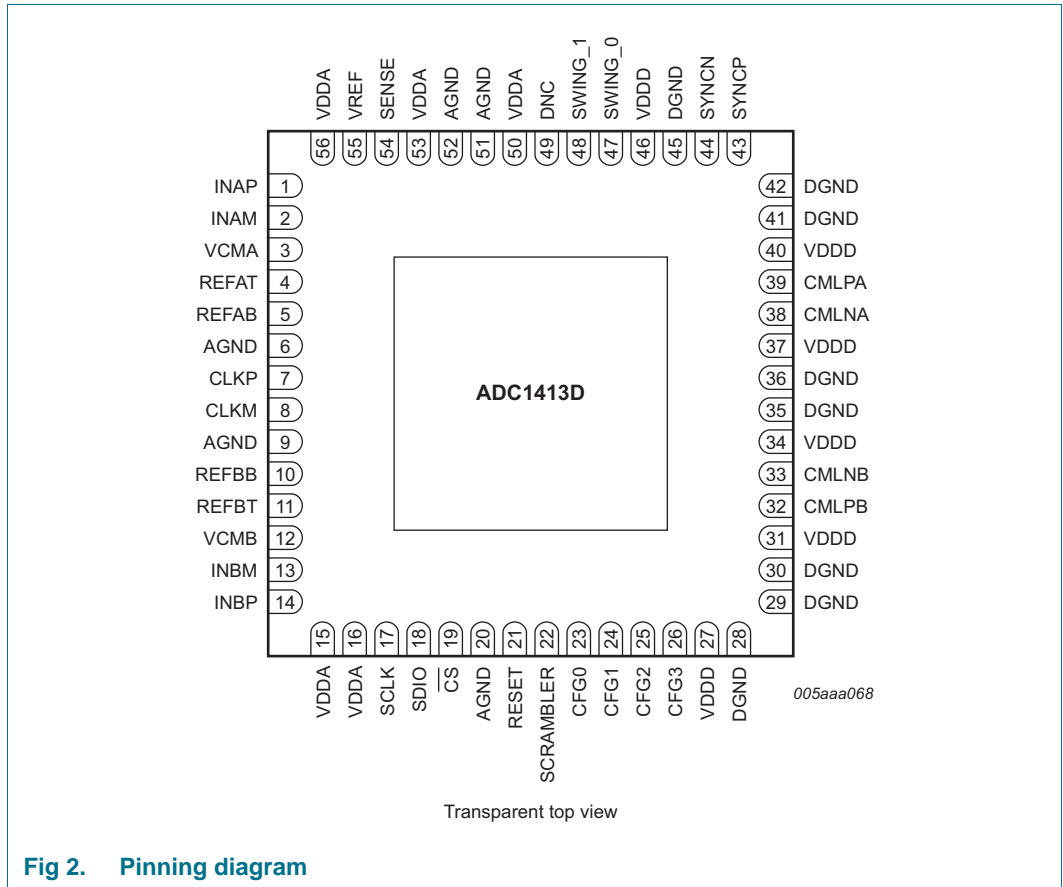

Fig 2. Pinning diagram

6.2 Pin description

Table 2. Pin description

Symbol	Pin	Type ^[1]	Description
INAP	1	I	channel A analog input
INAM	2	I	channel A complementary analog input
VCMA	3	O	channel A output common voltage
REFAT	4	O	channel A top reference
REFAB	5	O	channel A bottom reference
AGND	6	G	analog ground
CLKP	7	I	clock input
CLKM	8	I	complementary clock input
AGND	9	G	analog ground
REFBB	10	O	channel B bottom reference
REFBT	11	O	channel B top reference
VCMB	12	O	channel B output common voltage
INBM	13	I	channel B complementary analog input

Table 2. Pin description ...continued

Symbol	Pin	Type ^[1]	Description
INBP	14	I	channel B analog input
VDDA	15	P	analog power supply 3 V
VDDA	16	P	analog power supply 3 V
SCLK	17	I	SPI clock
SDIO	18	I/O	SPI data input/output
$\overline{\text{CS}}$	19	I	chip select
AGND	20	G	analog ground
RESET	21	I	JEDEC digital IP reset
SCRAMBLER	22	I	scrambler enable and disable
CFG0	23	I/O	See Table 28 (input) or OTRA (output) ^[2]
CFG1	24	I/O	See Table 28 (input) or OTRB (output) ^[2]
CFG2	25	I/O	See Table 28 (input)
CFG3	26	I/O	See Table 28 (input)
VDDD	27	P	digital power supply 1.8 V
DGND	28	G	digital ground
DGND	29	G	digital ground
DGND	30	G	digital ground
VDDD	31	P	digital power supply 1.8 V
CMLPB	32	O	channel B output
CMLNB	33	O	channel B complementary output
VDDD	34	P	digital power supply 1.8 V
DGND	35	G	digital ground
DGND	36	G	digital ground
VDDD	37	P	digital power supply 1.8 V
CMLNA	38	O	channel A complementary output
CMLPA	39	O	channel A output
VDDD	40	P	digital power supply 1.8 V
DGND	41	G	digital ground
DGND	42	G	digital ground
SYNCP	43	I	synchronization from FPGA
SYNCP	44	I	synchronization from FPGA
DGND	45	G	digital ground
VDDD	46	P	digital power supply 1.8 V
SWING_0	47	I	JESD204 serial buffer programmable output swing
SWING_1	48	I	JESD204 serial buffer programmable output swing
DNC	49	O	do not connect
VDDA	50	P	analog power supply 3 V
AGND	51	G	analog ground
AGND	52	G	analog ground

Table 2. Pin description ...continued

Symbol	Pin	Type ^[1]	Description
VDDA	53	P	analog power supply 3 V
SENSE	54	I	reference programming pin
VREF	55	I/O	voltage reference input/output
VDDA	56	P	analog power supply 3 V

[1] P: power supply; G: ground; I: input; O: output; I/O: input/output.

[2] OTRA stands for "OuT of Range A". OTRB stands for "OuT of Range B"

7. Limiting values

Table 3. Limiting values

In accordance with the Absolute Maximum Rating System (IEC 60134).

Symbol	Parameter	Conditions	Min	Max	Unit
V _{DDA}	analog supply voltage		-0.4	+4.6	V
V _{DDD}	digital supply voltage		-0.4	+2.5	V
T _{stg}	storage temperature		-55	+125	°C
T _{amb}	ambient temperature		-40	+85	°C
T _j	junction temperature		-	125	°C

8. Thermal characteristics

Table 4. Thermal characteristics

Symbol	Parameter	Conditions	Typ	Unit
R _{th(j-a)}	thermal resistance from junction to ambient		^[1] 17.8	K/W
R _{th(j-c)}	thermal resistance from junction to case		^[1] 6.8	K/W

[1] Value for six layers board in still air with a minimum of 25 thermal vias.

9. Static characteristics

Table 5. Static characteristics^[1]

Symbol	Parameter	Conditions	Min	Typ	Max	Unit
Supplies						
V_{DDA}	analog supply voltage		2.85	3.0	3.4	V
V_{DDD}	digital supply voltage		1.65	1.8	1.95	V
I_{DDA}	analog supply current	$f_{clk} = 125$ Msps; $f_i = 70$ MHz	-	343	-	mA
I_{DDD}	digital supply current	$f_{clk} = 125$ Msps; $f_i = 70$ MHz	-	150	-	mA
P_{tot}	total power dissipation	$f_{clk} = 125$ Msps	-	1270	-	mW
		$f_{clk} = 105$ Msps	-	1150	-	mW
		$f_{clk} = 80$ Msps	-	995	-	mW
		$f_{clk} = 65$ Msps	-	885	-	mW
P	power dissipation	Power-down mode	-	30	-	mW
		Standby mode	-	200	-	mW
Clock inputs: pins CLKP and CLKM (AC-coupled)						
Low-Voltage Positive Emitter-Coupled Logic (LVPECL)						
$V_{i(clk)dif}$	differential clock input voltage	peak-to-peak	-	1.6	-	V
SINE						
$V_{i(clk)dif}$	differential clock input voltage	peak	-	± 3.0	-	V
Low Voltage Complementary Metal Oxide Semiconductor (LVCMOS)						
V_{IL}	LOW-level input voltage		-	-	$0.3V_{DDA}$	V
V_{IH}	HIGH-level input voltage		$0.7V_{DDA}$	-	-	V
Logic inputs: Power-down: pins CFG0 to CFG3, SCRAMBLER, SWING_0, SWING_1, and RESET						
V_{IL}	LOW-level input voltage		-	0	-	V
V_{IH}	HIGH-level input voltage		-	$0.66V_{DDD}$	-	V
I_{IL}	LOW-level input current		-6	-	+6	μA
I_{IH}	HIGH-level input current		-30	-	+30	μA
SPI: pins \overline{CS}, SDIO, and SCLK						
V_{IL}	LOW-level input voltage		0	-	$0.3V_{DDA}$	V
V_{IH}	HIGH-level input voltage		$0.7V_{DDA}$	-	V_{DDA}	V
I_{IL}	LOW-level input current		-10	-	+10	μA
I_{IH}	HIGH-level input current		-50	-	+50	μA
C_i	input capacitance		-	4	-	pF
Analog inputs: pins INAP, INAM, INBP, and INBM						
I_i	input current	track mode	-5	-	+5	μA
R_i	input resistance	track mode	-	15	-	Ω
C_i	input capacitance	track mode	-	5	-	pF
$V_{I(cm)}$	common-mode input voltage	track mode	0.9	1.5	2	V

Table 5. Static characteristics^[1] ...continued

Symbol	Parameter	Conditions	Min	Typ	Max	Unit
B_i	input bandwidth		-	600	-	MHz
$V_{I(dif)}$	differential input voltage	peak-to-peak	1	-	2	V
Voltage controlled regulator output: pins VCMA and VCMB						
$V_{O(cm)}$	common-mode output voltage		-	$V_{DDA} / 2$	-	V
$I_{O(cm)}$	common-mode output current		-	4	-	mA
Reference voltage input/output: pin VREF						
V_{VREF}	voltage on pin VREF	output	0.5	-	1	V
		input	0.5	-	1	V
Data outputs: pins CMLPA, CMLNA						
Output levels, $V_{DDD} = 1.8\text{ V}$; $SWING_SEL[2:0] = 000$						
V_{OL}	LOW-level output voltage	DC coupled; output	-	1.5	-	V
		AC coupled	-	1.35	-	V
V_{OH}	HIGH-level output voltage	DC coupled; output	-	1.8	-	V
		AC coupled	-	1.65	-	V
Output levels, $V_{DDD} = 1.8\text{ V}$; $SWING_SEL[2:0] = 001$						
V_{OL}	LOW-level output voltage	DC coupled; output	-	1.45	-	V
		AC coupled	-	1.275	-	V
V_{OH}	HIGH-level output voltage	DC coupled; output	-	1.8	-	V
		AC coupled	-	1.625	-	V
Output levels, $V_{DDD} = 1.8\text{ V}$; $SWING_SEL[2:0] = 010$						
V_{OL}	LOW-level output voltage	DC coupled; output	-	1.4	-	V
		AC coupled	-	1.2	-	V
V_{OH}	HIGH-level output voltage	DC coupled; output	-	1.8	-	V
		AC coupled	-	1.6	-	V
Output levels, $V_{DDD} = 1.8\text{ V}$; $SWING_SEL[2:0] = 011$						
V_{OL}	LOW-level output voltage	DC coupled; output	-	1.35	-	V
		AC coupled	-	1.125	-	V
V_{OH}	HIGH-level output voltage	DC coupled; output	-	1.8	-	V
		AC coupled	-	1.575	-	V
Output levels, $V_{DDD} = 1.8\text{ V}$; $SWING_SEL[2:0] = 100$						
V_{OL}	LOW-level output voltage	DC coupled; output	-	1.3	-	V
		AC coupled	-	1.05	-	V
V_{OH}	HIGH-level output voltage	DC coupled; output	-	1.8	-	V
		AC coupled	-	1.55	-	V
Serial configuration: pins SYNCPP, SYNCNN						
V_{IL}	LOW-level input voltage	differential; input	-	0.95	-	V
V_{IH}	HIGH-level input voltage	differential; input	-	1.47	-	V
Accuracy						
INL	integral non-linearity		-	± 5	-	LSB

Table 5. Static characteristics^[1] ...continued

Symbol	Parameter	Conditions	Min	Typ	Max	Unit
DNL	differential non-linearity	guaranteed no missing codes	-0.95	±0.5	+0.95	LSB
E _{offset}	offset error		-	±2	-	mV
E _G	gain error	full-scale	-	± 0.5	-	%
M _{G(CTC)}	channel-to-channel gain matching		-	1.1	-	%
Supply						
PSRR	power supply rejection ratio	200 mV (p-p) on pin VDDA; f _i = DC	-	-54	-	dB

[1] Typical values measured at V_{DDA} = 3 V, V_{DDD} = 1.8 V, T_{amb} = 25 °C. Minimum and maximum values are across the full temperature range T_{amb} = -40 °C to +85 °C at V_{DDA} = 3 V, V_{DDD} = 1.8 V; V_I (INAP, INBP) – V_I (INAM, INBM) = -1 dBFS; internal reference mode; 100 Ω differential applied to serial outputs; unless otherwise specified.

10. Dynamic characteristics

10.1 Dynamic characteristics

Table 6. Dynamic characteristics^[1]

Symbol	Parameter	Conditions	ADC1413D065			ADC1413D080			ADC1413D105			ADC1413D125			Unit
			Min	Typ	Max	Min	Typ	Max	Min	Typ	Max	Min	Typ	Max	
Analog signal processing															
α_{2H}	second harmonic level	$f_i = 3$ MHz	-	87	-	-	87	-	-	86	-	-	88	-	dBc
		$f_i = 30$ MHz	-	86	-	-	86	-	-	86	-	-	87	-	dBc
		$f_i = 70$ MHz	-	85	-	-	85	-	-	84	-	-	85	-	dBc
		$f_i = 170$ MHz	-	82	-	-	82	-	-	81	-	-	83	-	dBc
α_{3H}	third harmonic level	$f_i = 3$ MHz	-	86	-	-	86	-	-	85	-	-	87	-	dBc
		$f_i = 30$ MHz	-	85	-	-	85	-	-	85	-	-	86	-	dBc
		$f_i = 70$ MHz	-	84	-	-	84	-	-	83	-	-	84	-	dBc
		$f_i = 170$ MHz	-	81	-	-	81	-	-	80	-	-	82	-	dBc
THD	total harmonic distortion	$f_i = 3$ MHz	-	83	-	-	83	-	-	82	-	-	84	-	dBc
		$f_i = 30$ MHz	-	82	-	-	82	-	-	82	-	-	83	-	dBc
		$f_i = 70$ MHz	-	81	-	-	81	-	-	80	-	-	81	-	dBc
		$f_i = 170$ MHz	-	78	-	-	78	-	-	77	-	-	79	-	dBc
ENOB	effective number of bits	$f_i = 3$ MHz	-	11.7	-	-	11.7	-	-	11.6	-	-	11.6	-	bits
		$f_i = 30$ MHz	-	11.6	-	-	11.5	-	-	11.5	-	-	11.5	-	bits
		$f_i = 70$ MHz	-	11.5	-	-	11.5	-	-	11.4	-	-	11.4	-	bits
		$f_i = 170$ MHz	-	11.4	-	-	11.4	-	-	11.3	-	-	11.3	-	bits
SNR	signal-to-noise ratio	$f_i = 3$ MHz	-	72.1	-	-	72.0	-	-	71.8	-	-	71.4	-	dBFS
		$f_i = 30$ MHz	-	71.3	-	-	71.2	-	-	71.2	-	-	71.1	-	dBFS
		$f_i = 70$ MHz	-	70.7	-	-	70.7	-	-	70.6	-	-	70.5	-	dBFS
		$f_i = 170$ MHz	-	70.2	-	-	70.1	-	-	70.0	-	-	69.9	-	dBFS
SFDR	spurious-free dynamic range	$f_i = 3$ MHz	-	86	-	-	86	-	-	85	-	-	87	-	dBc
		$f_i = 30$ MHz	-	85	-	-	85	-	-	85	-	-	86	-	dBc
		$f_i = 70$ MHz	-	84	-	-	84	-	-	83	-	-	84	-	dBc
		$f_i = 170$ MHz	-	81	-	-	81	-	-	80	-	-	82	-	dBc

Table 6. Dynamic characteristics^[1] ...continued

Symbol	Parameter	Conditions	ADC1413D065			ADC1413D080			ADC1413D105			ADC1413D125			Unit
			Min	Typ	Max	Min	Typ	Max	Min	Typ	Max	Min	Typ	Max	
IMD	intermodulation distortion	$f_i = 3 \text{ MHz}$	-	89	-	-	89	-	-	88	-	-	89	-	dBc
		$f_i = 30 \text{ MHz}$	-	88	-	-	88	-	-	88	-	-	88	-	dBc
		$f_i = 70 \text{ MHz}$	-	87	-	-	87	-	-	86	-	-	86	-	dBc
		$f_i = 170 \text{ MHz}$	-	84	-	-	85	-	-	83	-	-	84	-	dBc
$\alpha_{ct(ch)}$	channel crosstalk	$f_i = 70 \text{ MHz}$	-	100	-	-	100	-	-	100	-	-	100	-	dBc

[1] Typical values measured at $V_{DDA} = 3 \text{ V}$, $V_{DDD} = 1.8 \text{ V}$, $T_{amb} = 25 \text{ }^\circ\text{C}$. Minimum and maximum values are across the full temperature range $T_{amb} = -40 \text{ }^\circ\text{C}$ to $+85 \text{ }^\circ\text{C}$ at $V_{DDA} = 3 \text{ V}$, $V_{DDD} = 1.8 \text{ V}$; V_I (INAP, INBP) – V_I (INAM, INBM) = -1 dBFS; internal reference mode; 100 Ω differential applied to serial outputs; unless otherwise specified.

10.2 Clock and digital output timing

Table 7. Clock and digital output characteristics^[1]

Symbol	Parameter	Conditions	ADC1413D065			ADC1413D080			ADC1413D105			ADC1413D125			Unit
			Min	Typ	Max	Min	Typ	Max	Min	Typ	Max	Min	Typ	Max	
Clock timing input: pins CLKP and CLKM															
f_{clk}	clock frequency		45	-	65	60	-	80	75	-	105	100	-	125	Msp/s
$t_{lat(data)}$	data latency time	clock cycles	307	-	850	250	-	283	190	-	226	160	-	170	ns
δ_{clk}	clock duty cycle	DCS_EN = logic 1	30	50	70	30	50	70	30	50	70	30	50	70	%
$t_{d(s)}$	sampling delay time		-	0.8	-	-	0.8	-	-	0.8	-	-	0.8	-	ns
t_{wake}	wake-up time		-	76	-	-	76	-	-	76	-	-	76	-	μs

[1] Typical values measured at $V_{DDA} = 3 \text{ V}$, $V_{DDD} = 1.8 \text{ V}$, $T_{amb} = 25 \text{ }^\circ\text{C}$. Minimum and maximum values are across the full temperature range $T_{amb} = -40 \text{ }^\circ\text{C}$ to $+85 \text{ }^\circ\text{C}$ at $V_{DDA} = 3 \text{ V}$, $V_{DDD} = 1.8 \text{ V}$; V_I (INAP, INBP) – V_I (INAM, INBM) = -1 dBFS; internal reference mode; 100 Ω differential applied to serial outputs; unless otherwise specified.

10.3 Serial output timing

The eye diagram of the serial output is shown in [Figure 3](#) and [Figure 4](#). Test conditions are:

- 3.125 Gbps data rate
- $T_{amb} = 25\text{ }^{\circ}\text{C}$
- DC coupling with two different receiver common-mode voltages

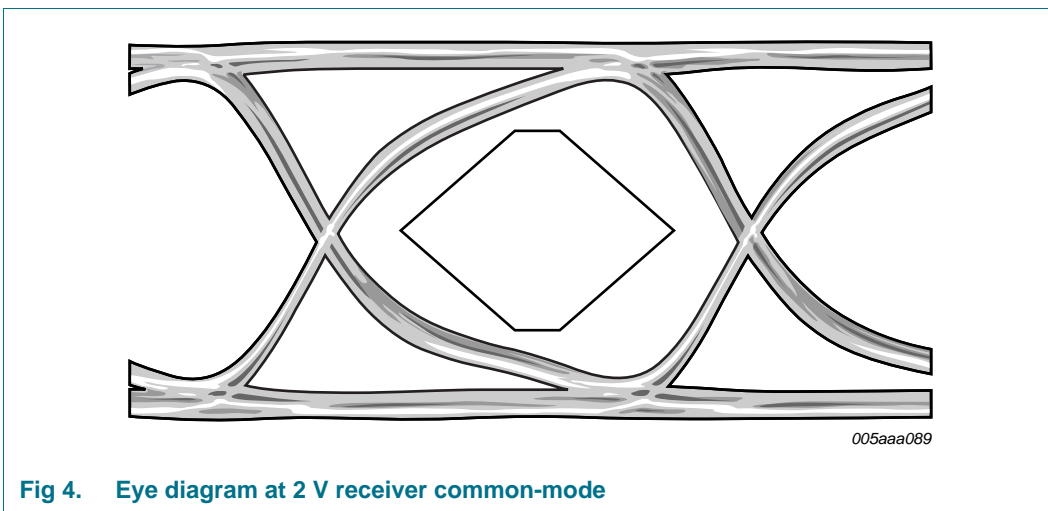
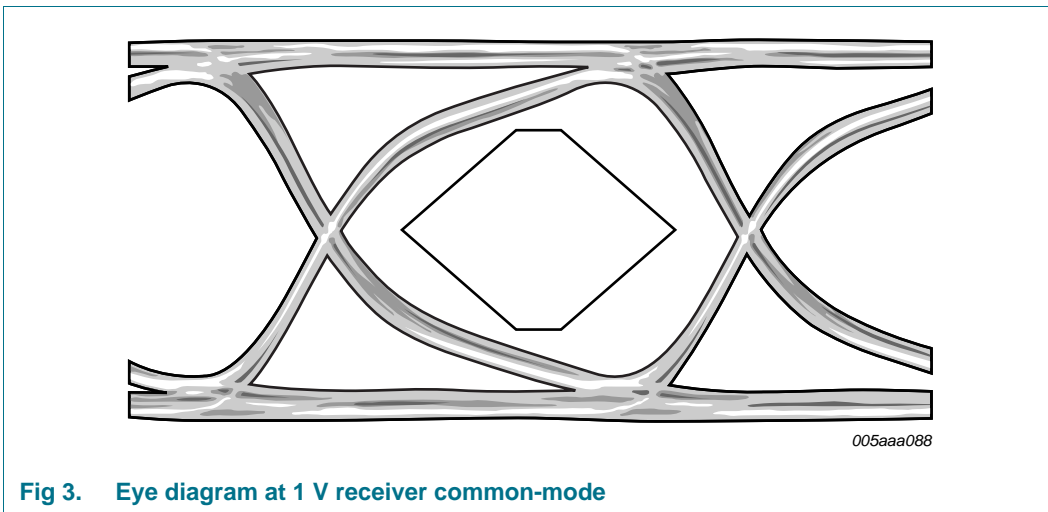

10.4 SPI timing

Table 8. SPI timing characteristics^[1]

Symbol	Parameter	Conditions	Min	Typ	Max	Unit
$t_{w(SCLK)}$	SCLK pulse width		-	40	-	ns
$t_{w(SCLKH)}$	SCLK HIGH pulse width		-	16	-	ns
$t_{w(SCLKL)}$	SCLK LOW pulse width		-	16	-	ns
t_{su}	set-up time	data to SCLKH	-	5	-	ns
		\overline{CS} to SCLKH	-	5	-	ns
t_h	hold time	data to SCLKH	-	2	-	ns
		\overline{CS} to SCLKH	-	2	-	ns
$f_{clk(max)}$	maximum clock frequency		-	25	-	MHz

[1] Typical values measured at $V_{DDA} = 3\text{ V}$, $V_{DDD} = 1.8\text{ V}$, $T_{amb} = 25\text{ }^\circ\text{C}$. Minimum and maximum values are across the full temperature range $T_{amb} = -40\text{ }^\circ\text{C}$ to $+85\text{ }^\circ\text{C}$ at $V_{DDA} = 3\text{ V}$, $V_{DDD} = 1.8\text{ V}$; V_I (INAP, INBP) – V_I (INAM, INBM) = -1 dBFS; internal reference mode; 100 Ω differential applied to serial outputs; unless otherwise specified.

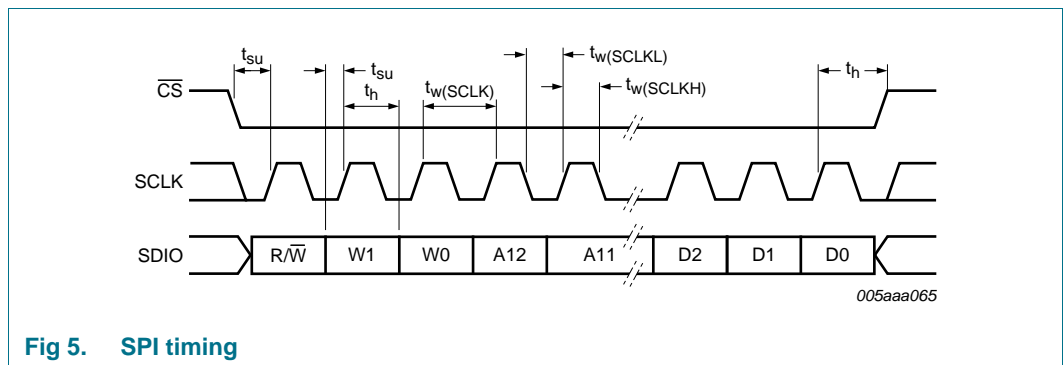

Fig 5. SPI timing

11. Application information

11.1 Analog inputs

11.1.1 Input stage description

The analog input of the ADC1413D supports a differential or a single-ended input drive. Optimal performance is achieved using differential inputs with the common-mode input voltage ($V_{I(cm)}$) on pins INxP and INxM set to $0.5V_{DDA}$.

The full-scale analog input voltage range is configurable between 1 V (p-p) and 2 V (p-p) via a programmable internal reference (see [Section 11.2](#) and [Table 21](#)).

[Figure 6](#) shows the equivalent circuit of the sample-and-hold input stage, including ElectroStatic Discharge (ESD) protection and circuit and package parasitics.

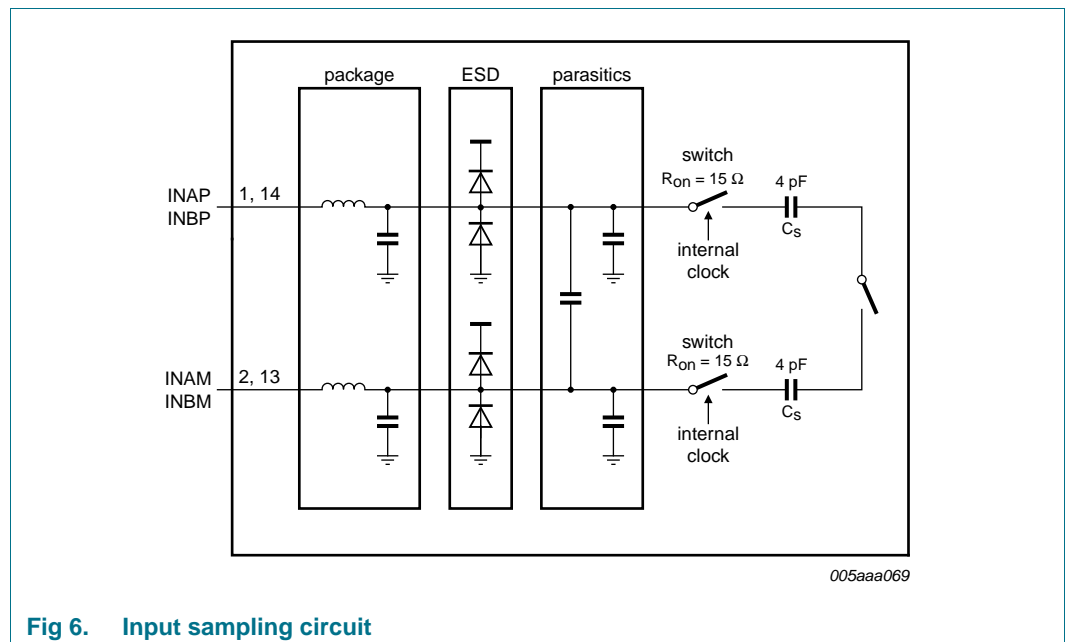

Fig 6. Input sampling circuit

The sample phase occurs when the internal clock (derived from the clock signal on pin CLKP/CLKM) is HIGH. The voltage is then held on the sampling capacitors. When the clock signal goes LOW, the stage enters the hold phase and the voltage information is transmitted to the ADC core.

11.1.2 Anti-kickback circuitry

Anti-kickback circuitry (RC filter in Figure 7) is needed to counteract the effects of a charge injection generated by the sampling capacitance.

The RC filter is also used to filter noise from the signal before it reaches the sampling stage. The value of the capacitor should be chosen to maximize noise attenuation without degrading the settling time excessively.

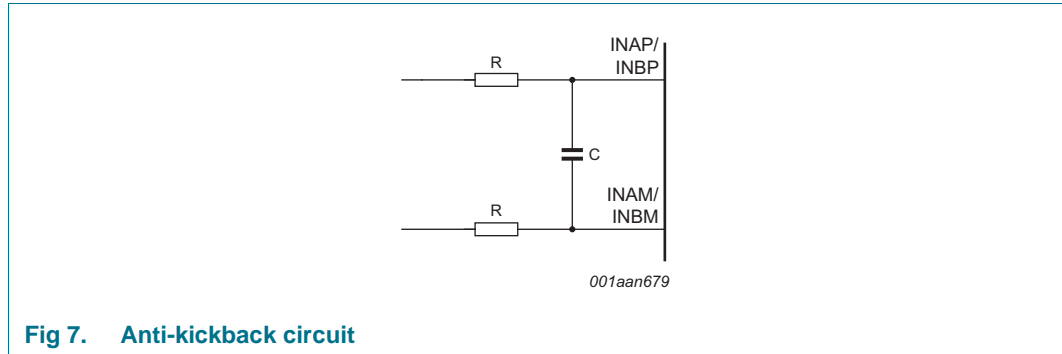

Fig 7. Anti-kickback circuit

The component values are determined by the input frequency and should be selected so as not to affect the input bandwidth.

Table 9. RC coupling versus input frequency, typical values

Input frequency (MHz)	Resistance (Ω)	Capacitance (pF)
3	25	12
70	12	8
170	12	8

11.1.3 Transformer

The configuration of the transformer circuit is determined by the input frequency. The configuration shown in Figure 8 would be suitable for a baseband application.

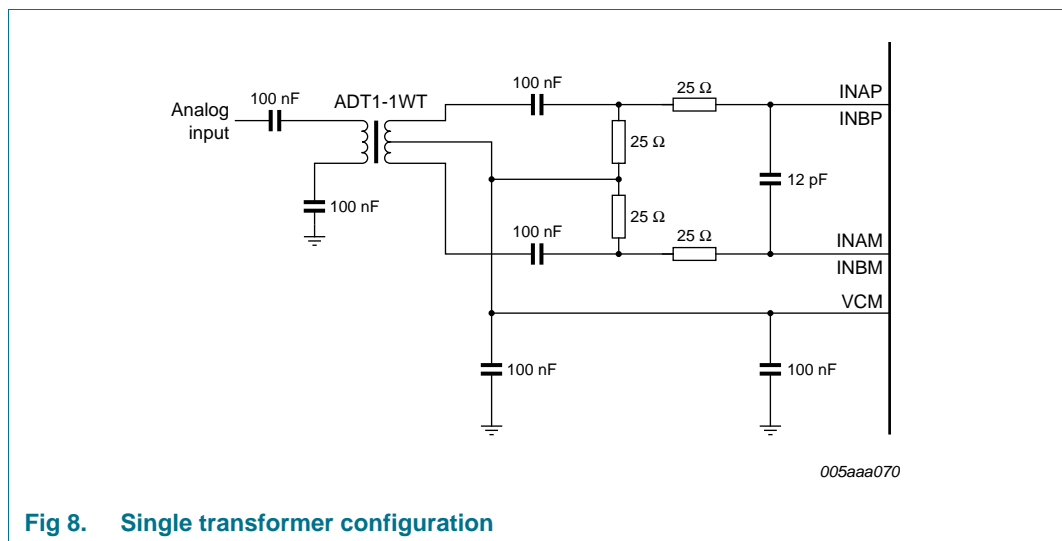

Fig 8. Single transformer configuration

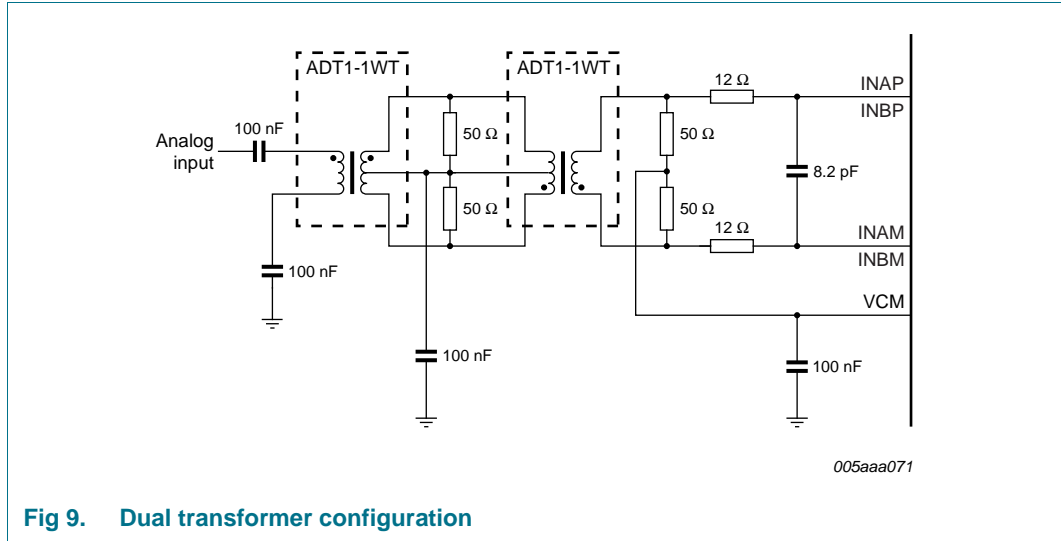

Fig 9. Dual transformer configuration

The configuration shown in [Figure 9](#) is recommended for high frequency applications. In both cases, the choice of transformer is a compromise between cost and performance.

11.2 System reference and power management

11.2.1 Internal/external reference

The ADC1413D has a stable and accurate built-in internal reference voltage to adjust the ADC full-scale. This reference voltage can be set internally via SPI or with pins VREF and SENSE (see [Figure 11](#) to [Figure 14](#)), in 1 dB steps between 0 dB and -6 dB, via SPI control bits INTREF[2:0] (when bit INTREF_EN = logic 1; see [Table 21](#)). The equivalent reference circuit is shown in [Figure 10](#). An external reference is also possible by providing a voltage on pin VREF as described in [Figure 13](#).

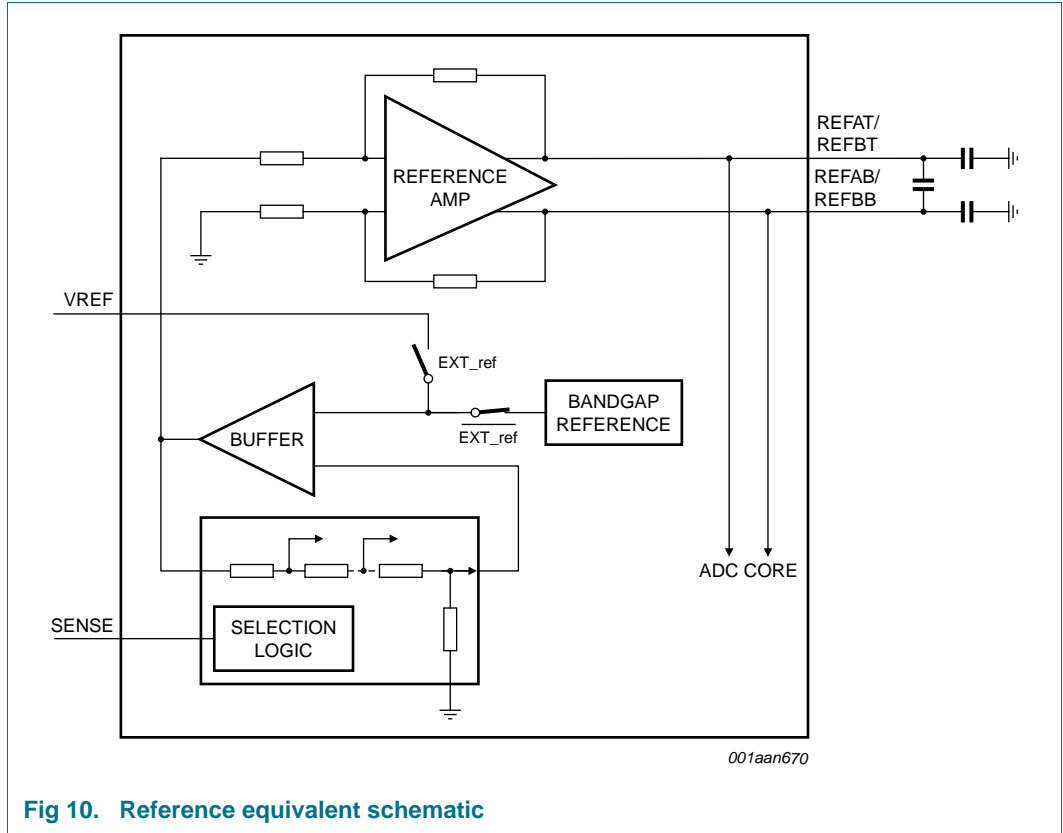

Fig 10. Reference equivalent schematic

If bit INTREF_EN is set to logic 0, the reference voltage is determined either internally or externally as detailed in [Table 10](#).

Table 10. Reference modes

Mode	SPI bit, "Internal reference"	SENSE pin	VREF pin	Full-scale (V (p-p))
Internal (Figure 11)	0	GND	330 pF capacitor to GND	2
Internal (Figure 12)	0	VREF pin = SENSE pin and 330 pF capacitor to GND		1
External (Figure 13)	0	V _{DDA}	external voltage from 0.5 V to 1 V	1 to 2
Internal, SPI mode (Figure 14)	1	VREF pin = SENSE pin and 330 pF capacitor to GND		1 to 2

[Figure 11](#) to [Figure 14](#) illustrate how to connect the SENSE and VREF pins to select the required reference voltage source.

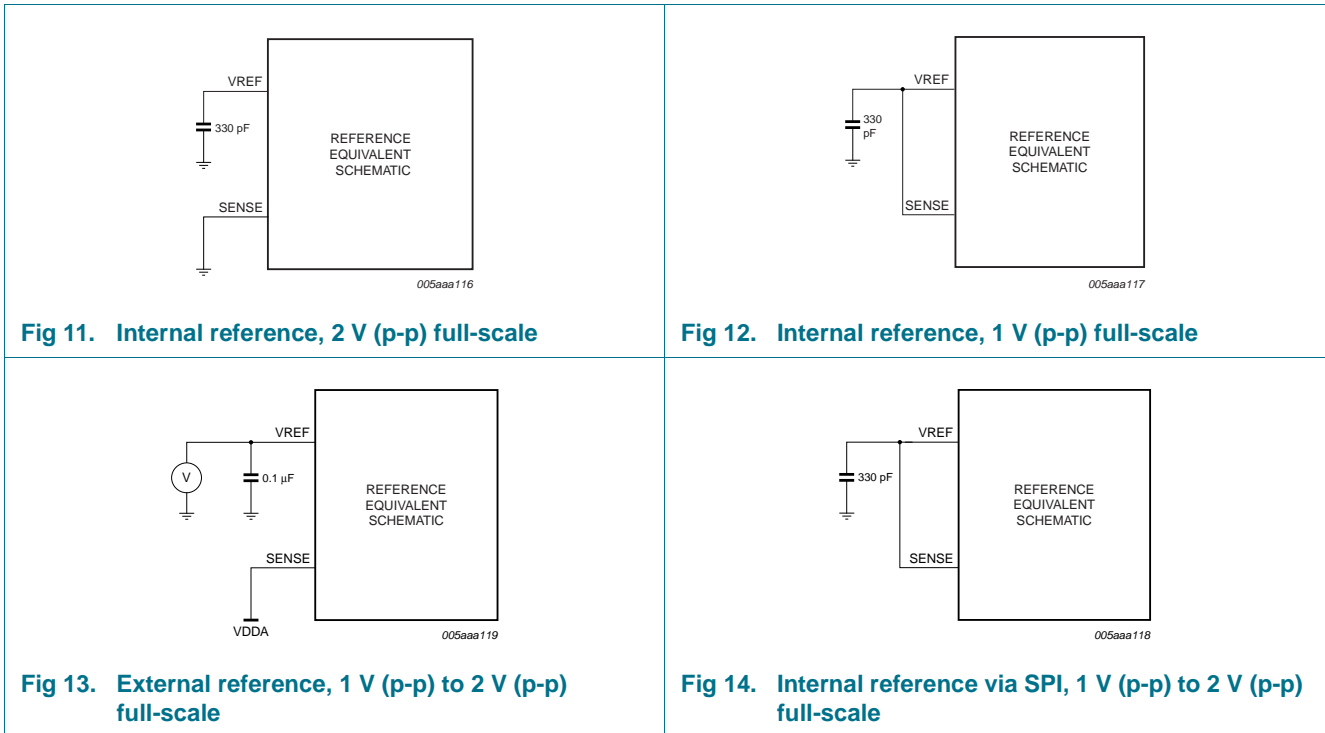

11.2.2 Programmable full-scale

The full-scale is programmable between 1 V (p-p) to 2 V (p-p) (see [Table 11](#)).

Table 11. Programmable full-scale

INTREF[2:0]	Level (dB)	Full-scale (V (p-p))
000	0	2
001	-1	1.78
010	-2	1.59
011	-3	1.42
100	-4	1.26
101	-5	1.12
110	-6	1
111	not used	x

11.2.3 Common-mode output voltage ($V_{O(cm)}$)

An 0.1 μ F filter capacitor should be connected between pins VCMA and VCMB and ground to ensure a low-noise common-mode output voltage. When AC-coupled, these pins can be used to set the common-mode reference for the analog inputs, for instance via a transformer middle point.

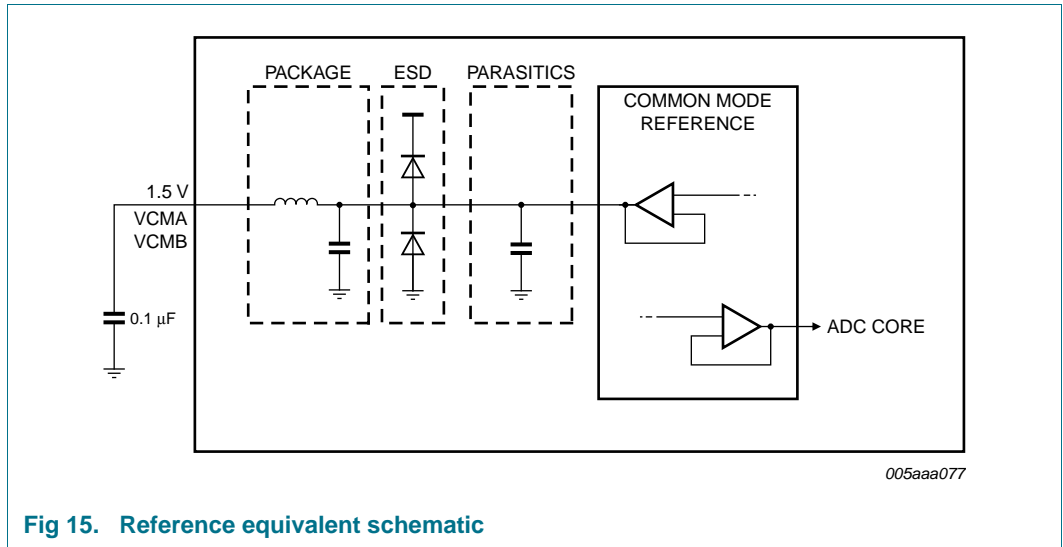

Fig 15. Reference equivalent schematic

11.2.4 Biasing

The common-mode input voltage, $V_{I(cm)}$, at the inputs to the sample-and-hold stage (pins INAM, INBM, INAP, and INBP) must be between 0.9 V and 2 V for optimal performance.

11.3 Clock input

11.3.1 Drive modes

The ADC1413D can be driven differentially (LVPECL). It can also be driven by a single-ended Low Voltage Complementary Metal Oxide Semiconductor (LVCMOS) signal connected to pin CLKP (pin CLKM should be connected to ground via a capacitor) or pin CLKM (pin CLKP should be connected to ground via a capacitor).

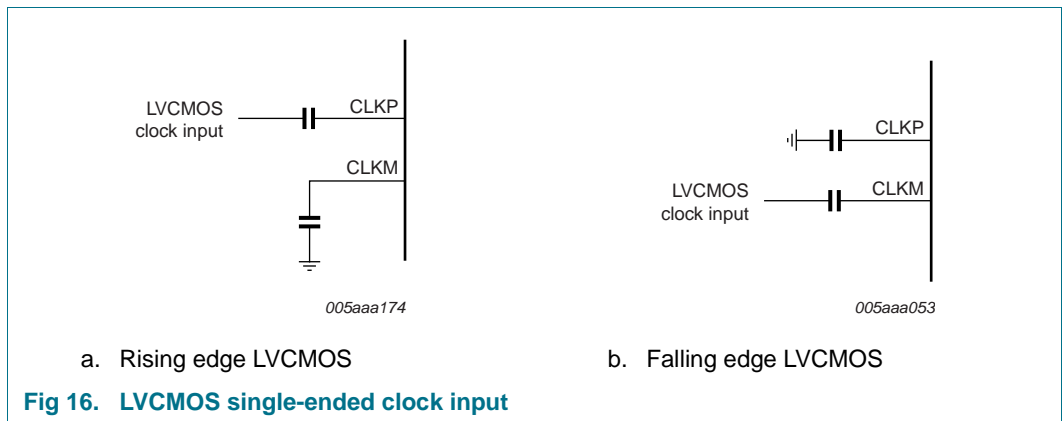
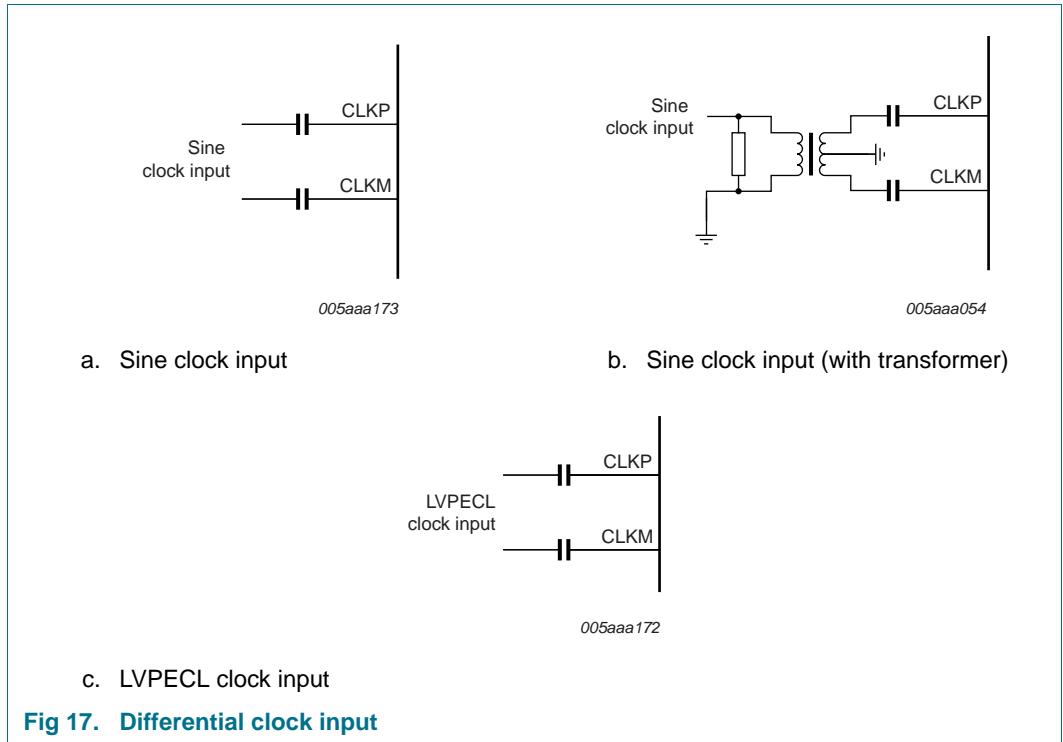
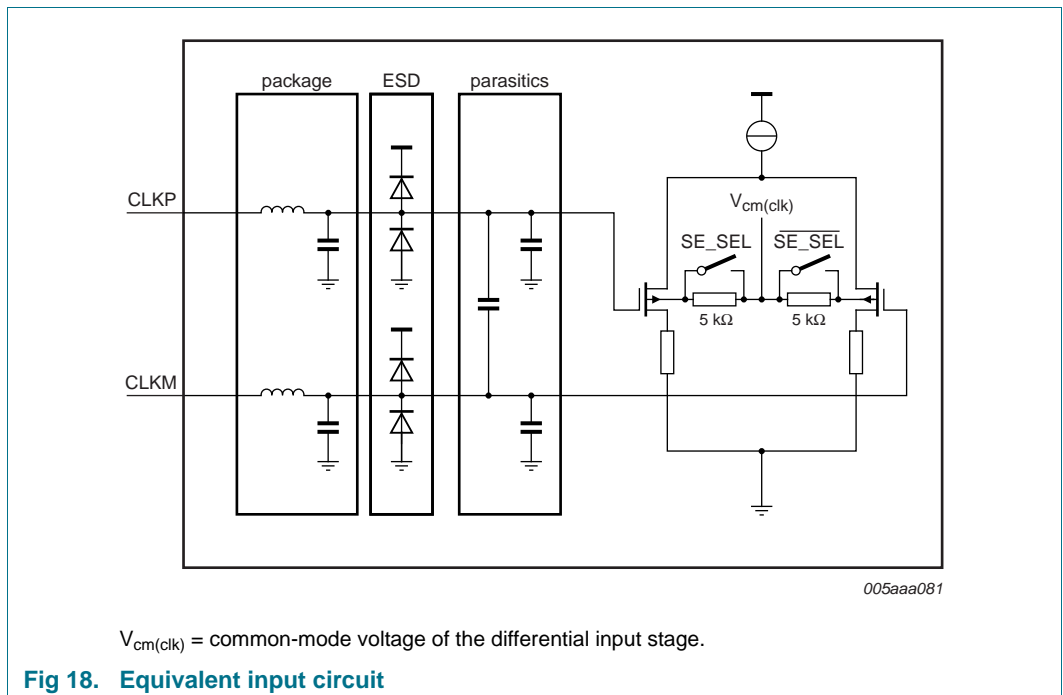

Fig 16. LVCMOS single-ended clock input



11.3.2 Equivalent input circuit

The equivalent circuit of the input clock buffer is shown in Figure 18. The common-mode voltage of the differential input stage is set via 5 kΩ internal resistors.



Single-ended or differential clock inputs can be selected via the SPI (see [Table 20](#)). If single-ended is selected, the input pin (CLKM or CLKP) is selected via control bit SE_SEL.

If single-ended is implemented without setting bit SE_SEL accordingly, the unused pin should be connected to ground via a capacitor.

11.3.3 Duty cycle stabilizer

The duty cycle stabilizer can improve the overall performance of the ADC by compensating the input clock signal duty cycle. When the duty cycle stabilizer is active (bit DCS_EN = logic 1; see [Table 20](#)), the circuit can handle signals with duty cycles of between 30 % and 70 % (typical). When the duty cycle stabilizer is disabled (DCS_EN = logic 0), the input clock signal should have a duty cycle of between 45 % and 55 %.

Table 12. Duty cycle stabilizer

Bit DCS_EN	Description
0	duty cycle stabilizer disable
1	duty cycle stabilizer enable

11.3.4 Clock input divider

The ADC1413D contains an input clock divider that divides the incoming clock by a factor of 2 (when bit CLKDIV2_SEL = logic 1; see [Table 20](#)). This feature allows the user to deliver a higher clock frequency with better jitter performance, leading to a better SNR result once acquisition has been performed.

11.4 Digital outputs

11.4.1 Serial output equivalent circuit

The JESD204A standard specifies that if the receiver and the transmitter are DC-coupled, both must be fed from the same supply.

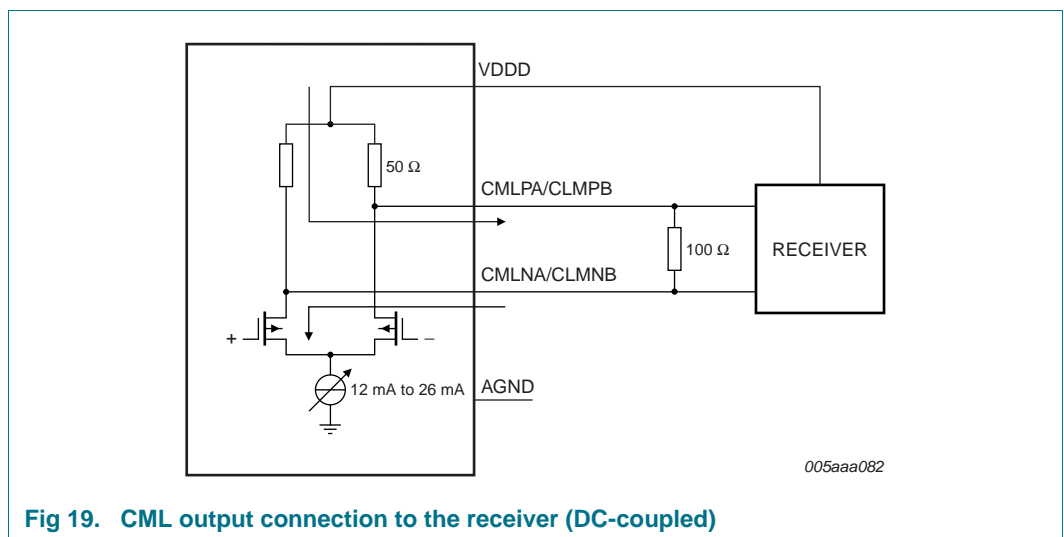

Fig 19. CML output connection to the receiver (DC-coupled)

The output should be terminated when 100 Ω (typical) is reached at the receiver side.

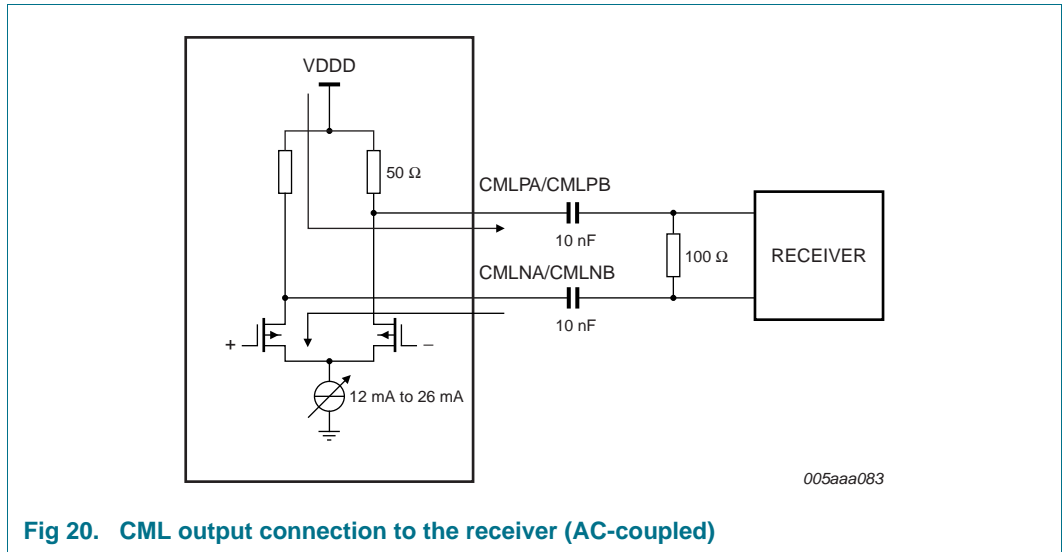

Fig 20. CML output connection to the receiver (AC-coupled)

11.5 JESD204A serializer

For more information about the JESD204A standard refer to the JEDEC web site.

11.5.1 Digital JESD204A formatter

The block placed after the ADC cores is used to implement all functionalities of the JESD204A standard. This ensures signal integrity and guarantees the clock and the data recovery at the receiver side.

The block is highly parameterized and can be configured in various ways depending on the sampling frequency and the number of lanes used.

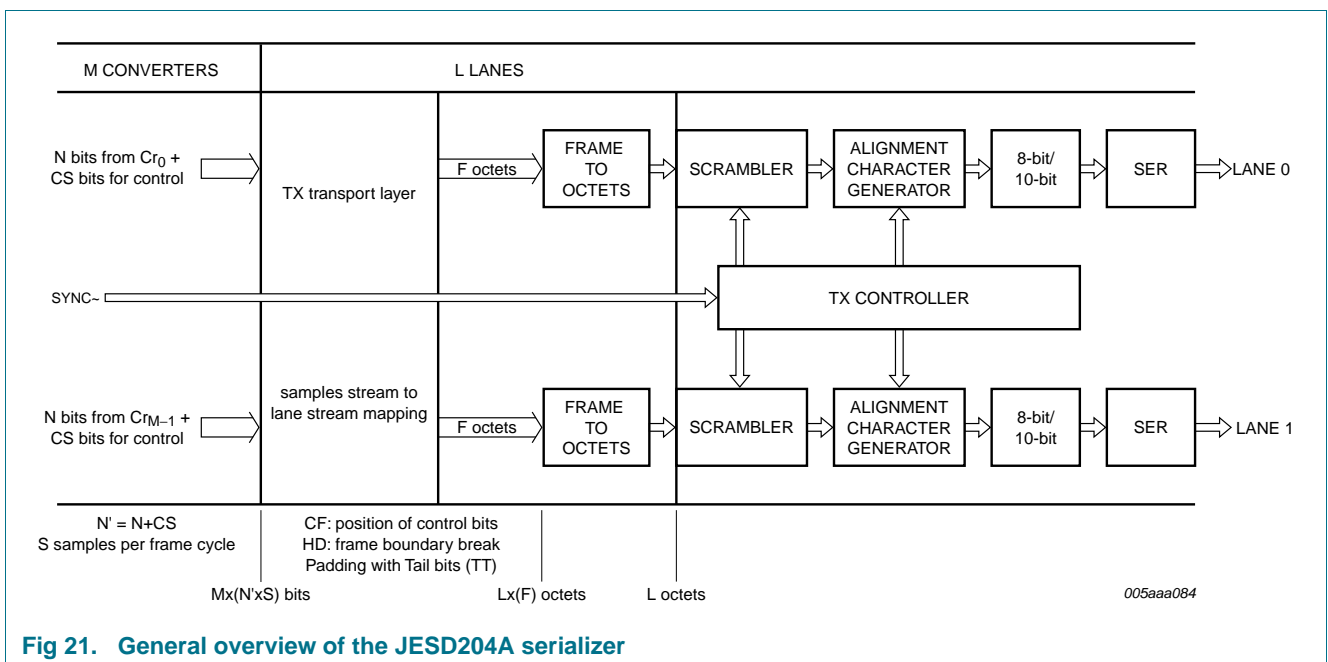

Fig 21. General overview of the JESD204A serializer

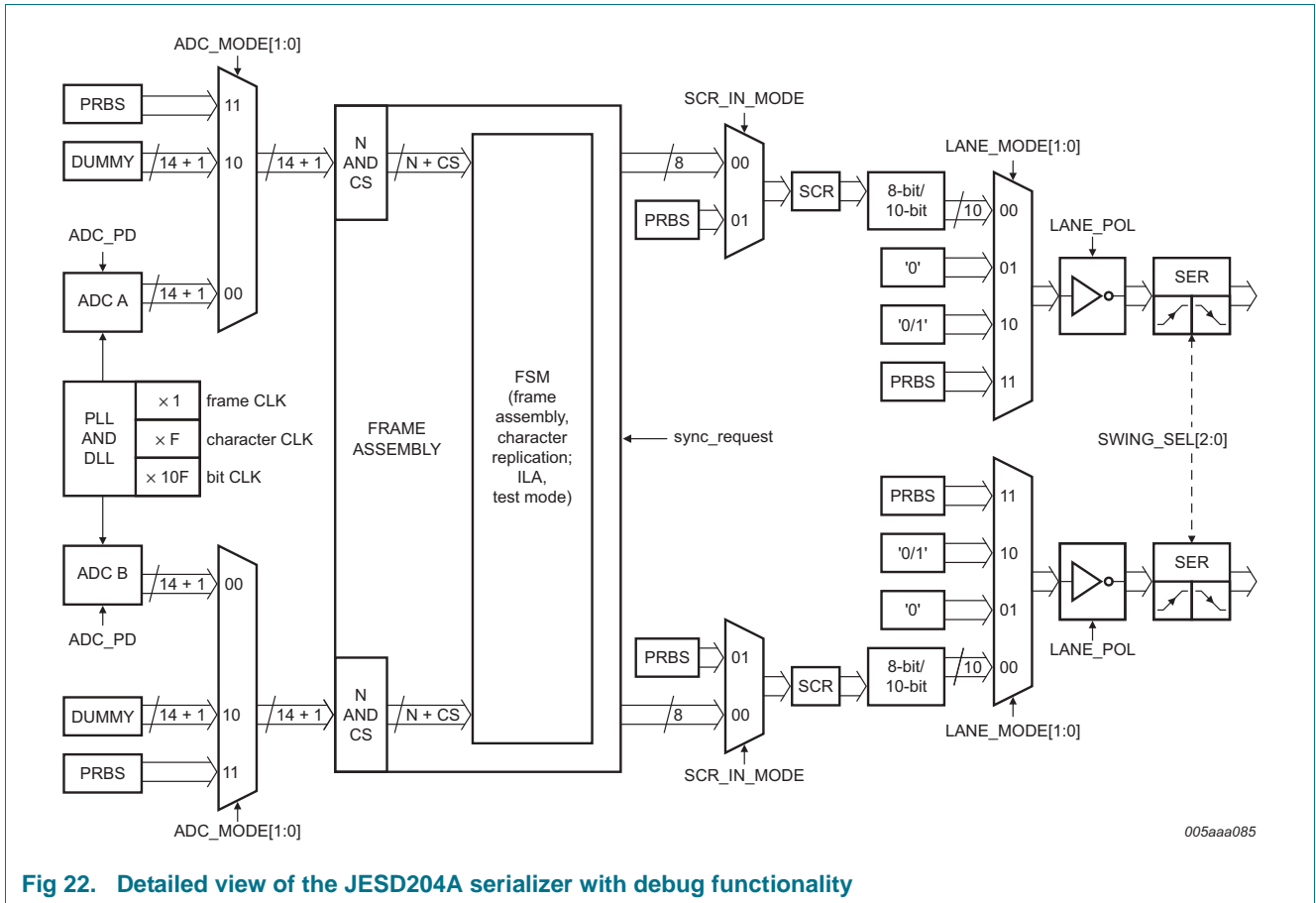

Fig 22. Detailed view of the JESD204A serializer with debug functionality

11.5.2 ADC core output codes versus input voltage

Table 13 shows the data output codes for a given analog input voltage.

Table 13. Output codes versus input voltage

INP – INM (V)	Offset binary	Two's complement	OTR
< -1	00 0000 0000 0000	10 0000 0000 0000	1
-1	00 0000 0000 0000	10 0000 0000 0000	0
-0.9998779	00 0000 0000 0001	10 0000 0000 0001	0
-0.9997559	00 0000 0000 0010	10 0000 0000 0010	0
-0.9996338	00 0000 0000 0011	10 0000 0000 0011	0
-0.9995117	00 0000 0000 0100	10 0000 0000 0100	0
....	0
-0.0002441	01 1111 1111 1110	11 1111 1111 1110	0
-0.0001221	01 1111 1111 1111	11 1111 1111 1111	0
0	10 0000 0000 0000	00 0000 0000 0000	0
+0.0001221	10 0000 0000 0001	00 0000 0000 0001	0
+0.0002441	10 0000 0000 0010	00 0000 0000 0010	0
....	0
+0.9995117	11 1111 1111 1011	01 1111 1111 1011	0

Table 13. Output codes versus input voltage ...continued

INP – INM (V)	Offset binary	Two's complement	OTR
+0.9996338	11 1111 1111 1100	01 1111 1111 1100	0
+0.9997559	11 1111 1111 1101	01 1111 1111 1101	0
+0.9998779	11 1111 1111 1110	01 1111 1111 1110	0
+1	11 1111 1111 1111	01 1111 1111 1111	0
> +1	11 1111 1111 1111	01 1111 1111 1111	1

11.6 Serial Peripheral Interface (SPI)

11.6.1 Register description

The ADC1413D serial interface is a synchronous serial communications port allowing easy interfacing with many industry microprocessors. It provides access to the registers that control the operation of the chip in both read and write modes.

This interface is configured as a 3-wire type (SDIO as bidirectional pin).

SCLK acts as the serial clock, and pin \overline{CS} acts as the serial chip select.

Each read/write operation is sequenced by the \overline{CS} signal and enabled by a LOW level to drive the chip with 2 bytes to 5 bytes, depending on the content of the instruction byte (see [Table 14](#)).

Table 14. SPI instruction bytes

Bit	MSB							LSB
	7	6	5	4	3	2	1	0
Description	R/W ^[1]	W1	W0	A12	A11	A10	A9	A8
	A7	A6	A5	A4	A3	A2	A1	A0

[1] R/W indicates whether a read (logic 1) or write (logic 0) transfer occurs after the instruction byte.

Table 15. Read or Write mode access description

R/W ^[1]	Description
0	Write mode operation
1	Read mode operation

[1] Bits W1 and W0 indicate the number of bytes transferred after the instruction byte.

Table 16. Number of bytes to be transferred

W1	W0	Number of bytes transferred
0	0	1 byte
0	1	2 bytes
1	0	3 bytes
1	1	4 or more bytes

Bits A12 to A0 indicate the address of the register being accessed. In the case of a multiple byte transfer, this address is the first register to be accessed. An address counter is incremented to access subsequent addresses.

The steps for a data transfer:

1. The falling edge on pin \overline{CS} in combination with a rising edge on pin SCLK determine the start of communications.
2. The first phase is the transfer of the 2-byte instruction.
3. The second phase is the transfer of the data which can vary in length but is always a multiple of 8 bits. The Most Significant Bit (MSB) is always sent first (for instruction and data bytes).
4. A rising edge on pin \overline{CS} indicates the end of data transmission.

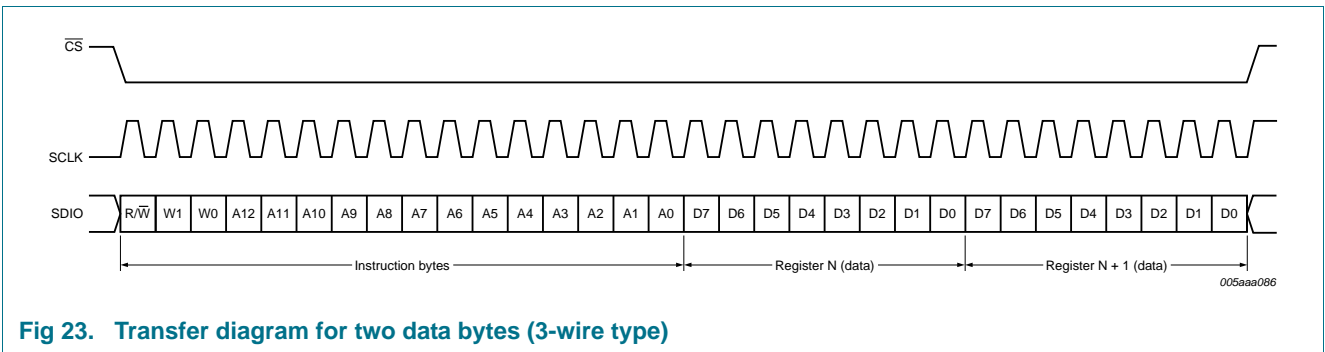

Fig 23. Transfer diagram for two data bytes (3-wire type)

11.6.2 Channel control

The two ADC channels can be configured at the same time or separately. By using the register “Channel index”, the user can choose which ADC channel receives the next SPI-instruction. By default the channel A and B receives the same instructions in write mode. In read mode only A is active.

Table 17. Register allocation map

Address (hex)	Register name	Access ^[1]	Bit definition								Default (bin)
			Bit 7	Bit 6	Bit 5	Bit 4	Bit 3	Bit 2	Bit 1	Bit 0	
ADC control register											
0003	Channel index	R/W	-	-	-	-	-	-	ADCB	ADCA	1111 1111
0005	Reset and Power-down modes	R/W	SW_RST	-	-	-	-	-	PD[1:0]		0000 0000
0006	Clock	R/W	-	-	-	SE_SEL	DIFF_SE	-	CLKDIV2_SEL	DCS_EN	0000 0001
0008	Vref	R/W	-	-	-	-	INTREF_EN	INTREF[2:0]		0000 0000	
0013	Offset	R/W	-	-	DIG_OFFSET[5:0]					0000 0000	
0014	Test pattern 1	R/W	-	-	-	-	-	TESTPAT_1[2:0]		0000 0000	
0015	Test pattern 2	R/W	TESTPAT_2[13:6]						0000 0000		
0016	Test pattern 3	R/W	TESTPAT_3[5:0]					-	-	0000 0000	
JESD204A control											
0801	Ser_Status	R	RXSYNC_ERROR	RESERVED[2:0]			0	0	POR_TST	RESERVED	0100 0000
0802	Ser_Reset	R/W	SW_RST	0	0	0	FSM_SW_RST	0	0	0	0000 0000
0803	Ser_Cfg_Setup	R/W	0	0	0	0	CFG_SETUP[3:0]			0000 1000	
0805	Ser_Control1	R/W	0	TRISTATE_CFG_PINS	SYNC_POL	SYNC_SINGLE_ENDED	1	REV_SCR	REV_ENCODER	REV_SERIAL	0100 1001
0806	Ser_Control2	R/W	0	0	0	0	0	0	SWAP_LANE_1_2	SWAP_ADC_0_1	0000 0011
0808	Ser_Analog_Ctrl	R/W	0	0	0	0	0	SWING_SEL[2:0]		0000 0011	
0809	Ser_ScramblerA	R/W	0	LSB_INIT[6:0]						0000 0000	
080A	Ser_ScramblerB	R/W	MSB_INIT[7:0]						1111 1111		
080B	Ser_PRBS_Ctrl	R/W	0	0	0	0	0	0	PRBS_TYPE[1:0]		0000 0000
0820	Cfg_0_DID	R*	DID[7:0]						1110 1101		
0821	Cfg_1_BID	R/W*	0	0	0	0	BID[3:0]			0000 1010	
0822	Cfg_3_SCR_L	R/W*	SCR	0	0	0	0	0	0	L	0000 0000
0823	Cfg_4_F	R/W*	0	0	0	0	0	F[2:0]		0000 0001	
0824	Cfg_5_K	R/W*	0	0	0	0	K[4:0]			0000 1000	
0825	Cfg_6_M	R/W*	0	0	0	0	0	0	0	M	0000 0000

Table 17. Register allocation map ...continued

Address (hex)	Register name	Access ^[1]	Bit definition							Default (bin)
			Bit 7	Bit 6	Bit 5	Bit 4	Bit 3	Bit 2	Bit 1	
0826	Cfg_7_CS_N	R/W*	0	CS[0]	0	0	N[3:0]			0100 0100
0827	Cfg_8_Np	R/W	0	0	0	NP[4:0]			0000 1111	
0828	Cfg_9_S	R/W*	0	0	0	0	0	0	S	0000 0000
0829	Cfg_10_HD_CF	R/W*	HD	0	0	0	0	CF[1:0]		0000 0000
082C	Cfg_01_2_LID	R/W*	0	0	0	LID[4:0]			0001 1011	
082D	Cfg_02_2_LID	R/W*	0	0	0	LID[4:0]			0001 1100	
084C	Cfg01_13_FCHK	R				FCHK[7:0]			0000 0000	
084D	Cfg02_13_FCHK	R				FCHK[7:0]			0000 0000	
0870	Lane0_0_Ctrl	R/W	0	SCR_IN_MODE	LANE_MODE[1:0]	0	LANE_POL	LANE_CLK_POS_EDGE	LANE_PD	0000 0001
0871	Lane1_0_Ctrl	R/W	0	SCR_IN_MODE	LANE_MODE[1:0]	0	LANE_POL	LANE_CLK_POS_EDGE	LANE_PD	0000 0000
0890	ADCA_0_Ctrl	R/W	0	0	ADC_MODE[1:0]	0	0	0	ADC_PD	0000 0001
0891	ADCB_0_Ctrl	R/W	0	0	ADC_MODE[1:0]	0	0	0	ADC_PD	0000 0000

[1] an "*" in the Access column means that this register is subject to control access conditions in Write mode.

11.6.3 Register description

11.6.3.1 ADC control registers

Table 18. Register Channel index (address 0003h)

Default values are highlighted.

Bit	Symbol	Access	Value	Description
7 to 2	-	-	111111	not used
1	ADCB	R/W		ADC B gets the next SPI command:
			0	ADC B not selected
			1	ADC B selected
0	ADCA	R/W		ADC A gets the next SPI command:
			0	ADC A not selected
			1	ADC A selected

Table 19. Register Reset and Power-down mode (address 0005h)

Default values are highlighted.

Bit	Symbol	Access	Value	Description
7	SW_RST	R/W		reset digital part:
			0	no reset
			1	performs a reset of the digital part
6 to 2	-	-	00000	not used
1 to 0	PD[1:0]	R/W		Power-down mode:
			00	normal (power-up)
			01	full power-down
			10	sleep
			11	normal (power-up)

Table 20. Register Clock (address 0006h)

Default values are highlighted.

Bit	Symbol	Access	Value	Description
7 to 5	-	-	000	not used
4	SE_SEL	R/W		select SE clock input pin:
			0	select CLKM input
			1	select CLKP input
3	DIFF_SE	R/W		differential/single-ended clock input select:
			0	fully differential
			1	single-ended
2	-	-	0	not used
1	CLKDIV2_SEL	R/W		select clock input divider by 2:
			0	disable
			1	active
0	DCS_EN	R/W		duty cycle stabilizer enable:
			0	disable
			1	active

Table 21. Register Vref (address 0008h)

Default values are highlighted.

Bit	Symbol	Access	Value	Description
7 to 4	-	-	0000	not used
3	INTREF_EN	R/W		enable internal programmable VREF mode:
			0	disable
			1	active
2 to 0	INTREF[2:0]	R/W		programmable internal reference:
			000	0 dB (FS=2 V)
			001	-1 dB (FS=1.78 V)
			010	-2 dB (FS=1.59 V)
			011	-3 dB (FS=1.42 V)
			100	-4 dB (FS=1.26 V)
			101	-5 dB (FS=1.12 V)
			110	-6 dB (FS=1 V)
			111	not used

Table 22. Digital Offset adjustment (address 0013h)

Default values are highlighted.

Register Offset		
Decimal	DIG_OFFSET[5:0]	
+31	011111	+31 LSB
...
0	000000	0
...
-32	100000	-32 LSB

Table 23. Register Test pattern 1 (address 0014h)

Default values are highlighted.

Bit	Symbol	Access	Value	Description
7 to 3	-	-	00000	not used
2 to 0	TESTPAT_1[2:0]	R/W		digital test pattern:
			000	off
			001	mid-scale
			010	- FS
			011	+ FS
			100	toggle '1111..1111'/'0000..0000'
			101	custom test pattern, to be written in register 0015h and 0016h
			110	'010101...'
			111	'101010...'

Table 24. Register Test pattern 2 (address 0015h)*Default values are highlighted.*

Bit	Symbol	Access	Value	Description
7 to 0	TESTPAT_2[13:6]	R/W	00000000	custom digital test pattern (bit 13 to 6)

Table 25. Register Test pattern 3 (address 0016h)*Default values are highlighted.*

Bit	Symbol	Access	Value	Description
7 to 2	TESTPAT_3[5:0]	R/W	000000	custom digital test pattern (bit 5 to 0)
1 to 0	-	-	00	not used

11.6.4 JESD204A digital control registers

Table 26. Ser_Status (address 0801h)*Default values are highlighted.*

Bit	Symbol	Access	Value	Description
7	RXSYNC_ERROR	R	0	set to 1 when a synchronization error occurs
6 to 4	RESERVED[2:0]	-	100	reserved
3 to 2	-	-	00	not used
1	POR_TST	R	0	power-on-reset
0	RESERVED	-	0	reserved

Table 27. Ser_Reset (address 0802h)*Default values are highlighted.*

Bit	Symbol	Access	Value	Description
7	SW_RST	R/W	0	initiates a software reset of the JESD204A unit
6 to 4	-	-	000	not used
3	FSM_SW_RST	R/W	0	initiates a software reset of the internal state machine of JESD204A unit
2 to 0	-	-	000	not used

Table 28. Ser_Cfg_Setup (address 0803h)

Default values are highlighted.

Bit	Symbol	Access	Value	Description
7 to 4	-	-	0000	not used
3 to 0	CFG_SETUP[3:0]	R/W		quick configuration of JESD204A. These settings overrule the configuration of pins CFG3 to CFG0 (see Table 29).

Table 29. JESD204A configuration table

CFG_SETUP[3:0]	ADC A	ADC B	Lane 0	Lane 1	F ^[1]	HD ^[1]	K ^[1]	M ^[1]	L ^[1]	Comment	CS ^[1]	CF ^[1]	S ^[1]	
0	0000	ON	ON	ON	ON	2	0	9	2	2	(F × K) ≥ 17	1	0	1
1	0001	ON	ON	ON	OFF	4	0	5	2	1	(F × K) ≥ 17	1	0	1
2	0010	ON	ON	OFF	ON	4	0	5	2	1	(F × K) ≥ 17	1	0	1
3	0011	ON	OFF	ON	ON	1	1	17	1	2	(F × K) ≥ 17	1	0	1
4	0100	OFF	ON	ON	ON	1	1	17	1	2	(F × K) ≥ 17	1	0	1
5	0101	ON	OFF	ON	OFF	2	0	9	1	1	(F × K) ≥ 17	1	0	1
6	0110	ON	OFF	OFF	ON	2	0	9	1	1	(F × K) ≥ 17	1	0	1
7	0111	OFF	ON	ON	OFF	2	0	9	1	1	(F × K) ≥ 17	1	0	1
8	1000	OFF	ON	OFF	ON	2	0	9	1	1	(F × K) ≥ 17	1	0	1
9	1001													
10	1010													
11	1011													
12	1100													
13	1101													
14	1110	ON	ON	ON	ON	2	0	9	2	2	test: loop alignment	1	0	1
15	1111	OFF	OFF	OFF	OFF	2	0	9	2	2	chip power-down	1	0	1

- [1] F: Octets per frame clock cycle
- HD: High-density mode
- K: Frame per multi-frame
- M: Converters per device
- L: Lane per converter device
- CS: Number of control bits per conversion sample
- CF: Control words per frame clock cycle and link
- S: Number of samples transmitted per single converter per frame cycle

Table 30. Ser_Control1 (address 0805h)

Default values are highlighted.

Bit	Symbol	Access	Value	Description
7	-	-	0	not used
6	TRISTATE_CFG_PINS	R/W	1	pins CFG3 to CFG0 are set to high-impedance. Switch to 0 automatically after start-up or reset.
5	SYNC_POL	R/W		defines the sync signal polarity:
			0	synchronization signal is active LOW
			1	synchronization signal is active HIGH
4	SYNC_SINGLE_ENDED	R/W		defines the input mode of the sync signal:
			0	synchronization input mode is set in Differential mode
			1	synchronization input mode is set in Single-ended mode
3	-	-	1	not used
2	REV_SCR	-		LSBs are swapped with MSBs at the scrambler input:
			0	disable
			1	enable
1	REV_ENCODER	-		LSBs are swapped with MSBs at the 8-bit/10-bit encoder input:
			0	disable
			1	enable
0	REV_SERIAL	-		LSBs are swapped with MSBs at the lane input:
			0	disable
			1	enable

Table 31. Ser_Control2 (address 0806h)

Default values are highlighted.

Bit	Symbol	Access	Value	Description
7 to 2	-	-	000000	not used
1	SWAP_LANE_0_1	R/W		swaps the outputs of the JESD204A unit. (output buffer A is connected to Lane 1, output buffer B is connected to Lane 0):
			0	disable
			1	enable
0	SWAP_ADC_A_B	R/W		swaps the inputs of the JESD204A unit. (ADC A output is connected to input B, ADC B is connected to input A):
			0	disable
			1	enable

Table 32. Ser_Analog_Ctrl (address 0808h)

Default values are highlighted.

Bit	Symbol	Access	Value	Description
7 to 3	-	-	00000	not used
2 to 0	SWING_SEL[2:0]	R/W	011	defines the swing output for the lane pads

Table 33. Ser_ScramblerA (address 0809h)

Default values are highlighted.

Bit	Symbol	Access	Value	Description
7	-	-	0	not used
6 to 0	LSB_INIT[6:0]	R/W	0000000	defines the initialization vector for the scrambler polynomial (lower)

Table 34. Ser_ScramblerB (address 080Ah)

Default values are highlighted.

Bit	Symbol	Access	Value	Description
7 to 0	MSB_INIT[7:0]	R/W	11111111	defines the initialization vector for the scrambler polynomial (upper)

Table 35. Ser_PRBS_Ctrl (address 080Bh)

Default values are highlighted.

Bit	Symbol	Access	Value	Description
7 to 2	-	-	000000	not used
1 to 0	PRBS_TYPE[1:0]	R/W		defines the type of Pseudo-Random Binary Sequence (PRBS) generator to be used:
			00 (reset)	PRBS-7
			01	PRBS-7
			10	PRBS-23
			11	PRBS-31

Table 36. Cfg_0_DID (address 0820h)

Default values are highlighted.

Bit	Symbol	Access	Value	Description
7 to 0	DID[7:0]	R	11101101	defines the device (= link) identification number

Table 37. Cfg_1_BID (address 0821h)

Default values are highlighted.

Bit	Symbol	Access	Value	Description
7 to 4	-	-	0000	not used
3 to 0	BID[3:0]	R/W	1010	defines the bank ID – extension to DID

Table 38. Cfg_3_SCR_L (address 0822h)

Default values are highlighted.

Bit	Symbol	Access	Value	Description
7	SCR	R/W	0	scrambling enabled
6 to 1	-	-	000000	not used
0	L	R/W	0	defines the number of lanes per converter device, minus 1

Table 39. Cfg_4_F (address 0823h)

Default values are highlighted.

Bit	Symbol	Access	Value	Description
7 to 3	-	-	00000	not used
2 to 0	F[2:0]	R/W	001	defines the number of octets per frame, minus 1

Table 40. Cfg_5_K (address 0824h)

Default values are highlighted.

Bit	Symbol	Access	Value	Description
7 to 5	-	-	000	not used
4 to 0	K[4:0]	R/W	01000	defines the number of frames per multiframe, minus 1

Table 41. Cfg_6_M (address 0825h)

Default values are highlighted.

Bit	Symbol	Access	Value	Description
7 to 1	-	-	0000000	not used
0	M	R/W	0	defines the number of converters per device, minus 1

Table 42. Cfg_7_CS_N (address 0826h)

Default values are highlighted.

Bit	Symbol	Access	Value	Description
7	-	-	0	not used
6	CS[0]	R/W	1	defines the number of control bits per sample, minus 1
5 to 4	-	R	00	not used
3 to 0	N[3:0]	R/W	0100	defines the converter resolution

Table 43. Cfg_8_Np (address 0827h)

Default values are highlighted.

Bit	Symbol	Access	Value	Description
7 to 5	-	-	000	not used
4 to 0	NP[4:0]	R/W	01111	defines the total number of bits per sample, minus 1

Table 44. Cfg_9_S (address 0828h)

Default values are highlighted.

Bit	Symbol	Access	Value	Description
7 to 1	-	-	0000000	not used
0	S	R/W	0	defines number of samples per converter per frame cycle

Table 45. Cfg_10_HD_CF (address 0829h)

Default values are highlighted.

Bit	Symbol	Access	Value	Description
7	HD	R/W	0	defines high density format
6 to 2	-	-	00000	not used
1 to 0	CF[1:0]	R/W	00	defines number of control words per frame clock cycle per link.

Table 46. Cfg_01_2_LID (address 082Ch)

Default values are highlighted.

Bit	Symbol	Access	Value	Description
7 to 5	-	-	000	not used
4 to 0	LID[4:0]	R/W	11011	defines lane 0 identification number

Table 47. Cfg_02_2_LID (address 082Dh)

Default values are highlighted.

Bit	Symbol	Access	Value	Description
7 to 5	-	-	000	not used
4 to 0	LID[4:0]	R/W	11100	defines lane 1 identification number

Table 48. Cfg01_13_FCHK (address 084Ch)

Default values are highlighted.

Bit	Symbol	Access	Value	Description
7 to 0	FCHK[7:0]	R	00000000	defines the checksum value for lane 0 checksum corresponds to the sum of all the link configuration parameters modulo 256 (as defined in JEDEC Standard No.204A)

Table 49. Cfg02_13_FCHK (address 084Dh)

Default values are highlighted.

Bit	Symbol	Access	Value	Description
7 to 0	FCHK[7:0]	R	00000000	defines the checksum value for lane 1 checksum corresponds to the sum of all the link configuration parameters modulo 256 (as defined in JEDEC Standard No.204A)

Table 50. Lane0_0_Ctrl (address 0870h)

Default values are highlighted.

Bit	Symbol	Access	Value	Description
7	-	-	0	not used
6	SCR_IN_MODE	R/W		defines the input type for scrambler and 8-bit/10-bit units:
			0 (reset)	(normal mode) = input of the scrambler and 8-bit/10-bit units is the output of the frame assembly unit.
			1	input of the scrambler and 8-bit/10-bit units is the PRBS generator (PRBS type is defined with "PRBS_TYPE[1:0]" (Ser_PRBS_Ctrl register)
5 to 4	LANE_MODE[1:0]	R/W		defines output type of lane output unit:
			00 (reset)	normal mode: lane output is the 8-bit/10-bit output unit
			01	constant mode: lane output is set to a constant (0 × 0)
			10	toggle mode: lane output is toggling between 0 × 0 and 0 × 1
			11	PRBS mode: lane output is the PRBS generator (PRBS type is defined with "PRBS_TYPE[1:0]" (Ser_PRBS_Ctrl register)
3	-	-	0	not used
2	LANE_POL	R/W		defines lane polarity:
			0	lane polarity is normal
			1	lane polarity is inverted
1	LANE_CLK_POS_EDGE	R/W		defines lane clock polarity:
			0	lane clock provided to the serializer is active on positive edge
			1	lane clock provided to the serializer is active on negative edge

Table 50. Lane0_0_Ctrl (address 0870h) ...continued

Default values are highlighted.

Bit	Symbol	Access	Value	Description
0	LANE_PD	R/W		lane power-down control:
			0	lane is operational
			1	lane is in Power-down mode

Table 51. Lane1_0_Ctrl (address 0871h)

Default values are highlighted.

Bit	Symbol	Access	Value	Description
7	-	-	0	not used
6	SCR_IN_MODE	R/W		defines the input type for scrambler and 8-bit/10-bit units:
			0 (reset)	(normal mode) = input of the scrambler and 8-bit/10-bit units is the output of the frame assembly unit.
			1	input of the scrambler and 8-bit/10-bit units is the PRBS generator (PRBS type is defined with "PRBS_TYPE[1:0]" (Ser_PRBS_Ctrl register)
5 to 4	LANE_MODE[1:0]	R/W		defines output type of lane output unit:
			00 (reset)	normal mode: lane output is the 8-bit/10-bit output unit
			01	constant mode: lane output is set to a constant (0x0)
			10	toggle mode: lane output is toggling between 0x0 and 0x1
			11	PRBS mode: lane output is the PRBS generator (PRBS type is defined with "PRBS_TYPE[1:0]" (Ser_PRBS_Ctrl register)
3	-	-	0	not used
2	LANE_POL	R/W		defines lane polarity:
			0	lane polarity is normal
			1	lane polarity is inverted
1	LANE_CLK_POS_EDGE	R/W		defines lane clock polarity:
			0	lane clock provided to the serializer is active on positive edge
			1	lane clock provided to the serializer is active on negative edge
0	LANE_PD	R/W		lane power-down control:
			0	lane is operational
			1	lane is in Power-down mode

Table 52. ADCA_0_Ctrl (address 0890h)

Default values are highlighted.

Bit	Symbol	Access	Value	Description
7 to 6	-	-	00	not used
5 to 4	ADC_MODE[1:0]	R/W		defines input type of JESD204A unit:
			00 (reset)	ADC output is connected to the JESD204A input
			01	not used
			10	JESD204A input is fed with a dummy constant, set to: OTR = 0 and ADC[13:0] = "10011011101010"
11	JESD204A is fed with a PRBS generator (PRBS type is defined with "PRBS_TYPE[1:0]" (Ser_PRBS_Ctrl register)			
3 to 1	-	-	000	not used
0	ADC_PD	R/W		ADC power-down control:
			0	ADC is operational
			1	ADC is in Power-down mode

Table 53. ADCB_0_Ctrl (address 0891h)

Default values are highlighted.

Bit	Symbol	Access	Value	Description
7 to 6	-	-	00	not used
5 to 4	ADC_MODE[1:0]	R/W		defines input type of JESD204A unit
			00 (reset)	ADC output is connected to the JESD204A input
			01	not used
			10	JESD204A input is fed with a dummy constant, set to: OTR = 0 and ADC[13:0] = "10011011101010"
11	JESD204A is fed with a PRBS generator (PRBS type is defined with "PRBS_TYPE[1:0]" (Ser_PRBS_Ctrl register)			
3 to 1	-	-	000	not used
0	ADC_PD	R/W		ADC power-down control:
			0	ADC is operational
			1	ADC is in Power-down mode

12. Package outline

HVQFN56: plastic thermal enhanced very thin quad flat package; no leads; 56 terminals; body 8 x 8 x 0.85 mm

SOT684-7

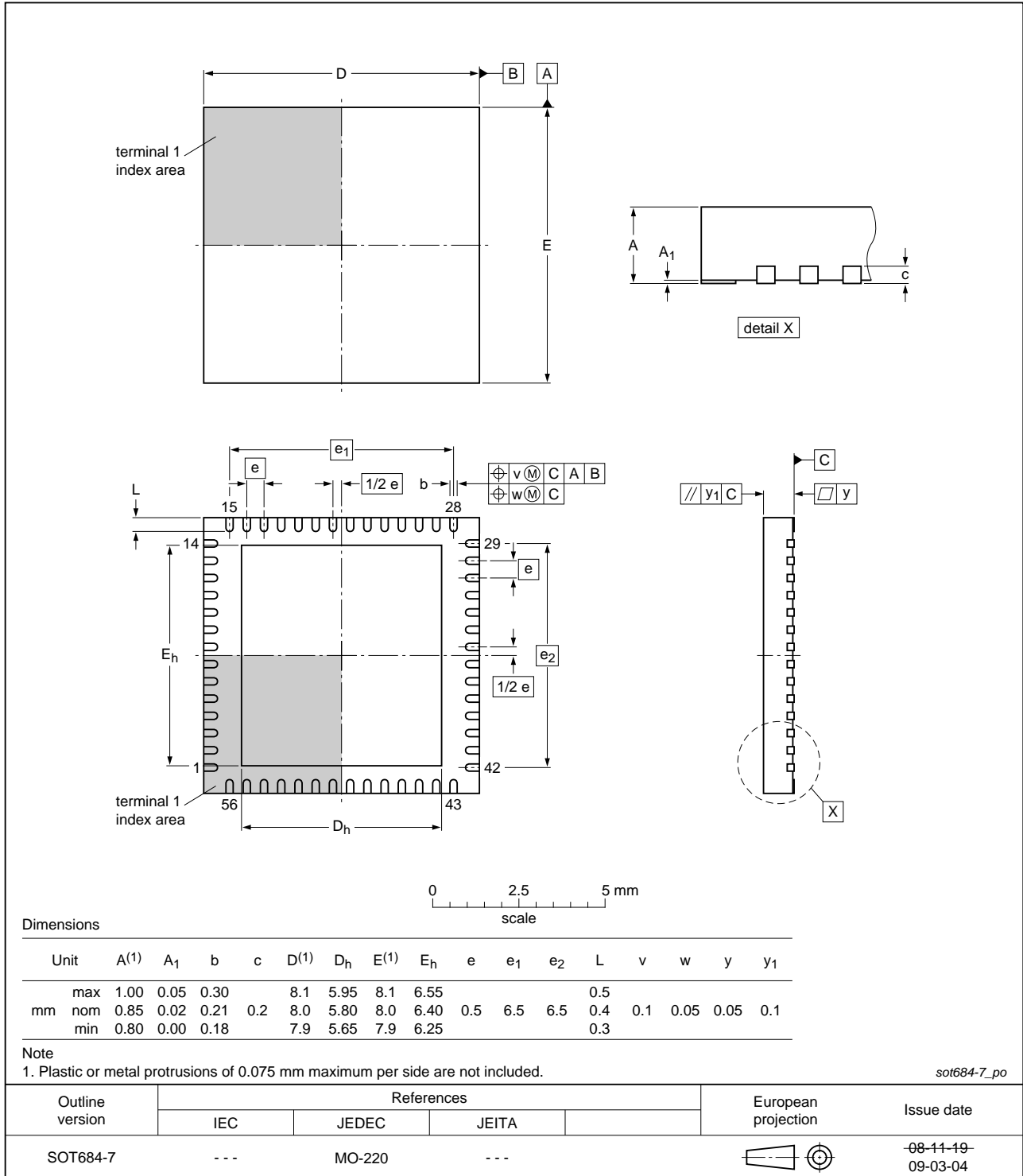

Fig 24. Package outline SOT684-7 (HVQFN56)

13. Abbreviations

Table 54. Abbreviations

Acronym	Description
ADC	Analog-to-Digital Converter
DCS	Duty Cycle Stabilizer
ESD	ElectroStatic Discharge
IF	Intermediate Frequency
IMD	InterModulation Distortion
LSB	Least Significant Bit
LVCMOS	Low Voltage Complementary Metal Oxide Semiconductor
LVPECL	Low-Voltage Positive Emitter-Coupled Logic
MSB	Most Significant Bit
OTR	Out-of-Range
PRBS	Pseudo-Random Binary Sequence
SFDR	Spurious-Free Dynamic Range
SNR	Signal-to-Noise Ratio
SPI	Serial Peripheral Interface
TX	Transmitter

14. Revision history

Table 55. Revision history

Document ID	Release date	Data sheet status	Change notice	Supersedes
ADC1413D_SER v.6	20110608	Product data sheet	-	ADC1413D_SER v.5
Modifications:	<ul style="list-style-type: none"> • Section 10.2 "Clock and digital output timing" has been updated. 			
ADC1413D_SER v.5	20110209	Product data sheet	-	ADC1413D_SER v.4
ADC1413D_SER v.4	20100423	Preliminary data sheet	-	ADC1413D_SER v.3
ADC1413D_SER v.3	20100412	Objective data sheet	-	ADC1413D065_080_105_125_2
ADC1413D065_080_105_125_2	20090604	Objective data sheet	-	ADC1413D065_080_105_125_1
ADC1413D065_080_105_125_1	20090528	Objective data sheet	-	-

15. Legal information

15.1 Data sheet status

Document status ^{[1][2]}	Product status ^[3]	Definition
Objective [short] data sheet	Development	This document contains data from the objective specification for product development.
Preliminary [short] data sheet	Qualification	This document contains data from the preliminary specification.
Product [short] data sheet	Production	This document contains the product specification.

[1] Please consult the most recently issued document before initiating or completing a design.

[2] The term 'short data sheet' is explained in section "Definitions".

[3] The product status of device(s) described in this document may have changed since this document was published and may differ in case of multiple devices. The latest product status information is available on the Internet at URL <http://www.nxp.com>.

15.2 Definitions

Draft — The document is a draft version only. The content is still under internal review and subject to formal approval, which may result in modifications or additions. NXP Semiconductors does not give any representations or warranties as to the accuracy or completeness of information included herein and shall have no liability for the consequences of use of such information.

Short data sheet — A short data sheet is an extract from a full data sheet with the same product type number(s) and title. A short data sheet is intended for quick reference only and should not be relied upon to contain detailed and full information. For detailed and full information see the relevant full data sheet, which is available on request via the local NXP Semiconductors sales office. In case of any inconsistency or conflict with the short data sheet, the full data sheet shall prevail.

Product specification — The information and data provided in a Product data sheet shall define the specification of the product as agreed between NXP Semiconductors and its customer, unless NXP Semiconductors and customer have explicitly agreed otherwise in writing. In no event however, shall an agreement be valid in which the NXP Semiconductors product is deemed to offer functions and qualities beyond those described in the Product data sheet.

15.3 Disclaimers

Limited warranty and liability — Information in this document is believed to be accurate and reliable. However, NXP Semiconductors does not give any representations or warranties, expressed or implied, as to the accuracy or completeness of such information and shall have no liability for the consequences of use of such information.

In no event shall NXP Semiconductors be liable for any indirect, incidental, punitive, special or consequential damages (including - without limitation - lost profits, lost savings, business interruption, costs related to the removal or replacement of any products or rework charges) whether or not such damages are based on tort (including negligence), warranty, breach of contract or any other legal theory.

Notwithstanding any damages that customer might incur for any reason whatsoever, NXP Semiconductors' aggregate and cumulative liability towards customer for the products described herein shall be limited in accordance with the *Terms and conditions of commercial sale* of NXP Semiconductors.

Right to make changes — NXP Semiconductors reserves the right to make changes to information published in this document, including without limitation specifications and product descriptions, at any time and without notice. This document supersedes and replaces all information supplied prior to the publication hereof.

Suitability for use — NXP Semiconductors products are not designed, authorized or warranted to be suitable for use in life support, life-critical or safety-critical systems or equipment, nor in applications where failure or

malfunction of an NXP Semiconductors product can reasonably be expected to result in personal injury, death or severe property or environmental damage. NXP Semiconductors accepts no liability for inclusion and/or use of NXP Semiconductors products in such equipment or applications and therefore such inclusion and/or use is at the customer's own risk.

Applications — Applications that are described herein for any of these products are for illustrative purposes only. NXP Semiconductors makes no representation or warranty that such applications will be suitable for the specified use without further testing or modification.

Customers are responsible for the design and operation of their applications and products using NXP Semiconductors products, and NXP Semiconductors accepts no liability for any assistance with applications or customer product design. It is customer's sole responsibility to determine whether the NXP Semiconductors product is suitable and fit for the customer's applications and products planned, as well as for the planned application and use of customer's third party customer(s). Customers should provide appropriate design and operating safeguards to minimize the risks associated with their applications and products.

NXP Semiconductors does not accept any liability related to any default, damage, costs or problem which is based on any weakness or default in the customer's applications or products, or the application or use by customer's third party customer(s). Customer is responsible for doing all necessary testing for the customer's applications and products using NXP Semiconductors products in order to avoid a default of the applications and the products or of the application or use by customer's third party customer(s). NXP does not accept any liability in this respect.

Limiting values — Stress above one or more limiting values (as defined in the Absolute Maximum Ratings System of IEC 60134) will cause permanent damage to the device. Limiting values are stress ratings only and (proper) operation of the device at these or any other conditions above those given in the Recommended operating conditions section (if present) or the Characteristics sections of this document is not warranted. Constant or repeated exposure to limiting values will permanently and irreversibly affect the quality and reliability of the device.

Terms and conditions of commercial sale — NXP Semiconductors products are sold subject to the general terms and conditions of commercial sale, as published at <http://www.nxp.com/profile/terms>, unless otherwise agreed in a valid written individual agreement. In case an individual agreement is concluded only the terms and conditions of the respective agreement shall apply. NXP Semiconductors hereby expressly objects to applying the customer's general terms and conditions with regard to the purchase of NXP Semiconductors products by customer.

No offer to sell or license — Nothing in this document may be interpreted or construed as an offer to sell products that is open for acceptance or the grant, conveyance or implication of any license under any copyrights, patents or other industrial or intellectual property rights.

Export control — This document as well as the item(s) described herein may be subject to export control regulations. Export might require a prior authorization from national authorities.

Non-automotive qualified products — Unless this data sheet expressly states that this specific NXP Semiconductors product is automotive qualified, the product is not suitable for automotive use. It is neither qualified nor tested in accordance with automotive testing or application requirements. NXP Semiconductors accepts no liability for inclusion and/or use of non-automotive qualified products in automotive equipment or applications.

In the event that customer uses the product for design-in and use in automotive applications to automotive specifications and standards, customer (a) shall use the product without NXP Semiconductors' warranty of the product for such automotive applications, use and specifications, and (b) whenever customer uses the product for automotive applications beyond

NXP Semiconductors' specifications such use shall be solely at customer's own risk, and (c) customer fully indemnifies NXP Semiconductors for any liability, damages or failed product claims resulting from customer design and use of the product for automotive applications beyond NXP Semiconductors' standard warranty and NXP Semiconductors' product specifications.

15.4 Trademarks

Notice: All referenced brands, product names, service names and trademarks are the property of their respective owners.

16. Contact information

For more information, please visit: <http://www.nxp.com>

For sales office addresses, please send an email to: salesaddresses@nxp.com

17. Contents

1	General description	1	15	Legal information	41
2	Features and benefits	1	15.1	Data sheet status	41
3	Applications	2	15.2	Definitions	41
4	Ordering information	2	15.3	Disclaimers	41
5	Block diagram	3	15.4	Trademarks	42
6	Pinning information	4	16	Contact information	42
6.1	Pinning	4	17	Contents	43
6.2	Pin description	4			
7	Limiting values	6			
8	Thermal characteristics	6			
9	Static characteristics	7			
10	Dynamic characteristics	10			
10.1	Dynamic characteristics	10			
10.2	Clock and digital output timing	11			
10.3	Serial output timing	12			
10.4	SPI timing	13			
11	Application information	14			
11.1	Analog inputs	14			
11.1.1	Input stage description	14			
11.1.2	Anti-kickback circuitry	15			
11.1.3	Transformer	15			
11.2	System reference and power management ..	16			
11.2.1	Internal/external reference	16			
11.2.2	Programmable full-scale	18			
11.2.3	Common-mode output voltage ($V_{O(cm)}$)	19			
11.2.4	Biasing	19			
11.3	Clock input	19			
11.3.1	Drive modes	19			
11.3.2	Equivalent input circuit	20			
11.3.3	Duty cycle stabilizer	21			
11.3.4	Clock input divider	21			
11.4	Digital outputs	21			
11.4.1	Serial output equivalent circuit	21			
11.5	JESD204A serializer	22			
11.5.1	Digital JESD204A formatter	22			
11.5.2	ADC core output codes versus input voltage ..	23			
11.6	Serial Peripheral Interface (SPI)	24			
11.6.1	Register description	24			
11.6.2	Channel control	25			
11.6.3	Register description	28			
11.6.3.1	ADC control registers	28			
11.6.4	JESD204A digital control registers	30			
12	Package outline	38			
13	Abbreviations	39			
14	Revision history	40			

Please be aware that important notices concerning this document and the product(s) described herein, have been included in section 'Legal information'.

© NXP B.V. 2011.

All rights reserved.

For more information, please visit: <http://www.nxp.com>

For sales office addresses, please send an email to: salesaddresses@nxp.com

Date of release: 8 June 2011

Document identifier: ADC1413D_SER