

# ADC1213S series

Single 12-bit ADC; 65 Msps, 80 Msps, 105 Msps or 125 Msps;  
serial JESD204A interface

Rev. 2 — 9 June 2011

Product data sheet

## 1. General description

---

The ADC1213S is a single channel 12-bit Analog-to-Digital Converter (ADC) optimized for high dynamic performance and low power at sample rates up to 125 Msps. Pipelined architecture and output error correction ensure the ADC1213S is accurate enough to guarantee zero missing codes over the entire operating range. Supplied from a 3 V source for analog and a 1.8 V source for the output driver, it outputs data in serial mode via a single differential lane, which complies with the JESD204A standard. The integration of Serial Peripheral Interface (SPI) allows the user to easily configure the ADCs and the serial output modes. The device also includes a programmable full-scale SPI to allow a flexible input voltage range from 1 V (p-p) to 2 V (p-p).

Excellent dynamic performance is maintained from the baseband to input frequencies of 170 MHz or more, making the ADC1213S ideal for use in communications, imaging, and medical applications.

## 2. Features and benefits

---

- SNR, 70 dBFS; SFDR, 86 dBc
- Sample rates up to 125 Msps
- Single channel, 12-bit pipelined ADC core
- 3 V, 1.8 V power supplies
- Flexible input voltage range: 1 V (p-p) to 2 V (p-p)
- Serial output
- Compliant with JESD204A serial transmission standard
- Pin compatible with ADC1613S series, ADC1413S series, and ADC1113S125
- Input bandwidth, 600 MHz
- Power dissipation, 550 mW at 80 Msps
- SPI register programming
- Duty cycle stabilizer
- High Intermediate Frequency (IF) capability
- Offset binary, two's complement, gray code
- Power-down mode and Sleep mode
- HVQFN32 package

## 3. Applications

---

- Wireless and wired broadband communications
- Spectral analysis
- Ultrasound equipment
- Portable instrumentation
- Imaging systems



## 4. Ordering information

Table 1. Ordering information

Type number	Sampling frequency (Msps)	Package		
		Name	Description	Version
ADC1213S125HN/C1	125	HVQFN32R	plastic thermal enhanced very thin quad flat package; no leads; 32 terminals; resin based; body 7 × 7 × 0.8 mm	SOT1152-1
ADC1213S105HN/C1	105	HVQFN32R	plastic thermal enhanced very thin quad flat package; no leads; 32 terminals; resin based; body 7 × 7 × 0.8 mm	SOT1152-1
ADC1213S080HN/C1	80	HVQFN32R	plastic thermal enhanced very thin quad flat package; no leads; 32 terminals; resin based; body 7 × 7 × 0.8 mm	SOT1152-1
ADC1213S065HN/C1	65	HVQFN32R	plastic thermal enhanced very thin quad flat package; no leads; 32 terminals; resin based; body 7 × 7 × 0.8 mm	SOT1152-1

5. Block diagram

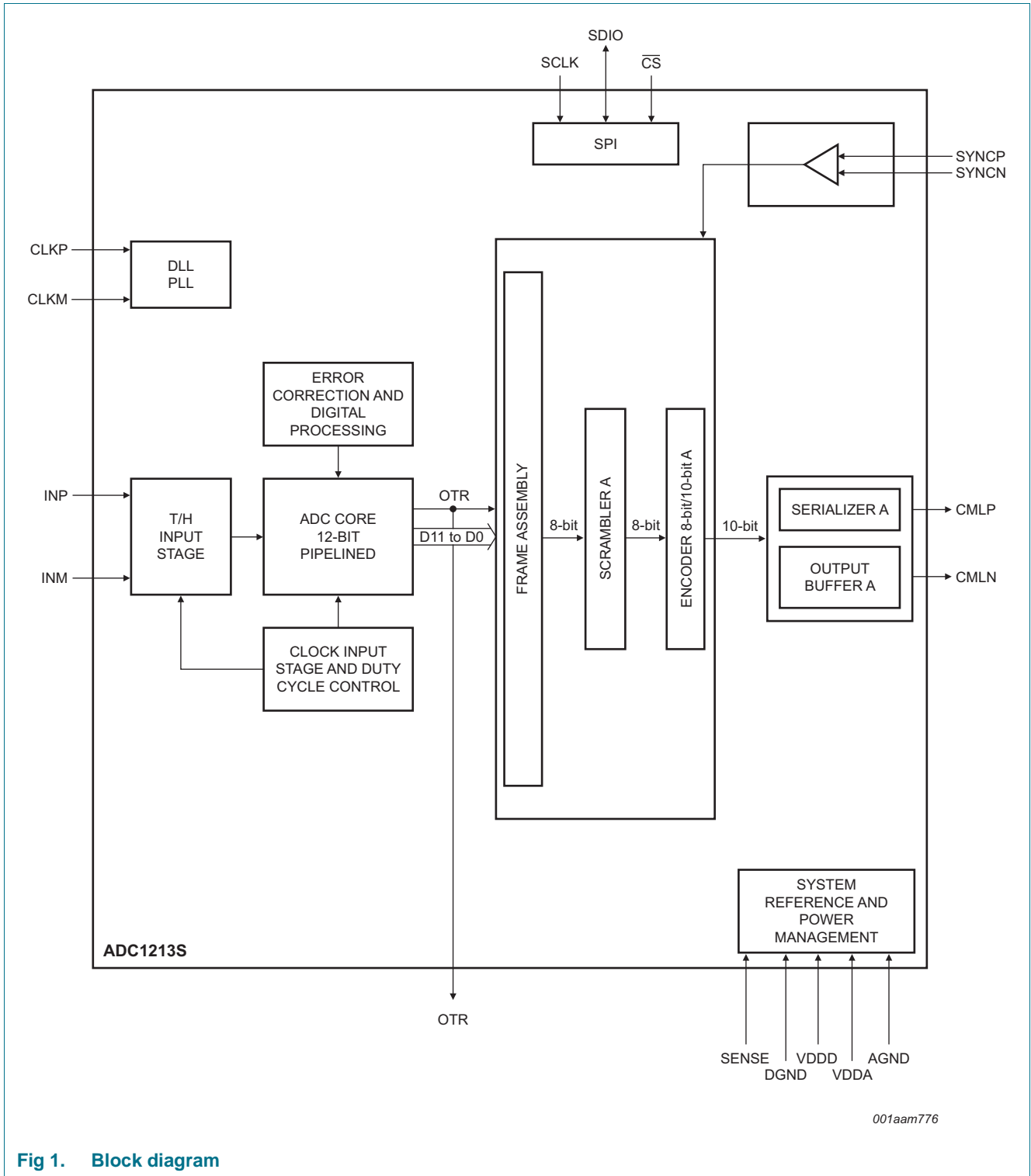

Fig 1. Block diagram

## 6. Pinning information

### 6.1 Pinning

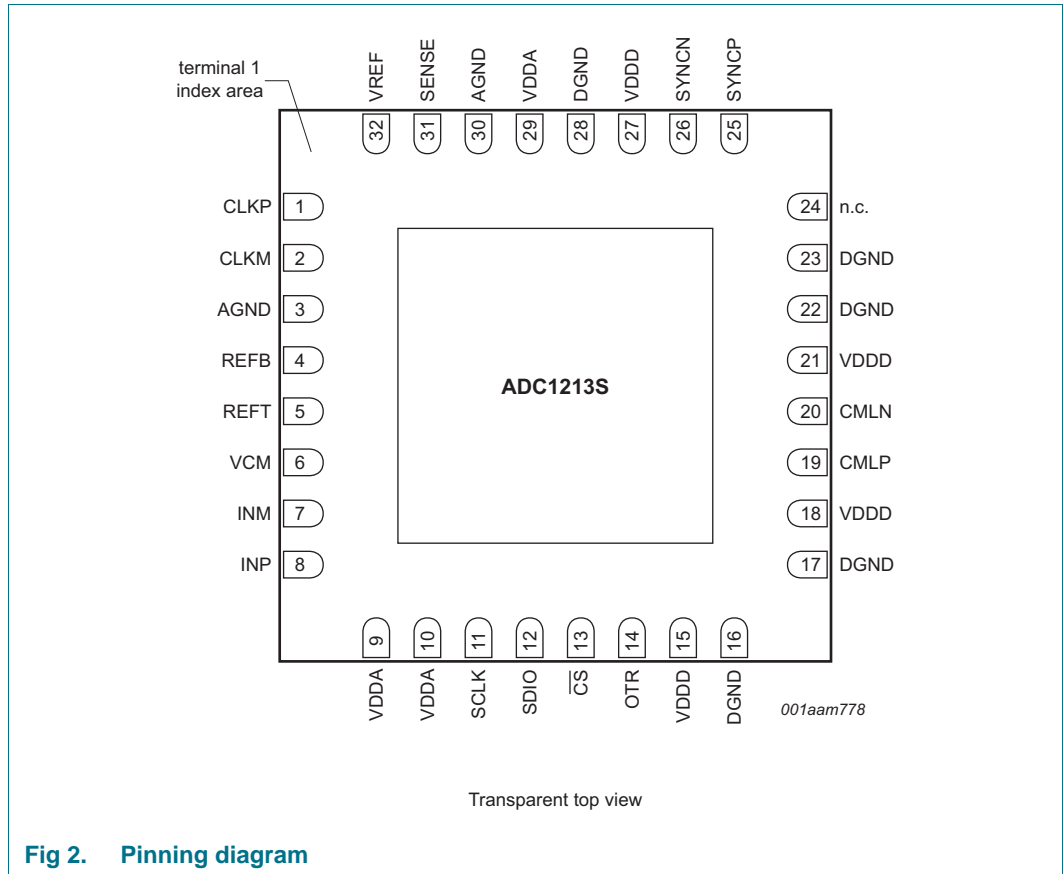

Fig 2. Pinning diagram

### 6.2 Pin description

Table 2. Pin description

Symbol	Pin	Type <sup>[1]</sup>	Description
CLKP	1	I	clock input
CLKM	2	I	complementary clock input
AGND	3	G	analog ground
REFB	4	O	ADC bottom reference
REFT	5	O	ADC top reference
VCM	6	O	ADC output common voltage
INM	7	I	ADC complementary analog input
INP	8	I	ADC analog input
VDDA	9	P	analog power supply 3 V
VDDA	10	P	analog power supply 3 V
SCLK	11	I	SPI clock
SDIO	12	I/O	SPI data input/output

Table 2. Pin description ...continued

Symbol	Pin	Type <sup>[1]</sup>	Description
$\overline{\text{CS}}$	13	I	chip select
OTR	14	O	out-of-range information
VDDD	15	P	digital power supply 1.8 V
DGND	16	G	digital ground
DGND	17	G	digital ground
VDDD	18	P	digital power supply 1.8 V
CMLP	19	O	serial output
CMLN	20	O	serial complementary output
VDDD	21	P	digital power supply 1.8 V
DGND	22	G	digital ground
DGND	23	G	digital ground
n.c.	24	-	not connected
SYNCP	25	I	positive synchronization signal from the receiver
SYNCP	26	I	negative synchronization signal from the receiver
VDDD	27	P	digital power supply 1.8 V
DGND	28	G	digital ground
VDDA	29	P	analog power supply 3 V
AGND	30	G	analog ground
SENSE	31	I	reference programming pin
VREF	32	I/O	voltage reference input/output

[1] P: power supply; G: ground; I: input; O: output; I/O: input/output.

## 7. Limiting values

Table 3. Limiting values

In accordance with the Absolute Maximum Rating System (IEC 60134).

Symbol	Parameter	Conditions	Min	Max	Unit
$V_{\text{DDA}}$	analog supply voltage		-0.4	+4.6	V
$V_{\text{DDD}(1\text{V}8)}$	digital supply voltage (1.8 V)		-0.4	+2.5	V
$T_{\text{stg}}$	storage temperature		-55	+125	°C
$T_{\text{amb}}$	ambient temperature		-40	+85	°C
$T_{\text{j}}$	junction temperature		-	125	°C

## 8. Thermal characteristics

Table 4. Thermal characteristics

Symbol	Parameter	Conditions	Typ	Unit
$R_{\text{th}(j-a)}$	thermal resistance from junction to ambient	[1]	25.6	K/W
$R_{\text{th}(j-c)}$	thermal resistance from junction to case	[1]	8.6	K/W

[1] Value for six layers board in still air with a minimum of 25 thermal vias.

## 9. Static characteristics

Table 5. Static characteristics [\[1\]](#)

Symbol	Parameter	Conditions	Min	Typ	Max	Unit
<b>Supplies</b>						
$V_{DDA}$	analog supply voltage		2.85	3.0	3.4	V
$V_{DDD(1V8)}$	digital supply voltage (1.8 V)		1.65	1.8	1.95	V
$I_{DDA}$	analog supply current	$f_{clk} = 125$ Msps; $f_i = 70$ MHz	-	185	-	mA
$I_{DDD(1V8)}$	digital supply current (1.8 V)	$f_{clk} = 125$ Msps; $f_i = 70$ MHz	-	75	-	mA
$P_{tot}$	total power dissipation	$f_{clk} = 125$ Msps	-	690	-	mW
		$f_{clk} = 105$ Msps	-	625	-	mW
		$f_{clk} = 80$ Msps	-	550	-	mW
		$f_{clk} = 65$ Msps	-	495	-	mW
P	power dissipation	Power-down mode	-	30	-	mW
		Standby mode	-	150	-	mW
<b>Clock inputs: pins CLKP and CLKM (AC-coupled)</b>						
<b>Low-Voltage Positive Emitter-Coupled Logic (LVPECL)</b>						
$V_{i(clk)dif}$	differential clock input voltage	peak-to-peak	-	1.6	-	V
<b>SINE</b>						
$V_{i(clk)dif}$	differential clock input voltage	peak	$\pm 0.8$	$\pm 3.0$	-	V
<b>Low Voltage Complementary Metal Oxide Semiconductor (LVCMOS)</b>						
$V_{IL}$	LOW-level input voltage		-	-	$0.3V_{DDA}$	V
$V_{IH}$	HIGH-level input voltage		$0.7V_{DDA}$	-	-	V
<b>SPI: pins CS, SDIO, and SCLK</b>						
$V_{IL}$	LOW-level input voltage		0	-	$0.3V_{DDA}$	V
$V_{IH}$	HIGH-level input voltage		$0.7V_{DDA}$	-	$V_{DDA}$	V
$I_{IL}$	LOW-level input current		-10	-	+10	$\mu$ A
$I_{IH}$	HIGH-level input current		-50	-	+50	$\mu$ A
$C_i$	input capacitance		-	4	-	pF
<b>Analog inputs: pins INP and INM</b>						
$I_i$	input current	track mode	-5	-	+5	$\mu$ A
$R_i$	input resistance	track mode	-	15	-	$\Omega$
$C_i$	input capacitance	track mode	-	5	-	pF
$V_{i(cm)}$	common-mode input voltage	track mode	1.1	1.5	2	V
$B_i$	input bandwidth		-	600	-	MHz
$V_{i(dif)}$	differential input voltage	peak-to-peak	1	-	2	V

Table 5. Static characteristics ...continued<sup>[1]</sup>

Symbol	Parameter	Conditions	Min	Typ	Max	Unit
<b>Voltage controlled regulator output: pin VCM</b>						
$V_{O(cm)}$	common-mode output voltage		-	$0.5V_{DDA}$	-	V
$I_{O(cm)}$	common-mode output current		-	4	-	mA
<b>Reference voltage input/output: pin VREF</b>						
$V_{VREF}$	voltage on pin VREF	output	0.5	-	1	V
		input	0.5	-	1	V
<b>Data outputs: pins CMLP, CMLN</b>						
Output levels, $V_{DD(1V8)} = 1.8\text{ V}$ ; $SWING\_SEL[2:0] = 000$						
$V_{OL}$	LOW-level output voltage	DC-coupled; output	-	1.5	-	V
		AC-coupled	-	1.35	-	V
$V_{OH}$	HIGH-level output voltage	DC-coupled; output	-	1.8	-	V
		AC-coupled	-	1.65	-	V
Output levels, $V_{DD(1V8)} = 1.8\text{ V}$ ; $SWING\_SEL[2:0] = 001$						
$V_{OL}$	LOW-level output voltage	DC-coupled; output	-	1.45	-	V
		AC-coupled	-	1.275	-	V
$V_{OH}$	HIGH-level output voltage	DC-coupled; output	-	1.8	-	V
		AC-coupled	-	1.625	-	V
Output levels, $V_{DD(1V8)} = 1.8\text{ V}$ ; $SWING\_SEL[2:0] = 010$						
$V_{OL}$	LOW-level output voltage	DC-coupled; output	-	1.4	-	V
		AC-coupled	-	1.2	-	V
$V_{OH}$	HIGH-level output voltage	DC-coupled; output	-	1.8	-	V
		AC-coupled	-	1.6	-	V
Output levels, $V_{DD(1V8)} = 1.8\text{ V}$ ; $SWING\_SEL[2:0] = 011$						
$V_{OL}$	LOW-level output voltage	DC-coupled; output	-	1.35	-	V
		AC-coupled	-	1.125	-	V
$V_{OH}$	HIGH-level output voltage	DC-coupled; output	-	1.8	-	V
		AC-coupled	-	1.575	-	V
Output levels, $V_{DD(1V8)} = 1.8\text{ V}$ ; $SWING\_SEL[2:0] = 100$						
$V_{OL}$	LOW-level output voltage	DC-coupled; output	-	1.3	-	V
		AC-coupled	-	1.05	-	V
$V_{OH}$	HIGH-level output voltage	DC-coupled; output	-	1.8	-	V
		AC-coupled	-	1.55	-	V
<b>Serial configuration: pins SYNC_P, SYNC_N</b>						
$V_{IL}$	LOW-level input voltage	differential; input	-	0.95	-	V
$V_{IH}$	HIGH-level input voltage	differential; input	-	1.47	-	V
<b>Accuracy</b>						
INL	integral non-linearity		-5	-	+5	LSB
DNL	differential non-linearity	guaranteed no missing codes	-0.95	$\pm 0.5$	+0.95	LSB
$E_{offset}$	offset error		-	$\pm 2$	-	mV

Table 5. Static characteristics ...continued<sup>[1]</sup>

Symbol	Parameter	Conditions	Min	Typ	Max	Unit
$E_G$	gain error	full-scale	-	$\pm 0.5$	-	%
<b>Supply</b>						
PSRR	power supply rejection ratio	200 mV (p-p) on pin VDDA; $f_i = \text{DC}$	-	-54	-	dB

[1] Typical values measured at  $V_{DDA} = 3 \text{ V}$ ,  $V_{DDD(1V8)} = 1.8 \text{ V}$ ,  $T_{\text{amb}} = 25 \text{ }^\circ\text{C}$ . Minimum and maximum values are across the full temperature range  $T_{\text{amb}} = -40 \text{ }^\circ\text{C}$  to  $+85 \text{ }^\circ\text{C}$  at  $V_{DDA} = 3 \text{ V}$ ,  $V_{DDD(1V8)} = 1.8 \text{ V}$ ;  $V_{i(\text{INP})} - V_{i(\text{INM})} = -1 \text{ dBFS}$ ; internal reference mode;  $100 \text{ } \Omega$  differential applied to serial outputs; unless otherwise specified.

## 10. Dynamic characteristics

### 10.1 Dynamic characteristics

Table 6. Dynamic characteristics [1]

Symbol	Parameter	Conditions	ADC1213S065			ADC1213S080			ADC1213S105			ADC1213S125			Unit
			Min	Typ	Max	Min	Typ	Max	Min	Typ	Max	Min	Typ	Max	
$\alpha_{2H}$	second harmonic level	$f_i = 3$ MHz	-	87	-	-	87	-	-	86	-	-	88	-	dBc
		$f_i = 30$ MHz	-	86	-	-	86	-	-	86	-	-	87	-	dBc
		$f_i = 70$ MHz	-	85	-	-	85	-	-	84	-	-	85	-	dBc
		$f_i = 170$ MHz	-	82	-	-	82	-	-	81	-	-	83	-	dBc
$\alpha_{3H}$	third harmonic level	$f_i = 3$ MHz	-	86	-	-	86	-	-	85	-	-	87	-	dBc
		$f_i = 30$ MHz	-	85	-	-	85	-	-	85	-	-	86	-	dBc
		$f_i = 70$ MHz	-	84	-	-	84	-	-	83	-	-	84	-	dBc
		$f_i = 170$ MHz	-	81	-	-	81	-	-	80	-	-	82	-	dBc
THD	total harmonic distortion	$f_i = 3$ MHz	-	83	-	-	83	-	-	82	-	-	84	-	dBc
		$f_i = 30$ MHz	-	82	-	-	82	-	-	82	-	-	83	-	dBc
		$f_i = 70$ MHz	-	81	-	-	81	-	-	80	-	-	81	-	dBc
		$f_i = 170$ MHz	-	78	-	-	78	-	-	77	-	-	79	-	dBc
ENOB	effective number of bits	$f_i = 3$ MHz	-	11.3	-	-	11.3	-	-	11.3	-	-	11.3	-	bits
		$f_i = 30$ MHz	-	11.3	-	-	11.3	-	-	11.3	-	-	11.2	-	bits
		$f_i = 70$ MHz	-	11.2	-	-	11.2	-	-	11.2	-	-	11.2	-	bits
		$f_i = 170$ MHz	-	11.1	-	-	11.1	-	-	11.1	-	-	11.1	-	bits
SNR	signal-to-noise ratio	$f_i = 3$ MHz	-	70.0	-	-	69.9	-	-	69.8	-	-	69.6	-	dBFS
		$f_i = 30$ MHz	-	69.5	-	-	69.5	-	-	69.5	-	-	69.4	-	dBFS
		$f_i = 70$ MHz	-	69.2	-	-	69.2	-	-	69.1	-	-	60.0	-	dBFS
		$f_i = 170$ MHz	-	68.8	-	-	68.8	-	-	68.7	-	-	68.6	-	dBFS
SFDR	spurious-free dynamic range	$f_i = 3$ MHz	-	86	-	-	86	-	-	85	-	-	87	-	dBc
		$f_i = 30$ MHz	-	85	-	-	85	-	-	85	-	-	86	-	dBc
		$f_i = 70$ MHz	-	84	-	-	84	-	-	83	-	-	84	-	dBc
		$f_i = 170$ MHz	-	81	-	-	81	-	-	80	-	-	82	-	dBc

Table 6. Dynamic characteristics ...continued [1]

Symbol	Parameter	Conditions	ADC1213S065			ADC1213S080			ADC1213S105			ADC1213S125			Unit
			Min	Typ	Max	Min	Typ	Max	Min	Typ	Max	Min	Typ	Max	
IMD	intermodulation distortion	$f_i = 3$ MHz	-	89	-	-	89	-	-	88	-	-	89	-	dBc
		$f_i = 30$ MHz	-	88	-	-	88	-	-	88	-	-	88	-	dBc
		$f_i = 70$ MHz	-	87	-	-	87	-	-	86	-	-	86	-	dBc
		$f_i = 170$ MHz	-	84	-	-	85	-	-	83	-	-	84	-	dBc
$\alpha_{ct(ch)}$	channel crosstalk	$f_i = 70$ MHz	-	100	-	-	100	-	-	100	-	-	100	-	dBc

[1] Typical values measured at  $V_{DDA} = 3$  V,  $V_{DDD(1V8)} = 1.8$  V,  $T_{amb} = 25$  °C. Minimum and maximum values are across the full temperature range  $T_{amb} = -40$  °C to  $+85$  °C at  $V_{DDA} = 3$  V,  $V_{DDD(1V8)} = 1.8$  V;  $V_{i(INP)} - V_{i(INM)} = -1$  dBFS; internal reference mode; 100  $\Omega$  differential applied to serial outputs; unless otherwise specified.

## 10.2 Clock and digital output timing

Table 7. Clock and digital output characteristics [1]

Symbol	Parameter	Conditions	ADC1213S065			ADC1213S080			ADC1213S105			ADC1213S125			Unit
			Min	Typ	Max	Min	Typ	Max	Min	Typ	Max	Min	Typ	Max	
<b>pins CLKP and CLKM</b>															
$f_{clk}$	clock frequency		45	-	65	60	-	80	75	-	105	100	-	125	Msp/s
$t_{lat(data)}$	data latency time	clock cycles	307	-	850	250	-	283	190	-	226	160	-	170	ns
$\delta_{clk}$	clock duty cycle	DCS_EN = logic 1	30	50	70	30	50	70	30	50	70	30	50	70	%
$t_{d(s)}$	sampling delay time		-	0.8	-	-	0.8	-	-	0.8	-	-	0.8	-	ns
$t_{wake}$	wake-up time		-	76	-	-	76	-	-	76	-	-	76	-	$\mu$ s

[1] Typical values measured at  $V_{DDA} = 3$  V,  $V_{DDD(1V8)} = 1.8$  V,  $T_{amb} = 25$  °C. Minimum and maximum values are across the full temperature range  $T_{amb} = -40$  °C to  $+85$  °C at  $V_{DDA} = 3$  V,  $V_{DDD(1V8)} = 1.8$  V;  $V_{i(INP)} - V_{i(INM)} = -1$  dBFS; internal reference mode; 100  $\Omega$  differential applied to serial outputs; unless otherwise specified.

### 10.3 Serial output timing

The eye diagram of the serial output is shown in [Figure 3](#) and [Figure 4](#). Test conditions are:

- 3.125 Gbps data rate
- $T_{amb} = 25\text{ }^{\circ}\text{C}$
- DC-coupling with two different receiver common-mode voltages

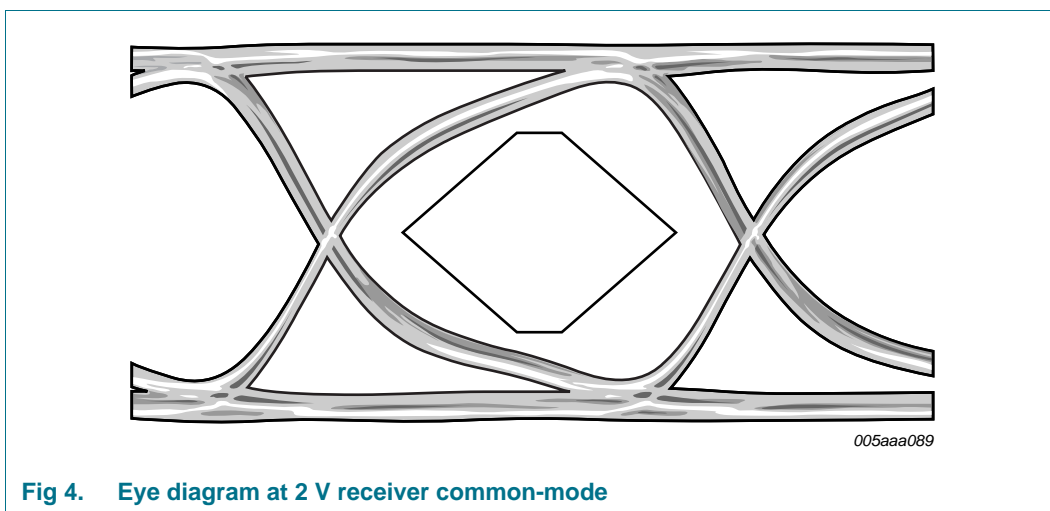
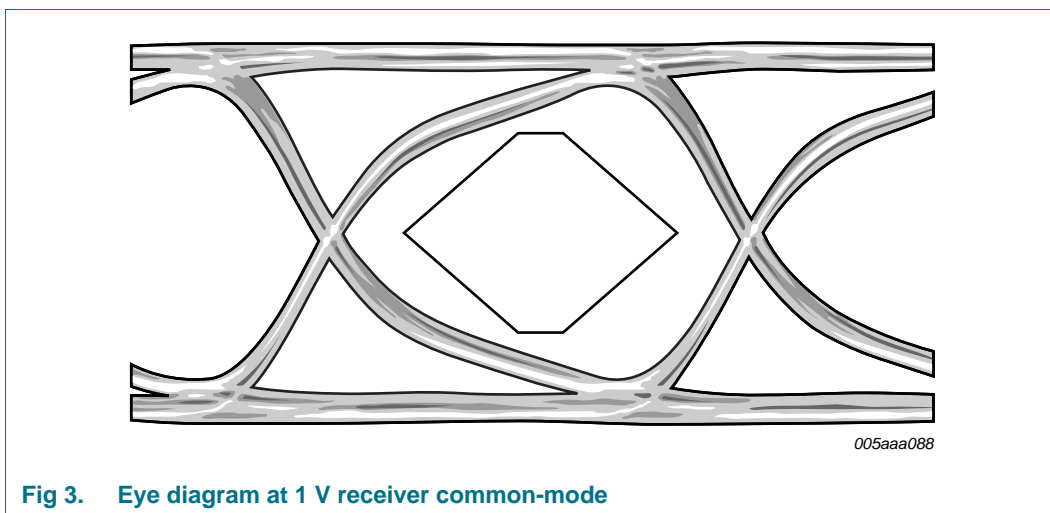

10.4 SPI timing

Table 8. SPI timing characteristics [1]

Symbol	Parameter	Conditions	Min	Typ	Max	Unit
$t_{w(SCLK)}$	SCLK pulse width		-	40	-	ns
$t_{w(SCLKH)}$	SCLK HIGH pulse width		-	16	-	ns
$t_{w(SCLKL)}$	SCLK LOW pulse width		-	16	-	ns
$t_{su}$	set-up time	data to SCLK HIGH	-	5	-	ns
		$\overline{CS}$ to SCLK HIGH	-	5	-	ns
$t_h$	hold time	data to SCLK HIGH	-	2	-	ns
		$\overline{CS}$ to SCLK HIGH	-	2	-	ns
$f_{clk(max)}$	maximum clock frequency		-	25	-	MHz

[1] Typical values measured at  $V_{DDA} = 3\text{ V}$ ,  $V_{DDD(1V8)} = 1.8\text{ V}$ ,  $T_{amb} = 25\text{ }^\circ\text{C}$ . Minimum and maximum values are across the full temperature range  $T_{amb} = -40\text{ }^\circ\text{C}$  to  $+85\text{ }^\circ\text{C}$  at  $V_{DDA} = 3\text{ V}$ ,  $V_{DDD(1V8)} = 1.8\text{ V}$ ;  $V_{i(INP)} - V_{i(INM)} = -1\text{ dBFS}$ ; internal reference mode;  $100\text{ }\Omega$  differential applied to serial outputs; unless otherwise specified.

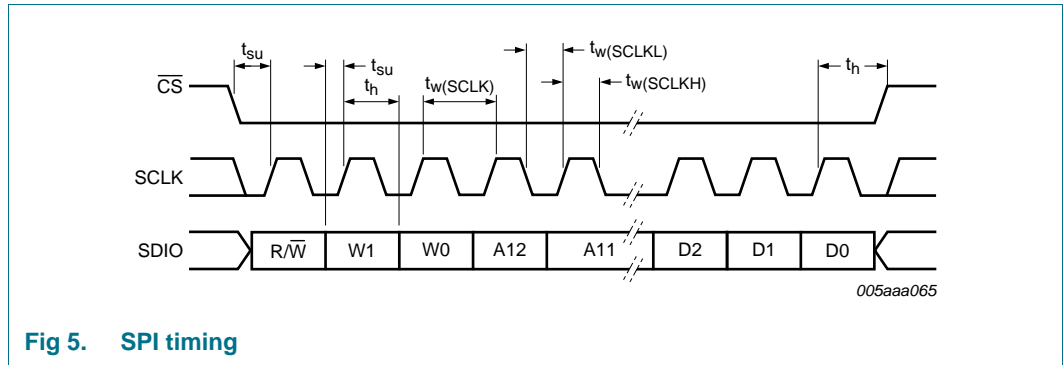

Fig 5. SPI timing

## 11. Application information

### 11.1 Analog inputs

#### 11.1.1 Input stage description

The analog input of the ADC1213S supports a differential or a single-ended input drive. Optimal performance is achieved using differential inputs with the common-mode input voltage ( $V_{I(cm)}$ ) on pins INP and INM set to  $0.5V_{DDA}$ .

The full-scale analog input voltage range is configurable between 1 V (p-p) and 2 V (p-p) via a programmable internal reference (see [Section 11.2](#) and [Table 21](#)).

[Figure 6](#) shows the equivalent circuit of the sample-and-hold input stage, including ElectroStatic Discharge (ESD) protection and circuit and package parasitics.

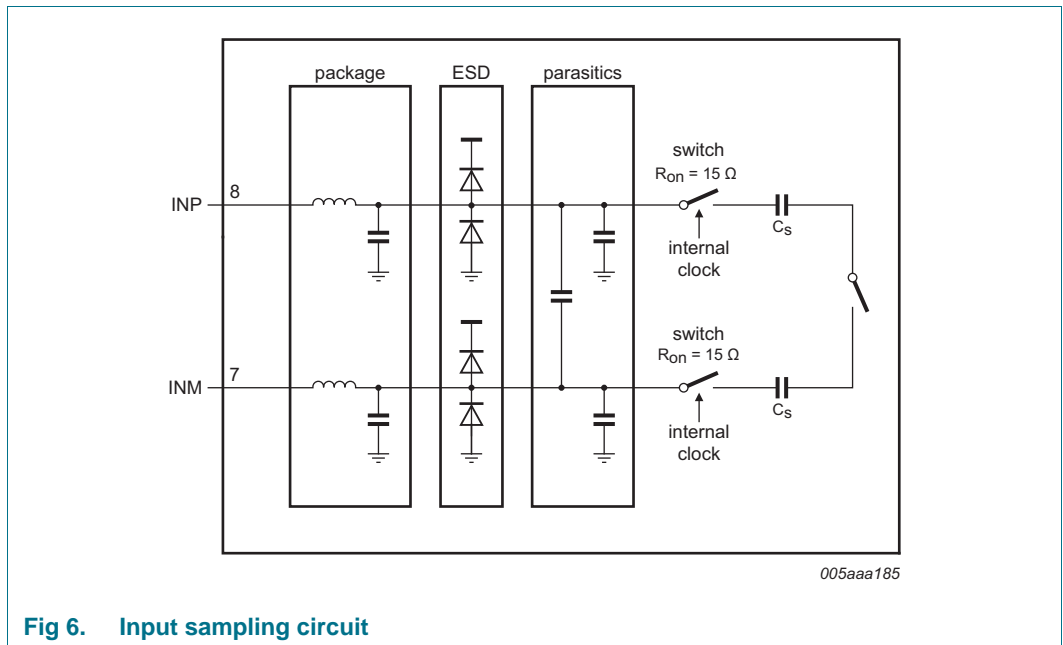

**Fig 6. Input sampling circuit**

The sample phase occurs when the internal clock (derived from the clock signal on pin CLKP/CLKM) is HIGH. The voltage is then held on the sampling capacitors. When the clock signal goes LOW, the stage enters the hold phase and the voltage information is transmitted to the ADC core.

#### 11.1.2 Anti-kickback circuitry

Anti-kickback circuitry (RC filter in [Figure 7](#)) is needed to counteract the effects of a charge injection generated by the sampling capacitance.

The RC filter is also used to filter noise from the signal before it reaches the sampling stage. The value of the capacitor should be chosen to maximize noise attenuation without degrading the settling time excessively.

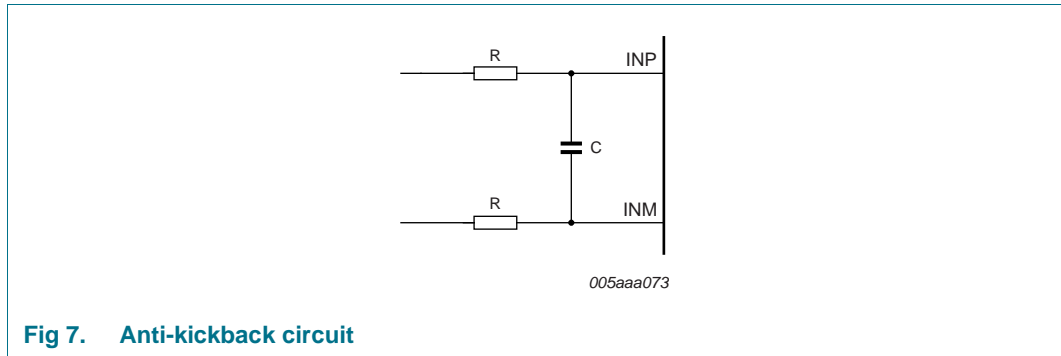

Fig 7. Anti-kickback circuit

The component values are determined by the input frequency and should be selected so as not to affect the input bandwidth.

Table 9. RC-coupling versus input frequency, typical values

Input frequency (MHz)	Resistance ( $\Omega$ )	Capacitance (pF)
3	25	12
70	12	8
170	12	8

11.1.3 Transformer

The configuration of the transformer circuit is determined by the input frequency. The configuration shown in Figure 8 would be suitable for a baseband application.

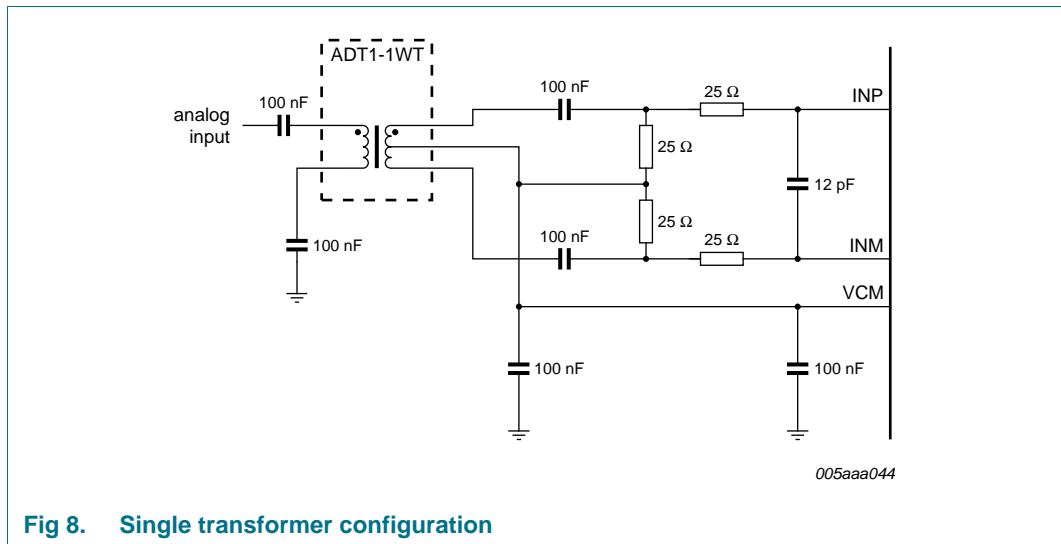
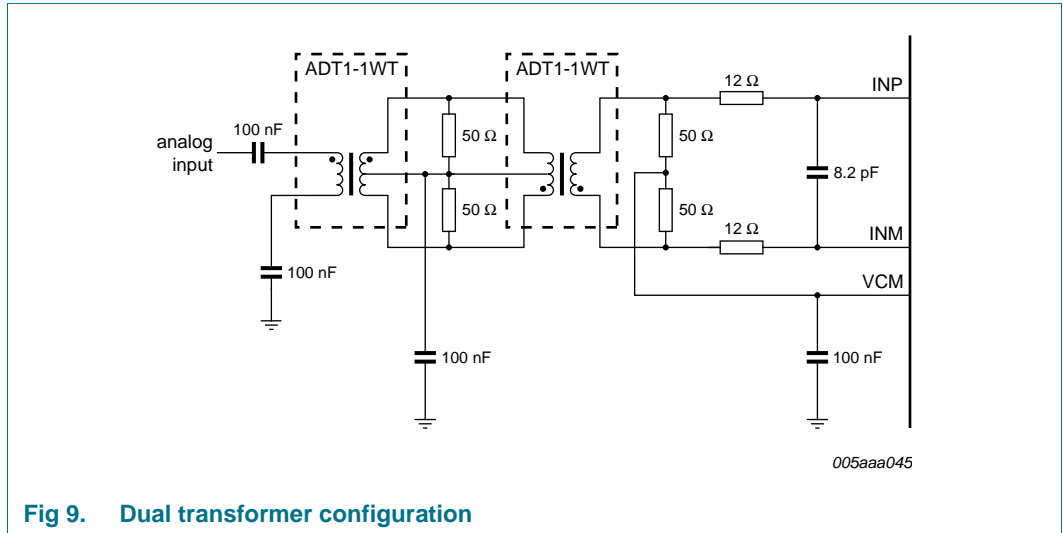

Fig 8. Single transformer configuration

The configuration shown in [Figure 9](#) is recommended for high frequency applications. In both cases, the choice of transformer is a compromise between cost and performance.



## 11.2 System reference and power management

### 11.2.1 Internal/external reference

The ADC1213S has a stable and accurate built-in internal reference voltage to adjust the ADC full-scale. This reference voltage can be set internally via SPI or with pins VREF and SENSE (see [Figure 11](#) to [Figure 14](#)), in 1 dB steps between 0 dB and -6 dB, via SPI control bits INTREF[2:0] (when bit INTREF\_EN = logic 1; see [Table 21](#)). The equivalent reference circuit is shown in [Figure 10](#). An external reference is also possible by providing a voltage on pin VREF as described in [Figure 14](#).

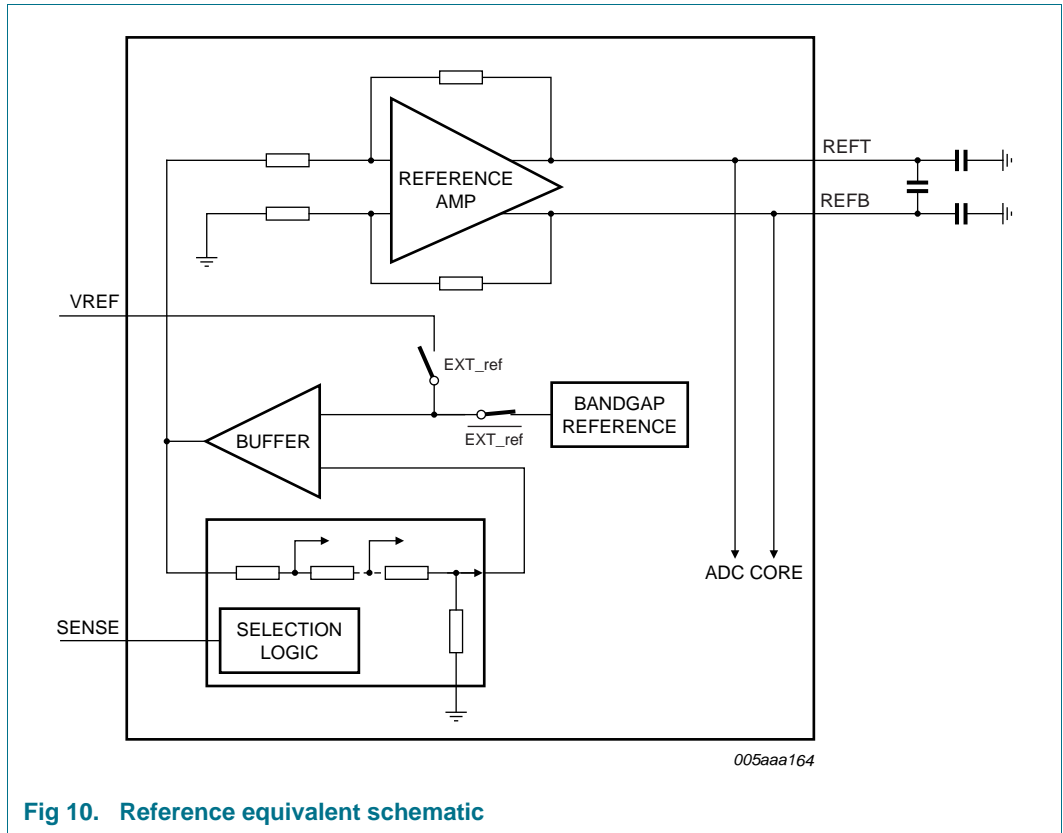

Fig 10. Reference equivalent schematic

If bit INTREF\_EN is set to logic 0, the reference voltage is determined either internally or externally as detailed in Table 10.

Table 10. Reference modes

Mode	SPI bit, "Internal reference"	SENSE pin	VREF pin	Full-scale, (V (p-p))
Internal (Figure 11)	0	GND	330 pF capacitor to GND	2
Internal (Figure 12)	0	VREF pin = SENSE pin and 330 pF capacitor to GND		1
Internal, SPI mode (Figure 13)	1	VREF pin = SENSE pin and 330 pF capacitor to GND		1 to 2
External (Figure 14)	0	V <sub>DDA</sub>	external voltage from 0.5 V to 1 V	1 to 2

Figure 11 to Figure 14 illustrate how to connect the SENSE and VREF pins to select the required reference voltage source.

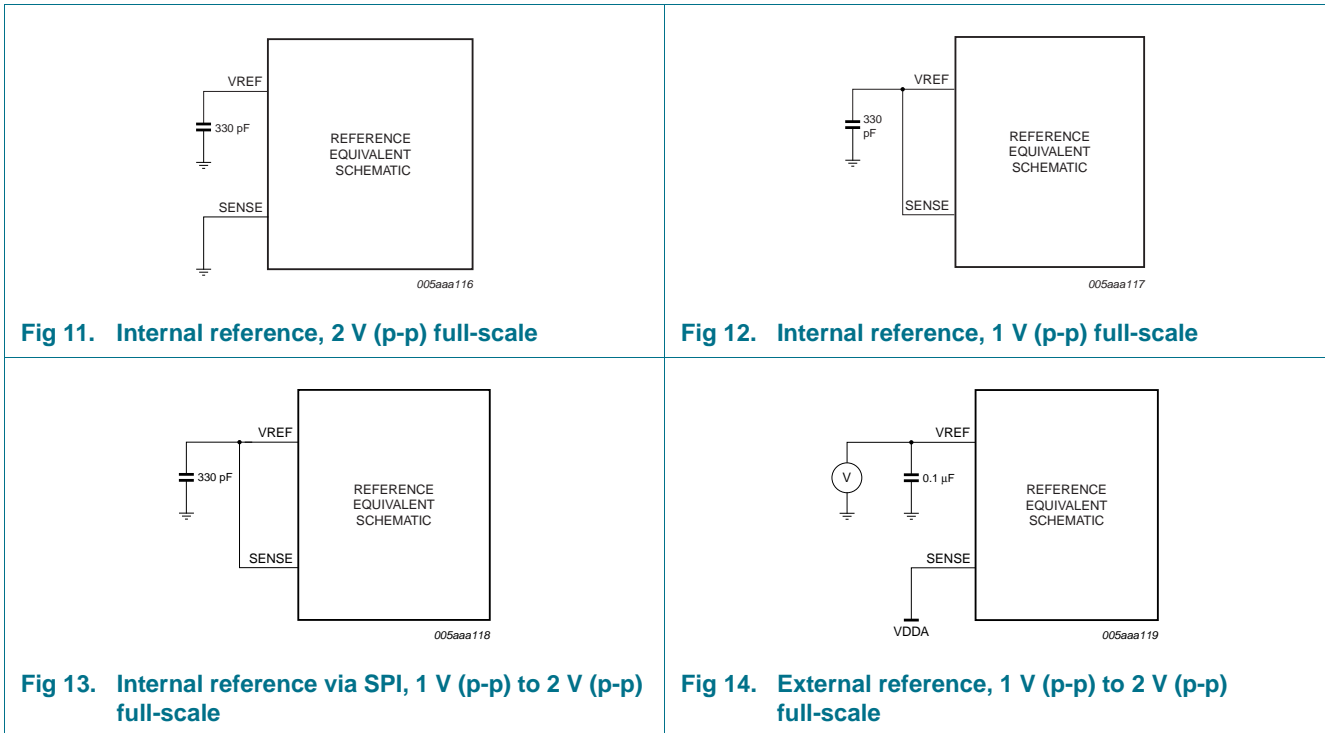

### 11.2.2 Programmable full-scale

The full-scale is programmable between 1 V (p-p) to 2 V (p-p) (see [Table 11](#)).

Table 11. Reference SPI gain control

INTREF[2:0]	Level (dB)	Full-scale (V (p-p))
000	0	2
001	-1	1.78
010	-2	1.59
011	-3	1.42
100	-4	1.26
101	-5	1.12
110	-6	1
111	not used	x

### 11.2.3 Common-mode output voltage ( $V_{O(cm)}$ )

An 0.1  $\mu$ F filter capacitor should be connected between pin VCM and ground to ensure a low-noise common-mode output voltage. When AC-coupled, this pin can be used to set the common-mode reference for the analog inputs, for instance via a transformer middle point.



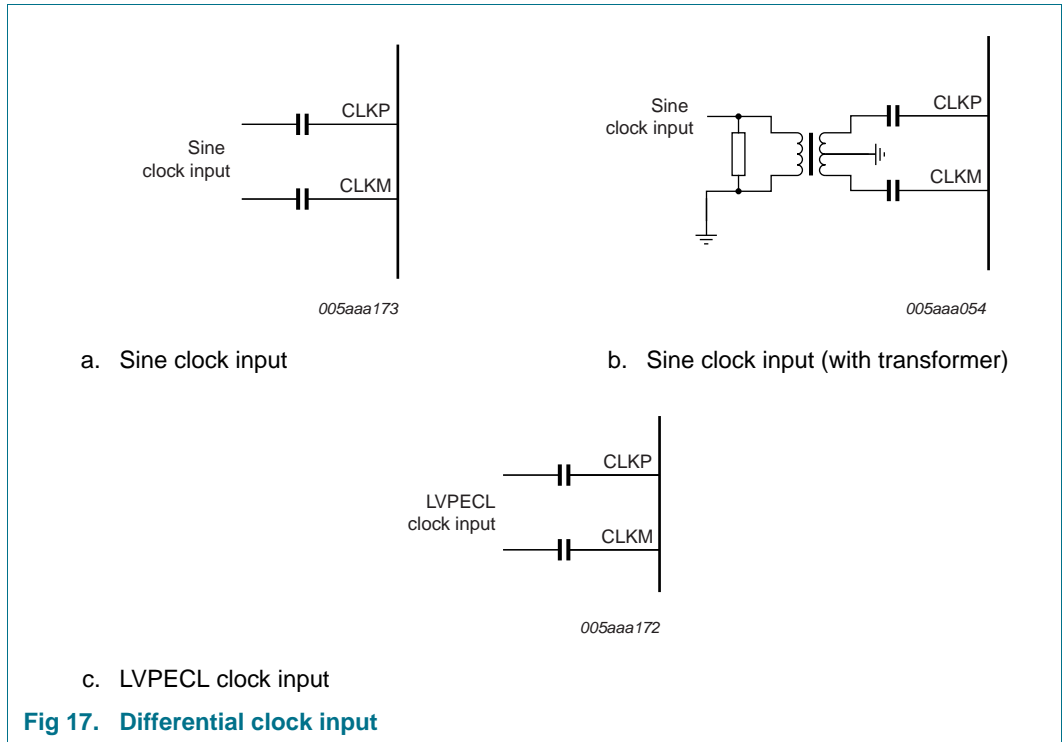

### 11.3.2 Equivalent input circuit

The equivalent circuit of the input clock buffer is shown in [Figure 18](#). The common-mode voltage of the differential input stage is set via internal 5 kΩ resistors.

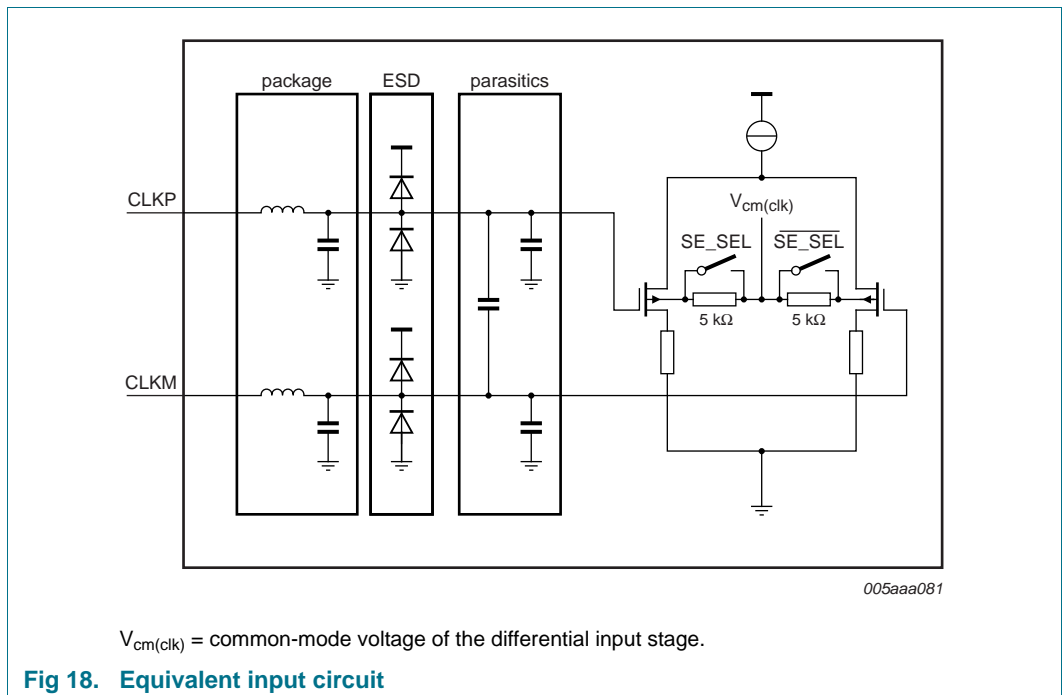

Single-ended or differential clock inputs can be selected via the SPI (see [Table 20](#)). If single-ended is selected, the input pin (CLKM or CLKP) is selected via control bit SE\_SEL.

If single-ended is implemented without setting bit SE\_SEL accordingly, the unused pin should be connected to ground via a capacitor.

**11.3.3 Duty cycle stabilizer**

The duty cycle stabilizer can improve the overall performance of the ADC by compensating the input clock signal duty cycle. When the duty cycle stabilizer is active (bit DCS\_EN = logic 1; see [Table 20](#)), the circuit can handle signals with duty cycles of between 30 % and 70 % (typical). When the duty cycle stabilizer is disabled (DCS\_EN = logic 0), the input clock signal should have a duty cycle of between 45 % and 55 %.

**Table 12. Duty cycle stabilizer**

bit DCS_EN	Description
0	duty cycle stabilizer disable
1	duty cycle stabilizer enable

**11.3.4 Clock input divider**

The ADC1213S contains an input clock divider that divides the incoming clock by a factor of 2 (when bit CLKDIV2\_SEL = logic 1; see [Table 20](#)). This feature allows the user to deliver a higher clock frequency with better jitter performance, leading to a better SNR result once acquisition has been performed.

**11.4 Digital outputs**

**11.4.1 Serial output equivalent circuit**

The JESD204A standard specifies that if the receiver and the transmitter are DC-coupled, both must be fed from the same supply.

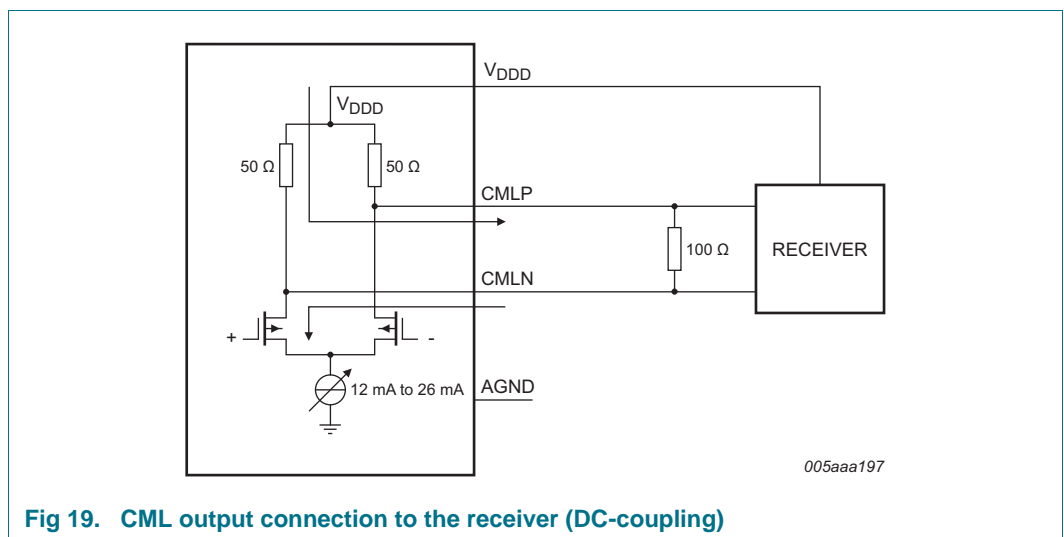

**Fig 19. CML output connection to the receiver (DC-coupling)**

The output should be terminated when 100 Ω (typical) is reached at the receiver side.

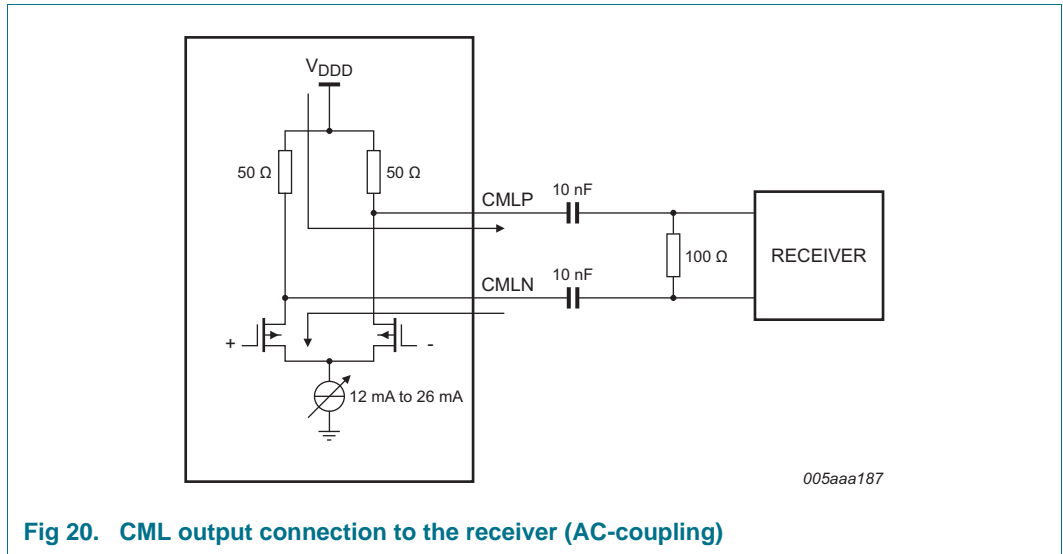

Fig 20. CML output connection to the receiver (AC-coupling)

### 11.5 JESD204A serializer

For more information about the JESD204A standard refer to the JEDEC web site.

#### 11.5.1 Digital JESD204A formatter

The block placed after the ADC core is used to implement all functions of the JESD204A standard. This ensures signal integrity and guarantees the clock and the data recovery at the receiver side.

The block is highly parameterized and can be configured in various ways depending on the sampling frequency and the number of lanes used.

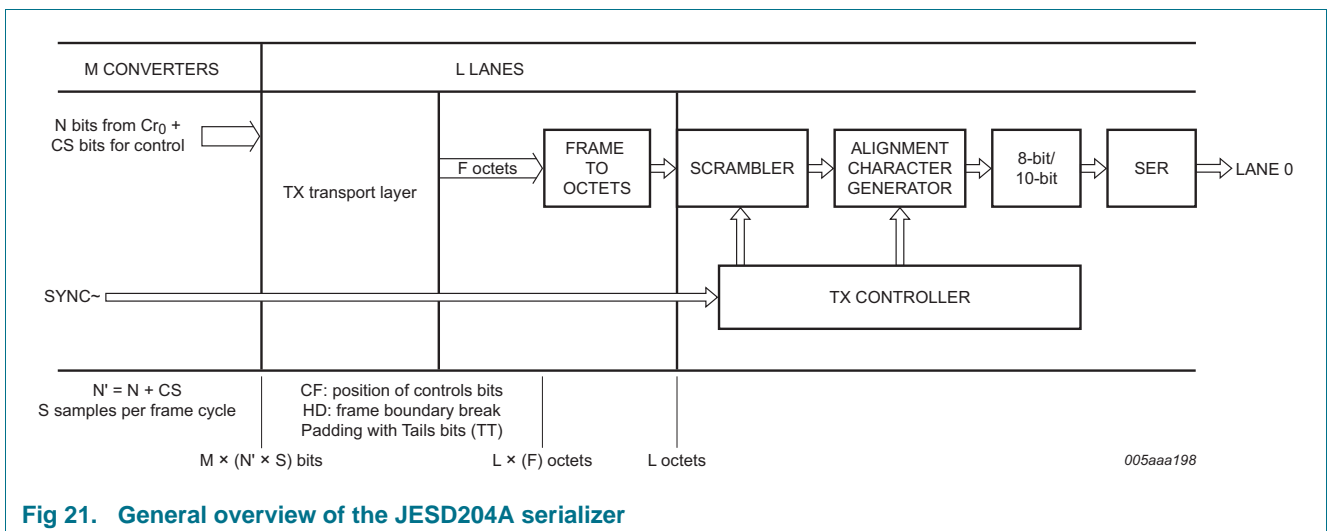

Fig 21. General overview of the JESD204A serializer

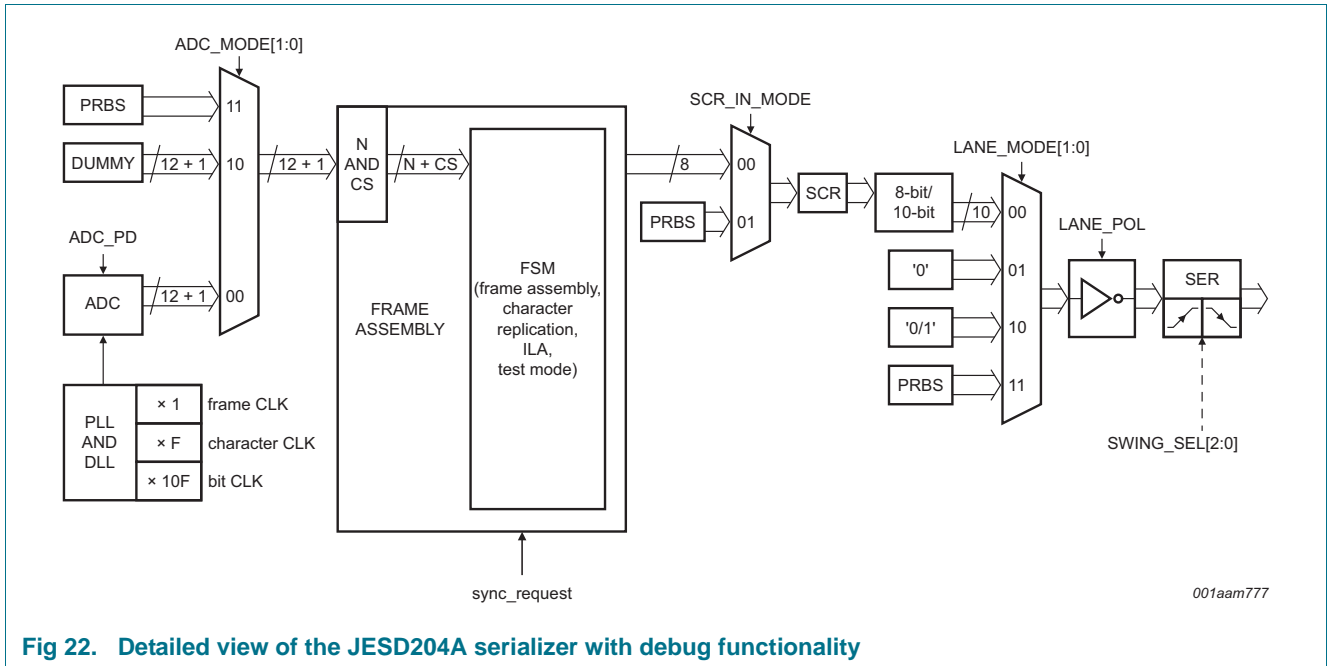

Fig 22. Detailed view of the JESD204A serializer with debug functionality

11.5.2 ADC core output codes versus input voltage

Table 13 shows the data output codes for a given analog input voltage.

Table 13. Output codes versus input voltage

INP-INM (V)	Offset binary	Two's complement	OTR
< -1	0000 0000 0000	1000 0000 0000	1
-1.0000000	0000 0000 0000	1000 0000 0000	0
-0.9995117	0000 0000 0001	1000 0000 0001	0
-0.9990234	0000 0000 0010	1000 0000 0010	0
-0.9985352	0000 0000 0011	1000 0000 0011	0
-0.9980469	0000 0000 0100	1000 0000 0100	0
....	....	....	0
-0.0009766	0111 1111 1110	1111 1111 1110	0
-0.0004883	0111 1111 1111	1111 1111 1111	0
0.0000000	1000 0000 0000	0000 0000 0000	0
+0.0004883	1000 0000 0001	0000 0000 0001	0
+0.0009766	1000 0000 0010	0000 0000 0010	0
....	....	....	0
+0.9980469	1111 1111 1011	0111 1111 1011	0
+0.9985352	1111 1111 1100	0111 1111 1100	0
+0.9990234	1111 1111 1101	0111 1111 1101	0
+0.9995117	1111 1111 1110	0111 1111 1110	0
+1.0000000	1111 1111 1111	0111 1111 1111	0
> +1	1111 1111 1111	0111 1111 1111	1

## 11.6 Serial Peripheral Interface (SPI)

### 11.6.1 Register description

The ADC1213S serial interface is a synchronous serial communications port allowing for easy interfacing with many industry microprocessors. It provides access to the registers that control the operation of the chip in both read and write modes.

This interface is configured as a 3-wire type (SDIO as bidirectional pin).

Pin SCLK acts as the serial clock and pin  $\overline{CS}$  acts as the serial chip select.

Each read/write operation is sequenced by the  $\overline{CS}$  signal and enabled by a LOW level to drive the chip with N bytes, depending on the content of the instruction byte (see [Table 14](#)).

**Table 14. Instruction bytes for the SPI**

	MSB							LSB
Bit	7	6	5	4	3	2	1	0
Description	R/W <sup>[1]</sup>	W1	W0	A12	A11	A10	A9	A8
	A7	A6	A5	A4	A3	A2	A1	A0

[1] R/W indicates whether a read (logic 1) or write (logic 0) transfer occurs after the instruction byte.

**Table 15. Read or Write mode access description**

R/W <sup>[1]</sup>	Description
0	Write mode operation
1	Read mode operation

[1] Bits W1 and W0 indicate the number of bytes transferred.

**Table 16. Number of bytes to be transferred**

W1	W0	Number of bytes transferred
0	0	1 byte
0	1	2 bytes
1	0	3 bytes
1	1	4 or more bytes

Bits A12 to A0 indicate the address of the register being accessed. In the case of a multiple byte transfer, this address is the first register to be accessed. An address counter is incremented to access subsequent addresses.

The steps involved in a data transfer are as follows:

1. The falling edge on pin  $\overline{CS}$  in combination with a rising edge on pin SCLK determine the start of communications.
2. The first phase is the transfer of the 2-byte instruction.
3. The second phase is the transfer of the data which can vary in length but is always a multiple of 8 bits. The MSB is always sent first (for instruction and data bytes).
4. A rising edge on pin  $\overline{CS}$  indicates the end of data transmission.

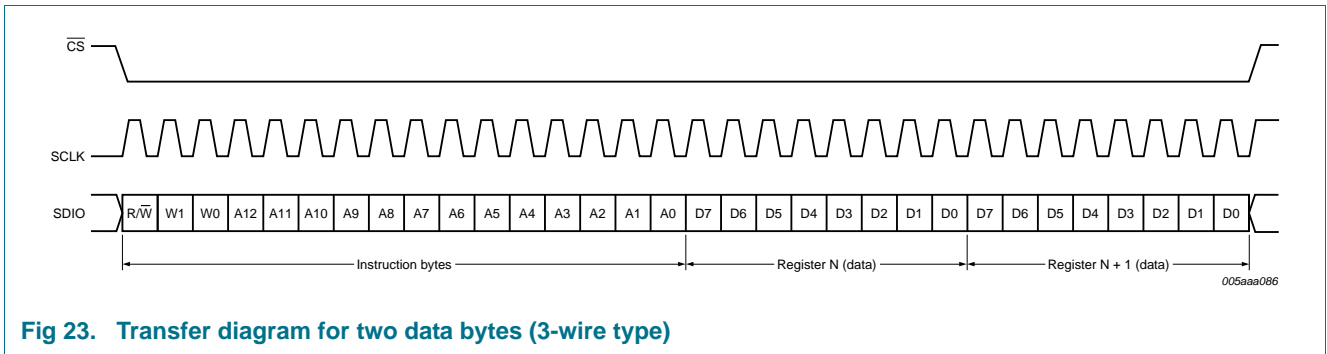

**Fig 23. Transfer diagram for two data bytes (3-wire type)**

## 11.6.2 Channel control

Table 17. Register allocation map

Address (hex)	Register name	Access <sup>[1]</sup>	Bit definition								Default <sup>[2]</sup> (bin)
			Bit 7	Bit 6	Bit 5	Bit 4	Bit 3	Bit 2	Bit 1	Bit 0	
<b>ADC control register</b>											
0003	SPI control	R/W	-	-	-	-	-	-	ENABLE	-	1111 1111
0005	Reset and Operating modes	R/W	SW_RST	-	-	-	-	-	PD[1:0]		0000 0000
0006	Clock	R/W	-	-	-	SE_SEL	DIFF_SE	-	CLKDIV2_SEL	DCS_EN	0000 000*
0008	Vref	R/W	-	-	-	-	INTREF_EN	INTREF[2:0]		0000 0000	
0013	Offset	R/W	-	-	DIG_OFFSET[5:0]					0000 0000	
0014	Test pattern 1	R/W	-	-	-	-	-	TESTPAT_1[2:0]		0000 0000	
0015	Test pattern 2	R/W	TESTPAT_2[11:4]								0000 0000
0016	Test pattern 3	R/W	TESTPAT_3[3:0]			-	-	-	-	-	0000 0000
<b>JESD204A control</b>											
0801	Ser_Status	R	RXSYNC_ERROR	RESERVED[2:0]			0	0	POR_TST	RESERVED	0010 0000
0802	Ser_Reset	R/W	SW_RST	0	0	0	FSM_SW_RST	0	0	0	0000 0000
0805	Ser_Control1	R/W	0	RESERVED	SYNC_POL	SYNC_SINGLE_ENDED	1	REV_SCR	REV_ENCODER	REV_SERIAL	0100 1001
0808	Ser_Analog_Ctrl	R/W	0	0	0	0	0	SWING_SEL[2:0]		0000 0011	
0809	Ser_ScramblerA	R/W	0	LSB_INIT[6:0]							0000 0000

Table 17. Register allocation map ...continued

Address (hex)	Register name	Access <sup>[1]</sup>	Bit definition								Default <sup>[2]</sup> (bin)
			Bit 7	Bit 6	Bit 5	Bit 4	Bit 3	Bit 2	Bit 1	Bit 0	
080A	Ser_ScramblerB	R/W	MSB_INIT[7:0]								1111 1111
080B	Ser_PRBS_Ctrl	R/W	0	0	0	0	0	0	PRBS_TYPE[1:0]		0000 0000
0820	Cfg_0_DID	R	DID[7:0]								1110 1101
0821	Cfg_1_BID	R/W*	0	0	0	0	BID[3:0]			0000 1010	
0822	Cfg_3_SCR_L	R/W*	SCR	0	0	0	0	0	0	L	0000 0000
0823	Cfg_4_F	R/W*	0	0	0	0	0	F[2:0]		0000 0***	
0824	Cfg_5_K	R/W*	0	0	0	K[4:0]					000* ****
0825	Cfg_6_M	R/W*	0	0	0	0	0	0	0	M	0000 000*
0826	Cfg_7_CS_N	R/W*	0	CS[0]	0	0	N[3:0]			0100 0010	
0827	Cfg_8_Np	R/W*	0	0	0	NP[4:0]					0000 1111
0828	Cfg_9_S	R/W*	0	0	0	0	0	0	0	S	0000 0000
0829	Cfg_10_HD_CF	R/W*	HD	0	0	0	0	0	CF[1:0]		*000 0000
082D	Cfg_02_2_LID	R/W*	0	0	0	LID[4:0]					0001 1100
084D	Cfg02_13_FCHK	R	FCHK[7:0]								**** ****
0871	Lane_0_Ctrl	R/W	0	SCR_IN_MODE	LANE_MODE[1:0]		0	LANE_POL	0	LANE_PD	0000 0000
0891	ADC_0_Ctrl	R/W	0	0	ADC_MODE[1:0]		0	0	0	ADC_PD	0000 0000

[1] An "\*" in the Access column means that this register is subject to control access conditions in Write mode.

[2] An "\*" in the Default column replaces a bit of which the value depends on the binary level of external pins (e.g. CFG[3:0], Swing[1:0], Scrambler).

11.6.3 Register description

11.6.3.1 ADC control registers

Table 18. Register SPI control (address 0003h)

Default values are highlighted.

Bit	Symbol	Access	Value	Description
7 to 2	-	-	111111	not used
1	ENABLE	R/W		ADC SPI control enable:
			0	ADC does not get the next SPI command
			1	<b>ADC gets the next SPI command</b>
0	-	-	1	not used

Table 19. Register Reset and Power-down mode (address 0005h)

Default values are highlighted.

Bit	Symbol	Access	Value	Description
7	SW_RST	R/W		reset digital part:
			0	<b>no reset</b>
			1	performs a reset of the digital part
6 to 2	-	-	00000	not used
1 to 0	PD[1-0]	R/W		Power-down mode:
			00	<b>normal (power-up)</b>
			01	full power-down
			10	sleep
			11	normal (power-up)

Table 20. Register Clock (address 0006h)

Default values are highlighted.

Bit	Symbol	Access	Value	Description
7 to 5	-	-	000	not used
4	SE_SEL	R/W		select SE clock input pin:
			0	<b>select CLKM input</b>
			1	select CLKP input
3	DIFF_SE	R/W		differential/single-ended clock input select:
			0	<b>fully differential</b>
			1	single-ended
2	-	-	0	not used
1	CLKDIV2_SEL	R/W		select clock input divider by 2:
			0	<b>disable</b>
			1	enable
0	DCS_EN	R/W		duty cycle stabilizer enable:
			0	disable
			1	enable

**Table 21. Register Vref (address 0008h)**

Default values are highlighted.

Bit	Symbol	Access	Value	Description
7 to 4	-	-	0000	not used
3	INTREF_EN	R/W		enable internal programmable VREF mode:
			<b>0</b>	<b>disable</b>
			1	enable
2 to 0	INTREF[2:0]	R/W		programmable internal reference:
			<b>000</b>	<b>0 dB (FS = 2 V)</b>
			001	-1 dB (FS = 1.78 V)
			010	-2 dB (FS = 1.59 V)
			011	-3 dB (FS = 1.42 V)
			100	-4 dB (FS = 1.26 V)
			101	-5 dB (FS = 1.12 V)
			110	-6 dB (FS = 1 V)
			111	not used

**Table 22. Digital offset adjustment (address 0013h)**

Default values are highlighted.

Register offset		
Decimal	DIG_OFFSET[5:0]	
+31	011111	+31 LSB
...	...	...
0	<b>000000</b>	0
...	...	...
-32	100000	-32 LSB

**Table 23. Register Test pattern 1 (address 0014h)**

Default values are highlighted.

Bit	Symbol	Access	Value	Description
7 to 3	-	-	00000	not used
2 to 0	TESTPAT_1[2:0]	R/W		digital test pattern:
			<b>000</b>	<b>off</b>
			001	mid-scale
			010	- FS
			011	+ FS
			100	toggle '1111..1111'/'0000..0000'
			101	custom test pattern, to be written in register 0015h and 0016h
			110	'010101...'
			111	'101010...'

**Table 24. Register Test pattern 2 (address 0015h)**

Default values are highlighted.

Bit	Symbol	Access	Value	Description
7 to 0	TESTPAT_2[11:4]	R/W	<b>00000000</b>	custom digital test pattern (bit 11 to 4)

**Table 25. Register Test pattern 3 (address 0016h)**

Default values are highlighted.

Bit	Symbol	Access	Value	Description
7 to 4	TESTPAT_3[3:0]	R/W	<b>0000</b>	custom digital test pattern (bit 3 to 0)
3 to 0	-	-	0000	not used

### 11.6.4 JESD204A digital control registers

**Table 26. SER\_Status (address 0801h)**

Default values are highlighted.

Bit	Symbol	Access	Value	Description
7	RXSYNC_ERROR	R	0	set to 1 when a synchronization error occurs
6 to 4	RESERVED[2:0]	-	<b>010</b>	reserved
3 to 2	-	-	00	not used
1	POR_TST	R	<b>0</b>	power-on-reset
0	RESERVED	-	0	reserved

**Table 27. SER\_Reset (address 0802h)**

Default values are highlighted.

Bit	Symbol	Access	Value	Description
7	SW_RST	R/W	<b>0</b>	initiates a software reset of the JESD204A unit
6 to 4	-	-	000	not used
3	FSM_SW_RST	R/W	<b>0</b>	initiates a software reset of the internal state machine of JESD204A unit
2 to 0	-	-	000	not used

**Table 28. SER\_Control1 (address 0805h)**

Default values are highlighted.

Bit	Symbol	Access	Value	Description
7	-	-	0	not used
6	RESERVED	-	0	reserved
5	SYNC_POL	R/W		defines the synchronization signal polarity:
			<b>0</b>	<b>synchronization signal is active LOW</b>
			1	synchronization signal is active HIGH
4	SYNC_SINGLE_ENDED	R/W		defines the input mode of the synchronization signal:
			<b>0</b>	<b>synchronization input mode is set in Differential mode</b>
			1	synchronization input mode is set in Single-ended mode
3	-	-	1	not used
2	REV_SCR	-		LSB are swapped to MSB at the scrambler input:
			<b>0</b>	<b>disable</b>
			1	enable

**Table 28. SER\_Control1 (address 0805h) ...continued**

Default values are highlighted.

Bit	Symbol	Access	Value	Description
1	REV_ENCODER	-		LSB are swapped to MSB at the 8-bit/10-bit encoder input:
			<b>0</b>	<b>disable</b>
			1	enable
0	REV_SERIAL	-		LSB are swapped to MSB at the lane input:
			0	disable
			<b>1</b>	<b>enable</b>

**Table 29. SER\_Analog\_Ctrl (address 0808h)**

Default values are highlighted.

Bit	Symbol	Access	Value	Description
7 to 3	-	-	00000	not used
2 to 0	SWING_SEL[2:0]	R/W	<b>011</b>	<b>defines the swing output for the lane pads</b>

**Table 30. SER\_ScramblerA (address 0809h)**

Default values are highlighted.

Bit	Symbol	Access	Value	Description
7	-	-	0	not used
6 to 0	LSB_INIT[6:0]	R/W	<b>0000000</b>	<b>defines the initialization vector for the scrambler polynomial (lower)</b>

**Table 31. SER\_ScramblerB (address 080Ah)**

Default values are highlighted.

Bit	Symbol	Access	Value	Description
7 to 0	MSB_INIT[7:0]	R/W	<b>11111111</b>	<b>defines the initialization vector for the scrambler polynomial (upper)</b>

**Table 32. SER\_PRBS\_Ctrl (address 080Bh)**

Default values are highlighted.

Bit	Symbol	Access	Value	Description
7 to 2	-	-	000000	not used
1 to 0	PRBS_TYPE[1:0]	R/W		defines the type of Pseudo-Random Binary Sequence (PRBS) generator to be used:
			<b>00</b> (reset)	<b>PRBS-7</b>
			01	PRBS-7
			10	PRBS-23
			11	PRBS-31

**Table 33. Cfg\_0\_DID (address 0820h)**

Default values are highlighted.

Bit	Symbol	Access	Value	Description
7 to 0	DID[7:0]	R	<b>11101101</b>	<b>defines the device (= link) identification number</b>

**Table 34. Cfg\_1\_BID (address 0821h)***Default values are highlighted.*

Bit	Symbol	Access	Value	Description
7 to 4	-	-	0000	not used
3 to 0	BID[3:0]	R/W	<b>1010</b>	<b>defines the bank ID – extension to DID</b>

**Table 35. Cfg\_3\_SCR\_L (address 0822h)***Default values are highlighted.*

Bit	Symbol	Access	Value	Description
7	SCR	R/W	0	scrambling enabled
6 to 1	-	-	000000	not used
0	L	R/W	0	defines the number of lanes per converter device, minus 1

**Table 36. Cfg\_4\_F (address 0823h)***Default values are highlighted.*

Bit	Symbol	Access	Value	Description
7 to 3	-	-	00000	not used
2 to 0	F[2:0]	R/W	<b>***</b>	defines the number of octets per frame, minus 1

**Table 37. Cfg\_5\_K (address 0824h)***Default values are highlighted.*

Bit	Symbol	Access	Value	Description
7 to 5	-	-	000	not used
4 to 0	K[4:0]	R/W	<b>*****</b>	defines the number of frames per multiframe, minus 1

**Table 38. Cfg\_6\_M (address 0825h)***Default values are highlighted.*

Bit	Symbol	Access	Value	Description
7 to 1	-	-	0000000	not used
0	M	R/W	<b>*</b>	defines the number of converters per device, minus 1

**Table 39. Cfg\_7\_CS\_N (address 0826h)***Default values are highlighted.*

Bit	Symbol	Access	Value	Description
7	-	-	0	not used
6	CS[0]	R/W	1	defines the number of control bits per sample, minus 1
5 to 4	-	-	00	not used
3 to 0	N[3:0]	R/W	0010	defines the converter resolution

**Table 40. Cfg\_8\_Np (address 0827h)***Default values are highlighted.*

Bit	Symbol	Access	Value	Description
7 to 5	-	-	000	not used
4 to 0	NP[4:0]	R/W	01111	defines the total number of bits per sample, minus 1

**Table 41. Cfg\_9\_S (address 0828h)**

Default values are highlighted.

Bit	Symbol	Access	Value	Description
7 to 1	-	-	0000000	not used
0	S	R/W	<b>0</b>	<b>defines number of samples per converter per frame cycle</b>

**Table 42. Cfg\_10\_HD\_CF (address 0829h)**

Default values are highlighted.

Bit	Symbol	Access	Value	Description
7	HD	R/W	*	defines high density format
6 to 2	-	-	00000	not used
1 to 0	CF[1:0]	R/W	00	defines number of control words per frame clock cycle per link.

**Table 43. Cfg\_02\_2\_LID (address 082Dh)**

Default values are highlighted.

Bit	Symbol	Access	Value	Description
7 to 5	-	-	000	not used
4 to 0	LID[4:0]	R/W	<b>11100</b>	<b>defines lane identification number</b>

**Table 44. Cfg02\_13\_FCHK (address 084Dh)**

Default values are highlighted.

Bit	Symbol	Access	Value	Description
7 to 0	FCHK[7:0]	R	*****	defines the checksum value for lane checksum corresponds to the sum of all the link configuration parameters module 256 (as defined in JEDEC Standard No.204A)

**Table 45. Lane\_0\_Ctrl (address 0871h)**

Default values are highlighted.

Bit	Symbol	Access	Value	Description
7	-	-	0	not used
6	SCR_IN_MODE	R/W		defines the input type for scrambler and 8-bit/10-bit units:
			<b>0</b> (reset)	<b>(normal mode) = input of the scrambler and 8-bit/10-bit units is the output of the frame assembly unit.</b>
			1	input of the scrambler and 8-bit/10-bit units is the PRBS generator (PRBS type is defined with "PRBS_TYPE[1:0]" (Ser_PRBS_Ctrl register)
5 to 4	LANE_MODE[1:0]	R/W		defines output type of lane output unit:
			<b>00</b> (reset)	<b>normal mode: lane output is the 8-bit/10-bit output unit</b>
			01	constant mode: lane output is set to a constant (0 × 0)
			10	toggle mode: lane output is toggling between 0 × 0 and 0 × 1
			11	PRBS mode: lane output is the PRBS generator (PRBS type is defined with "PRBS_TYPE[1:0]" (Ser_PRBS_Ctrl register)
3	-	-	0	not used

**Table 45. Lane\_0\_Ctrl (address 0871h) ...continued***Default values are highlighted.*

Bit	Symbol	Access	Value	Description
2	LANE_POL	R/W		defines lane polarity:
			<b>0</b>	<b>lane polarity is normal</b>
			1	lane polarity is inverted
1	RESERVED	R/W	0	reserved
0	LANE_PD	R/W		lane power-down control:
			<b>0</b>	<b>lane is operational</b>
			1	lane is in Power-down mode

**Table 46. ADC\_0\_Ctrl (address 0891h)***Default values are highlighted.*

Bit	Symbol	Access	Value	Description
7 to 6	-	-	00	not used
5 to 4	ADC_MODE[1:0]	R/W		defines input type of JESD204A unit
			<b>00</b> (reset)	<b>ADC output is connected to the JESD204A input</b>
			01	not used
			10	JESD204A input is fed with a dummy constant, set to: OTR = 0 and ADC[13:0] = "10011011101010"
			11	JESD204A is fed with a PRBS generator (PRBS type is defined with "PRBS_TYPE[1:0]" (Ser_PRBS_Ctrl register)
3 to 1	-	-	000	not used
0	ADC_PD	R/W		ADC power-down control:
			<b>0</b>	<b>ADC is operational</b>
			1	ADC is in Power-down mode

12. Package outline

HVQFN32R: plastic thermal enhanced very thin quad flat package; no leads; 32 terminals; resin based; body 7 x 7 x 0.8 mm

SOT1152-1

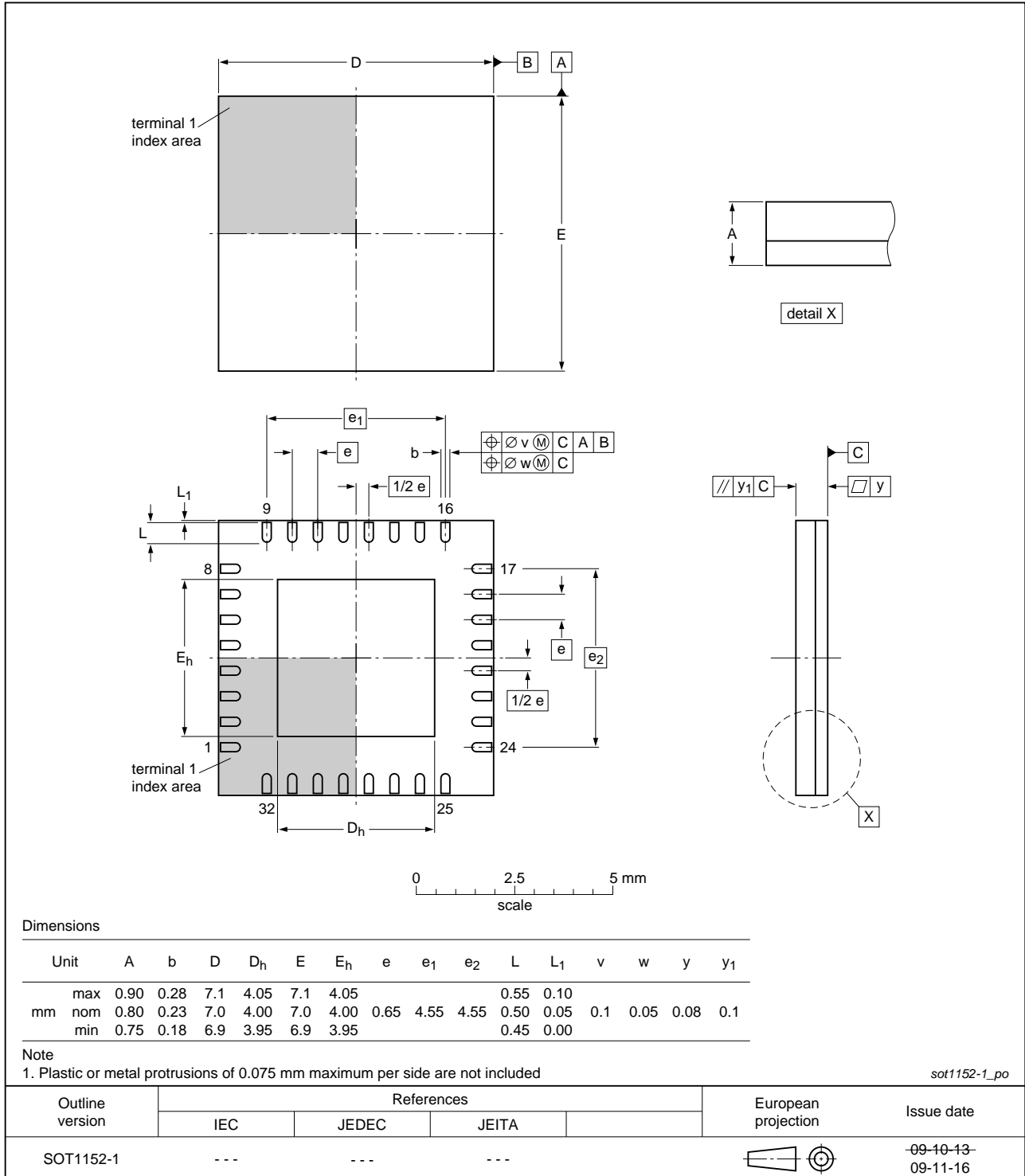

Fig 24. Package outline SOT1152-1 (HVQFN32)

## 13. Abbreviations

Table 47. Abbreviations

Acronym	Description
ADC	Analog-to-Digital Converter
DCS	Duty Cycle Stabilizer
ESD	ElectroStatic Discharge
IF	Intermediate Frequency
IMD	InterModulation Distortion
LSB	Least Significant Bit
LVCMOS	Low-Voltage Complementary Metal-Oxide Semiconductor
LVPECL	Low-Voltage Positive Emitter-Coupled Logic
MSB	Most Significant Bit
OTR	Out-of-Range
PRBS	Pseudo-Random Binary Sequence
SFDR	Spurious-Free Dynamic Range
SNR	Signal-to-Noise Ratio
SPI	Serial Peripheral Interface
TX	Transmitter

## 14. Revision history

Table 48. Revision history

Document ID	Release date	Data sheet status	Change notice	Supersedes
ADC1213S_SER v.2	20110609	Product data sheet	-	ADC1213S_SER v.1
Modifications:	• <a href="#">Section 10.2 "Clock and digital output timing"</a> has been updated.			
ADC1213S_SER v.1	20110314	Product data sheet	-	-

## 15. Legal information

### 15.1 Data sheet status

Document status <sup>[1][2]</sup>	Product status <sup>[3]</sup>	Definition
Objective [short] data sheet	Development	This document contains data from the objective specification for product development.
Preliminary [short] data sheet	Qualification	This document contains data from the preliminary specification.
Product [short] data sheet	Production	This document contains the product specification.

[1] Please consult the most recently issued document before initiating or completing a design.

[2] The term 'short data sheet' is explained in section "Definitions".

[3] The product status of device(s) described in this document may have changed since this document was published and may differ in case of multiple devices. The latest product status information is available on the Internet at URL <http://www.nxp.com>.

### 15.2 Definitions

**Draft** — The document is a draft version only. The content is still under internal review and subject to formal approval, which may result in modifications or additions. NXP Semiconductors does not give any representations or warranties as to the accuracy or completeness of information included herein and shall have no liability for the consequences of use of such information.

**Short data sheet** — A short data sheet is an extract from a full data sheet with the same product type number(s) and title. A short data sheet is intended for quick reference only and should not be relied upon to contain detailed and full information. For detailed and full information see the relevant full data sheet, which is available on request via the local NXP Semiconductors sales office. In case of any inconsistency or conflict with the short data sheet, the full data sheet shall prevail.

**Product specification** — The information and data provided in a Product data sheet shall define the specification of the product as agreed between NXP Semiconductors and its customer, unless NXP Semiconductors and customer have explicitly agreed otherwise in writing. In no event however, shall an agreement be valid in which the NXP Semiconductors product is deemed to offer functions and qualities beyond those described in the Product data sheet.

### 15.3 Disclaimers

**Limited warranty and liability** — Information in this document is believed to be accurate and reliable. However, NXP Semiconductors does not give any representations or warranties, expressed or implied, as to the accuracy or completeness of such information and shall have no liability for the consequences of use of such information.

In no event shall NXP Semiconductors be liable for any indirect, incidental, punitive, special or consequential damages (including - without limitation - lost profits, lost savings, business interruption, costs related to the removal or replacement of any products or rework charges) whether or not such damages are based on tort (including negligence), warranty, breach of contract or any other legal theory.

Notwithstanding any damages that customer might incur for any reason whatsoever, NXP Semiconductors' aggregate and cumulative liability towards customer for the products described herein shall be limited in accordance with the *Terms and conditions of commercial sale* of NXP Semiconductors.

**Right to make changes** — NXP Semiconductors reserves the right to make changes to information published in this document, including without limitation specifications and product descriptions, at any time and without notice. This document supersedes and replaces all information supplied prior to the publication hereof.

**Suitability for use** — NXP Semiconductors products are not designed, authorized or warranted to be suitable for use in life support, life-critical or safety-critical systems or equipment, nor in applications where failure or

malfunction of an NXP Semiconductors product can reasonably be expected to result in personal injury, death or severe property or environmental damage. NXP Semiconductors accepts no liability for inclusion and/or use of NXP Semiconductors products in such equipment or applications and therefore such inclusion and/or use is at the customer's own risk.

**Applications** — Applications that are described herein for any of these products are for illustrative purposes only. NXP Semiconductors makes no representation or warranty that such applications will be suitable for the specified use without further testing or modification.

Customers are responsible for the design and operation of their applications and products using NXP Semiconductors products, and NXP Semiconductors accepts no liability for any assistance with applications or customer product design. It is customer's sole responsibility to determine whether the NXP Semiconductors product is suitable and fit for the customer's applications and products planned, as well as for the planned application and use of customer's third party customer(s). Customers should provide appropriate design and operating safeguards to minimize the risks associated with their applications and products.

NXP Semiconductors does not accept any liability related to any default, damage, costs or problem which is based on any weakness or default in the customer's applications or products, or the application or use by customer's third party customer(s). Customer is responsible for doing all necessary testing for the customer's applications and products using NXP Semiconductors products in order to avoid a default of the applications and the products or of the application or use by customer's third party customer(s). NXP does not accept any liability in this respect.

**Limiting values** — Stress above one or more limiting values (as defined in the Absolute Maximum Ratings System of IEC 60134) will cause permanent damage to the device. Limiting values are stress ratings only and (proper) operation of the device at these or any other conditions above those given in the Recommended operating conditions section (if present) or the Characteristics sections of this document is not warranted. Constant or repeated exposure to limiting values will permanently and irreversibly affect the quality and reliability of the device.

**Terms and conditions of commercial sale** — NXP Semiconductors products are sold subject to the general terms and conditions of commercial sale, as published at <http://www.nxp.com/profile/terms>, unless otherwise agreed in a valid written individual agreement. In case an individual agreement is concluded only the terms and conditions of the respective agreement shall apply. NXP Semiconductors hereby expressly objects to applying the customer's general terms and conditions with regard to the purchase of NXP Semiconductors products by customer.

**No offer to sell or license** — Nothing in this document may be interpreted or construed as an offer to sell products that is open for acceptance or the grant, conveyance or implication of any license under any copyrights, patents or other industrial or intellectual property rights.

**Export control** — This document as well as the item(s) described herein may be subject to export control regulations. Export might require a prior authorization from national authorities.

**Non-automotive qualified products** — Unless this data sheet expressly states that this specific NXP Semiconductors product is automotive qualified, the product is not suitable for automotive use. It is neither qualified nor tested in accordance with automotive testing or application requirements. NXP Semiconductors accepts no liability for inclusion and/or use of non-automotive qualified products in automotive equipment or applications.

In the event that customer uses the product for design-in and use in automotive applications to automotive specifications and standards, customer (a) shall use the product without NXP Semiconductors' warranty of the product for such automotive applications, use and specifications, and (b) whenever customer uses the product for automotive applications beyond

NXP Semiconductors' specifications such use shall be solely at customer's own risk, and (c) customer fully indemnifies NXP Semiconductors for any liability, damages or failed product claims resulting from customer design and use of the product for automotive applications beyond NXP Semiconductors' standard warranty and NXP Semiconductors' product specifications.

## 15.4 Trademarks

Notice: All referenced brands, product names, service names and trademarks are the property of their respective owners.

## 16. Contact information

For more information, please visit: <http://www.nxp.com>

For sales office addresses, please send an email to: [salesaddresses@nxp.com](mailto:salesaddresses@nxp.com)

## 17. Contents

<b>1</b>	<b>General description</b> . . . . .	<b>1</b>	<b>15</b>	<b>Legal information</b> . . . . .	<b>37</b>
<b>2</b>	<b>Features and benefits</b> . . . . .	<b>1</b>	15.1	Data sheet status . . . . .	37
<b>3</b>	<b>Applications</b> . . . . .	<b>1</b>	15.2	Definitions . . . . .	37
<b>4</b>	<b>Ordering information</b> . . . . .	<b>2</b>	15.3	Disclaimers . . . . .	37
<b>5</b>	<b>Block diagram</b> . . . . .	<b>3</b>	15.4	Trademarks . . . . .	38
<b>6</b>	<b>Pinning information</b> . . . . .	<b>4</b>	<b>16</b>	<b>Contact information</b> . . . . .	<b>38</b>
6.1	Pinning . . . . .	4	<b>17</b>	<b>Contents</b> . . . . .	<b>39</b>
6.2	Pin description . . . . .	4			
<b>7</b>	<b>Limiting values</b> . . . . .	<b>5</b>			
<b>8</b>	<b>Thermal characteristics</b> . . . . .	<b>5</b>			
<b>9</b>	<b>Static characteristics</b> . . . . .	<b>6</b>			
<b>10</b>	<b>Dynamic characteristics</b> . . . . .	<b>9</b>			
10.1	Dynamic characteristics . . . . .	9			
10.2	Clock and digital output timing . . . . .	10			
10.3	Serial output timing . . . . .	11			
10.4	SPI timing . . . . .	12			
<b>11</b>	<b>Application information</b> . . . . .	<b>13</b>			
11.1	Analog inputs . . . . .	13			
11.1.1	Input stage description . . . . .	13			
11.1.2	Anti-kickback circuitry . . . . .	13			
11.1.3	Transformer . . . . .	14			
11.2	System reference and power management . . . . .	15			
11.2.1	Internal/external reference . . . . .	15			
11.2.2	Programmable full-scale . . . . .	17			
11.2.3	Common-mode output voltage ( $V_{O(cm)}$ ) . . . . .	17			
11.2.4	Biasing . . . . .	18			
11.3	Clock input . . . . .	18			
11.3.1	Drive modes . . . . .	18			
11.3.2	Equivalent input circuit . . . . .	19			
11.3.3	Duty cycle stabilizer . . . . .	20			
11.3.4	Clock input divider . . . . .	20			
11.4	Digital outputs . . . . .	20			
11.4.1	Serial output equivalent circuit . . . . .	20			
11.5	JESD204A serializer . . . . .	21			
11.5.1	Digital JESD204A formatter . . . . .	21			
11.5.2	ADC core output codes versus input voltage . . . . .	22			
11.6	Serial Peripheral Interface (SPI) . . . . .	23			
11.6.1	Register description . . . . .	23			
11.6.2	Channel control . . . . .	25			
11.6.3	Register description . . . . .	27			
11.6.3.1	ADC control registers . . . . .	27			
11.6.4	JESD204A digital control registers . . . . .	29			
<b>12</b>	<b>Package outline</b> . . . . .	<b>34</b>			
<b>13</b>	<b>Abbreviations</b> . . . . .	<b>35</b>			
<b>14</b>	<b>Revision history</b> . . . . .	<b>36</b>			

Please be aware that important notices concerning this document and the product(s) described herein, have been included in section 'Legal information'.

© NXP B.V. 2011.

All rights reserved.

For more information, please visit: <http://www.nxp.com>

For sales office addresses, please send an email to: [salesaddresses@nxp.com](mailto:salesaddresses@nxp.com)

Date of release: 9 June 2011

Document identifier: ADC1213S\_SER