

V1KU Starter Kit

Introduction

The V1KU Starter Kit allows developers and OEMs to evaluate the use of the CM1K pattern recognition chip for image and pattern recognition applications. The board features an Aptina monochrome CMOS sensor, a CM1K chip with 1024 neurons, a recognition engine programmed on the FPGA, 8 MB of SDRAM and 4 MB of Flash memory. The communication bus includes high-speed USB and RS485 buses.

Recognition Logic

The recognition engine programmed in the FPGA is capable of learning examples, recognizing objects at a fixed location and searching for objects over a larger area. Simple monitoring of a fixed region runs at 60 frames per second. Looking for objects in an entire video frame ranges between 500µsec to 2 seconds depending on the size of the region and scanning step. The engine uses the neurons of the CogniMem chip to build the knowledge base and recognize at such high-speed.

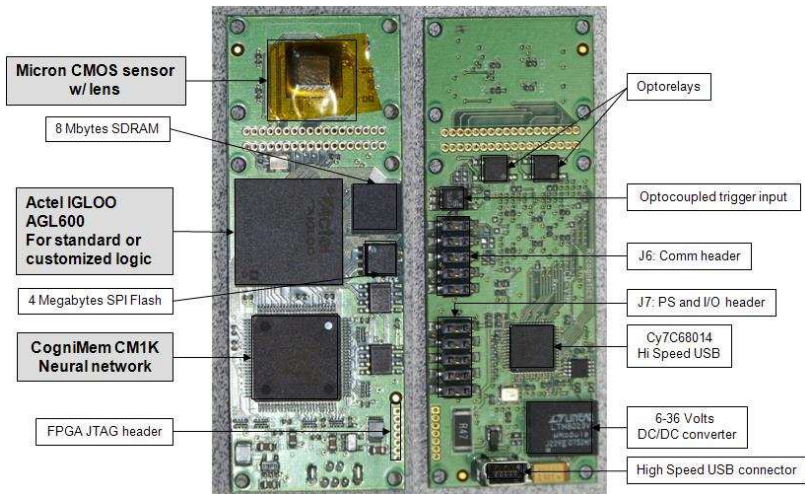

Access to all the components of the board is made via a simple Register Transfer Level (RTL) protocol. The CogniMem chip can be used independently from the recognition engine, to learn and recognize vector data transmitted from a host. FPGA programmers can implement their own feature extraction, results conditioning, and transmission to run on the board as an embedded platform.

Industrial Automation

- Conformity Verification
- Alignment Verification
- Anomaly Detection
- Predictive Maintenance

Video Surveillance

- Event Recognition
- Novelty Detection
- Facial Recognition

Robotics

- Object Detection
- Target Tracking
- Autonomous Motion Control



Target Tracking

Object Recognition

Surface Classification

Anomaly Detection

Template Matching

Novelty Detection

V1KU Starter Kit

Component Specifications

Aptina/Micron MT9V022 Video Sensor

- Monochrome, progressive scan
- 752x480 pixels, 60 frames per second
- Global shutter for fast moving objects
- 6mm M7 lens w/ holder

I/O Buses

- Miniature USB Hi Speed (480 Mbps)
- I2C serial interface (100 - 400 Kbit)
- 2 RS485 serial output
- 1 opto isolated input line
- 2 opto isolated output lines (<60 v, 500 mA)
- Two 10-pin headers

Mechanical and Electrical

- Powered through USB or external supply
- 6v to 36v, 1 Watt
- 27 x 70 mm, 120 grams

CM1K Neural Network Chip

- 1024 silicon neurons working in parallel
- Classify vectors of up to 256 bytes
- Up to 16382 categories
- Up to 127 sub-networks per chip
- Category readout in 36 clock cycles per firing neuron (1.4µsec @ 24 MHz clock)
- Radial Basis Function or K-NN classifier
- Real time self-adaptive model generator

Embedded Recognition Engine on FPGA

- Simple Read/Write protocol to access all components via USB or RS485
- Learning and recognition of a fixed region
- Finding of objects in a region of search
- Grab video to memory
- Load images from and transfer to host
- Output to opto-isolated relays

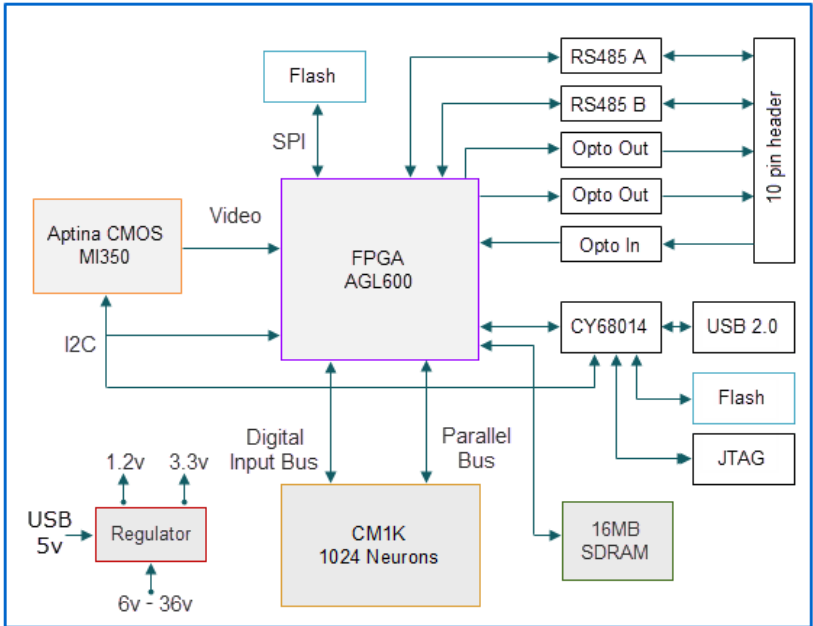

J6 pins	Description
1	RS485 data+ Channel B
2	I2C Clock
3	RS485 data+ Channel A
4	I2C_Data
5	GND power
6	Opto In anode
7	RS485 data- Channel B
8	RS485 data- Channel A
9	6-36 VDC power
10	Opto in cathode
J7 pins	Description
1	6-36 VDC power
2	6-36 VDC power
3	Relay output 0 cathode
4	Relay output 0 anode
5	Relay output 1 anode
6	Relay output 1 cathode
7	Opto In anode
8	Opto in cathode
9	GND power
10	GND power

V1KU Starter Kit

Deliverables



The V1KU Starter Kit includes one V1KU board with stand and a link to Image Trainer software ready to interface with the board through its USB port, as well as a Software Development Kit (SDK) for C/C++ or .Net development platforms.

The Image trainer lets you collect and display live video images, select and teach examples of objects and review and monitor the recognition of new images. The knowledge created under the Image trainer is fully compatible with the functions of the SDK and can be ported to multiple V1KU devices.

The SDK is composed of a DLL accessing all the registers of the CM1K chip, the Aptina sensor and the recognition engine. It is delivered with example source code. Programmers have a choice between the SDK for standard C or .NET.