

Features

- High current operation for greater luminous output
- Rivet design allows for solderless mounting
- Low power consumption and thermal resistance
- Can be used with automatic insertion equipment
- RoHS compliant.



Benefits:

- Rugged design allows for easy maintenance
- Robust package for optimum reliability

Typical Applications:

- Automotive side markers
- Gaming and entertainment lighting
- Signs and road hazard indicators

Package Schematics

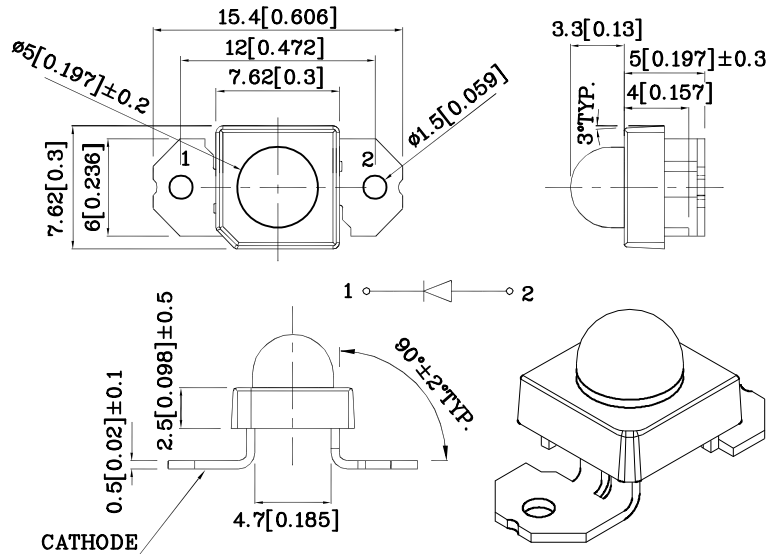

Notes:

1. All dimensions are in millimeters (inches).
2. Tolerance is $\pm 0.25 (0.01)$ unless otherwise noted.
3. Specifications are subject to change without notice.

Absolute Maximum Ratings (T _A =25°C)		M2ACR (AlGaInP)	Unit
Reverse Voltage	V _R	5	V
DC Forward Current	I _F	70	mA
Power Dissipation	P _D	210	mW
Operating Temperature	T _A	-40 ~ +85	°C
Storage Temperature	T _{stg}	-55 ~ +85	
Lead Solder Temperature [1.5mm(0.06inch)Below Seating Plane.[1]	260°C For 5 Seconds		

Operating Characteristics (T _A =25°C)		M2ACR (AlGaInP)	Unit
Forward Voltage (Min.) (I _F =70mA)	V _F	2.2	V
Forward Voltage (Typ.) (I _F =70mA)	V _F	2.4	V
Forward Voltage (Max.) (I _F =70mA)	V _F	3.0	V
Reverse Current (Max.) (V _R =5V)	I _R	10	uA
Wavelength of Peak Emission (Typ.) (I _F =70mA)	λ _P	640	nm
Wavelength of Dominant Emission (Typ.) (I _F =70mA)	λ _D	625	nm
Spectral Line Full Width At Half Maximum (Typ.) (I _F =70mA)	Δλ	25	nm
Capacitance (Typ.) (V _F =0V, f=1MHz)	C	27	pF
Thermal Resistance (Typ.)	Rθj-pin	125	°C/W

Part Number	Emitting Color	Emitting Material	Lens-color	Luminous Intensity (I _F =70mA)		Luminous Flux (I _F =70mA) lm	Viewing Angle 2θ 1/2
				min.	typ.		
XSM2ACR93W	Red	AlGaInP	Water Clear	9	17.99	5.3	30°

1. Luminous intensity is measured with an integrating sphere after the device has stabilized.

2. θ 1/2 is the angle from optical centerline where the luminous intensity is 1/2 of the optical peak value.

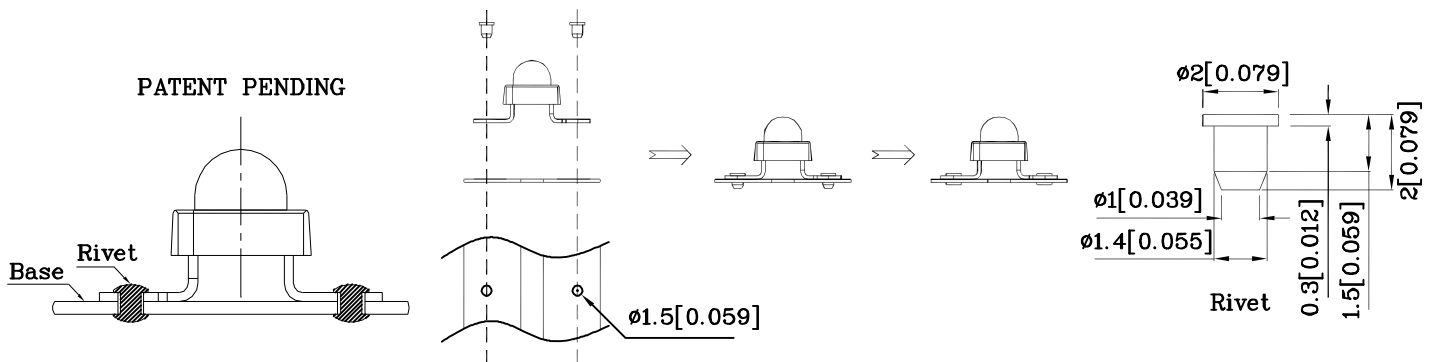
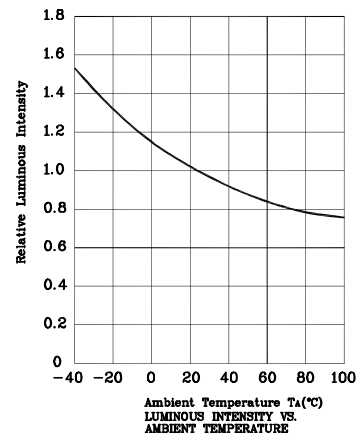
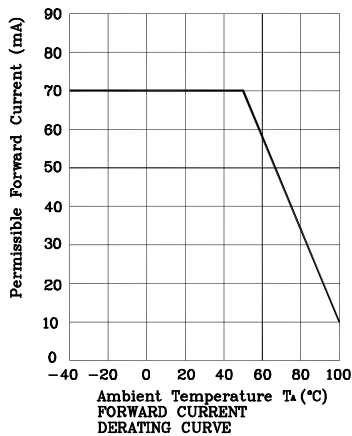
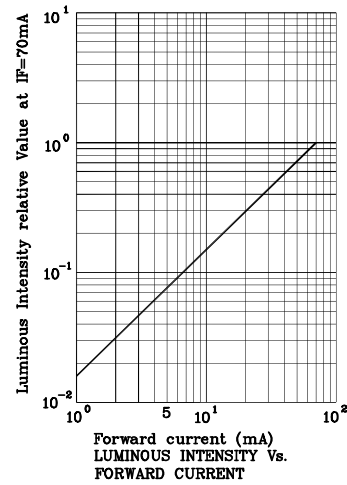
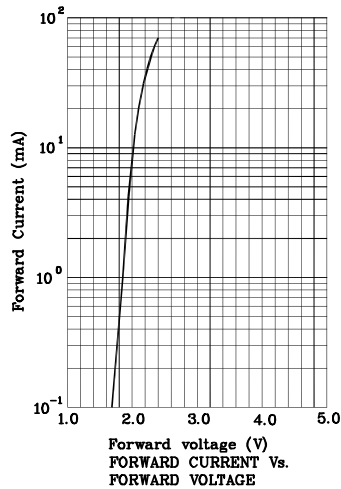
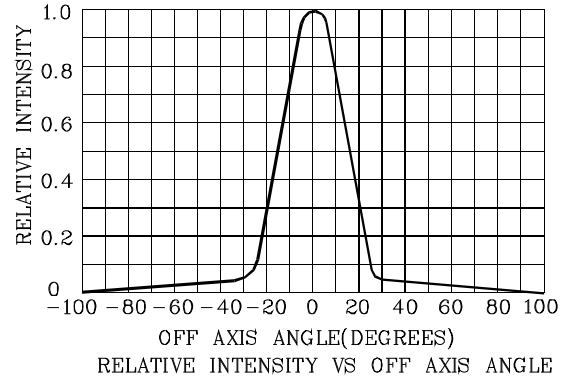
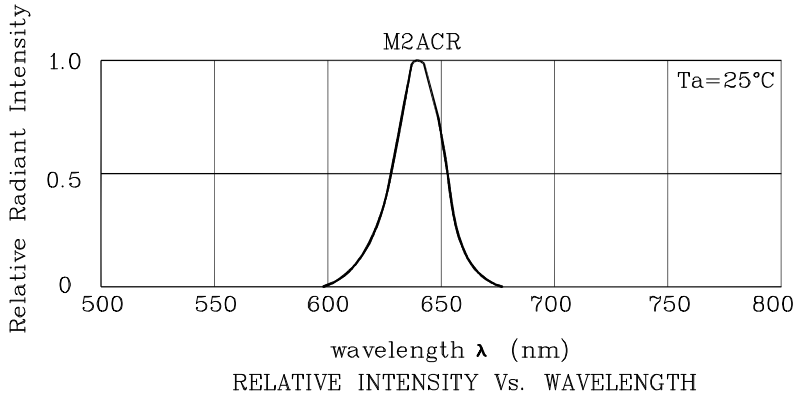

Wave Soldering Profile for Thru-Hole Products (Pb-Free Components)

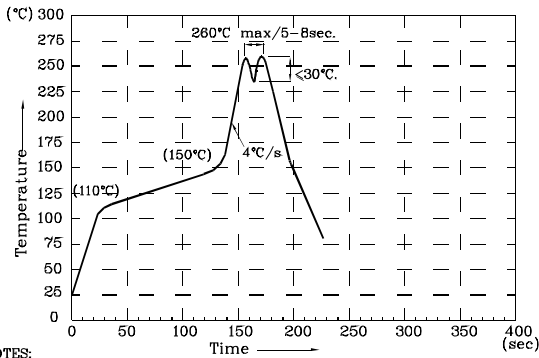

NOTES:

1. Recommend the wave temperature 245°C~260°C. The maximum soldering temperature should be less than 260°C.
2. Do not apply stress on epoxy resins when temperature is over 85°C.
3. The soldering profile apply to the lead free soldering (Sn/Cu/Ag alloy).
4. During wave soldering, the PCB top-surface temperature should be kept below 105°C.
5. No more than once.



Remarks:

If special sorting is required (e.g. binning based on forward voltage, luminous intensity / luminous flux, or wavelength), the typical accuracy of the sorting process is as follows:

1. Wavelength: +/-1nm
2. Luminous Intensity / Luminous Flux: +/-15%
3. Forward Voltage: +/-0.1V

Note: Accuracy may depend on the sorting parameters.

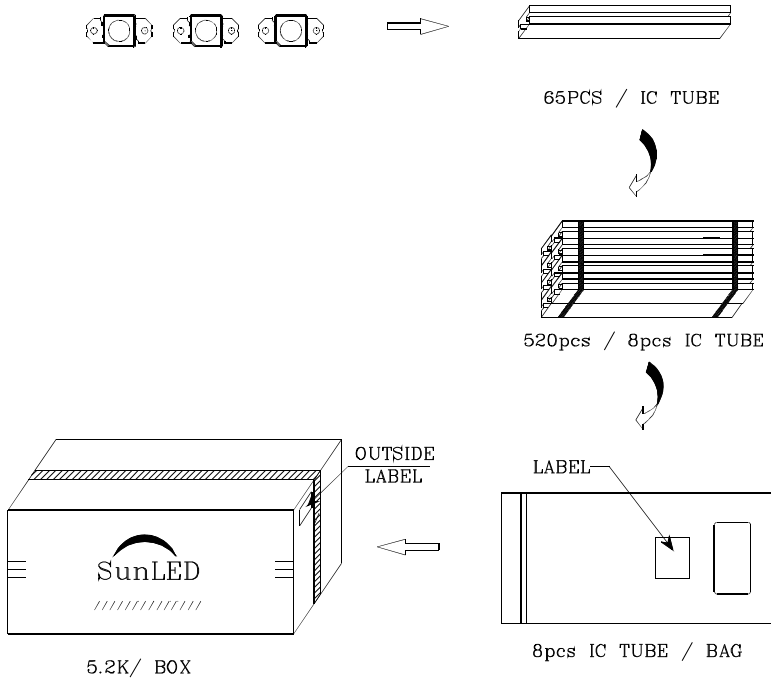
PACKING & LABEL SPECIFICATIONS

Q.C. Q.C.
XX XX XXXX
PASSED

P/NO : XSxxx93x

QTY : 520 pcs CODE: XXX

S/N : XX

LOT NO:



RoHS Compliant