

**Features**

- Housing material: Type 66 Nylon
- Housing UL rating: 94V-0
- Reliable & robust
- 5V internal resistor
- RoHS Compliant

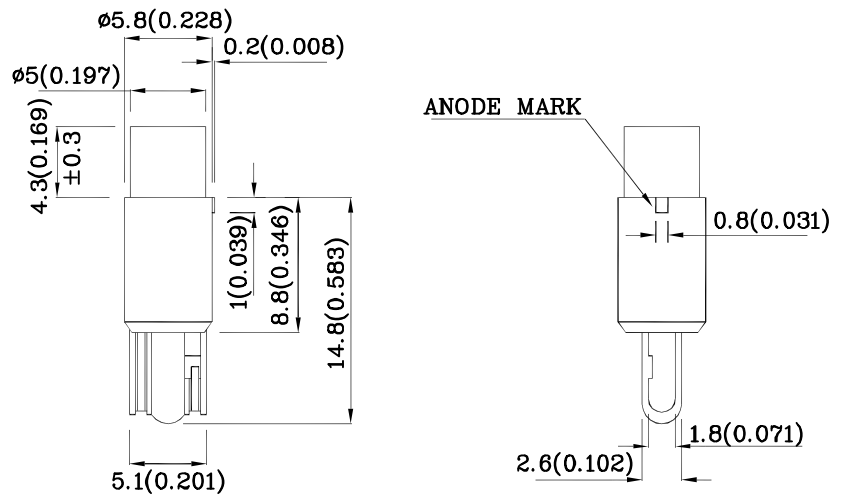

**Package Schematics**



Notes:

1. All dimensions are in millimeters (inches).
2. Tolerance is  $\pm 0.25(0.01)$  unless otherwise noted.
3. Specifications are subject to change without notice.

Absolute Maximum Ratings ( $T_A=25^\circ\text{C}$ )		MDK (AlGaInP)	Unit
Reverse Voltage	$V_R$	5	V
Forward Voltage	$V_F$	6	V
Power Dissipation	$P_D$	85	mW
Operating Temperature	$T_A$	-40 ~ +70	°C
Storage Temperature	$T_{stg}$	-40 ~ +85	
Lead Solder Temperature [2mm Below Package Base]	260°C For 3 Seconds		
Lead Solder Temperature [5mm Below Package Base]	260°C For 5 Seconds		

Operating Characteristics ( $T_A=25^\circ\text{C}$ )		MDK (AlGaInP)	Unit
Forward Current (Typ.) ( $V_F=5\text{V}$ )	$I_F$	13	mA
Forward Current (Max.) ( $V_F=5\text{V}$ )	$I_F$	17.5	mA
Reverse Current (Max.) ( $V_R=5\text{V}$ )	$I_R$	10	uA
Wavelength of Peak Emission CIE127-2007*(Typ.) ( $V_F=5\text{V}$ )	$\lambda_P$	650 645*	nm
Wavelength of Dominant Emission CIE127-2007*(Typ.) ( $V_F=5\text{V}$ )	$\lambda_D$	630 630*	nm
Spectral Line Full Width At Half-Maximum (Typ.) ( $V_F=5\text{V}$ )	$\Delta\lambda$	28	nm

Part Number	Emitting Color	Emitting Material	Lens-color	Luminous Intensity CIE127-2007* ( $V_F=5\text{V}$ ) mcd		Wavelength CIE127-2007* $\lambda_P$ nm	Viewing Angle 2 $\theta$ 1/2
				min.	typ.		
XNZSMDK52W5V02	Red	AlGaInP	Water Clear	80 30*	148 50*	650 645*	70°

\*Luminous intensity value and wavelength are in accordance with CIE127-2007 standards.

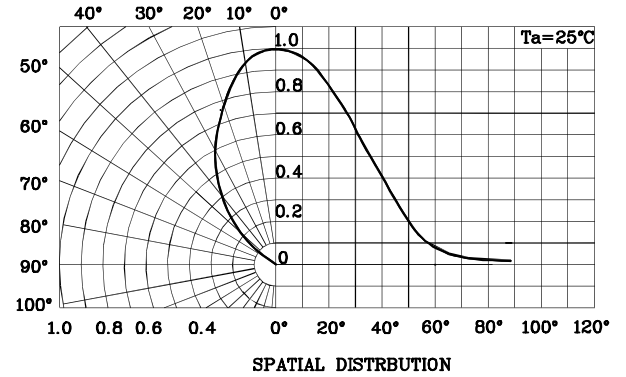
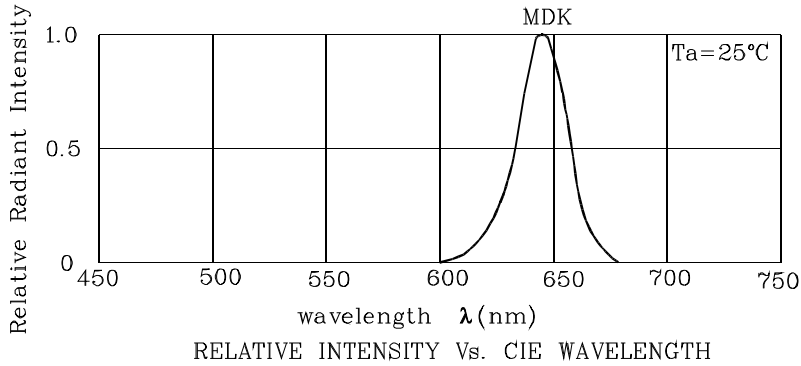

❖ MDK

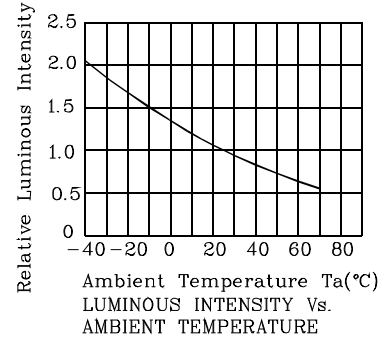
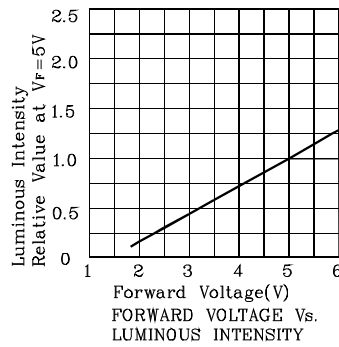
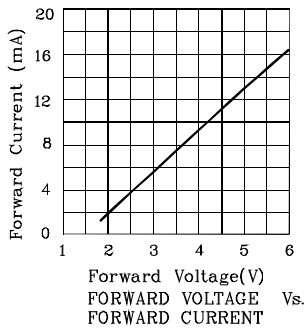

Wave Soldering Profile For Thru-Hole Products (Pb-Free Components)

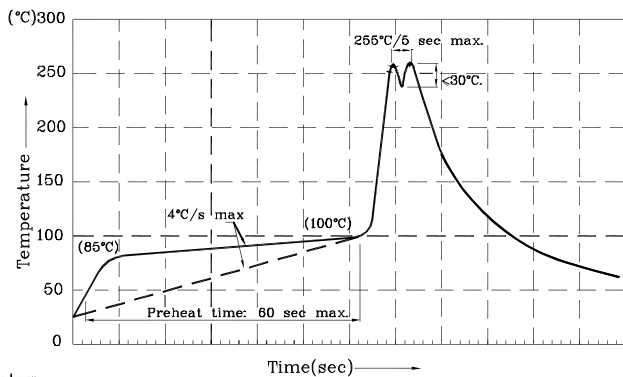

Notes:

1. Recommend pre-heat temperature of 105°C or less (as measured with a thermocouple attached to the LED pins) prior to immersion in the solder wave with a maximum solder bath temperature of 260°C
2. Peak wave soldering temperature between 245°C ~ 255°C for 3 sec (5 sec max).
3. Do not apply stress to the epoxy resin while the temperature is above 85°C.
4. Fixtures should not incur stress on the component when mounting and during soldering process.
5. SAC 305 solder alloy is recommended.
6. No more than one wave soldering pass.



Remarks:

If special sorting is required (e.g. binning based on Luminous intensity/ luminous flux, or wavelength), the typical accuracy of the sorting process is as follows:

1. Wavelength: +/-1nm
2. Luminous intensity/ luminous flux: +/-15%

Note: Accuracy may depend on the sorting parameters.

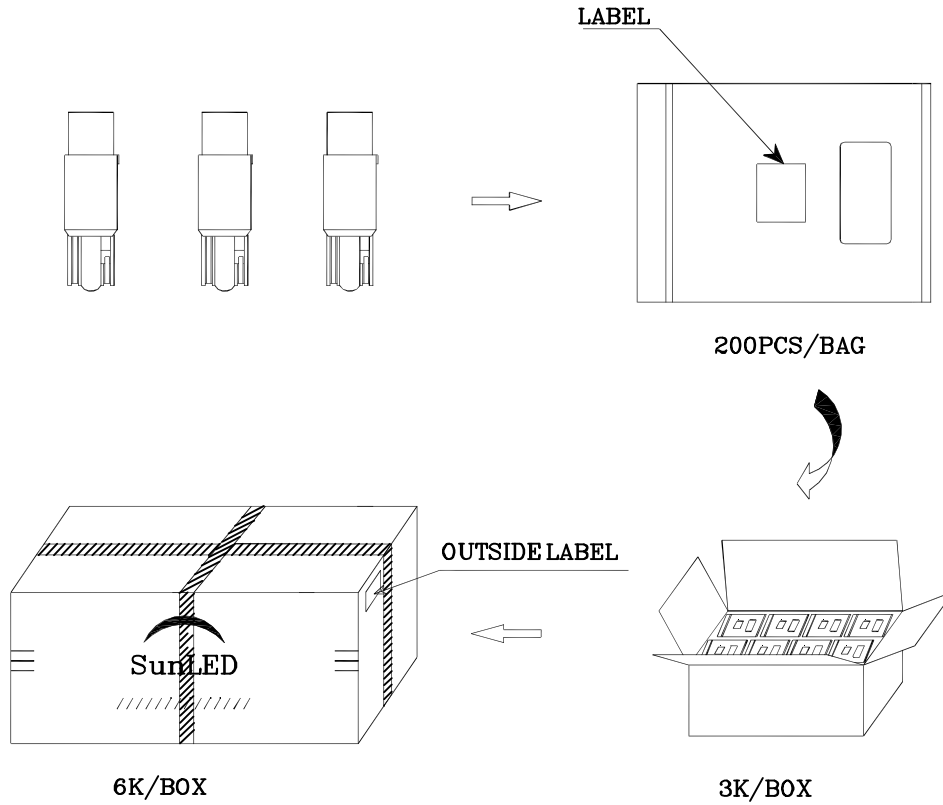
**PACKING & LABEL SPECIFICATIONS**

Q.C  
 Q C  
 XX XX XXXX  
 PASSED

P/N0 : XNZSxxx52xx02	
QTY : 200 pcs	CODE: XXX
S/N : XX	
LOT NO:	
 XXXXXXXXXXXXXXXXXXXXXXXXXXXX	
RoHS Compliant	