

Features

- High current operation for greater luminous output
- Low power consumption and thermal resistance
- Can be used with automatic insertion equipment
- RoHS Compliant



Benefits:

- Rugged design allows for easy maintenance
- Robust package for optimum reliability

Typical Applications:

- Automotive side markers
- Gaming and entertainment lighting
- Signs and road hazard indicators



ATTENTION
OBSERVE PRECAUTIONS
FOR HANDLING
ELECTROSTATIC
DISCHARGE
SENSITIVE
DEVICES

Package Schematics

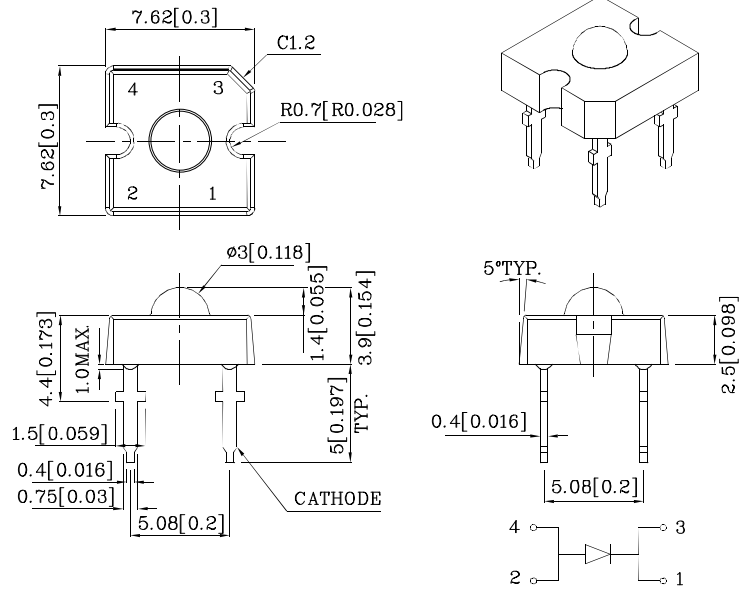

Notes:

1. All dimensions are in millimeters (inches).
2. Tolerance is $\pm 0.25(0.01)$ " unless otherwise noted.
3. Specifications are subject to change without notice.

Absolute Maximum Ratings ($T_A=25^\circ\text{C}$)		FWCB (InGaN)	Unit
Reverse Voltage	V_R	5	V
DC Forward Current	I_F	30	mA
Power Dissipation	P_D	126	mW
Operating Temperature	T_A	-40 ~ +85	°C
Storage Temperature	T_{stg}	-55 ~ +85	
Electrostatic Discharge Threshold (HBM)		250	V
Lead Solder Temperature [1.5mm Below Seating Plane.][1]		260°C For 5 Seconds	

1.No Reflow soldering .

Operating Characteristics ($T_A=25^\circ\text{C}$)		FWCB (InGaN)	Unit
Forward Voltage (Typ.) ($I_F=30\text{mA}$)	V_F	3.5	V
Forward Voltage (Max.) ($I_F=30\text{mA}$)	V_F	4.2	V
Reverse Current (Max.) ($V_R=5\text{V}$)	I_R	50	μA
Chromaticity Coordinates (Typ.)	x	0.31	
	y	0.31	
Capacitance (Typ.) ($V_F=0\text{V}$, $f=1\text{MHz}$)	C	100	pF
Thermal Resistance (Typ.)	$R_{\theta j-pin}$	180	°C/W

1.The dominant wavelength is derived from the CIE Chromaticity Diagram and represents the perceived color of the device.

Part Number	Emitting Color	Emitting Material	Lens-color	Luminous Intensity CIE127-2007* ($I_F=30\text{mA}$) cd		Luminous Flux CIE127-2007* ($I_F=30\text{mA}$) lm	Viewing Angle 2 θ 1/2
				min.	typ.	typ.	
XSFWCB983W	White	InGaN	Water Clear	3.6*	5.2*	7.2*	70°

1.Luminous intensity is measured with an integrating sphere after the device has stabilized.

2. θ 1/2 is the angle from optical centerline where the luminous intensity is 1/2 of the optical peak value.

3.LEDs are binned according to their Luminous intensity.

*Luminous intensity / luminous flux value is in accordance with CIE127-2007 standards.

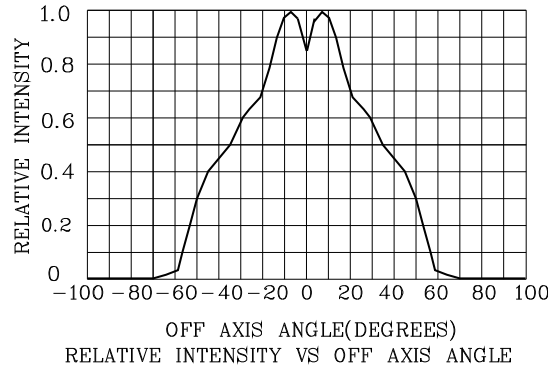

❖ FWCB

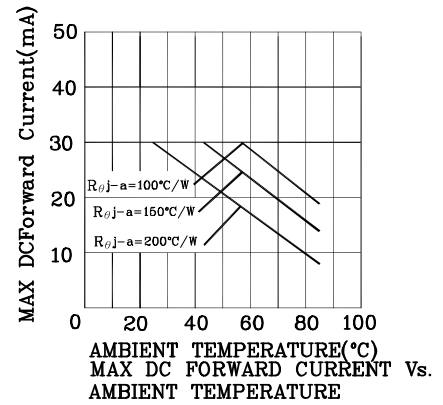
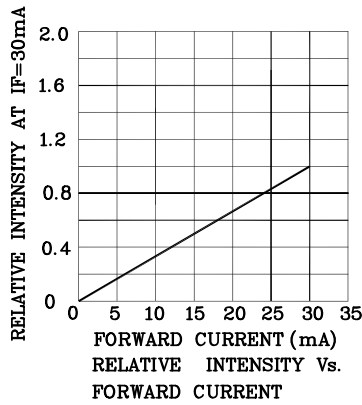
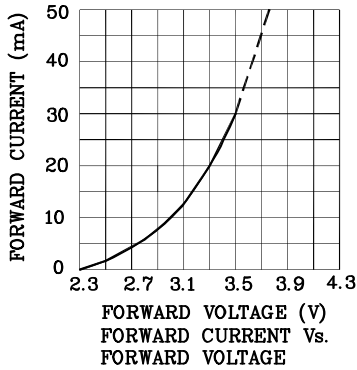

Wave Soldering Profile For Thru-Hole Products (Pb-Free Components)

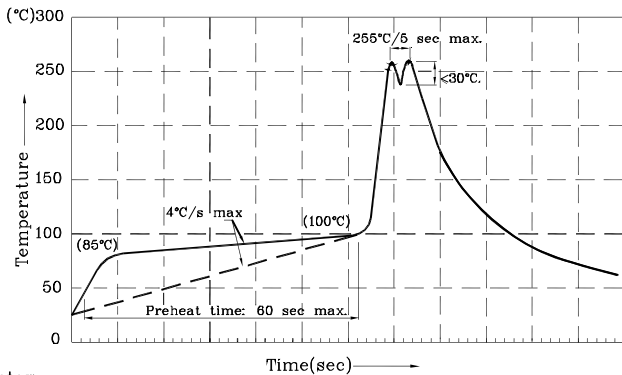

Remarks:

If special sorting is required (e.g. binning based on forward voltage, luminous intensity/ luminous flux or chromaticity), the typical accuracy of the sorting process is as follows:

1. Measurement tolerance of the chromaticity coordinates is ± 0.02 .
2. Luminous Intensity/ Luminous Flux: $\pm 15\%$
3. Forward Voltage: $\pm 0.1V$

Note: Accuracy may depend on the sorting parameters.

- Notes:
1. Recommend pre-heat temperature of 105°C or less (as measured with a thermocouple attached to the LED pins) prior to immersion in the solder wave with a maximum solder bath temperature of 260°C
 2. Peak wave soldering temperature between 245°C ~ 255°C for 3 sec (5 sec max).
 3. Do not apply stress to the epoxy resin while the temperature is above 85°C.
 4. Fixtures should not incur stress on the component when mounting and during soldering process.
 5. SAC 305 solder alloy is recommended.
 6. No more than one wave soldering pass.



XSFWCB983W

White CIE

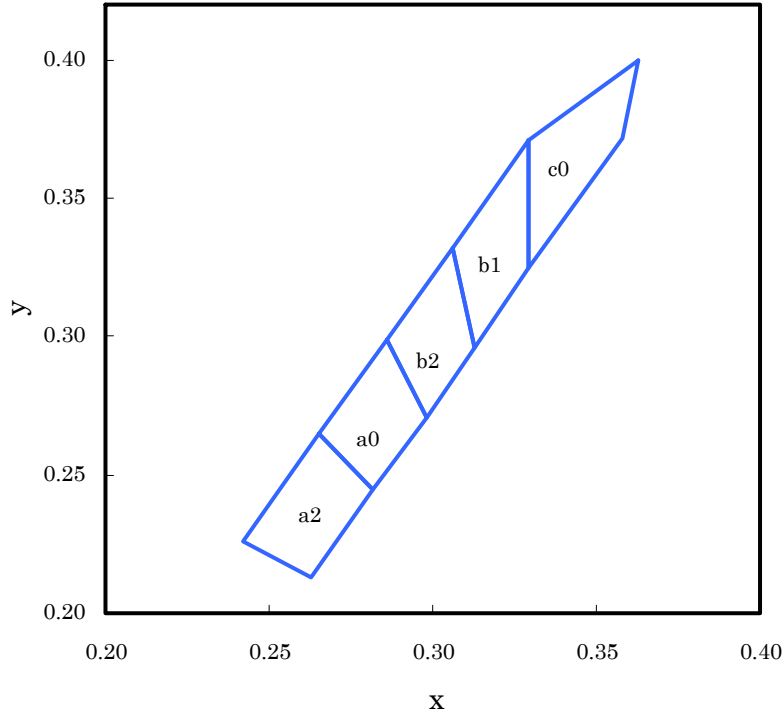

	x	y		x	y		x	y
a2	0.263	0.213	a0	0.282	0.245	b2	0.298	0.271
	0.282	0.245		0.298	0.271		0.313	0.296
	0.265	0.265		0.286	0.299		0.306	0.332
	0.242	0.226		0.265	0.265		0.286	0.299
b1	0.313	0.296	c0	0.329	0.325			
	0.329	0.325		0.358	0.372			
	0.329	0.371		0.363	0.400			
	0.306	0.332		0.329	0.371			

Notes:

Shipment may contain more than one chromaticity regions.
Orders for single chromaticity region are generally not accepted.
Measurement tolerance of the chromaticity coordinates is ± 0.02 .



PACKING & LABEL SPECIFICATIONS

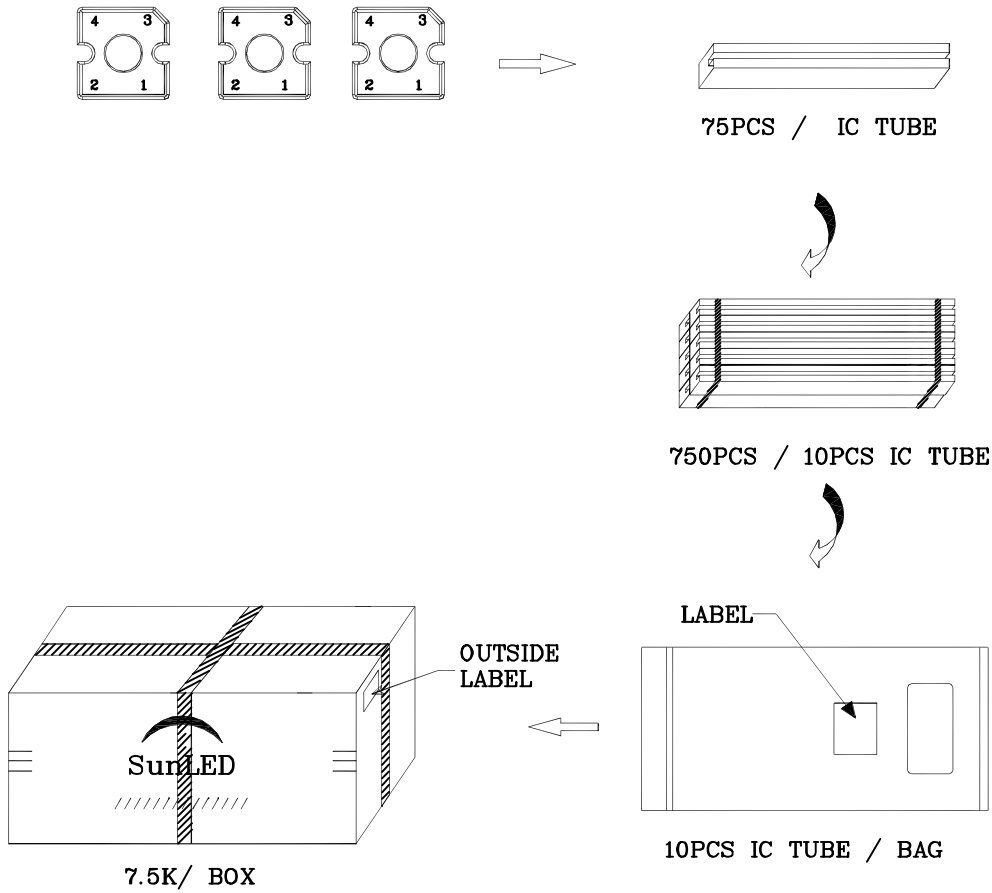



Q.C. Q.C

XX XX XXXX

PASSED

P/NO : XSxxx983x	
QTY : 750 pcs	CODE: XXX
S/N : XX	
LOT NO:	
 XXXXXXXXXXXXXXXXXXXXXXXXXXXX	
RoHS Compliant	