

Features

- BLACK CASE ENHANCES CONTRAST.
- VIBRATION AND SHOCK RESISTANT.
- UL RATING : 94V-0.
- HOUSING MATERIAL: TYPE 66 NYLON.
- 5V INTERNAL RESISTOR.
- RoHS COMPLIANT.

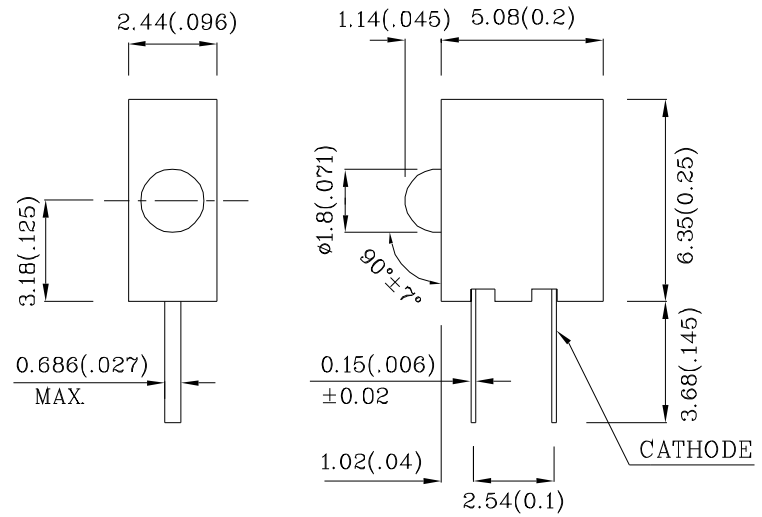

Notes:

1. All dimensions are in millimeters (inches).
2. Tolerance is $\pm 0.25(0.01)$ " unless otherwise noted.
3. Specifications are subject to change without notice.

Absolute maximum ratings (TA=25°C)		MR (GaAlAs)	Unit
Reverse Voltage	V _R	5	V
Forward Voltage	V _F	6	V
Power Dissipation	P _T	85	mW
Operating Temperature	T _A	-40 ~ +70	°C
Storage Temperature	T _{stg}	-40 ~ +85	
Lead Solder Temperature [2mm Below Package Base]	260°C For 3 Seconds		
Lead Solder Temperature [5mm Below Package Base]	260°C For 5 Seconds		

Operating Characteristics (TA=25°C)		MR (GaAlAs)	Unit
Forward Current (Typ.) (V _F =5V)	I _F	13	mA
Forward Current (Max.) (V _F =5V)	I _F	17.5	mA
Reverse Current (Max.) (V _R =5V)	I _R	10	uA
Wavelength of Peak Emission (Typ.) (V _F =5V)	λP	660	nm
Spectral Line Full Width At Half-Maximum (Typ.) (V _F =5V)	λD	640	nm
Spectral Line Half-Width (V _F =5V) (Typ.)	$\Delta\lambda$	20	nm

Part Number	Emitting Color	Emitting Material	Lens-color	Luminous Intensity (V=5V) mcd		Wavelength nm λP	Viewing Angle 2 θ 1/2
				min.	typ.		
XNH1ZMR46D5V	Red	GaAlAs	Red Diffused	40	148	660	40°
Published Date : JAN 17,2008 Drawing No : XDSA2712 V4 Checked : B.L.LIU P.1/4							

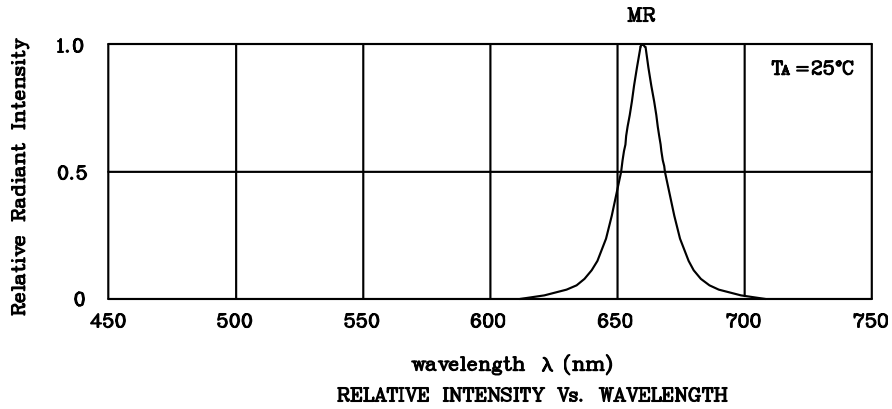

❖ MR

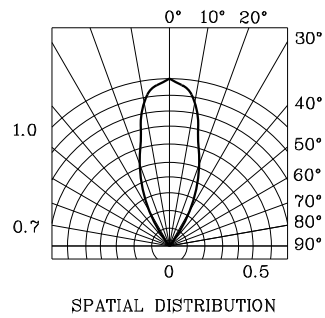
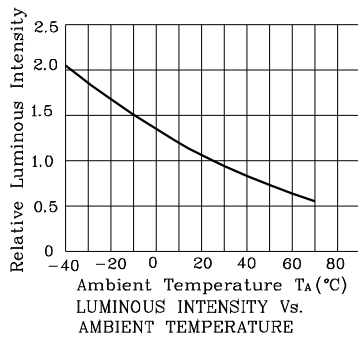
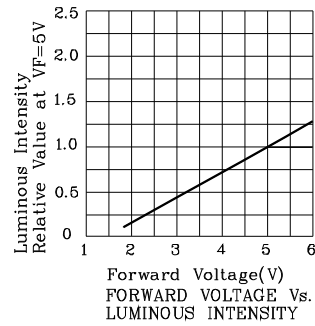
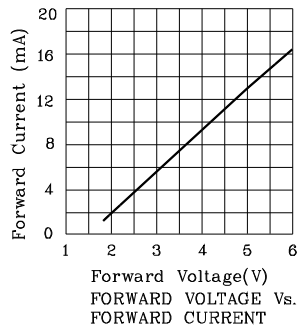

Wave Soldering Profile For Lead-free Through-hole LED.

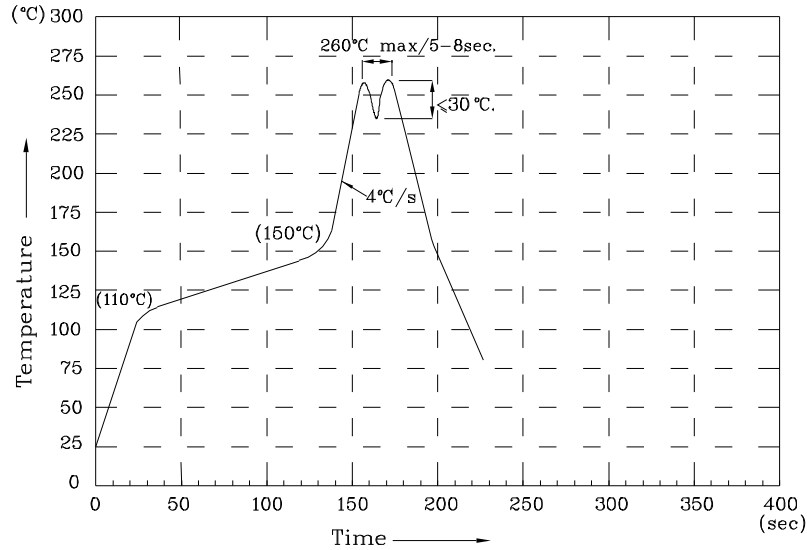

NOTES:

- 1.Recommend the wave temperature 245°C~260°C.The maximum soldering temperature should be less than 260°C.
- 2.Do not apply stress on epoxy resins when temperature is over 85 degree°C.
- 3.The soldering profile apply to the lead free soldering (Sn/Cu/Ag alloy).
- 4.No more than once.

Remarks:



If special sorting is required (e.g. binning based on luminous intensity / luminous flux or wavelength), the typical accuracy of the sorting process is as follows:



1. Wavelength: +/-1nm
2. Luminous Intensity / Luminous Flux: +/-15%

Note: Accuracy may depend on the sorting parameters.

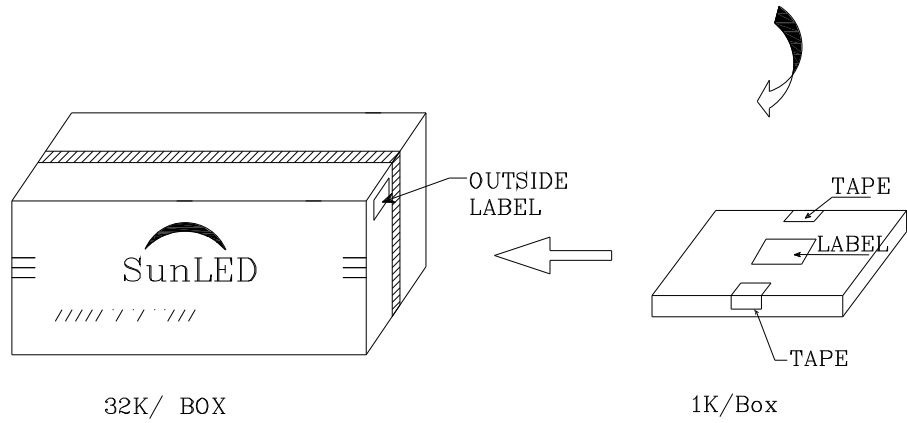
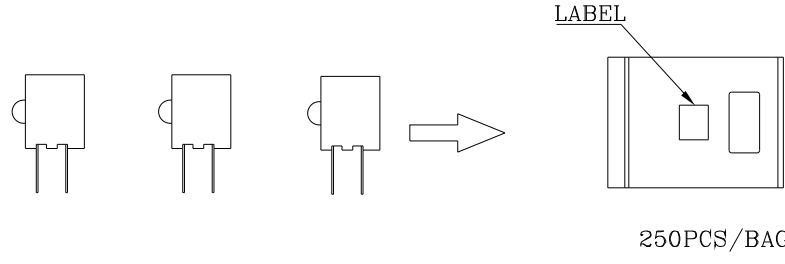
PACKING & LABEL SPECIFICATIONS

XNH1ZMR46D5V

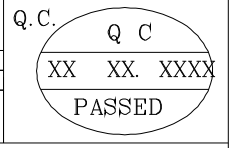
	
P/NO : XNH1Zxx46x	
QTY : 250 pcs	CODE: XXX
S/N : XX	
LOT NO:	
 xxxxxxxxxxxxxxxxxxxxxxxx	
RoHS Compliant	