

PS9305L

R08DS0013EJ0100

Rev.1.00

May 16, 2011

2.5 A OUTPUT CURRENT, HIGH CMR, IGBT GATE DRIVE, 8-PIN SDIP PHOTOCOUPLER

DESCRIPTION

The PS9305L is an optically coupled isolator containing a GaAlAs LED on the input side and a photo diode, a signal processing circuit and a power output transistor on the output side on one chip.

The PS9305L is designed specifically for high common mode transient immunity (CMR), high output current and high switching speed.

The PS9305L is suitable for driving IGBTs and MOS FETs.

FEATURES

- Long creepage distance (8 mm MIN.)
- Large peak output current (2.5 A MAX., 2.0 A MIN.)
- High speed switching (t_{PLH} , t_{PHL} = 0.25 μ s MAX.)
- UVLO (Under Voltage Lock Out) protection with hysteresis
- High common mode transient immunity (CM_H , CM_L = ± 25 kV/ μ s MIN.)
- <R> • Embossed tape product: PS9305L-E3: 2 000 pcs/reel
- <R> • Pb-Free product
- <R> • Safety standards
 - UL approved: No. E72422
 - CSA approved: No. CA 101391 (CA5A, CAN/CSA-C22.2 60065, 60950)
 - DIN EN60747-5-2 (VDE0884 Part2) approved: No. 40024069 (Option)

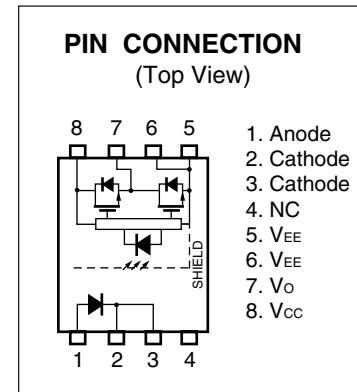

APPLICATIONS

- IGBT, Power MOS FET Gate Driver
- Industrial inverter
- IH (Induction Heating)

The mark <R> shows major revised points.

The revised points can be easily searched by copying an "<R>" in the PDF file and specifying it in the "Find what:" field.

PACKAGE DIMENSIONS (UNIT: mm)

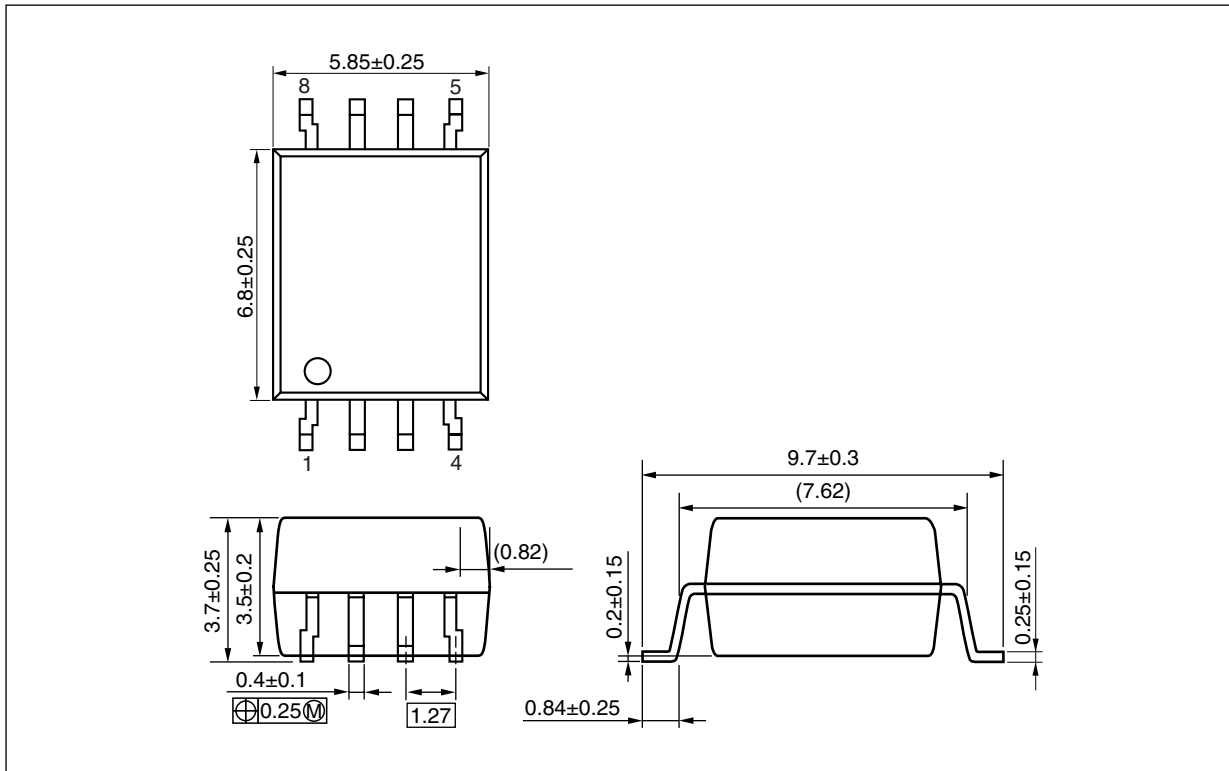

PHOTOCOUPLER CONSTRUCTION

Parameter	Unit (MIN.)
Air Distance	7 mm
Outer Creepage Distance	8 mm
Isolation Distance	0.4 mm

FUNCTIONAL DIAGRAM

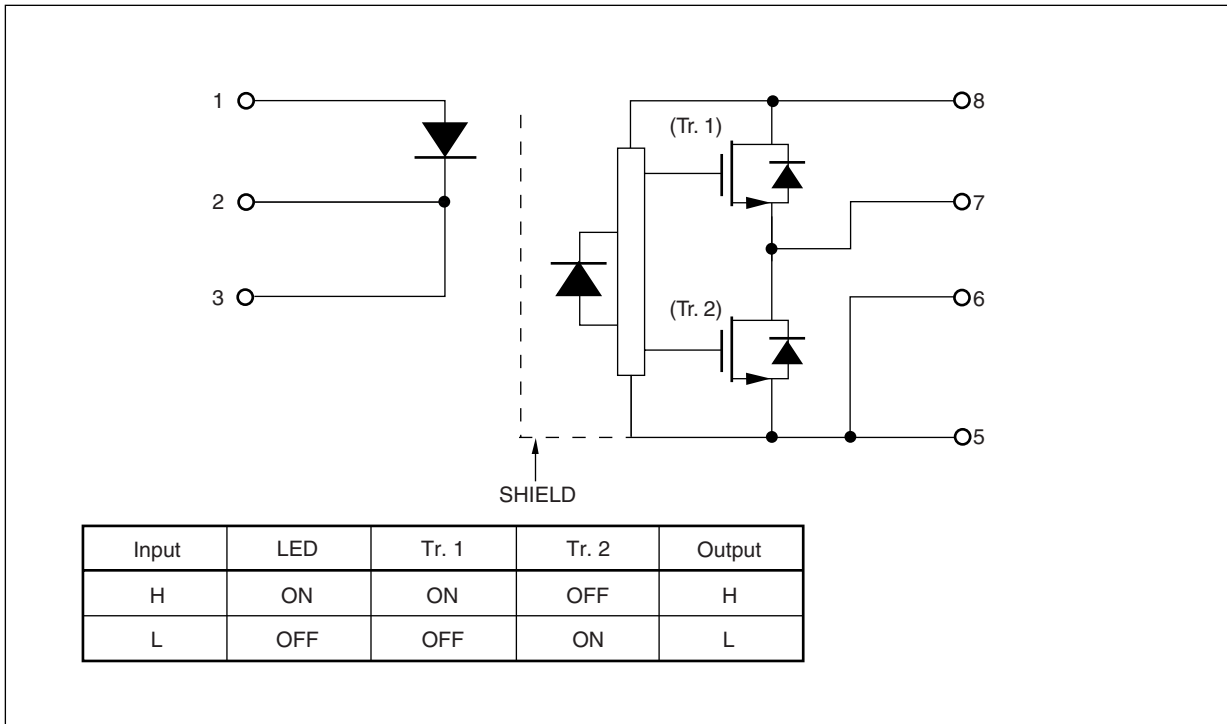

<R> MARKING EXAMPLE

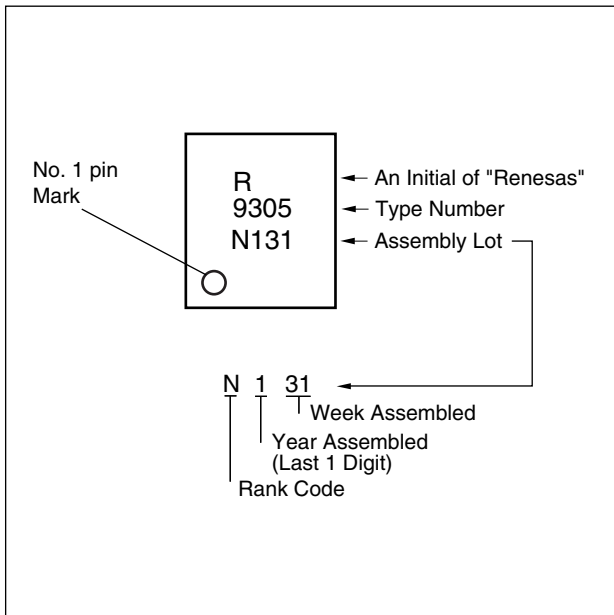

<R> ORDERING INFORMATION

Part Number	Order Number	Solder Plating Specification	Packing Style	Safety Standard Approval	Application Part Number* ¹
PS9305L	PS9305L-AX	Pb-Free (Ni/Pd/Au)	20 pcs (Tape 20 pcs cut)	Standard products (UL, CSA approved)	PS9305L
PS9305L-E3	PS9305L-E3-AX		Embossed Tape 2 000 pcs/reel		
PS9305L-V	PS9305L-V-AX		20 pcs (Tape 20 pcs cut)	DIN EN60747-5-2 (VDE0884 Part2) Approved (Option)	
PS9305L-V-E3	PS9305L-V-E3-AX		Embossed Tape 2 000 pcs/reel		

*1 For the application of the Safety Standard, following part number should be used.

ABSOLUTE MAXIMUM RATINGS (T_A = 25°C, unless otherwise specified)

Parameter		Symbol	Ratings	Unit
Diode	Forward Current	I _F	25	mA
	Peak Transient Forward Current (Pulse Width < 1 μs)	I _{F (TRAN)}	1.0	A
	Reverse Voltage	V _R	5	V
	Power Dissipation ^{*1}	P _D	45	mW
Detector	High Level Peak Output Current ^{*2}	I _{OH (PEAK)}	2.5	A
	Low Level Peak Output Current ^{*2}	I _{OL (PEAK)}	2.5	A
	Supply Voltage	(V _{CC} - V _{EE})	0 to 35	V
	Output Voltage	V _O	0 to V _{CC}	V
	Power Dissipation ^{*3}	P _C	250	mW
Isolation Voltage ^{*4}		BV	5 000	Vr.m.s.
Operating Frequency ^{*5}		f	50	kHz
Operating Ambient Temperature		T _A	-40 to +110	°C
Storage Temperature		T _{stg}	-55 to +125	°C

<R> *1 Reduced to 0.88 mW/°C at T_A = 85°C or more.

*2 Maximum pulse width = 10 μs, Maximum duty cycle = 0.2%

<R> *3 Reduced to 7.36 mW/°C at T_A = 85°C or more.

*4 AC voltage for 1 minute at T_A = 25°C, RH = 60% between input and output.

Pins 1-4 shorted together, 5-8 shorted together.

*5 I_{OH (PEAK)} ≤ 2.0 A (≤ 0.3 μs), I_{OL (PEAK)} ≤ 2.0 A (≤ 0.3 μs)

RECOMMENDED OPERATING CONDITIONS

Parameter	Symbol	MIN.	TYP.	MAX.	Unit
Supply Voltage	(V _{CC} - V _{EE})	15		30	V
Forward Current (ON)	I _{F (ON)}	7	10	16	mA
Forward Voltage (OFF)	V _{F (OFF)}	-2		0.8	V
Operating Ambient Temperature	T _A	-40		110	°C

ELECTRICAL CHARACTERISTICS

(V_{EE} = GND, unless otherwise specified and refer to RECOMMENDED OPERATING CONDITIONS)<R>
<R>

Parameter		Symbol	Conditions	MIN.	TYP. ^{*1}	MAX.	Unit
Diode	Forward Voltage	V _F	I _F = 10 mA, T _A = 25°C	1.2	1.56	1.8	V
	Reverse Current	I _R	V _R = 3 V, T _A = 25°C			10	μA
	Terminal Capacitance	C _t	f = 1 MHz, V _F = 0 V, T _A = 25°C		30		pF
Detector	High Level Output Current	I _{OH}	V _O = (V _{CC} - 4 V) ^{*2}	0.5	2.0		A
			V _O = (V _{CC} - 15 V) ^{*3}	2.0			
	Low Level Output Current	I _{OL}	V _O = (V _{EE} + 2.5 V) ^{*2}	0.5	2.0		A
			V _O = (V _{EE} + 15 V) ^{*3}	2.0			
	High Level Output Voltage	V _{OH}	I _O = -100 mA ^{*4}	V _{CC} - 3.0	V _{CC} - 1.5		V
	Low Level Output Voltage	V _{OL}	I _O = 100 mA		0.1	0.5	V
	High Level Supply Current	I _{CCH}	V _O = open, I _F = 10 mA		1.4	3.0	mA
	Low Level Supply Current	I _{CCL}	V _O = open, V _F = 0 to +0.8 V		1.3	3.0	mA
	UVLO Threshold	V _{UVLO+}	V _O > 5 V, I _F = 10 mA	10.8	12.3	13.4	V
		V _{UVLO-}		9.5	11.0	12.5	
UVLO Hysteresis	UVLO _{HYS}	V _O > 5 V, I _F = 10 mA	0.4	1.3		V	
Coupled	Threshold Input Current (L → H)	I _{FLH}	I _O = 0 mA, V _O > 5 V		2.0	5.0	mA
	Threshold Input Voltage (H → L)	V _{FHL}	I _O = 0 mA, V _O < 5 V	0.8			V

*1 Typical values at T_A = 25°C.

*2 Maximum pulse width = 50 μs, Maximum duty cycle = 0.5%.

*3 Maximum pulse width = 10 μs, Maximum duty cycle = 0.2%

*4 V_{OH} is measured with the DC load current in this testing (Maximum pulse width = 2 ms, Maximum duty cycle = 20%).

SWITCHING CHARACTERISTICS

(V_{EE} = GND, unless otherwise specified and refer to RECOMMENDED OPERATING CONDITIONS)

Parameter	Symbol	Conditions	MIN.	TYP.*1	MAX.	Unit	
Propagation Delay Time (L → H)	t _{PLH}	R _g = 10 Ω, C _g = 10 nF, f = 10 kHz, Duty Cycle = 50%*2, I _F = 10 mA		0.18	0.25	μs	
Propagation Delay Time (H → L)	t _{PHL}			0.18	0.25	μs	
Pulse Width Distortion (PWD)	t _{PHL} - t _{PLH}				0.02	0.1	μs
Propagation Delay Time (Difference Between Any Two Products)	t _{PHL} - t _{PLH}			-0.1		0.1	μs
Rise Time	t _r				50		ns
Fall Time	t _f				50		ns
UVLO (Turn On Delay)	t _{UVLO ON}	V _O > 5 V, I _F = 10 mA		0.8		μs	
UVLO (Turn Off Delay)	t _{UVLO OFF}	V _O < 5 V, I _F = 10 mA		0.6		μs	
Common Mode Transient Immunity at High Level Output	CM _H	T _A = 25°C, I _F = 10 mA, V _{CC} = 30 V, V _{O (MIN.)} = 26 V, V _{CM} = 1.5 kV	25			kV/μs	
Common Mode Transient Immunity at Low Level Output	CM _L	T _A = 25°C, I _F = 0 mA, V _{CC} = 30 V, V _{O (MAX.)} = 1 V, V _{CM} = 1.5 kV	25			kV/μs	

*1 Typical values at T_A = 25°C.

*2 This load condition is equivalent to the IGBT load at 1 200 V/75 A.

<R> TEST CIRCUIT

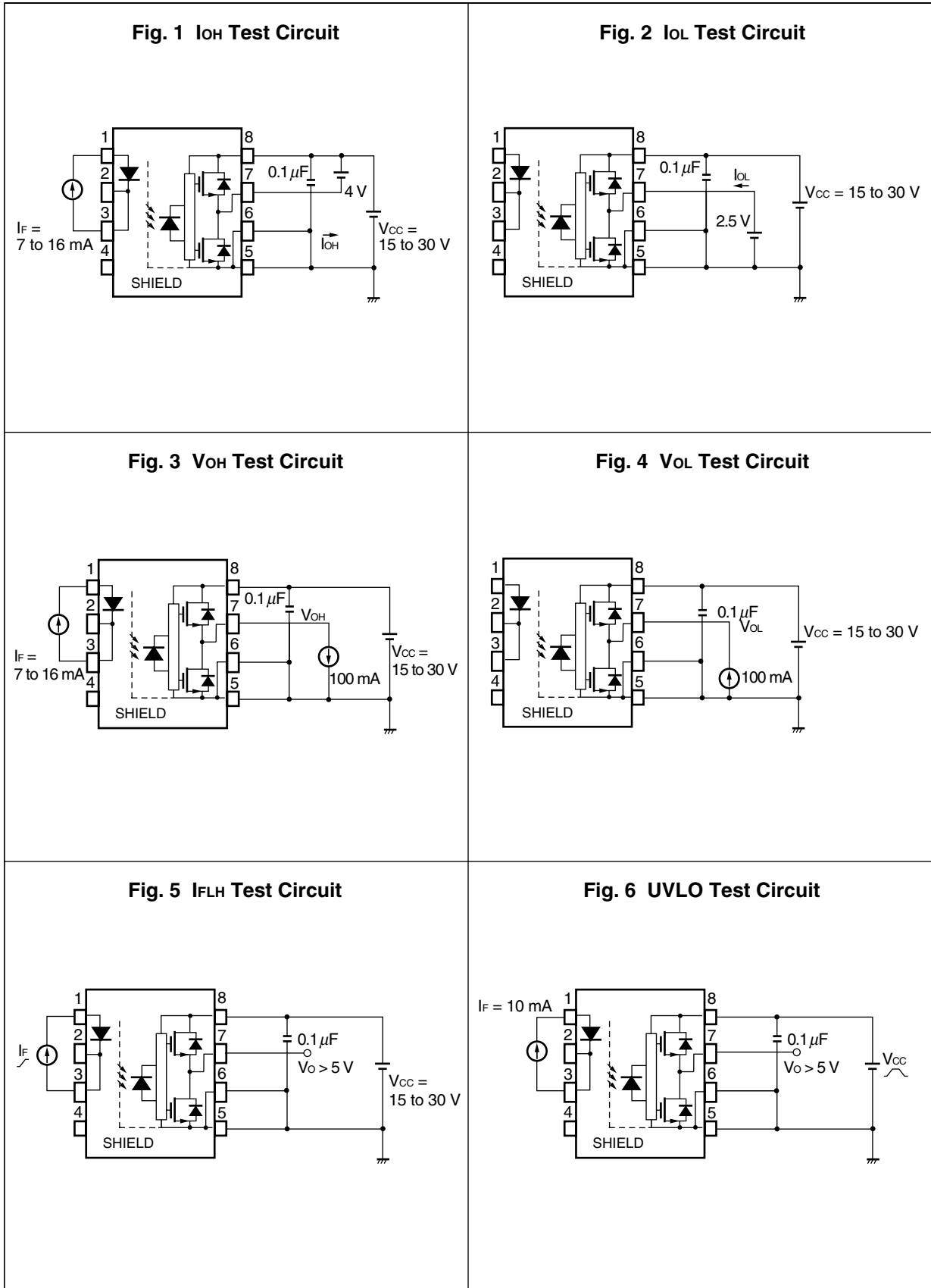

Fig. 7 t_{PLH}, t_{PHL}, t_r, t_f Test Circuit and Wave Forms

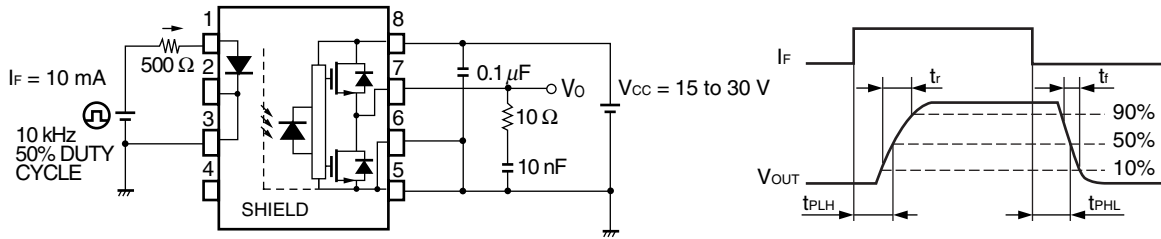
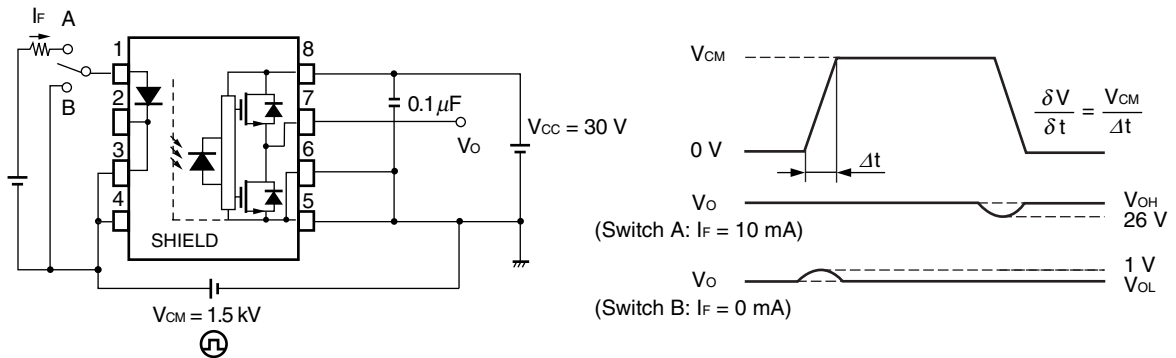
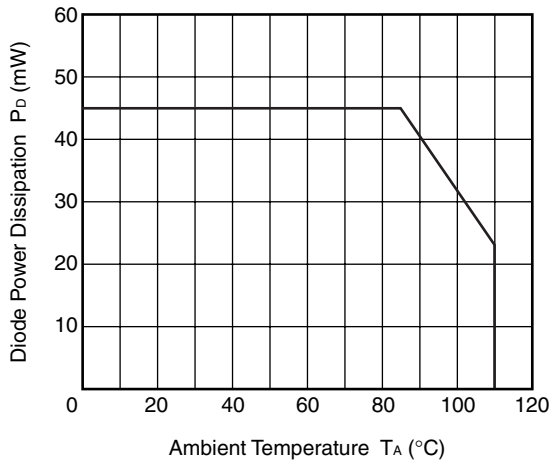

Fig. 8 CMR Test Circuit and Wave Forms



<R> TYPICAL CHARACTERISTICS (T_A = 25°C, unless otherwise specified)

DIODE POWER DISSIPATION vs. AMBIENT TEMPERATURE



DETECTOR POWER DISSIPATION vs. AMBIENT TEMPERATURE

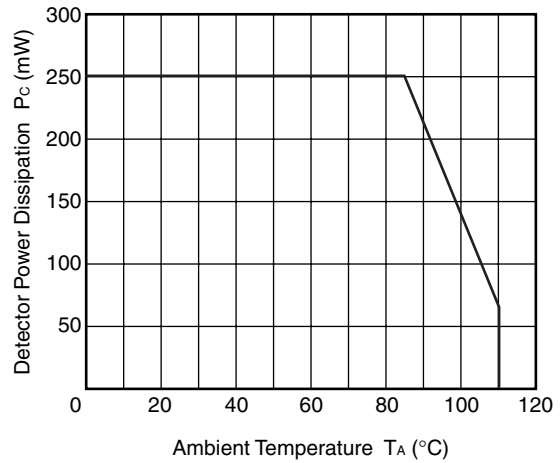

FORWARD CURRENT vs. FORWARD VOLTAGE

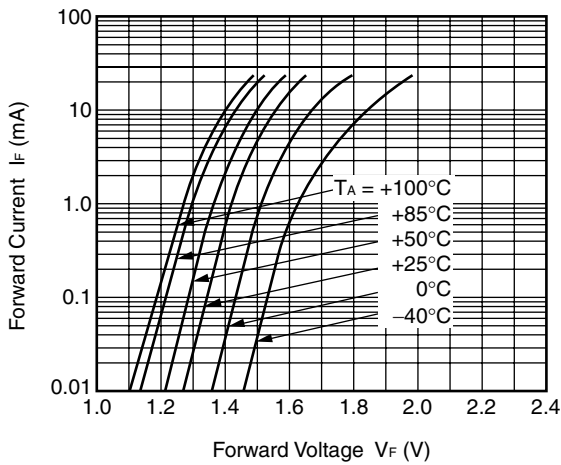

THRESHOLD INPUT CURRENT vs. AMBIENT TEMPERATURE

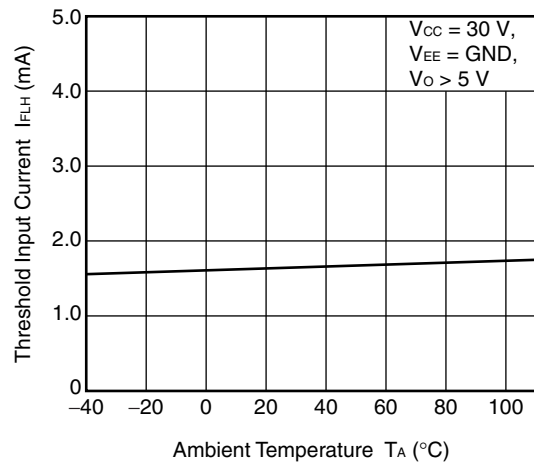

OUTPUT VOLTAGE vs. FORWARD CURRENT

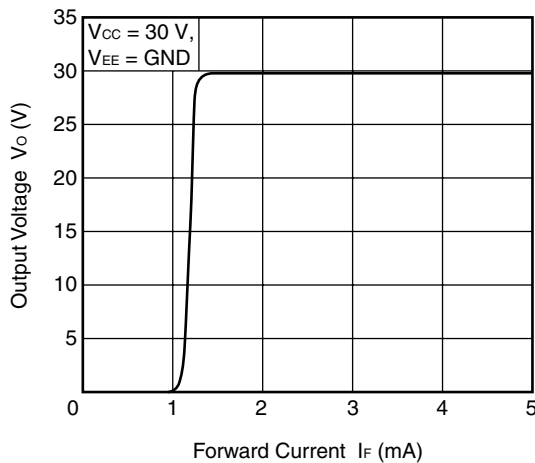

HIGH LEVEL OUTPUT VOLTAGE – SUPPLY VOLTAGE vs. HIGH LEVEL OUTPUT CURRENT

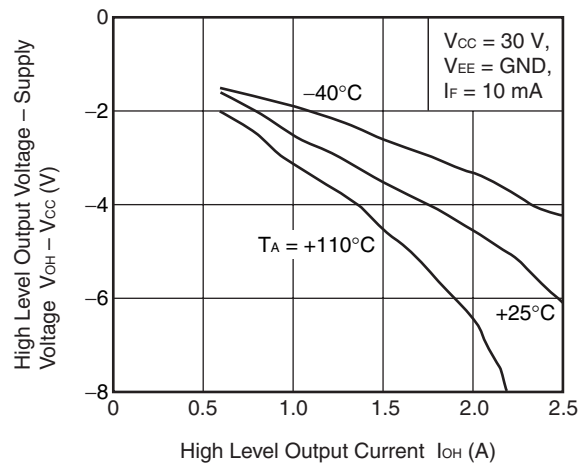

Remark The graphs indicate nominal characteristics.

LOW LEVEL OUTPUT VOLTAGE vs. LOW LEVEL OUTPUT CURRENT

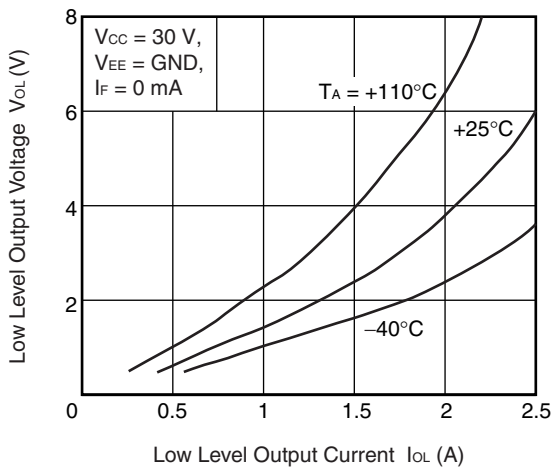

PROPAGATION DELAY TIME, PULSE WIDTH DISTORTION vs. FORWARD CURRENT

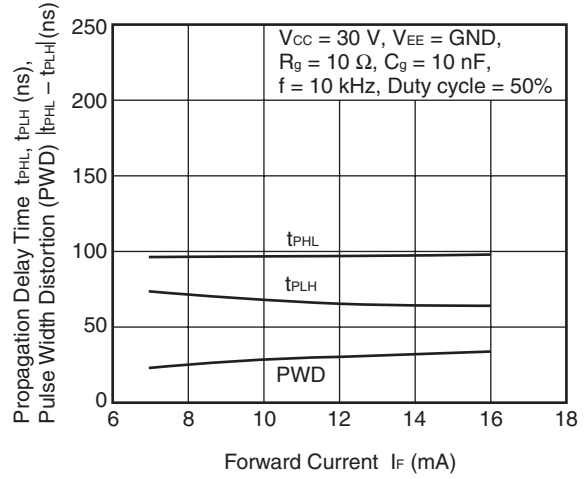

PROPAGATION DELAY TIME, PULSE WIDTH DISTORTION vs. SUPPLY VOLTAGE

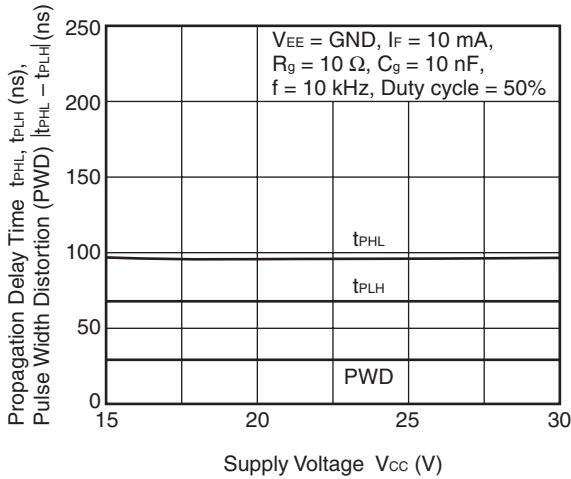

PROPAGATION DELAY TIME, PULSE WIDTH DISTORTION vs. LOAD CAPACITANCE

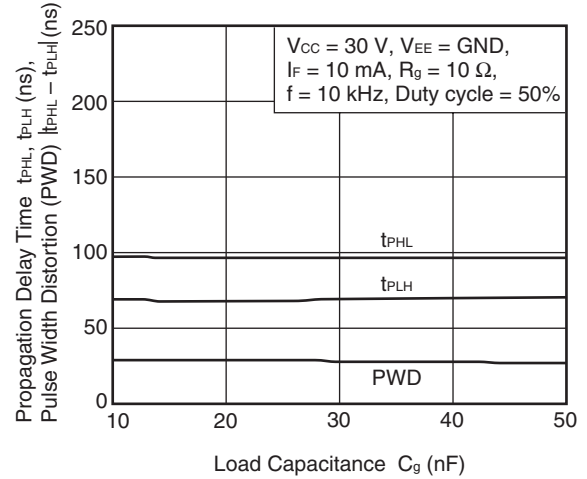

PROPAGATION DELAY TIME, PULSE WIDTH DISTORTION vs. LOAD RESISTANCE

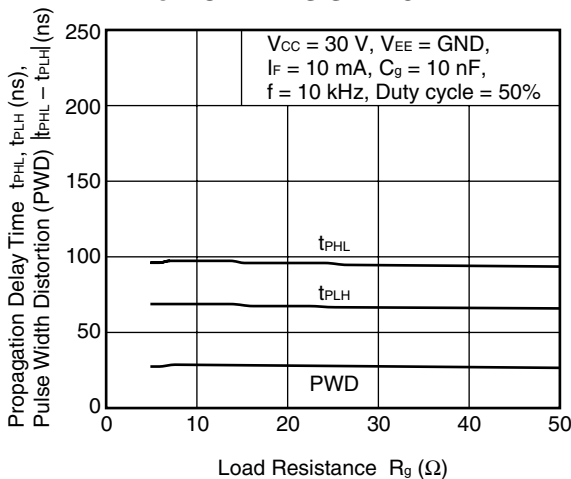

PROPAGATION DELAY TIME, PULSE WIDTH DISTORTION vs. AMBIENT TEMPERATURE

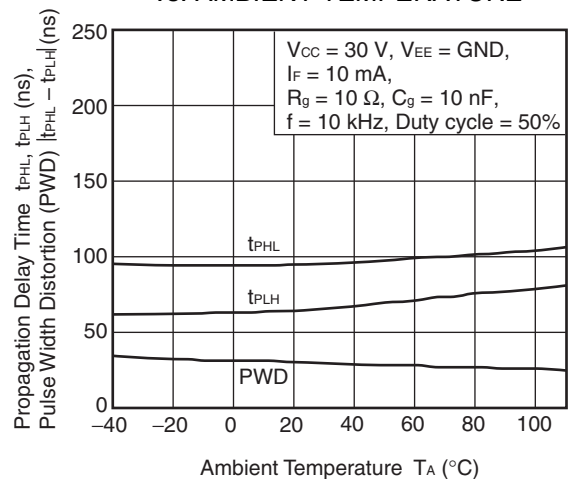

Remark The graphs indicate nominal characteristics.

SUPPLY CURRENT vs. AMBIENT TEMPERATURE

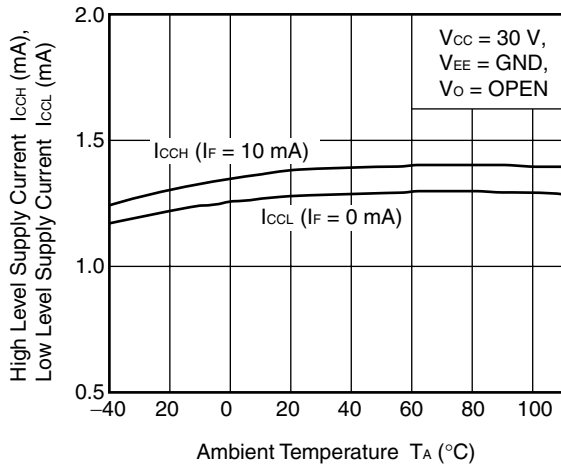

SUPPLY CURRENT vs. SUPPLY VOLTAGE

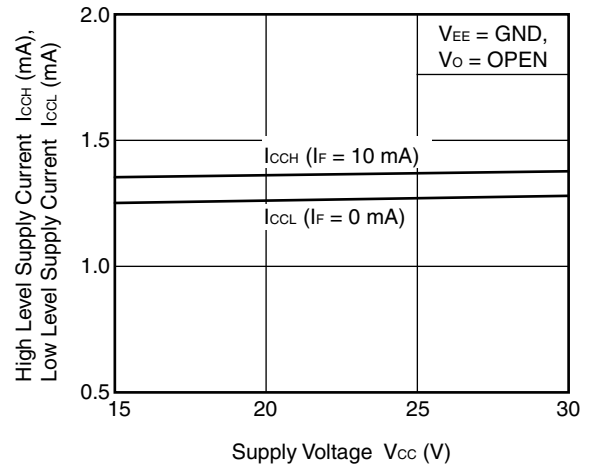

HIGH LEVEL OUTPUT VOLTAGE – SUPPLY VOLTAGE vs. AMBIENT TEMPERATURE

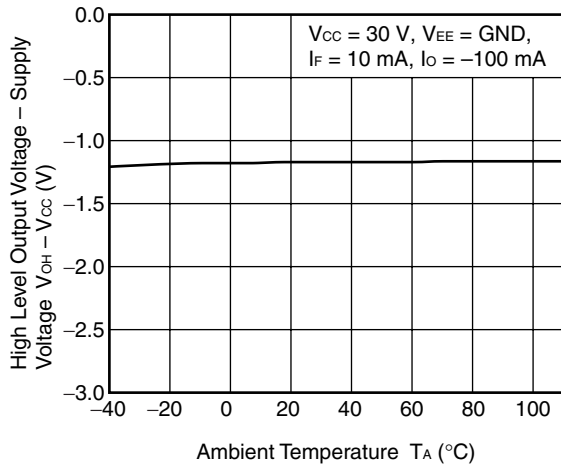

LOW LEVEL OUTPUT VOLTAGE vs. AMBIENT TEMPERATURE

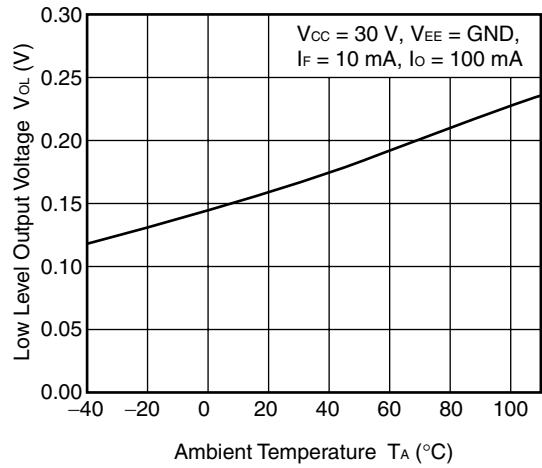

HIGH LEVEL OUTPUT CURRENT vs. AMBIENT TEMPERATURE

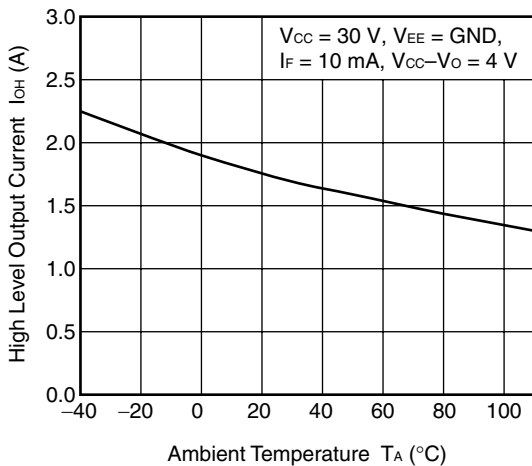

LOW LEVEL OUTPUT CURRENT vs. AMBIENT TEMPERATURE

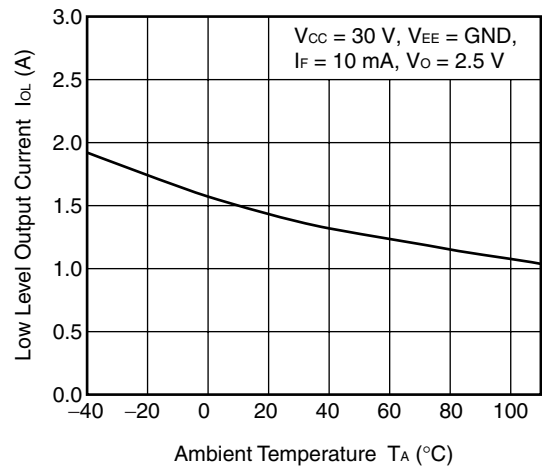

Remark The graphs indicate nominal characteristics.

OUTPUT VOLTAGE vs. SUPPLY VOLTAGE

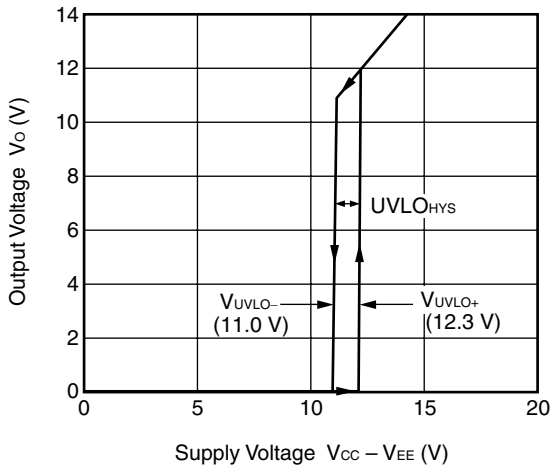

Remark The graph indicates nominal characteristics.

<R> TAPING SPECIFICATIONS (UNIT: mm)

Outline and Dimensions (Tape)

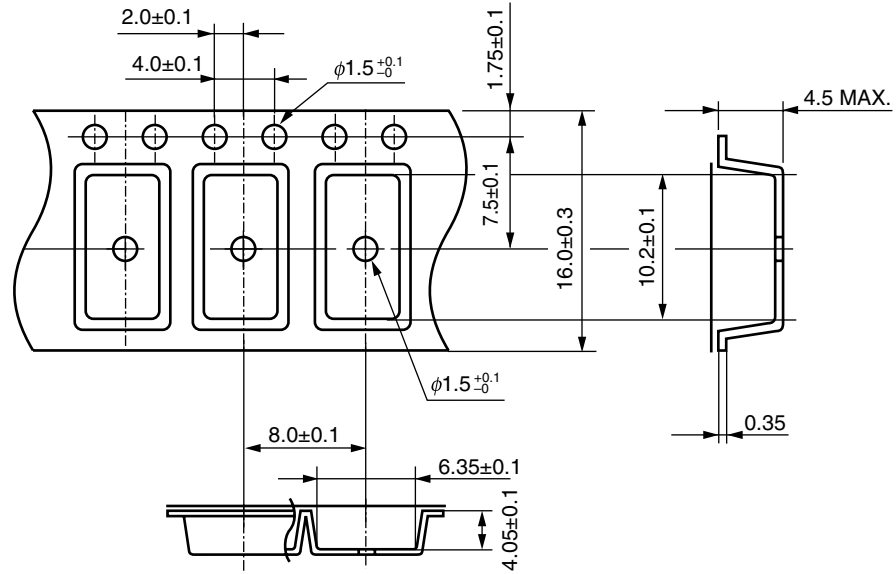

Tape Direction

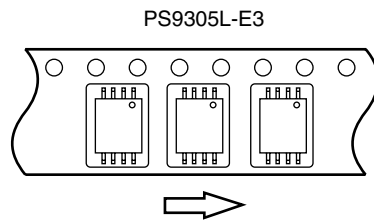

Outline and Dimensions (Reel)

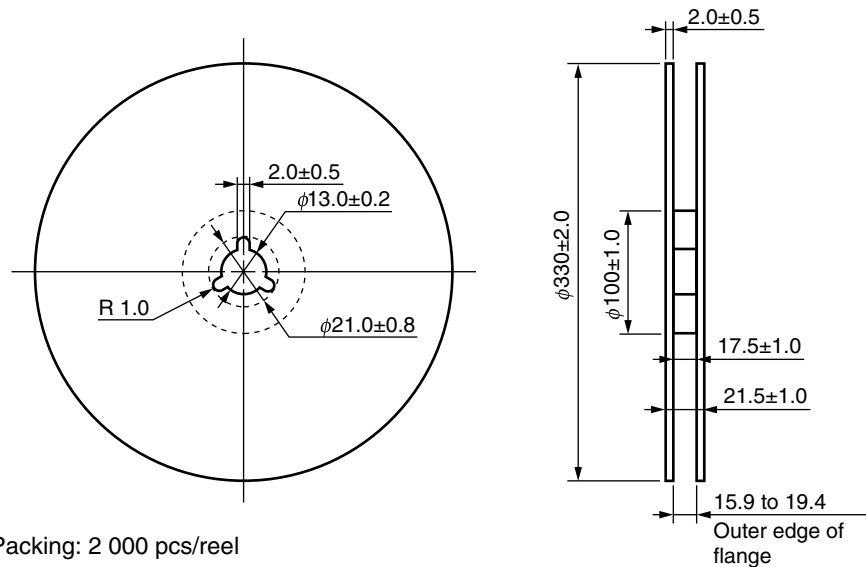

Packing: 2 000 pcs/reel

<R> RECOMMENDED MOUNT PAD DIMENSIONS (UNIT: mm)

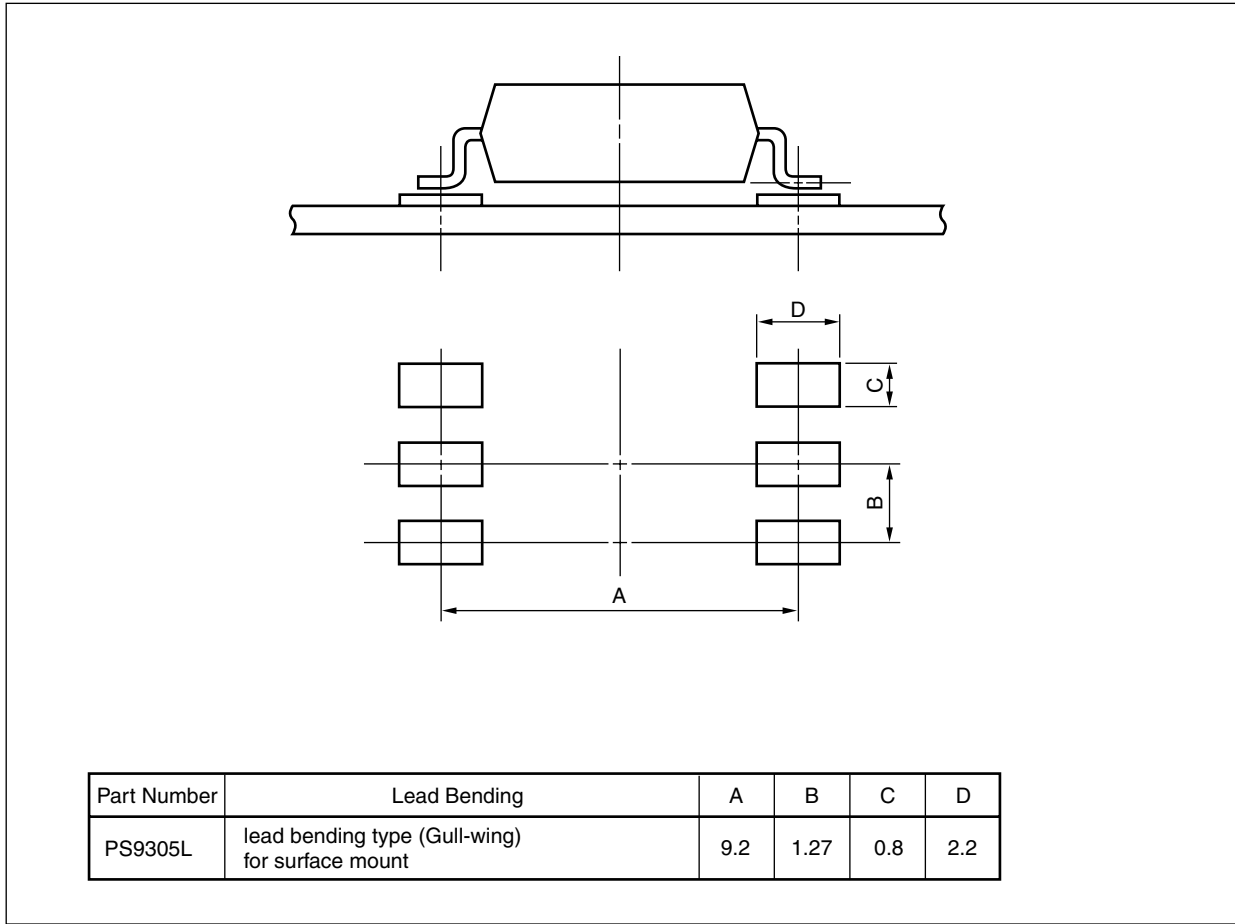

<R> NOTES ON HANDLING

1. Recommended soldering conditions**(1) Infrared reflow soldering**

- Peak reflow temperature 260°C or below (package surface temperature)
- Time of peak reflow temperature 10 seconds or less
- Time of temperature higher than 220°C 60 seconds or less
- Time to preheat temperature from 120 to 180°C 120±30 s
- Number of reflows Three
- Flux Rosin flux containing small amount of chlorine (The flux with a maximum chlorine content of 0.2 Wt% is recommended.)

Recommended Temperature Profile of Infrared Reflow

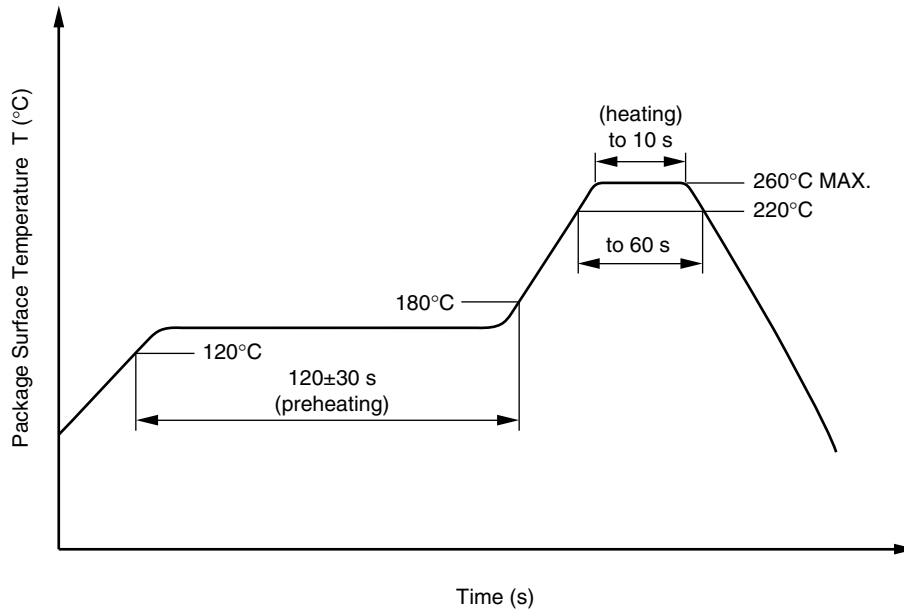
**(2) Wave soldering**

- Temperature 260°C or below (molten solder temperature)
- Time 10 seconds or less
- Preheating conditions 120°C or below (package surface temperature)
- Number of times One (Allowed to be dipped in solder including plastic mold portion.)
- Flux Rosin flux containing small amount of chlorine (The flux with a maximum chlorine content of 0.2 Wt% is recommended.)

(3) Soldering by Soldering Iron

- Peak Temperature (lead part temperature) 350°C or below
- Time (each pins) 3 seconds or less
- Flux Rosin flux containing small amount of chlorine (The flux with a maximum chlorine content of 0.2 Wt% is recommended.)

(a) Soldering of leads should be made at the point 1.5 to 2.0 mm from the root of the lead

(4) Cautions

- Fluxes

Avoid removing the residual flux with freon-based and chlorine-based cleaning solvent.

2. Cautions regarding noise

Be aware that when voltage is applied suddenly between the photocoupler's input and output at startup, the output transistor may enter the on state, even if the voltage is within the absolute maximum ratings.

USAGE CAUTIONS

1. This product is weak for static electricity by designed with high-speed integrated circuit so protect against static electricity when handling.
2. Board designing
 - (1) By-pass capacitor of more than 0.1 μF is used between V_{CC} and GND near device. Also, ensure that the distance between the leads of the photocoupler and capacitor is no more than 10 mm.
 - (2) In order to avoid malfunctions and characteristics degradation, IGBT collector or emitter traces should not be closed to the LED input.
 - (3) Pin 4 (which is an NC^{*1} pin) can either be connected directly to the GND pin on the LED side or left open.
Unconnected pins should not be used as a bypass for signals or for any other similar purpose because this may degrade the internal noise environment of the device.
***1** NC: Non-Connection (No Connection)
3. Make sure the rise/fall time of the forward current is 0.5 μs or less.
4. In order to avoid malfunctions, make sure the rise/fall slope of the supply voltage is 3 V/ μs or less.
5. Avoid storage at a high temperature and high humidity.

<R>

SPECIFICATION OF VDE MARKS LICENSE DOCUMENT

Parameter	Symbol	Spec.	Unit
Climatic test class (IEC 60068-1/DIN EN 60068-1)		40/110/21	
Dielectric strength			
maximum operating isolation voltage	U_{IORM}	1 130	V_{peak}
Test voltage (partial discharge test, procedure a for type test and random test) $U_{pr} = 1.5 \times U_{IORM}$, $P_d < 5$ pC	U_{pr}	1 695	V_{peak}
Test voltage (partial discharge test, procedure b for all devices) $U_{pr} = 1.875 \times U_{IORM}$, $P_d < 5$ pC	U_{pr}	2 119	V_{peak}
Highest permissible overvoltage	U_{TR}	8 000	V_{peak}
Degree of pollution (DIN EN 60664-1 VDE0110 Part 1)		2	
Comparative tracking index (IEC 60112/DIN EN 60112 (VDE 0303 Part 11))	CTI	175	
Material group (DIN EN 60664-1 VDE0110 Part 1)		III a	
Storage temperature range	T_{stg}	-55 to +125	°C
Operating temperature range	T_A	-40 to +110	°C
Isolation resistance, minimum value $V_{IO} = 500$ V dc at $T_A = 25^\circ\text{C}$ $V_{IO} = 500$ V dc at T_A MAX. at least 100°C	Ris MIN. Ris MIN.	10^{12} 10^{11}	Ω Ω
Safety maximum ratings (maximum permissible in case of fault, see thermal derating curve)			
Package temperature	T_{si}	175	°C
Current (input current I_F , $P_{si} = 0$)	I_{si}	400	mA
Power (output or total power dissipation)	P_{si}	700	mW
Isolation resistance $V_{IO} = 500$ V dc at $T_A = T_{si}$	Ris MIN.	10^9	Ω

Caution GaAs Products	<p>This product uses gallium arsenide (GaAs). GaAs vapor and powder are hazardous to human health if inhaled or ingested, so please observe the following points.</p> <ul style="list-style-type: none">• Follow related laws and ordinances when disposing of the product. If there are no applicable laws and/or ordinances, dispose of the product as recommended below.<ol style="list-style-type: none">1. Commission a disposal company able to (with a license to) collect, transport and dispose of materials that contain arsenic and other such industrial waste materials.2. Exclude the product from general industrial waste and household garbage, and ensure that the product is controlled (as industrial waste subject to special control) up until final disposal.• Do not burn, destroy, cut, crush, or chemically dissolve the product.• Do not lick the product or in any way allow it to enter the mouth.
------------------------------	--

Revision History

PS9305L Data Sheet

Rev.	Date	Description	
		Page	Summary
0.01	May 12, 2010	–	First Edition issued
1.00	May 16, 2011	Throughout	Preliminary Data Sheet -> Data Sheet
		Throughout	Safety standards approved
		p.3	Modification of MARKING EXAMPLE
		p.4	Addition of ORDERING INFORMATION
		p.4	Modification of ABSOLUTE MAXIMUM RATINGS
		p.5	Modification of ELECTRICAL CHARACTERISTICS I_{CCH} , I_{CCL}
		p.6	Modification of SWITCHING CHARACTERISTICS $ t_{PHL}-t_{PLH} $
		pp.7, 8	Addition of TEST CIRCUIT
		pp.9 to 12	Addition of TYPICAL CHARACTERISTICS
		p.13	Addition of TAPING SPECIFICATIONS
		p.14	Addition of RECOMMENDED MOUNT PAD DIMENSIONS
		pp.15, 16	Addition of NOTES ON HANDLING
		p.17	Addition of SPECIFICATION OF VDE MARKS LICENSE DOCUMENT

All trademarks and registered trademarks are the property of their respective owners.

Notice

- All information included in this document is current as of the date this document is issued. Such information, however, is subject to change without any prior notice. Before purchasing or using any Renesas Electronics products listed herein, please confirm the latest product information with a Renesas Electronics sales office. Also, please pay regular and careful attention to additional and different information to be disclosed by Renesas Electronics such as that disclosed through our website.
 - Renesas Electronics does not assume any liability for infringement of patents, copyrights, or other intellectual property rights of third parties by or arising from the use of Renesas Electronics products or technical information described in this document. No license, express, implied or otherwise, is granted hereby under any patents, copyrights or other intellectual property rights of Renesas Electronics or others.
 - You should not alter, modify, copy, or otherwise misappropriate any Renesas Electronics product, whether in whole or in part.
 - Descriptions of circuits, software and other related information in this document are provided only to illustrate the operation of semiconductor products and application examples. You are fully responsible for the incorporation of these circuits, software, and information in the design of your equipment. Renesas Electronics assumes no responsibility for any losses incurred by you or third parties arising from the use of these circuits, software, or information.
 - When exporting the products or technology described in this document, you should comply with the applicable export control laws and regulations and follow the procedures required by such laws and regulations. You should not use Renesas Electronics products or the technology described in this document for any purpose relating to military applications or use by the military, including but not limited to the development of weapons of mass destruction. Renesas Electronics products and technology may not be used for or incorporated into any products or systems whose manufacture, use, or sale is prohibited under any applicable domestic or foreign laws or regulations.
 - Renesas Electronics has used reasonable care in preparing the information included in this document, but Renesas Electronics does not warrant that such information is error free. Renesas Electronics assumes no liability whatsoever for any damages incurred by you resulting from errors in or omissions from the information included herein.
 - Renesas Electronics products are classified according to the following three quality grades: "Standard", "High Quality", and "Specific". The recommended applications for each Renesas Electronics product depends on the product's quality grade, as indicated below. You must check the quality grade of each Renesas Electronics product before using it in a particular application. You may not use any Renesas Electronics product for any application categorized as "Specific" without the prior written consent of Renesas Electronics. Further, you may not use any Renesas Electronics product for any application for which it is not intended without the prior written consent of Renesas Electronics. Renesas Electronics shall not be in any way liable for any damages or losses incurred by you or third parties arising from the use of any Renesas Electronics product for an application categorized as "Specific" or for which the product is not intended where you have failed to obtain the prior written consent of Renesas Electronics. The quality grade of each Renesas Electronics product is "Standard" unless otherwise expressly specified in a Renesas Electronics data sheets or data books, etc.
"Standard": Computers; office equipment; communications equipment; test and measurement equipment; audio and visual equipment; home electronic appliances; machine tools; personal electronic equipment; and industrial robots.
"High Quality": Transportation equipment (automobiles, trains, ships, etc.); traffic control systems; anti-disaster systems; anti-crime systems; safety equipment; and medical equipment not specifically designed for life support.
"Specific": Aircraft; aerospace equipment; submersible repeaters; nuclear reactor control systems; medical equipment or systems for life support (e.g. artificial life support devices or systems), surgical implantations, or healthcare intervention (e.g. excision, etc.), and any other applications or purposes that pose a direct threat to human life.
 - You should use the Renesas Electronics products described in this document within the range specified by Renesas Electronics, especially with respect to the maximum rating, operating supply voltage range, movement power voltage range, heat radiation characteristics, installation and other product characteristics. Renesas Electronics shall have no liability for malfunctions or damages arising out of the use of Renesas Electronics products beyond such specified ranges.
 - Although Renesas Electronics endeavors to improve the quality and reliability of its products, semiconductor products have specific characteristics such as the occurrence of failure at a certain rate and malfunctions under certain use conditions. Further, Renesas Electronics products are not subject to radiation resistance design. Please be sure to implement safety measures to guard them against the possibility of physical injury, and injury or damage caused by fire in the event of the failure of a Renesas Electronics product, such as safety design for hardware and software including but not limited to redundancy, fire control and malfunction prevention, appropriate treatment for aging degradation or any other appropriate measures. Because the evaluation of microcomputer software alone is very difficult, please evaluate the safety of the final products or system manufactured by you.
 - Please contact a Renesas Electronics sales office for details as to environmental matters such as the environmental compatibility of each Renesas Electronics product. Please use Renesas Electronics products in compliance with all applicable laws and regulations that regulate the inclusion or use of controlled substances, including without limitation, the EU RoHS Directive. Renesas Electronics assumes no liability for damages or losses occurring as a result of your noncompliance with applicable laws and regulations.
 - This document may not be reproduced or duplicated, in any form, in whole or in part, without prior written consent of Renesas Electronics.
 - Please contact a Renesas Electronics sales office if you have any questions regarding the information contained in this document or Renesas Electronics products, or if you have any other inquiries.
- (Note 1) "Renesas Electronics" as used in this document means Renesas Electronics Corporation and also includes its majority-owned subsidiaries.
(Note 2) "Renesas Electronics product(s)" means any product developed or manufactured by or for Renesas Electronics.



SALES OFFICES

Renesas Electronics Corporation

<http://www.renesas.com>

Refer to "<http://www.renesas.com/>" for the latest and detailed information.

Renesas Electronics America Inc.
2880 Scott Boulevard Santa Clara, CA 95050-2554, U.S.A.
Tel: +1-408-586-6000, Fax: +1-408-588-6130

Renesas Electronics Canada Limited
1101 Nicholson Road, Newmarket, Ontario L3Y 9C3, Canada
Tel: +1-905-898-5441, Fax: +1-905-898-3220

Renesas Electronics Europe Limited
Dukes Meadow, Millboard Road, Bourne End, Buckinghamshire, SL8 5FH, U.K
Tel: +44-1628-585-100, Fax: +44-1628-585-900

Renesas Electronics Europe GmbH
Arcadiastrasse 10, 40472 Düsseldorf, Germany
Tel: +49-211-65030, Fax: +49-211-6503-1327

Renesas Electronics (China) Co., Ltd.
7th Floor, Quantum Plaza, No.27 ZhiChunLu Haidian District, Beijing 100083, P.R.China
Tel: +86-10-8235-1155, Fax: +86-10-8235-7679

Renesas Electronics (Shanghai) Co., Ltd.
Unit 204, 205, AZIA Center, No.1233 Lujiazui Ring Rd., Pudong District, Shanghai 200120, China
Tel: +86-21-5877-1818, Fax: +86-21-6887-7858 / -7898

Renesas Electronics Hong Kong Limited
Unit 1601-1613, 16/F., Tower 2, Grand Century Place, 193 Prince Edward Road West, Mongkok, Kowloon, Hong Kong
Tel: +852-2886-9318, Fax: +852 2886-9022/9044

Renesas Electronics Taiwan Co., Ltd.
7F, No. 363 Fu Shing North Road Taipei, Taiwan
Tel: +886-2-8175-9600, Fax: +886 2-8175-9670

Renesas Electronics Singapore Pte. Ltd.
1 HarbourFront Avenue, #06-10, Keppel Bay Tower, Singapore 098632
Tel: +65-6213-0200, Fax: +65-6276-8001

Renesas Electronics Malaysia Sdn.Bhd.
Unit 906, Block B, Menara Amcorp, Amcorp Trade Centre, No. 18, Jln Persiaran Barat, 46050 Petaling Jaya, Selangor Darul Ehsan, Malaysia
Tel: +60-3-7955-9390, Fax: +60-3-7955-9510

Renesas Electronics Korea Co., Ltd.
11F., Samik Lavied' or Bldg., 720-2 Yeoksam-Dong, Kangnam-Ku, Seoul 135-080, Korea
Tel: +82-2-558-3737, Fax: +82-2-558-5141