

PART NAME

NEMA 4X DIE CAST ALUMINUM ENCLOSURE

PART No.

AN-1301, AN-1301-G, AN-2801 & AN-2801-B

REV. DATE

12-18-08

MATERIAL: ALUMINUM ALLOY #ADC-12

FINISH: NATURAL (NO SUFFIX)

GRAY (SUFFIX -G)

SMOOTH BLACK (SUFFIX -B)

NOTES:

- 1) FOUR (4) M4 x 20mm (0.787") LG. SCREWS SUPPLIED FOR ASSEMBLY OF COVER TO BODY.
- 2) ALL HOLE DIAMETERS HAVE ±0.005 TOLERANCE ALL OTHER DIMENSIONS HAVE ±0.015 TOLERANCE

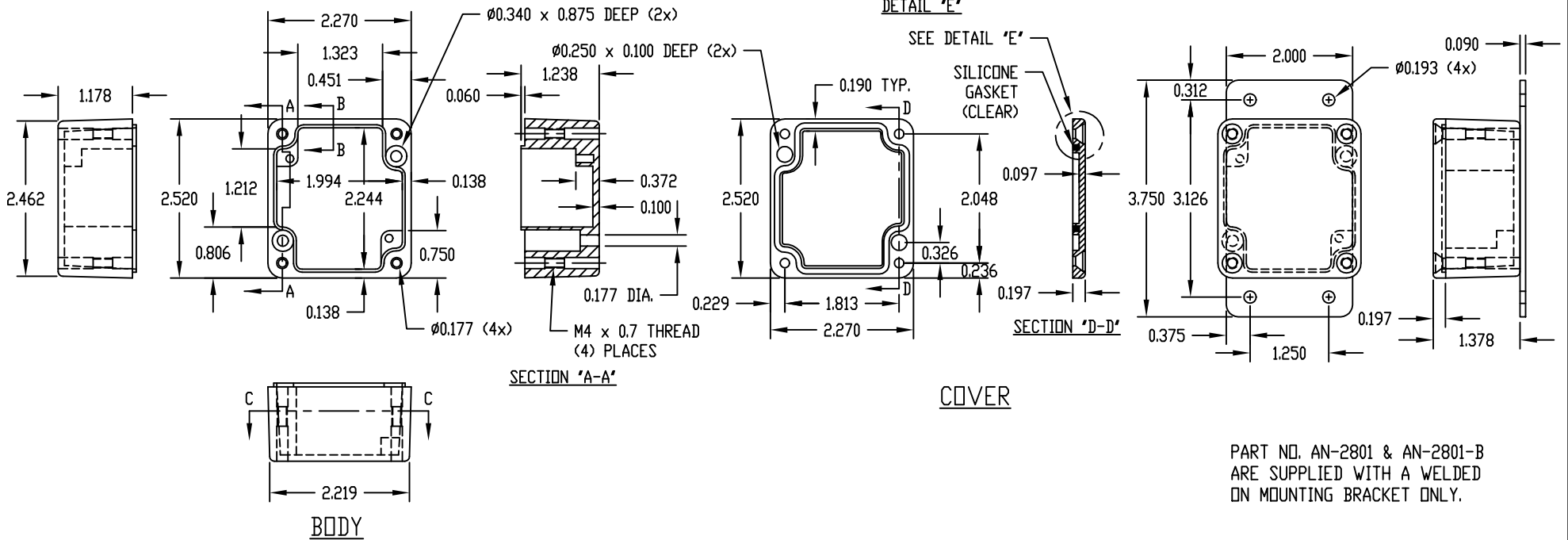
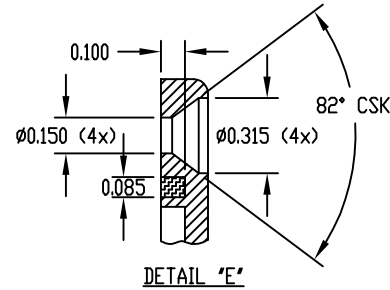
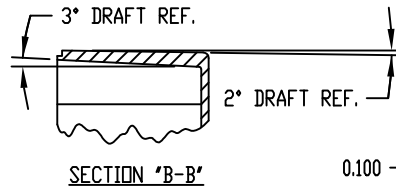
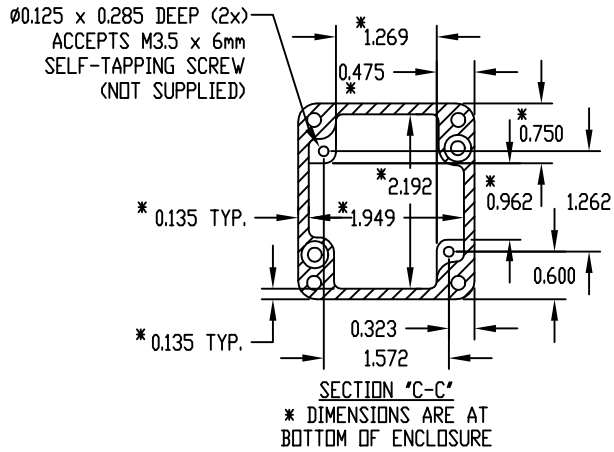

PART NO. AN-2801 & AN-2801-B ARE SUPPLIED WITH A WELDED ON MOUNTING BRACKET ONLY.