

## FEATURES

- Highest Efficiency Solution Up to 12W
- High Power Factor
- Low Total Harmonic Distortion
- Low Component Count
- Low EMI
- Low Crest Factor
- Low Flicker Index
- Low Strobe Light Motion Effect
- Electrolytic Capacitor is not necessary
- No Magnetic Component
- Over Temperature Protection
- Over Current Protection
- Brightness Stability over AC Line Voltage Variation
- Space-Saving, Thermally-Enhanced SOP-16 EP (Exposed Pad) Package
- ACT811/B for 100-120VAC Application

## APPLICATIONS

- Solid State Lighting (SSL)
- LED Tubes, Downlights and Bulbs
- Replacement of Lamps for 100-120VAC

## GENERAL DESCRIPTION

The ACT811/B is LED driver IC based on Active-Semi's Patented Active Direct Drive™ Technology and Patent-Pending Active Valley Fill™ that adaptively drives a string of variable-weighted LED segments up to 12W directly from an AC line voltage with very few total components. By adaptively modulating the variable-segment-weighted LED string voltage to match the varying AC line voltage, the Active Direct Drive™ Technology results in the ACT811/B having highest efficiency, high power factor, and low total harmonic distortion. The high efficiency and high performance make the ACT811/B ideal for advanced energy saving solid state lighting applications and eases thermal design.

With very few external components, the ACT811/B ensures high reliability and long life time for LED-based luminaire designs. In addition, the IC protects the LEDs from over current, and over temperature conditions. The ACT811/B are optimized to operate at 100-120VAC and non-dimmable application up to 12W.

The ACT811/B also incorporate Active-Semi's Patent-Pending Active Valley Fill™ Technology for maintaining smooth light output for the full AC cycle, enabling the LEDs to operate without noticeable flicker or strobe light motion effects. These devices drive the LED string without high frequency switching.

The ACT811/B are available in the SOP-16EP package.

## TYPICAL APPLICATION DIAGRAM

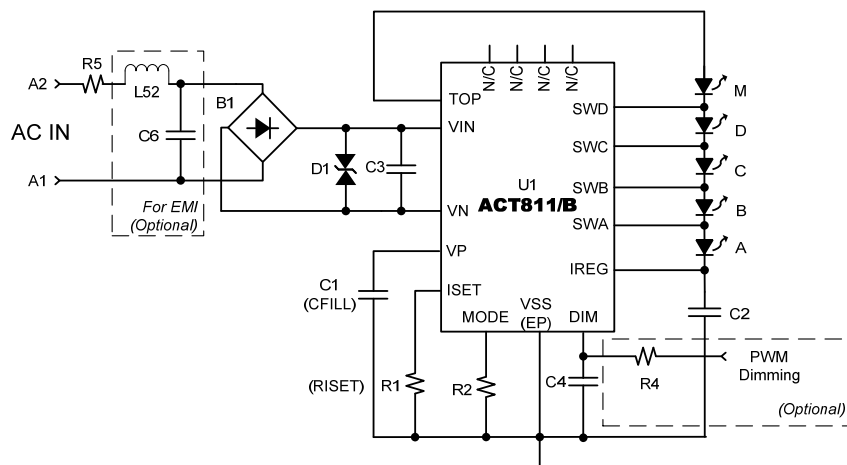

## TABLE OF CONTENTS

General Information .....	p. 01
Functional Block Diagram .....	p. 03
Ordering Information .....	p. 04
Pin Configuration .....	p. 04
Pin Descriptions .....	p. 05
Absolute Maximum Ratings .....	p. 06
Electrical Characteristics .....	p. 07
Typical Performance Characteristics .....	p. 09
Functional Description .....	p. 13
Active Direct Drive <sup>™</sup> Controller .....	p. 13
Start-Up .....	p. 13
Normal Operation .....	p. 13
Active Valley Fill <sup>™</sup> .....	p. 13
LED Arrangement .....	p. 14
PWM and 0-10V Dimming .....	p. 14
Protection .....	p. 14
SOP-16 EP (EXPOSED PADDLE) Package Outline and Dimensions .....	p. 15

FUNCTIONAL BLOCK DIAGRAM

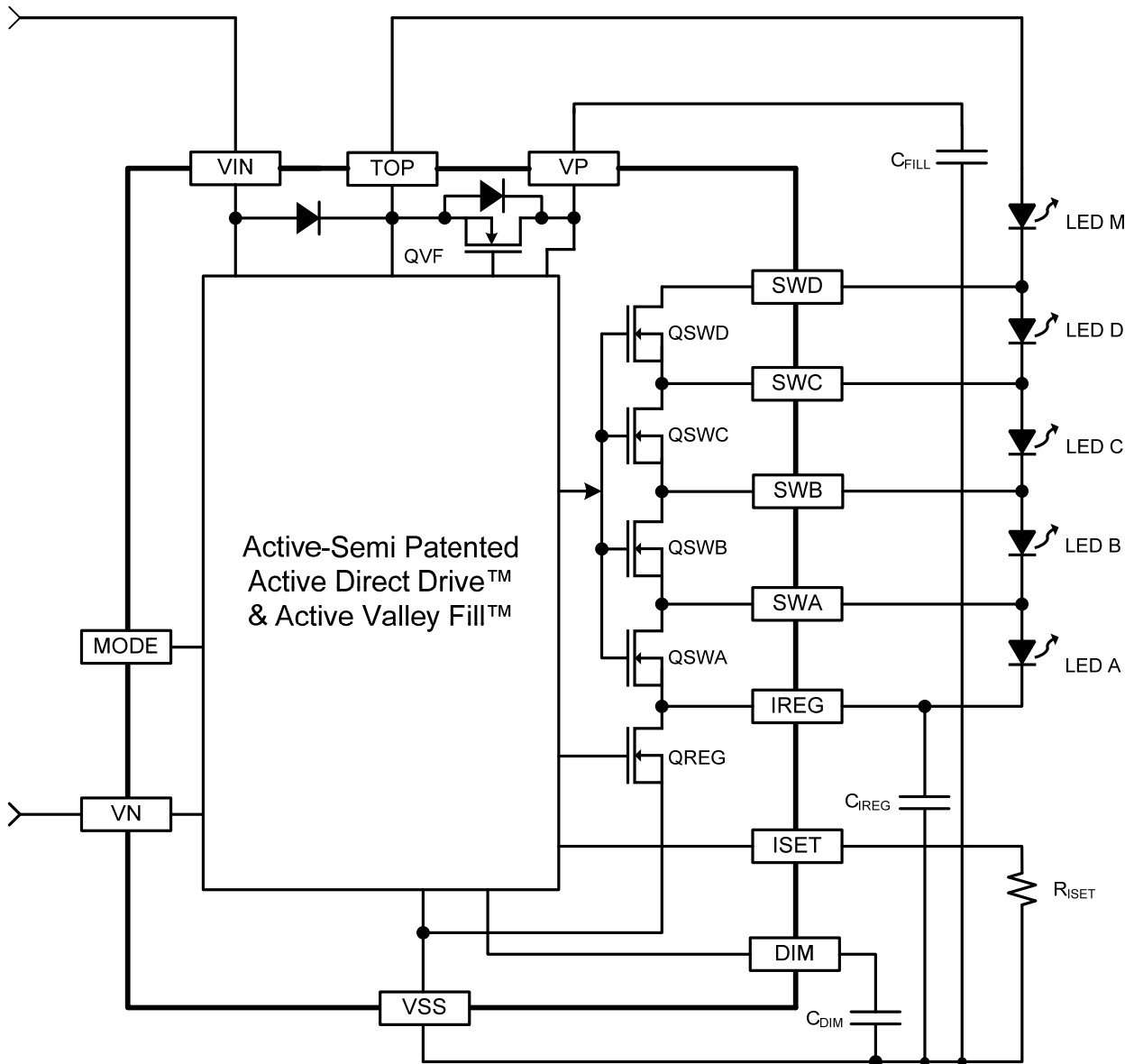

## ORDERING INFORMATION<sup>①②</sup>

PART NUMBER	TEMPERATURE RANGE	PACKAGE	PINS	PACKING METHOD
ACT811YK-T	-40°C to 125°C	SOP-16EP	16	TAPE & REEL
ACT811BYK-T	-40°C to 125°C	SOP-16EP	16	TAPE & REEL

①: All Active-Semi components are RoHS Compliant and with Pb-free plating unless specified differently. The term Pb-free means semiconductor products that are in compliance with current RoHS (Restriction of Hazardous Substances) standards.

②: Standard product options are identified in this table. Contact factory for custom options.

## PIN CONFIGURATION

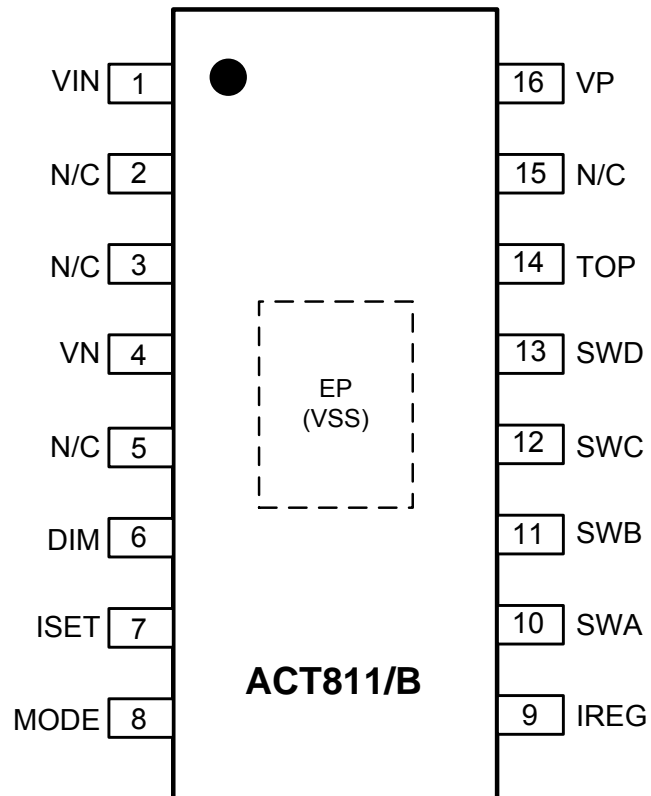

TOP VIEW  
SOP-16EP

## PIN DESCRIPTIONS

PIN	NAME	DESCRIPTION
1	VIN	Positive rectified AC Voltage. Connect to the positive output of the full bridge rectifier.
2	N/C	Not Connected.
3	N/C	Not Connected.
4	VN	Negative rectified AC Voltage. Connect to the negative output of the full bridge rectifier.
5	N/C	Not Connected.
6	DIM	Dimming Control Pin. To dim the LED power, drive the DIM voltage from 0 to 2.35V. Without dimming control, connect a bypass capacitor 1uF to VSS. See more information in Dimming Section.
7	ISET	Current Setting. Connect a resistor RISET between ISET and VSS to determine the LED current.
8	MODE	Mode selection of LED arrangement. As for LED string A-B-C-D-TOP(M), MODE = VSS to select 3-6-6-18-TOP(M), or MODE = Floating for 2-4-8-16-TOP(M). See more information in LED Arrangement Section.
9	IREG	Current Regulation Output. Connect to the bottom of LED string.
10	SWA	LED Switch A.
11	SWB	LED Switch B.
12	SWC	LED Switch C.
13	SWD	LED Switch D.
14	TOP	LED String Top. Connect to the top of LED string.
15	N/C	Not Connected.
16	VP	Positive Supply Voltage. Connect a capacitor CFILL with appropriate voltage rating between VP pin and VSS pin.
EP	VSS	Ground. Exposed Pad shown as dashed block. The exposed ground pad must be electrically connected to Ground.

## ABSOLUTE MAXIMUM RATINGS<sup>①</sup>

PARAMETER	VALUE	UNIT
VIN, VP, TOP to VSS	-0.3 to 200	V
TOP to SWD	-0.3 to 70	V
SWD to SWC	-0.3 to 70	V
SWC to SWB	-0.3 to 32	V
SWB to SWA	-0.3 to 25	V
SWA to IREG	-0.3 to 15	V
IREG to VSS	-0.3 to 25	V
ISET, MODE, DIM to VSS	-0.3 to 5	V
VN to VSS	-200 to 0.3	V
Maximum Power Dissipation (T <sub>A</sub> = 85°C)	1.5	W
Thermal Resistance (θ <sub>JC</sub> )	40	°C/W
Storage temperature range	-65 to 150	°C
Junction temperature range	-40 to 150	°C
Lead temperature (soldering, 10 seconds)	300	°C
ESD, Human Body Model, ESDA/JEDEC JDS-001-2012	2 1.6 (pin 6)	KV
ESD, Machine Model, JEDEC EIA/JESD22-A115	250 100 (pin 6)	V

①: Do not exceed these limits to prevent damage to the device. Exposure to absolute maximum rating conditions for long periods may affect device reliability.

## ELECTRICAL CHARACTERISTICS

 (T<sub>A</sub> = 25°C unless otherwise specified)

PARAMETER	SYMBOL	TEST CONDITIONS	MIN	TYP	MAX	UNIT	
<b>Input Supply</b>							
Operating Voltage Range	V <sub>OP</sub>		90		135	V <sub>AC</sub>	
Under Voltage Lockout (UVLO) Threshold	V <sub>UVLO</sub>	VP Rising, Hysteresis = 2.0V		22		V	
Supply Current	I <sub>VP</sub>	V <sub>VP</sub> = 100V		400	1700	μA	
<b>Controller</b>							
Lamp Power	P <sub>LAMP</sub>			12		W	
ISET Voltage	V <sub>ISET</sub>	R <sub>ISET</sub> =91KΩ		2.35		V	
ISET Current	I <sub>ISET</sub>	R <sub>ISET</sub> =91KΩ		26		μA	
Current Setting Ratio	K <sub>ISET</sub>	ACT811, CNT=0000		5550		A/A	
		ACT811B, CNT=0000		2900		A/A	
IREG Current	I <sub>IREG</sub>	R <sub>ISET</sub> =91KΩ, CNT=0000	ACT811	130	140	150	mA
			ACT811B	69	75	81	mA
		R <sub>ISET</sub> =91KΩ, CNT=1111	ACT811		75		mA
			ACT811B		140		mA
IREG Discharge Current Ratio	K <sub>DCHG</sub>	R <sub>ISET</sub> =91KΩ		0.8		A/A	
IREG Clamp Threshold	V <sub>CLIREG</sub>	CNT=1111		15		V	
LED Tracking Rising Threshold	V <sub>TRACKR</sub>	ACT811, CNT=0000, R <sub>ISET</sub> =91KΩ	MODE=VSS		10.8		V
			MODE=N/C		7.5		V
		ACT811B, CNT=0000, R <sub>ISET</sub> =91KΩ	MODE=VSS		10.6		V
			MODE=N/C		7.1		V
LED Tracking Falling Threshold	V <sub>TRACKF</sub>			1		V	
LED Switch Tracking Delay	T <sub>TRK</sub>			80		μs	

## ELECTRICAL CHARACTERISTICS CONT'D

 (T<sub>A</sub> = 25°C unless otherwise specified)

PARAMETER	SYMBOL	TEST CONDITIONS	MIN	TYP	MAX	UNIT
<b>LED Switches</b>						
LED Switch On Resistance	R <sub>QSWA</sub>	QSWA, I <sub>SWA</sub> = 30mA		3	5	Ω
	R <sub>QSWB</sub>	QSWB, I <sub>SWB</sub> = 30mA		5	10	
	R <sub>QSWC</sub>	QSWC, I <sub>SWC</sub> = 30mA		10	20	
	R <sub>QSWD</sub>	QSWD, I <sub>SWD</sub> = 30mA		10	20	
LED Switch Leakage Current	I <sub>LKG</sub>	QSWA, QSWB, QSWC, QSWD, V <sub>DS</sub> = Abs Max			10	μA
<b>Protections</b>						
Thermal Regulation Threshold	T <sub>FB</sub>		135	155		°C
VN Switch On Resistance	R <sub>QVN</sub>	I <sub>VN</sub> = 10mA		25	50	Ω
VN Current Limit	I <sub>VNMAX</sub>	ACT811, CNT=0000 ACT811B, CNT=0000		280 170		mA
IREG High Detection Voltage	V <sub>IREGHI</sub>			23		V
VN Start-Up Current	I <sub>VNSU</sub>	V <sub>VN</sub> = -150V		2		mA
<b>Valley Fill</b>						
Stop-Discharge Threshold	V <sub>STDCHG</sub>	V <sub>in</sub> Rising		80		V

## TYPICAL PERFORMANCE CHARACTERISTICS

( $T_A = 25^\circ\text{C}$ ,  $V_{IN} = 120\text{VAC}$ , unless otherwise specified.)

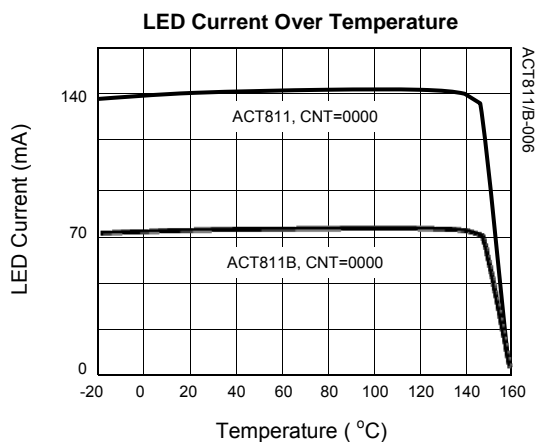
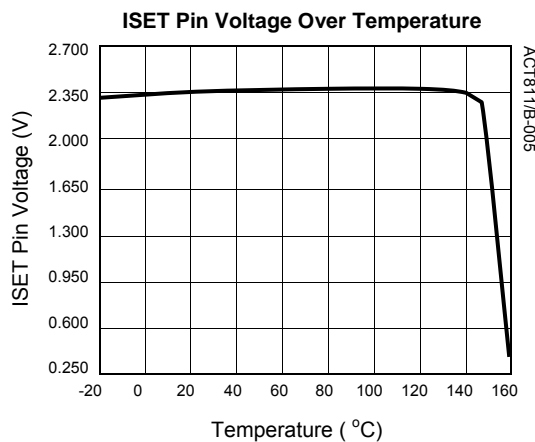
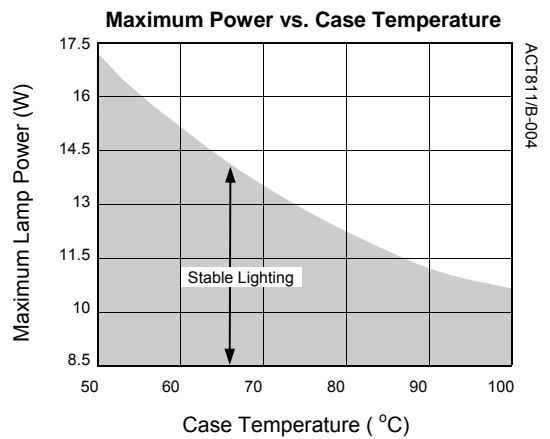
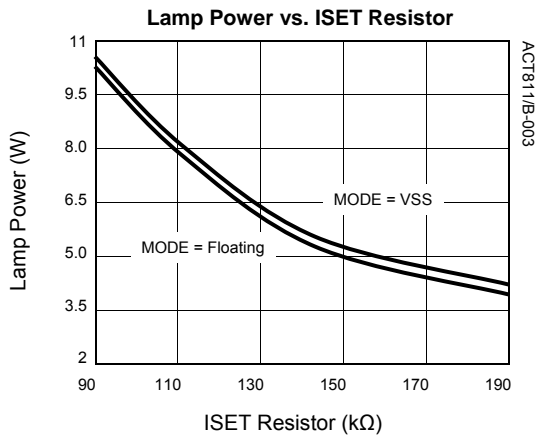
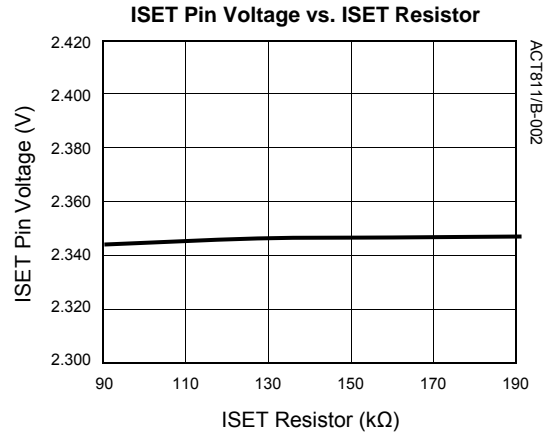
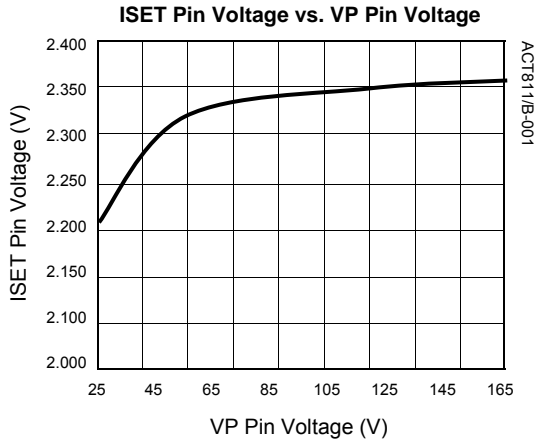

**TYPICAL PERFORMANCE CHARACTERISTICS CONT'D**

( $T_A = 25^\circ\text{C}$ ,  $V_{IN} = 120\text{VAC}$ , unless otherwise specified.)

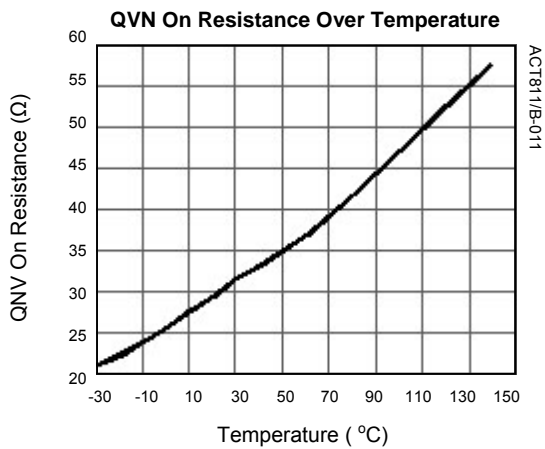
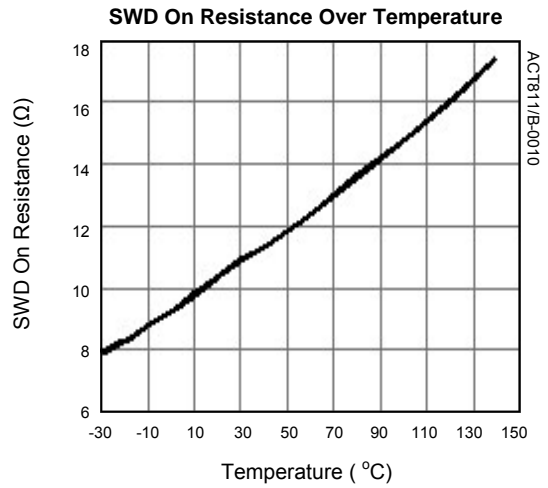
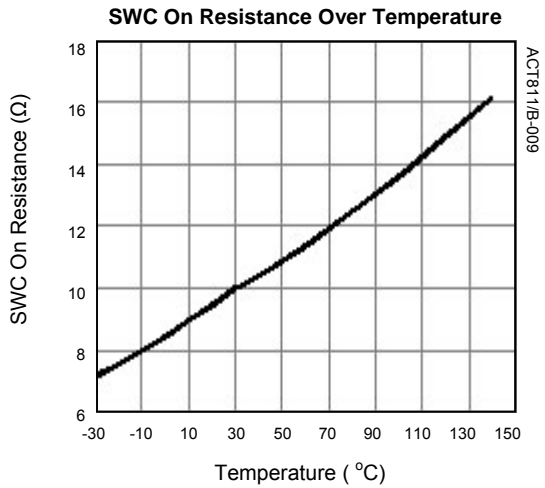
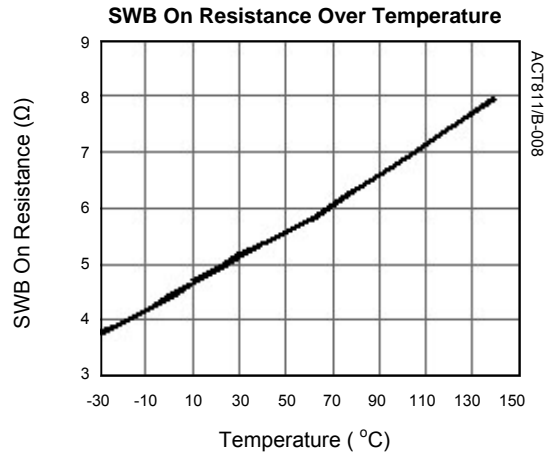
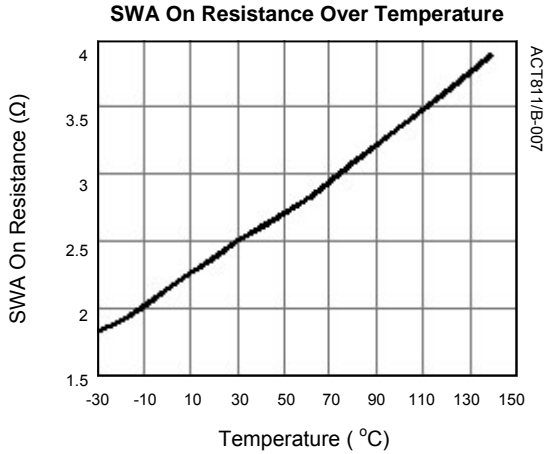

## TYPICAL PERFORMANCE CHARACTERISTICS CONT'D

( $T_A = 25^\circ\text{C}$ ,  $V_{IN} = 120\text{VAC}$ , unless otherwise specified.)

**TOP and VP Waveforms, ACT811**

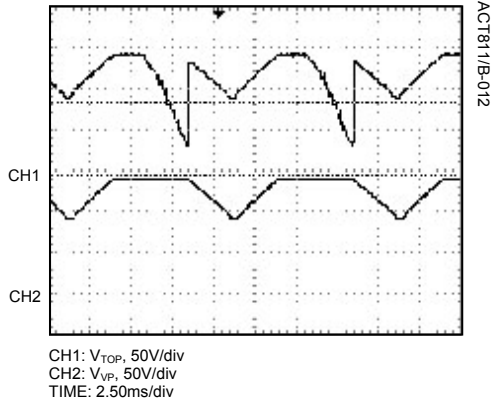

**TOP and VP Waveforms, ACT811B**

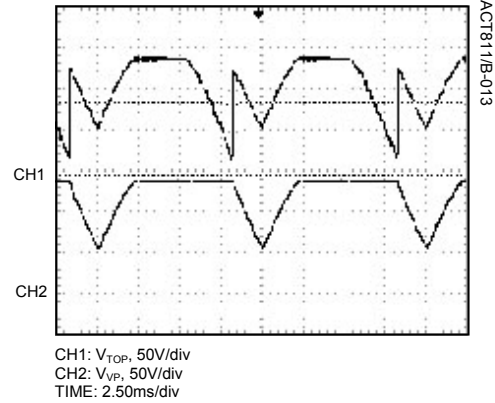

**TOP and IREG Waveforms, ACT811**

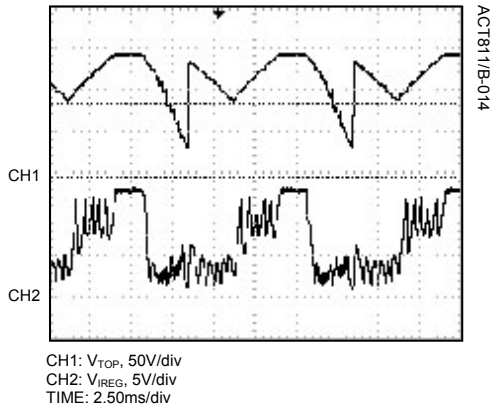

**TOP and IREG Waveforms, ACT811B**

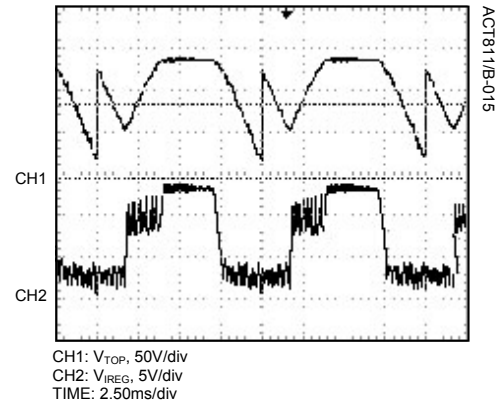

**VIN V and TOP I Waveforms, ACT811**

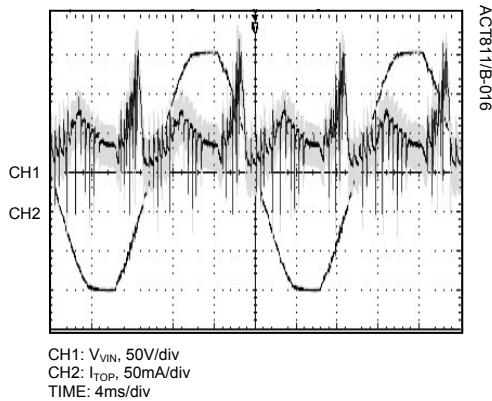

**VIN V and TOP I Waveforms, ACT811B**

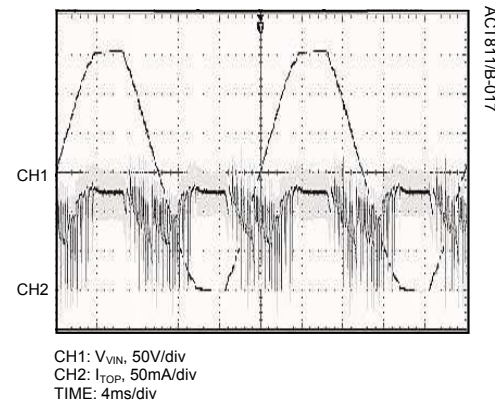

## TYPICAL PERFORMANCE CHARACTERISTICS CONT'D

( $T_A = 25^\circ\text{C}$ ,  $V_{IN} = 120\text{VAC}$ , unless otherwise specified.)

**VIN V and I Waveforms, ACT811**

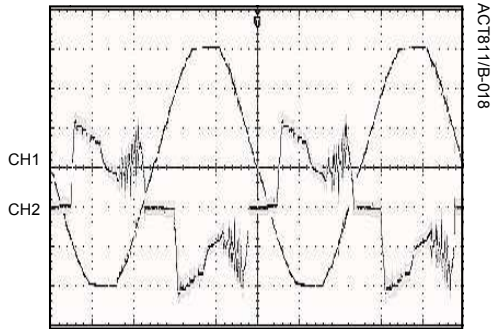

CH1:  $V_{VIN}$ , 50V/div  
CH2:  $I_{VIN}$ , 100mA/div  
TIME: 4ms/div

**VIN V and I Waveforms, ACT811B**

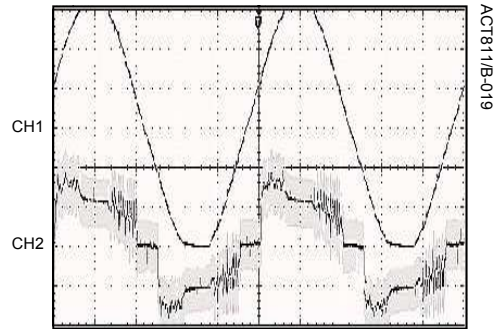

CH1:  $V_{VIN}$ , 50V/div  
CH2:  $I_{VIN}$ , 100mA/div  
TIME: 4ms/div

**TOP V and I Waveforms, ACT811**

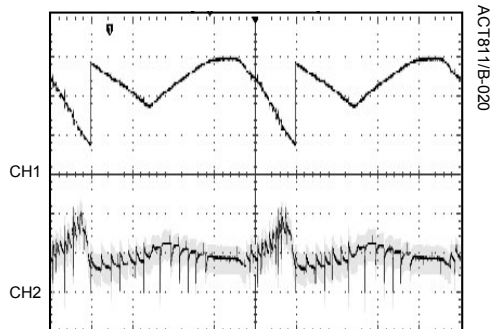

CH1:  $V_{TOP}$ , 50V/div  
CH2:  $I_{TOP}$ , 100mA/div  
TIME: 2ms/div

**TOP V and I Waveforms, ACT811B**

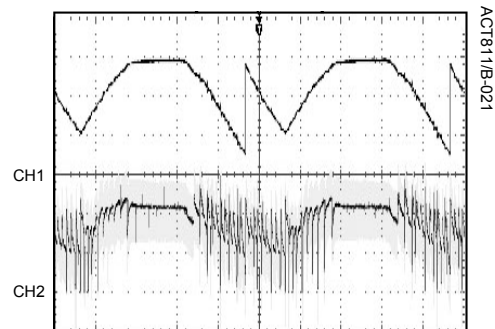

CH1:  $V_{TOP}$ , 50V/div  
CH2:  $I_{TOP}$ , 50mA/div  
TIME: 2ms/div

## FUNCTIONAL DESCRIPTION

### Active Direct Drive<sup>™</sup> Controller

The ACT811/B utilizes Active-Semi's Patented Active Direct Drive<sup>™</sup> and Active Valley Fill<sup>™</sup> Technologies that adaptively drives a string of LEDs up to 12W directly from an AC line voltage. As the instantaneous AC line voltage varies, the ACT811/B adaptively adjusts the number of active LEDs in a variable-weighted LED string to track the instantaneous rectified line voltage. The result is a very simple driver circuit with high power transfer and minimal power loss.

As shown in the *Typical Application Circuit*, the ACT811/B application circuit comprises a full-wave bridge diode, with the positive output of the rectified line voltage going to the VIN pin of the ACT811/B, while the negative output of the rectified line voltage going to the VN pin. The string of LEDs is divided into 5 groups, named LED groups A, B, C, D, and M. The top of LED groups A, B, C, and D are each connected to the SWA, SWB, SWC, and SWD pins, respectively. The top of LED group M is connected to the positive output of rectified line voltage via a anti-reverse protection diode. In addition, a valley fill capacitor CFILL is connected between the VP pin and VSS pin, while the current setting resistor R<sub>ISET</sub> is connected between ISET and VSS.

Within the IC, an Active-Semi's Patented Active Direct Drive<sup>™</sup> Controller generates a signal to control a sequential string of LED switches QSWA, QSWB, QSWC, and QSWD for driving SWA, SWB, SWC, and SWD pins, respectively. Each of these LED switches is either On or Off, thereby shorting out or leaving the corresponding LED group active in the current path. By appropriately determining which LED groups to be active and which LED groups to be shorted out, the Controller ensures that the total number of active LEDs track the instantaneous rectified line voltage. The LED current is regulated and set by the external R<sub>ISET</sub> resistor. In addition, a QVF switch connects the TOP terminal to VP terminal when discharging the valley fill capacitor.

The Current Regulator controls the gate of the QREG switch so that the current through QREG is inversely proportional at ACT811 or proportional at ACT811B to the number of active LEDs in the string. The number of active LEDs track optimally to the rectified line voltage. Furthermore, since the LED current is inversely proportional to the number of active LEDs, the instantaneous LED power is approximately constant for most of the Normal region operation at ACT811; Regarding ACT811B, since the current is proportional, it gains PF >0.95

and THD <30%. In the event that the LED tracking algorithm fails, the IC goes into the Protection Mode.

### Start-Up

When power is first applied, the IC is in the Disabled state. The Internal Supply block starts to charge the CFILL. When the VP voltage is higher than the Under Voltage Lockout Threshold, the IC enters the Normal state.

### Normal Operation

Average IREG current (LED current) is set by ISET resistor by following equations:

$$I_{SET} = V_{ISET} / R_{ISET}$$

$$IREG \text{ Current} = K_{ISET} \cdot I_{SET}$$

The Controller detects the gap between the voltage of IREG and ground, and compares against the LED Tracking Rising / Falling Threshold. If the gap voltage is higher than LED Tracking Rising Threshold and the line voltage is rising, the controller increases the number of active LEDs. If gap voltage is less than LED Tracking Falling Threshold and the line voltage is decreasing, the controller decreases the number of active LEDs. By following this proprietary algorithm, the number of active LEDs optimally track the rectified line voltage while ensuring that the gap voltage is between Tracking Rising Threshold and Tracking Falling Threshold. In the event that LED tracking algorithm fails to maintain the IREG lower than LED Fault Detection Threshold, the IC goes into the Protection state.

### Active Valley Fill<sup>™</sup>

The Patent-Pending Valley Fill operations works as follows. The Valley Fill Block controls 2 states in a line cycle, Normal and Discharge states. When VIN is increasing in Normal states, the CFILL capacitor is charged through the forward-biased QVF body diode junction. The charging continues until VP reaches its peak value.

As VIN decreases, the Valley Fill Block remains in Normal states until the number active LEDs is minimum, upon which the Valley Fill block enters the Discharge state. In the Discharge state, CFILL

---

## FUNCTIONAL DESCRIPTION

discharges to supply power to all LED groups A, B, C, D and M. LED current is reduced to 80% in discharge state.

### LED Arrangement

For optimal efficiency with simple driving mechanism, the ACT811/B follows Active-Semi's Patented Direct Drive variable segmentation of the LED string. The total number of LEDs in the string is set to track the peak of the rectified line voltage, while the IC switches control the LEDs in a variable-weighted manner, with LED group A being the lowest weight and LED group D being the largest weight.

LED Arrangement is programmed by using MODE pin. Respectively, A, B, C and D groups have 2, 4, 8 and 16 LEDs when MODE is floating, and 3, 6, 6, 18 LED when MODE is tied to VSS.

The group M number of LEDs is chosen to complement to the peak of the rectified line voltage in addition to group A, B, C and D for 100-120VAC.

### PWM and 0-10V Dimming

The PWM or 0-10V dimming signal goes through a filter to control the DIM at range of 0V - 2.35V to adjust the LED current. The DIM pin is required to connect a bypass capacitor 1uF to VSS.

For PWM signal dimming, a resistor is connected to the DIM coupling with the bypass capacitor as a lowpass filter. When the PWM control signal inputs, it's filtered to the range of 0V - 2.35V.

For 0-10V analog dimming, a voltage divider network is applied to turn into 0V - 2.35V range to control the LED current.

### Protection

The ACT811/B incorporates multiple levels of protection to ensure ruggedness in operation. These include:

1. Hot Plug Protection: When hot plugging, there is spike voltage at VIN to VN much higher than normal operation. If the voltage at IREG is higher than IREG High Detection Voltage ( $V_{IREGHI}$ ), the circuit is protected in this short period until entering normal operation.
2. Over Temperature Protection: When IC junction temperature is higher than the Thermal Regulation Threshold ( $T_{FB}$ ), the current is

reduced linearly according to the temperature increment, and the luminous output is regulated stably without blinking.

3. Input Current Limit: The maximum current is limited under the VN Current Limit ( $I_{VNMAX}$ ) to protect the IC and system.

## SOP-16 EP (EXPOSED PADDLE) PACKAGE OUTLINE AND DIMENSIONS

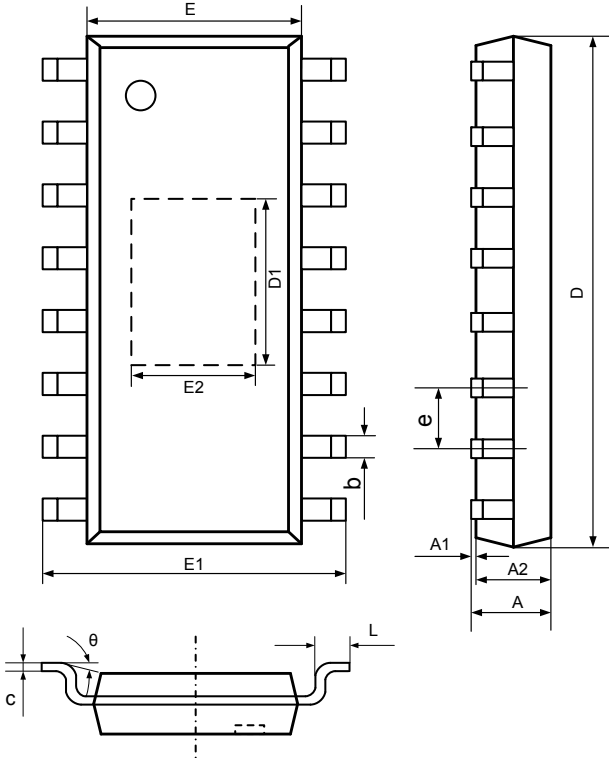

SYMBOL	DIMENSION IN MILLIMETERS		DIMENSION IN INCHES	
	MIN	MAX	MIN	MAX
A	1.350	1.700	0.053	0.067
A1	0.020	0.120	0.001	0.005
A2	1.350	1.550	0.053	0.061
b	0.380	0.470	0.015	0.019
c	0.200	0.250	0.008	0.010
D	9.860	10.06	0.388	0.396
D1	3.300	4.000	0.130	0.157
E	3.800	4.000	0.150	0.157
E1	5.800	6.200	0.228	0.244
E2	1.780	2.500	0.070	0.098
e	1.270 TYP		0.050 TYP	
L	0.450	0.800	0.018	0.031
θ	0°	8°	0°	8°

Active-Semi, Inc. reserves the right to modify the circuitry or specifications without notice. Users should evaluate each product to make sure that it is suitable for their applications. Active-Semi products are not intended or authorized for use as critical components in life-support devices or systems. Active-Semi, Inc. does not assume any liability arising out of the use of any product or circuit described in this datasheet, nor does it convey any patent license.

Active-Semi and its logo are trademarks of Active-Semi, Inc. For more information on this and other products, contact [sales@active-semi.com](mailto:sales@active-semi.com) or visit <http://www.active-semi.com>.

 is a registered trademark of Active-Semi.