

ActiveQRTM Quasi-Resonant PWM Controller

FEATURES

- Quasi-Resonant Operation
- Adjustable up to 150kHz Switching Frequency
- Accurate OCP/OLP Protection
- Integrated Patented Frequency Foldback Technique
- Integrated Patented Line and Primary Inductance Compensation
- Built-in Soft-Start Circuit
- Line Under-Voltage, Thermal, Output Over-voltage, Output Short Protections
- Current Sense Resistor Short Protection
- Transformer Winding Short Protection
- 100mW Standby Power
- Complies with Global Energy Efficiency and CEC Average Efficiency Standards
- Tiny SOT23-6 Packages

APPLICATIONS

- AC/DC Adaptors/Chargers for Cell Phones, Cordless Phone, PDAs, E-books
- Adaptors for Portable Media Player, DSCs, Set-top boxes, DVD players, records
- Linear Adapter Replacements

GENERAL DESCRIPTION

The ACT510 is a high performance peak current mode PWM controller. ACT510 applies *ActiveQRTM* and frequency foldback technique to reduce EMI and improve efficiency. ACT510's maximum switching frequency is set at 150kHz. Very low standby power, good dynamic response and accurate voltage regulation is achieved with an opto-coupler and the secondary side control circuit.

The burst mode operation enables low standby power of 100mW with small output voltage ripple. By applying frequency foldback and *ActiveQRTM* technology, ACT510 increases the average system efficiency compared to conventional solutions and

exceeds the latest ES2.0 efficiency standard with good margin.

ACT510 integrates comprehensive protection. In case of over temperature, over voltage, winding short, current sense resistor short, open loop and overload conditions, it would enter into auto restart mode including Cycle-by-Cycle current limiting.

ACT510 is to achieve no overshoot and very short rise time even with a big capacitive load (4000 μ F) with the built-in fast and soft start process.

The Quasi-Resonant (QR) operation mode can improve efficiency, reduce EMI and further reduce the components in input filter.

ACT510 is ideal for applications up to 60 Watts.

Figure 1:
Simplified Application Circuit

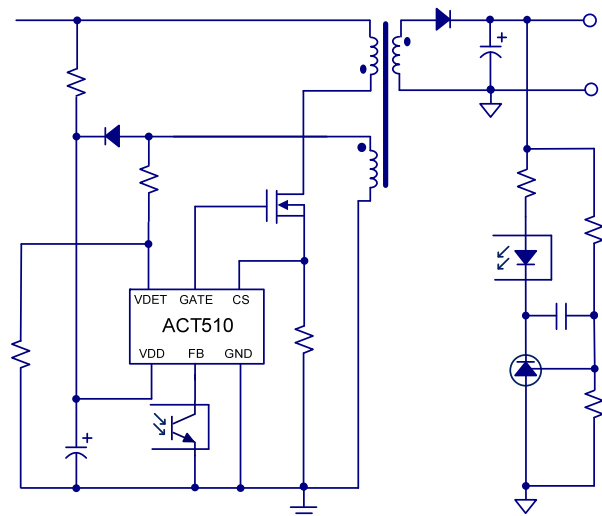

ORDERING INFORMATION

PART NUMBER	TEMPERATURE RANGE	PACKAGE	PINS	PACKING METHOD	TOP MARK
ACT510US-T	-40°C to 85°C	SOT23-6	6	TUBE & REEL	FSET

PIN CONFIGURATION

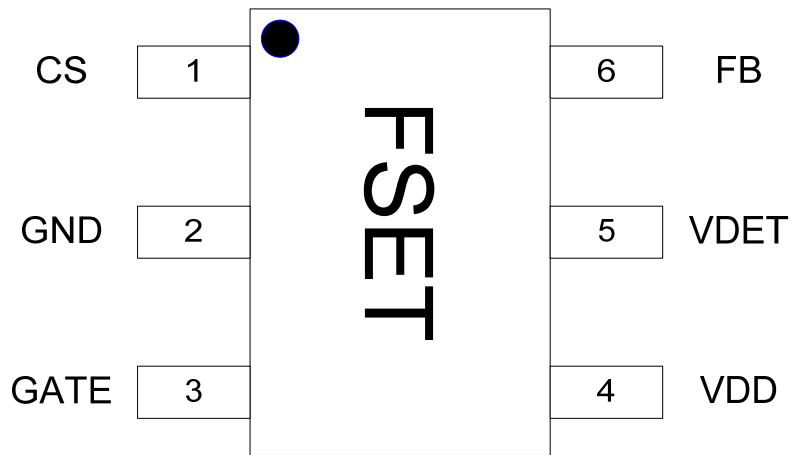

SOT23-6
ACT510US

PIN DESCRIPTIONS

PIN	NAME	DESCRIPTION
1	CS	Current Sense Pin. Connect an external resistor (R_{CS}) between this pin and ground to set peak current limit for the primary switch.
2	GND	Ground.
3	GATE	Gate Drive. Gate driver for the external MOSFET transistor.
4	VDD	Power Supply. This pin provides bias power for the IC during startup and steady state operation.
5	VDET	Valley Detector Pin. Connect this pin to a resistor divider network from the auxiliary winding to detect zero-crossing points for valley turn on operation.
6	FB	Feedback Pin. Connect this pin to optocouplers's collector for output regulation.

Figure 4:
Universal VAC Input, 5V/2A Output Charger

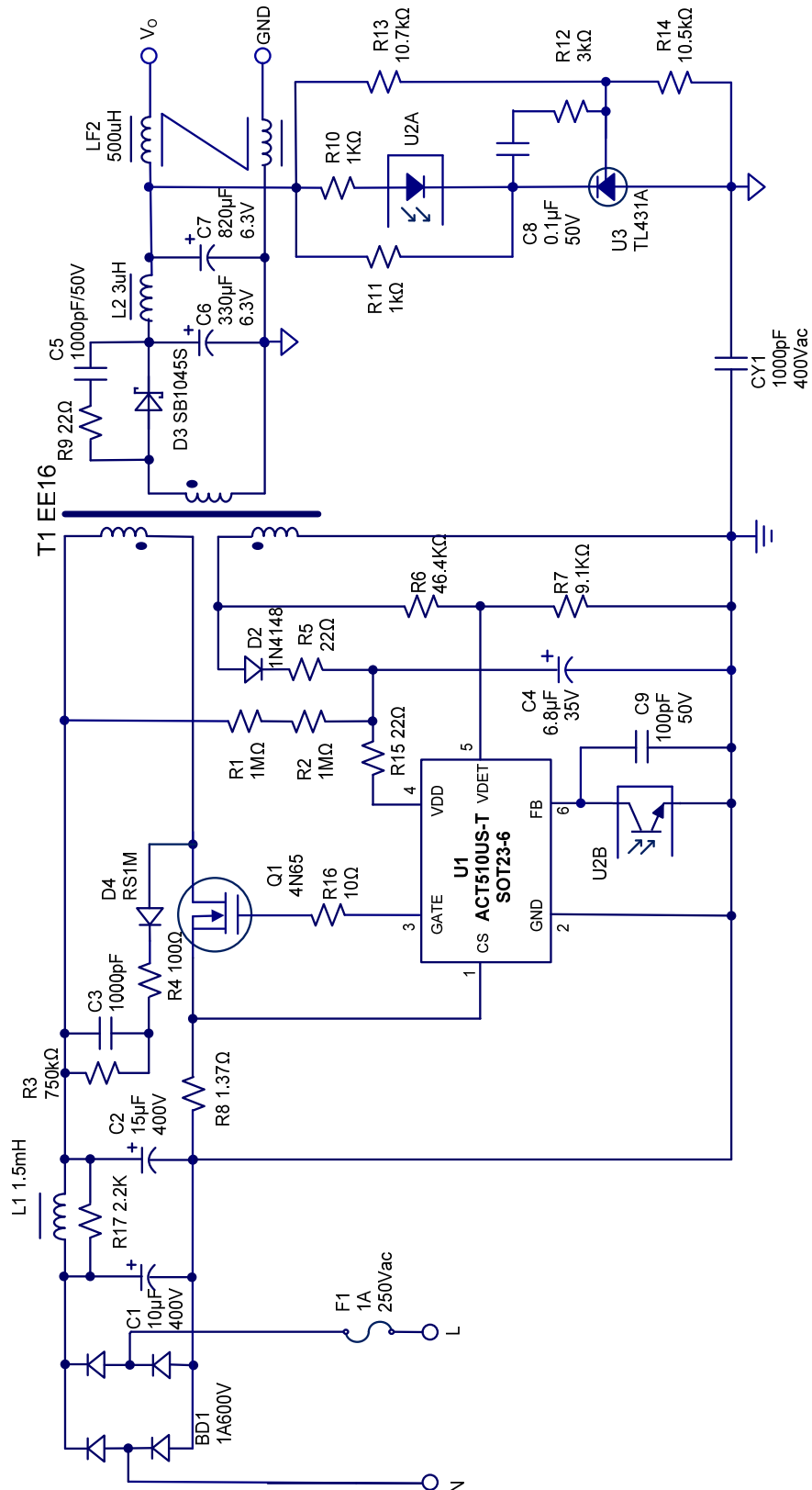

Table 1:
ACT510 5V10W Bill of Materials

ITEM	REFERENCE	DESCRIPTION	QTY	MANUFACTURER
1	U1	IC, ACT510, SOT23-6	1	Active-Semi
2	C1	Capacitor, Electrolytic, 15µF/400V, 12x16mm	1	RUBYCON
3	C2	Capacitor, Electrolytic, 10µF/400V, 10x15mm	1	RUBYCON
4	C3	Capacitor, Ceramic, 1000pF/500V, 0805,SMD	1	POE
5	C4	Capacitor, Electrolytic, 6.8µF/35V, 5x11mm	1	POE
6	C5	Capacitor, Ceramic, 1000PF/100V, 0805,SMD	1	POE
7	C6	Capacitor, Electrolytic, 330µF/6.3V, 6.3x8mm	1	KSC
8	C7	Capacitor, Electrolytic, 820µF/6.3V, 6.5x15mm	1	KSC
9	C8	Capacitor, Ceramic, 0.1µF/25V, 0805, SMD	1	POE
10	C9	Capacitor, Ceramic, 1000pF/25V, 0805, SMD	1	POE
11	CY1	Safety Y1, Capacitor, 1000pF/400V, Dip	1	UXT
12	BD1	Bridge Rectifier, D1010S, 1000V/1.0A, SDIP	1	PANJIT
13	D2	Fast Recovery Rectifier, RS1G, 200V/1.0A, RMA	1	PANJIT
14	D3	Diode, Schottky, 45V/10A, S10U45S, SMD	1	Diodes
15	D4	Fast Recovery Rectifier, RS1M, 1000V/1.0A, RMA	1	PANJIT
16	D5	Diode,Ultra Fast, LL4148, SMD Open	1	Good-Ark
17	L1	Axial Inductor, 1.5mH, 5*7, Dip	1	SoKa
18	L2	Axial Inductor, 0.55*5T, 5*7, Dip	1	SoKa
19	LF2	CM Filter,R6K, 500µH, 0.55*2 6T	1	SoKa
20	Q1	Mosfet Transistor, 4N60, TO-262	1	Infineon
21	PCB1	PCB, L*W*T=53x29x1.6mm, Cem-1, Rev:A	1	Jintong
22	F1	Fuse, 1A/250V	1	TY-OHM
23	R1,R2	Chip Resistor, 1.0MΩ 1206, 5%	2	TY-OHM
24	R3	Carbon Resistor, 750KΩ, 0805, 5%	1	TY-OHM
25	R4	Chip Resistor, 100Ω, 0805, 5%	1	TY-OHM
26	R5, R9, R15	Chip Resistor, 22Ω, 0805, 5%	3	TY-OHM
27	R6	Chip Resistor, 46.4KΩ, 0805,1%	1	TY-OHM
28	R7	Chip Resistor, 9.1KΩ, 0805, 1%	1	TY-OHM
29	R8	Chip Resistor, 1.37Ω, 1206 , 5%	1	TY-OHM
30	R10, R11	Chip Resistor, 1KΩ, 0805, 5%	2	TY-OHM
31	R12	Chip Resistor, 3KΩ, 0805, 5%	1	TY-OHM
32	R13	Chip Resistor, 10.7KΩ, 0805, 1%	1	TY-OHM
33	R14	Chip Resistor, 10.5KΩ, 0805, 1%	1	TY-OHM
34	R16	Chip Resistor, 10Ω, 0805, 5%	1	TY-OHM
35	R17	Chip Resistor, 2.2KΩ, 0805, 5%	1	TY-OHM
36	T1	Transformer, Lp=0.54mH, EE16	1	
37	U2	OPOT PC817C	1	Sharp
38	IC3	TL431 TO-92	1	ST