



# QUARTECH

## The Next Generation Module

### CS6V-215 | 220M

#### PRODUCT | KEY BENEFITS

##### Higher Energy Yield



- Outstanding performance at low irradiance
- Maximum energy yield at low NOCT
- Improved energy production through reduced cell series resistance

##### Increased System Reliability



- Enhanced system performance stability with PID resistant technology
- Long term system reliability with IP67 junction box
- Enhanced system reliability in extreme temperature environment with special cell level stress release technology

##### Extra Value to Customers



- Positive power tolerance up to 5W
- Stronger 40mm robust frame to hold 5400 Pa load
- Anti-glare project evaluation
- 25 year linear performance warranty
- 25 year performance warranty insurance

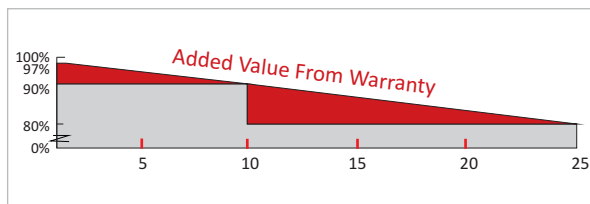

#### QUARTECH MODULE | THE NEXT GENERATION MODULE

Canadian Solar's new Quartech modules have raised the module efficiency to a new standard in the solar industry. It introduced innovative four busbar cell technology which demonstrated higher power output and higher system reliability. Our worldwide customers have embraced this next generation modules for their excellent performance, superior reliability and enhanced value.

#### QUARTECH MODULE | NEW TECHNOLOGY

- Reduces cell series resistance
- Reduces stress between cell interconnectors
- Improves module conversion efficiency
- Improves product reliability

#### PRODUCT & MANAGEMENT SYSTEM | CERTIFICATES

IEC 61215 / IEC 61730: VDE/CE

ISO9001: 2008 | Quality management system  
 ISOTS16949:2009 | The automotive industry quality management system  
 ISO14001:2004 | Standards for environmental management system  
 QC080000:2012 | The certificate for hazardous substances process management  
 OHSAS 18001:2007 | International standards for occupational health and safety

\*Please contact your sales representative for the entire list of certificates applicable to your products

#### CANADIAN SOLAR INC.

Founded in 2001 in Canada, Canadian Solar Inc., (NASDAQ:CSIQ) is one of the world's largest and foremost solar power companies. As a leading manufacturer of solar modules and PV project developer with about 6 GW of premium quality modules deployed around the world in the past 12 years, Canadian Solar is one of the most bankable solar companies in Europe, USA, Japan and China. Canadian Solar operates in six continents with customers in over 70 countries and regions. Canadian Solar is committed to providing high quality solar products, solar system solutions and services to customers around the world.



### ELECTRICAL DATA | STC

Electrical Data	CS6V-215M	CS6V-220M
Nominal Maximum Power (Pmax)	215W	220W
Optimum Operating Voltage (Vmp)	25.5V	25.7V
Optimum Operating Current (Imp)	8.43A	8.56A
Open Circuit Voltage (Voc)	31.5V	31.6V
Short Circuit Current (Isc)	8.94A	9.08A
Module Efficiency	15.89%	16.26%
Operating Temperature	-40°C~+85°C	
Maximum System Voltage	1000V (IEC)	
Maximum Series Fuse Rating	15A	
Application Classification	Class A	
Power Tolerance	0 ~ +5W	

\*Under Standard Test Conditions (STC) of irradiance of 1000W/m<sup>2</sup>, spectrum AM 1.5 and cell temperature of 25°C.

### ELECTRICAL DATA | NOCT

Electrical Data	CS6V-215M	CS6V-220M
Nominal Maximum Power (Pmax)	155W	159W
Optimum Operating Voltage (Vmp)	23.3V	23.4V
Optimum Operating Current (Imp)	6.67A	6.78A
Open Circuit Voltage (Voc)	28.9V	29.0V
Short Circuit Current (Isc)	7.24A	7.35A

\*Under Nominal Operating Cell Temperature(NOCT), irradiance of 800 W/m<sup>2</sup>, spectrum AM 1.5, ambient temperature 20°C.

### MODULE | MECHANICAL DATA

Specification	Data
Cell Type	Mono-crystalline 156 x 156mm
Cell Arrangement	50 (5 x 10)
Dimensions	1638 x 826 x 40mm (64.5 x 32.5 x 1.57in)
Weight	16.0kg (35.3 lbs)
Front Cover	3.2mm tempered glass
Frame Material	Anodized aluminium alloy
J-BOX	IP67, 3 diodes
Cable	4mm <sup>2</sup> (IEC)/12AWG(UL), 900mm
Connectors	MC4 or MC4 comparable
Standard Packaging	38pcs
Module Pieces Per Container	532pcs

### TEMPERATURE CHARACTERISTICS

Specification	Data
Temperature Coefficient (Pmax)	-0.45%/°C
Temperature Coefficient (Voc)	-0.35 %/°C
Temperature Coefficient (Isc)	0.060 %/°C
Nominal Operating Cell Temperature	45±2°C

### PERFORMANCE AT LOW IRRADIANCE

Industry leading performance at low irradiation environment, +96.5% module efficiency from an irradiance of 1000w/m<sup>2</sup> to 200w/m<sup>2</sup> (AM 1.5, 25 °C)

\*The specifications made herein may deviate slightly and are not guaranteed. Due to ongoing innovation, research and product enhancement we reserve the right to make any adjustments to the information contained herein at any time without notice.. Please always obtain the most recent revision of datasheet which shall be duly incorporated into the binding contract made by the parties governing all transactions related to the purchase and sale of the products described herein.

### MODULE | ENGINEERING DRAWING

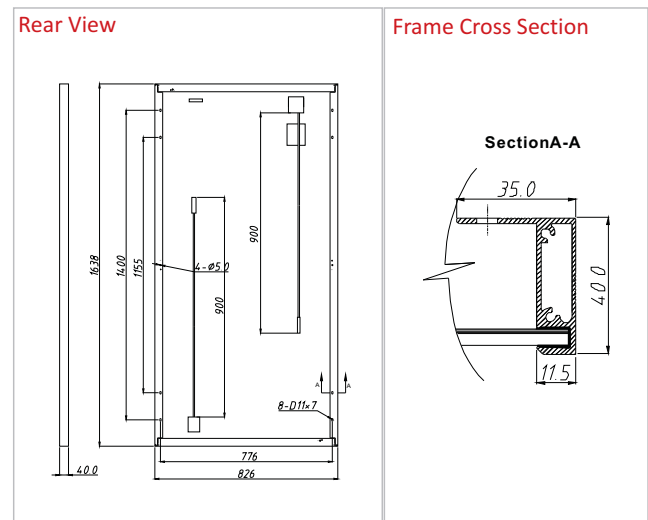

### CS6V-220M | I-V CURVES

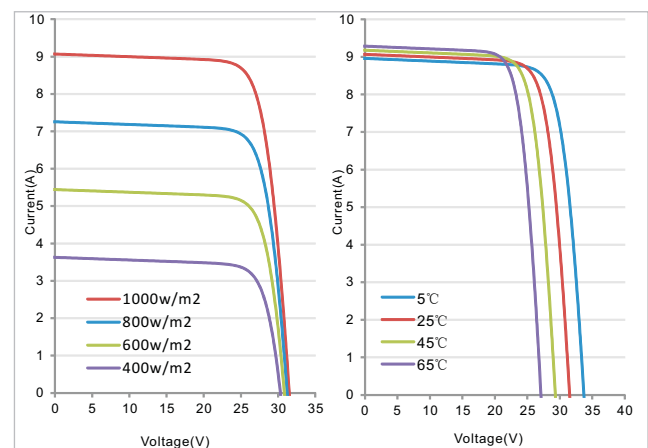

### Partner Section