

High Frequency Resistor Programmable Universal Active Filter

Preliminary Data Sheet

MSU1HF1/4, MSU2HF1

Electrical Characteristics

PARAMETERS	SYMBOL	CONDITIONS	MIN	TYP	MAX	UNITS
DC Specifications						
Operating Voltage	VDD		4.5	5.0	5.5	V
Supply Current	IDD	MSU2HF1 PWR = 1		8		mA
		MSU2HF1 PWR = 0		25		mA
		MSU1HF1/3		6		mA
		MSU1HF2/4		15		mA
Output Impedance			700			ohm
Output Offset			20			mV
AC Specifications						
Output Swing			4.0	4.5		Vp-p
Input Impedance	Zin			1		Mohm
Nominal Sample to corner	Fo	MSU2HF1 FO = 1		6.25		
		FO = 0		12.5		
		MSU1HF1/2		6.25		
		MSU1HF3/4		12.5		
Center/Corner Range note(1)		MSU2HF1 PWR = 1		100		KHz
		PWR = 0		500		KHz
		MSU1HF1/3		100		KHz
		MSU1HF2/4		500		KHz
Clock Input Voltage	CKin		0.1note(2)	5		Vp-p

note(1): the clock to corner ratio is one-half the sample to corner ratio

note(2): 100mV sine wave clock requires capacitive coupling

Block Diagram

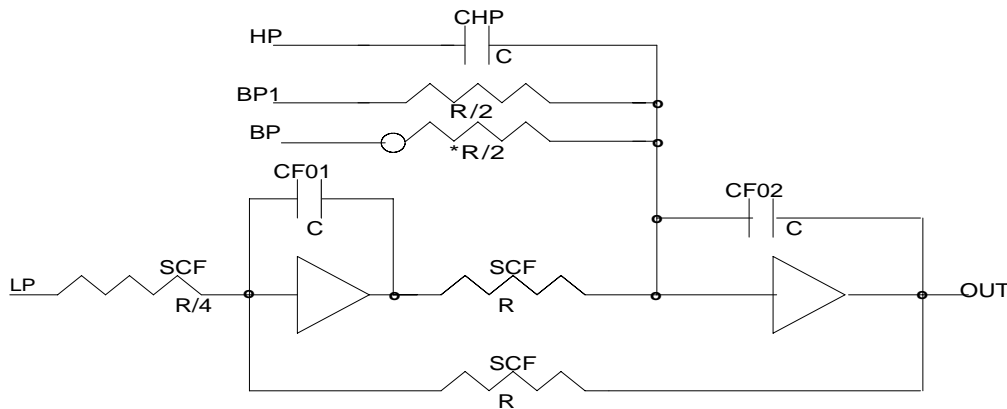

*BPP input is noninverting

High Frequency Resistor Programmable Universal Active Filter

Preliminary Data Sheet

MSU1HF1/4, MSU2HF1

Pin Description _____

16 Pin	8 Pin		
1		PWR	Power Select Pin 0 = High 1 = Low
2	8	VSS	Negative Supply, Typically 0V for single supply, - 2.5 V for dual supply
3	1	OUT1	Section One Output
4	5	GND	Ground Reference, Typically 2.5V for single supply, 0V for dual supply
5	2	LP1	Section One Lowpass Input
6	3	BPN1	Section One Negative Bandpass Input
7		BPP1	Section One Positive Bandpass Input
8	4	HP1	Section One High Pass Input
9		HP2	Section Two High Pass Input
10		BPP2	Section Two Positive Bandpass Input
11		BPN2	Section Two Negative Bandpass Input
12		LP2	Section Two Lowpass Input
13	6	CLK	Input Clock, Typically 200mV for AC coupled sine wave, 5V for CMOS input
14		OUT2	Section Two Output
15		FO	Clock to Center/Corner, Select Pin, Low = 6.25 to 1 High = 3.125 (sample rate is 2x)
16	7	VDD	Positive Supply, Typically 5V for single supply, 2.5V for dual supply

Pin Configuration _____

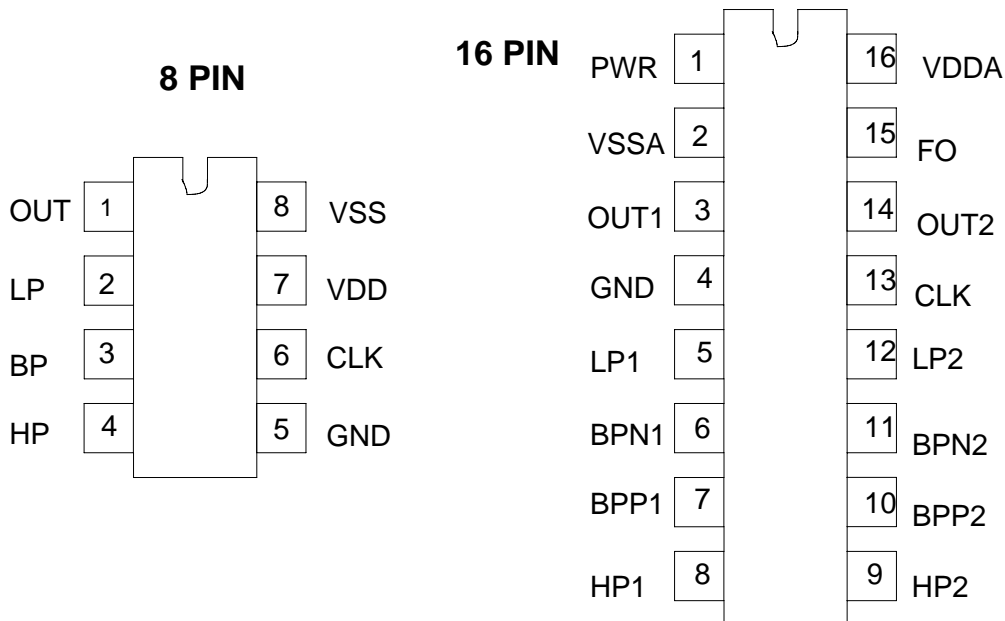

High Frequency Resistor Programmable Universal Active Filter

Preliminary Data Sheet

Filter Types Available _____

Block Diagram _____

MSU2HF1 MSU1HF1/4

Lowpass	yes	yes
Bandpass	yes	yes
Highpass	yes	yes
Lowpass elliptical	yes	yes
Highpass elliptical	yes	yes
Notch	yes	yes
Oscillator	yes	no
Allpass	yes	no
Biquad	yes	no

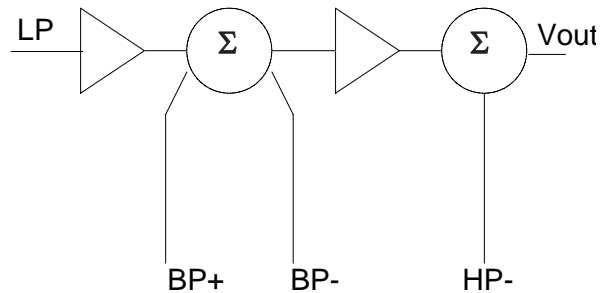

Programming Non-Linearities _____

Transfer Functions _____

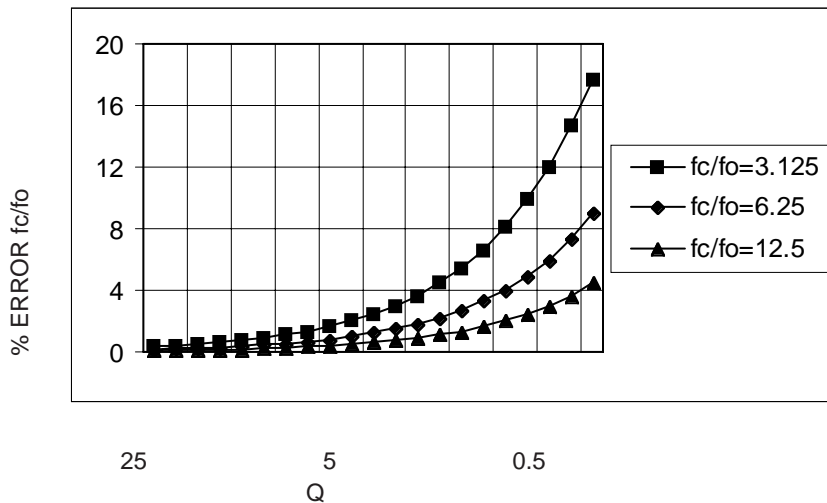
Lowpass

$$H(s) = - \frac{\omega_0^2}{s^2 + (\omega_0/Q)s + \omega_0^2}$$

Bandpass

$$H(s) = \frac{-(\omega_0/Q)s}{s^2 + (\omega_0/Q)s + \omega_0^2}$$

Highpass

$$H(s) = \frac{s^2}{s^2 + (\omega_0/Q)s + \omega_0^2}$$

Lowpass Elliptic

$$H(s) = \frac{(\omega_0/\omega_z)^2 s^2 + \omega_0^2}{s^2 + (\omega_0/Q)s + \omega_0^2}$$

Highpass Elliptic

$$H(s) = \frac{s^2 + (\omega_z/\omega_0)^2 \omega_0^2}{s^2 + (\omega_0/Q)s + \omega_0^2}$$

Notch

$$H(s) = \frac{s^2 + \omega_0^2}{s^2 + (\omega_0/Q)s + \omega_0^2}$$

Allpass

$$H(s) = \frac{s^2 - (\omega_0/Q)s + \omega_0^2}{s^2 + (\omega_0/Q)s + \omega_0^2}$$

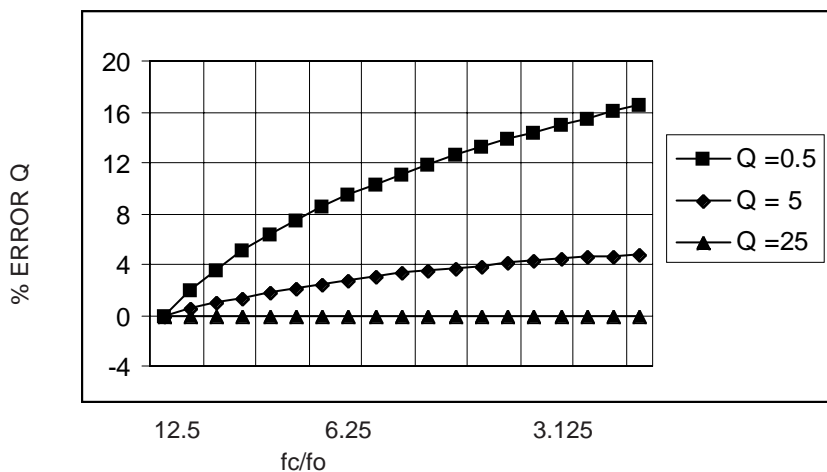
MSU1HF1/4, MSU2HF1

High Frequency Resistor Programmable Universal Active Filter

Preliminary Data Sheet

MSU1HF1/4, MSU2HF1

NOTE: $f_c > 36 \cdot f_0$

For lowpass, lowpass elliptical, highpass elliptical, allpass and notch filters. This limitation due to the particular ratio of R_1 and R_2 and allows realizable values of R_3 . Other minimum values of f_c/f_0 can be obtained by using other values of R_1 and R_2 in the basic biquad equations.

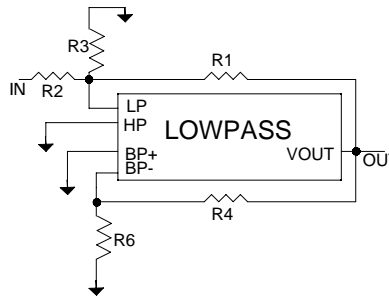

Assumption (1) $R_1 = R_2$; DC Gain = Unity

$$f_0 = \frac{\sqrt{K_1}}{\alpha(2)} \cdot f_c \quad K_1 = \frac{R_3}{R_1 + 2R_3}$$

$$Q = \frac{\sqrt{K_1}}{K_2} \quad K_2 = \frac{R_6}{R_4 + R_6}$$

- (1) If a gain other than unity is desired then gain = R_1/R_2 and K_1 from the biquad equations should be substituted for K_1
- (2) where α is 6.25 or 12.5.

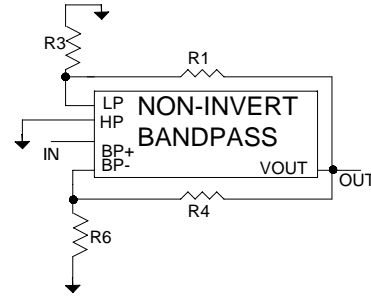

$$\text{Gain (1)} = \frac{1}{K_2}$$

$$f_0 = \frac{\sqrt{K_1}}{\alpha(2)} \cdot f_c \quad K_1 = \frac{R_3}{R_1 + R_3}$$

$$Q = \frac{\sqrt{K_1}}{K_2} \quad K_2 = \frac{R_6}{R_4 + R_6}$$

- (1) Gain may be adjusted independent of Q using the resistor divider described by K_5 from the biquad equations. Use the K_5 equation in place of K_2 for the gain equation only.
- (2) where α is 6.25 or 12.5.

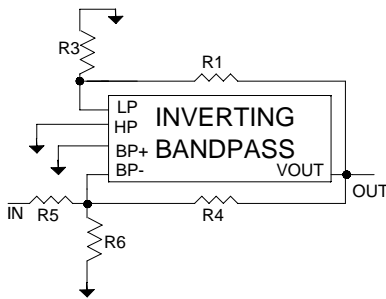

Assumption(1) $R_4 = R_5$; Gain = Unity

$$f_0 = \frac{\sqrt{K_1}}{\alpha(2)} \cdot f_c \quad K_1 = \frac{R_3}{R_1 + R_3}$$

$$Q = \frac{\sqrt{K_1}}{K_2} \quad K_2 = \frac{R_6}{R_4 + 2R_6}$$

- (1) For gains not equal to unity, gain = R_4/R_5 and K_2 should be replaced with K_2 from the biquad equations.
- (2) where α is 6.25 or 12.5.

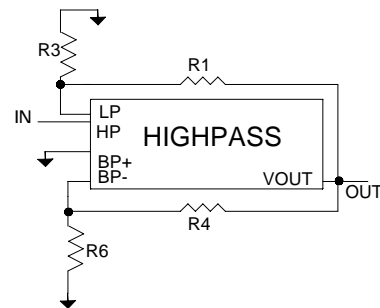

Gain = Unity

$$f_0 = \frac{\sqrt{K_1}}{\alpha(1)} \cdot f_c \quad K_1 = \frac{R_3}{R_1 + R_3}$$

$$Q = \frac{\sqrt{K_1}}{K_2} \quad K_2 = \frac{R_6}{R_4 + R_6}$$

High Frequency Resistor Programmable Universal Active Filter

Preliminary Data Sheet

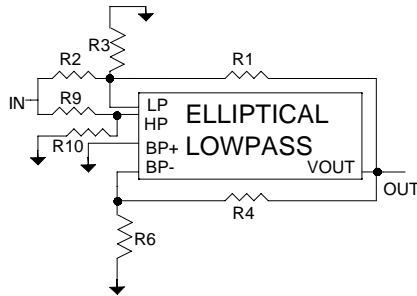
MSU1HF1/4, MSU2HF1

DC Gain (1) = Unity; $R_1 = R_2$

$$f_0 = \sqrt{K_1} \cdot \frac{f_c}{\alpha} \quad K_1 = \frac{R_3}{R_1 + 2R_3}$$

$$Q = \frac{\sqrt{K_1}}{K_2} \quad K_2 = \frac{R_6}{R_4 + R_6}$$

$$f_z = \sqrt{\frac{1}{K_3}} \cdot f_0 \quad K_3 = \frac{R_{10}}{R_9 + R_{10}}$$

- (1) For gain other than unity, gain = R_1/R_2 and K_1 from the bequard equation should be substituted for K_1 . The $\sqrt{1/K_3}$ term should also be multiplied by the gain.
 (2) where α is 6.25 or 12.5.

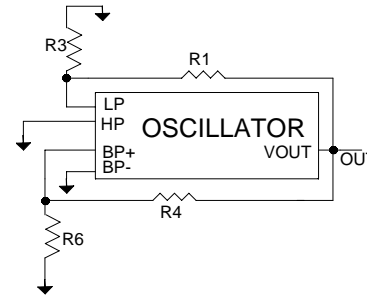

$$(1) \quad (2) \quad f_0 = \sqrt{\frac{R_3}{R_1 + R_3}} \cdot \frac{f_c}{\alpha} \quad \frac{R_4}{R_6} \cong 20$$

- (1) f_0 is also a function of the feedback coefficient defined by R_4 and R_6 and can vary considerably from the calculated value. For a fixed feedback coefficient, f_0 will not vary by more than plus or minus 1%.
 (2) The distortion of the sine wave can be adjusted by varying this ratio.
 (3) where α is 6.25 or 12.5.

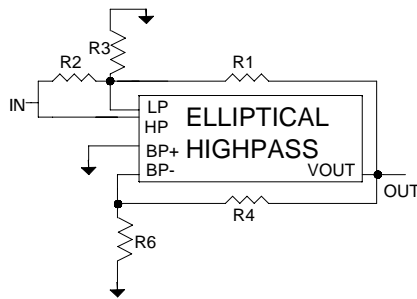

Gain = Unity

$$(1) f_0 = \sqrt{K_1} \cdot \frac{f_c}{\alpha}$$

$$Q = \frac{\sqrt{K_1}}{K_2} \quad K_1 = \frac{R_2 R_3}{R_1 R_2 + R_1 R_3 + R_2 R_3}$$

$$f_z = \sqrt{\frac{R_1}{R_2}} \cdot f_0 \quad K_2 = \frac{R_6}{R_4 + R_6}$$

- (1) For this case only, the resistor value R_1 and R_2 should be determined for f_z before the resistor values for f_0 (R_3) are calculated
 (2) where α is 6.25 or 12.5.

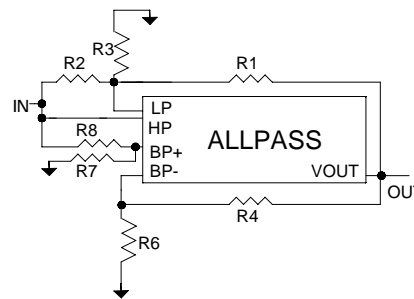

Gain = Unity; $R_1 = R_2$; $R_7 = R_4$; $R_8 = R_6$

$$f_0 = \sqrt{K_1} \cdot \frac{f_c}{\alpha} \quad K_1 = \frac{R_3}{R_1 + 2R_3}$$

$$Q = \frac{\sqrt{K_1}}{K_2} \quad K_2 = \frac{R_6}{R_4 + R_6}$$

- (1) where α is 6.25 or 12.5.

High Frequency Resistor Programmable Universal Active Filter Preliminary Data Sheet

MSU1HF1/4, MSU2HF1

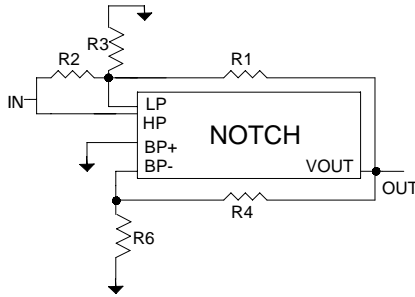

Gain = Unity; $R_1 = R_2$

$$f_0 = \frac{\sqrt{K_1}}{\alpha} \cdot \frac{fc}{\alpha} \quad K_1 = \frac{R_3}{R_1 + 2R_3}$$

$$Q = \frac{\sqrt{K_1}}{K_2} \quad K_2 = \frac{R_6}{R_4 + R_6}$$

(1) where α is 6.25 or 12.5.

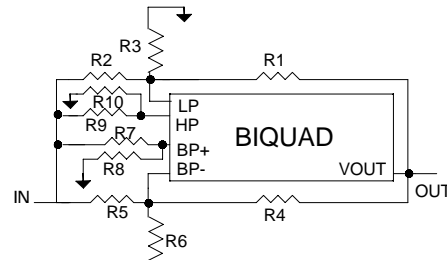

The biquad is the most general purpose filter type. By adjusting the values of K1 through K6, virtually any second order transfer function can be achieved. In some cases, it may be necessary to use an inverting op amp to achieve the correct polarity on these constants.

$$VOUT = VIN \left[\frac{-K_3 S^2 - K_4 S \frac{fc}{4} + K_5 S \frac{fc}{4} - K_6 \frac{fc^2}{16}}{S^2 \frac{K_2 S \frac{fc}{4} + K_1 \frac{Fc^2}{16}}{4}} \right]$$

$$K_1 = \frac{R_2 R_3}{R_1 R_2 + R_1 R_3 + R_2 R_3} \quad K_4 = \frac{R_4 R_6}{R_4 R_5 + R_4 R_6 + R_5 R_6}$$

$$K_2 = \frac{R_5 R_6}{R_4 R_5 + R_4 R_6 + R_5 R_6} \quad K_5 = \frac{R_8}{R_7 + R_8}$$

$$K_3 = \frac{R_{10}}{R_9 + R_{10}} \quad K_6 = \frac{R_1 R_3}{R_1 R_2 + R_1 R_3 + R_2 R_3}$$