

Resistor Programmable Active Audio Filter Preliminary Data Sheet

MSRAAF

Description

The resistor programmable continuous audio active filter IC is a CMOS chip that can be configured for either a lowpass, bandpass, highpass, allpass or notch filter. Butterworth, Bessel, elliptic and Chebyshev filters can be implemented. The frequency range covers the audio spectrum to 20 kHz. There is a low power version with a frequency range to 5 kHz. There is a power down pin to reduce current consumption when the filter is not in use. The 8 pin part is a single filter stage, the 16 pin part offers a dual filter stage. Between 2 and 5 external resistors set the filter characteristics depending on the desired response. Q can be set from between 0.25 and 50. No clock signal is required.

Features

- Independent Q, frequency and gain adjustments
- Low sensitivity to external resistor variation
- Operates up to 20 kHz
- Q range from 0.25 to 50
- Low Power Operation
- Low Voltage Operation
- On Chip Power Save Pin
- Cascadable for Higher Order Filtering

Applications

- Spectrum Analyzers
- General Purpose Systems
- Portable Systems
- Anti-Alias Filters
- Reconstruction Filters
- Telecommunications
- Tracking Filters
- Harmonic Analysis
- Noise Analysis
- Data Communication
- Wireless Applications

Block Diagram

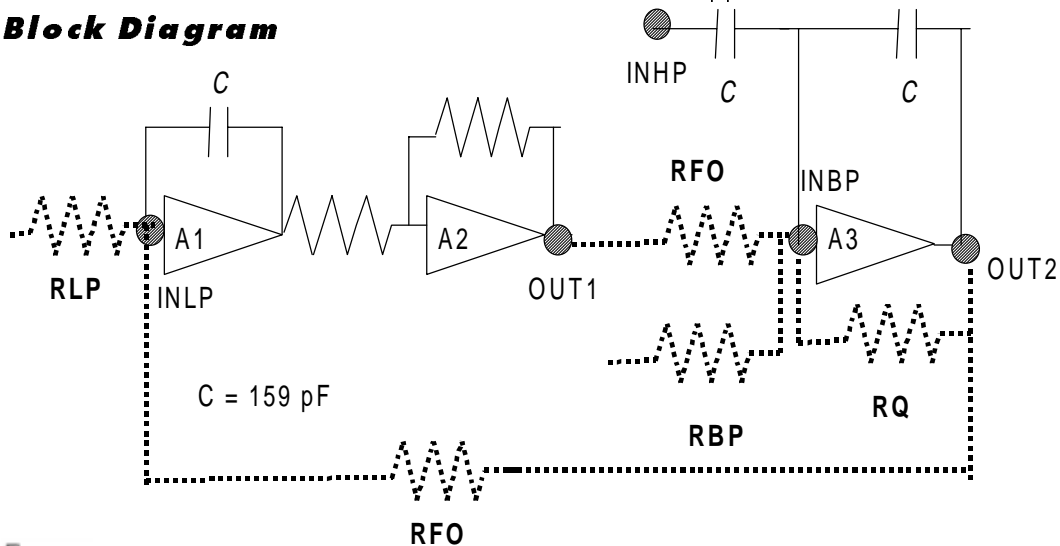



Resistor Programmable Active Audio Filter Preliminary Data Sheet

9/99

MSRAAF

Electrical Characteristics

(VDD = +5.0V, T = 25 °C)

PARAMETER	SYMBOL	CONDITIONS	MIN	TYP	MAX	UNITS
DC Specifications						
Operating Voltage	VDD		2.7	5	5.5	V
Supply Current	IDD	MSRAAF1; or MSRAAF2 and PWR = HI		2		mA
Supply Current	IDD	MSRAAF3, or MSRAAF2 and PWR = LO		220		uA
Power Down Current		PD = HI		100		uA
AC Specifications						
Gain	Av		-0.5	0	0.5	dB
Signal to Noise Ratio				95		dB
Distortion	THD				0.1	%
Signal Swing		1 kHz	3.5	4		V p-p
Input Impedance	ZIN	fIN = 1 kHz		1		Mohm
Output Drive	Io			1		mA
Output Impedance	Zo	fIN = 1 kHz		500		ohm
Output Capacitive Load				50		pF
Center Frequency Range	Fo	PWR = HI	50		80	kHz
Center Frequency Range	Fo	PWR = LOW	50		10	kHz
fo Accuracy				+/- 3		%
Q Range	Q		0.25		50	



Resistor Programmable Audio Active Filter Preliminary Data Sheet

MSRAAF

Pin Description

16 Pin Package

- 1. VDDA Positive Power Supply, Typically 2.5 Volts for Split Supply, 5.0 Volts for Single Supply
- 2. OUTA 2 Output 2 for Channel A
- 3. OUTA 1 Output 1 for Channel A
- 4. INBPA Bandpass Input for Channel A
- 5. INHPA Highpass Input for Channel A
- 6. INLPA Lowpass Input for Channel A
- 7. VSS Negative Power Supply, Typically -2.5 Volts for Split Supply, 0 Volts for Single Supply
- 8. PD Power Down Pin, CMOS level, Hi = Power Down
- 9. GND GND Pin, 0V for Split Supplies, 2.5 Volts Typical for Single Supply
- 10. BIAS Bias Pin (OPEN)
- 11. INLPB Low Pass Input for Channel B
- 12. INHPB High Pass Input for Channel B
- 13. INBPB Band Pass Input for Channel B
- 14. OUTB 1 Output 1 for Channel B
- 15. OUTB 2 Output 2 for Channel B
- 16. PWR Set Bias Current for Filter Stages, LO=Low power, HI=normal power

8 Pin Package

- 1. OUT 1 Output 1
- 2. OUT 2 Output 2
- 3. VDD Positive Power Supply, Typically 2.5 Volts for Split Supply, 5.0 Volts for Single Supply
- 4. GND Ground Pin, 0V for Split Supplies, 2.5 Volts Typical for Single Supply
- 5. INLP Low Pass Input
- 6. VSS Negative Power Supply, Typically -2.5 Volts for Split Supply, 0 Volts for Single Supply
- 7. INHP High Pass Input
- 8. INBP Band Pass Input

Ordering Information

Part Number	Package
MSRAAF1P	8 Pin DIP
MSRAAF2P	16 Pin DIP
MSRAAF3P	8 Pin DIP
MSRAAF1S	8 Pin SOIC
MSRAAF2S	16 Pin SOIC
MSRAAF3S	8 Pin SOIC

Pin Configuration

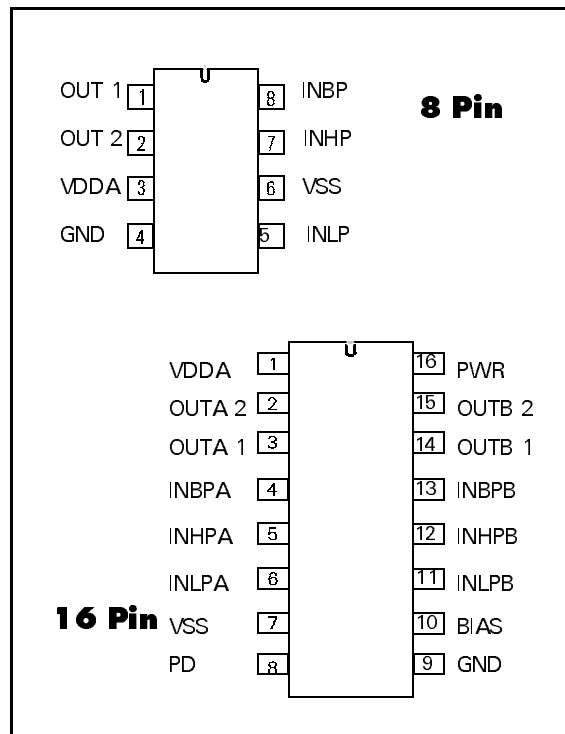



Resistor Programmable Audio Active Filter Preliminary Data Sheet

MSRAAF

$RFO = 1E9/Fo$

$RA = RFO$

$RQ = Q * RFO$

LOWPASS

KLP = Lowpass Gain

$RLP = RFO/KLP ; RBP = \infty ; INHP \text{ to GND}$

BANDPASS

KBP = Bandpass Gain

$RBP = RFO/KBP * Q ; RLP = \infty ; INHP \text{ to GND}$

HIGH PASS

Gain = 1

$RLP = \infty ; RBP = \infty$

NOTCH

$RLP = RFO ; RBP = \infty$

ALL PASS

An External Op Amp Inverter is required

$RLP = RFO ; RBP = RQ ; R1 = R2$

LOW PASS NOTCH

An External Resistor Divider is required on INHP

$RLP = RFO ; RBP = \infty$

$FZ = Fo * (R2/(R1 + R2))^{**}1/2 ;$

HIGHPASS NOTCH

$RLP = \{(Fz/Fo)^{**} (1/2)\} * RFO ; RBP = \infty$

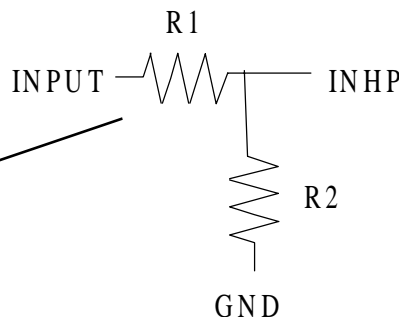
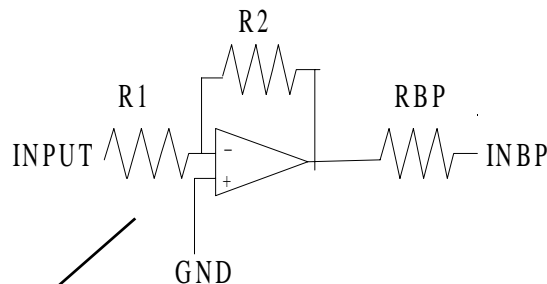

Absolute Maximum Ratings

Power Supply Voltage	+6V
Storage Temperature	-60 to +150 C
Operating Temperature	0 to 70 C

Digital Levels

The PD is referenced between GND and VDD. In single supply applications, the digital level should be CMOS levels from VSS to VDD. In dual supply systems, the digital level should be CMOS levels from GND to VDD. The PWR pin should be connected to VSS or VDD.



Resistor Programmable Audio Active Filter Preliminary Data Sheet

MSRAAF

Typical Application Circuits

