

Selectable Lowpass/Bandpass Filter Data Sheet

Description

The selectable lowpass/ bandpass filter IC is a CMOS chip that can be configured for either a lowpass or a bandpass filter. The lowpass response can be a 7 pole Butterworth, Elliptic or Bessel filter. The band pass response can be a six pole full, third or sixth octave bandpass filter. The device uses switched-capacitor filters and no external components (except for decoupling capacitors) are required, Only an external CMOS level clock is needed.

A four input multiplexor and externally selectable gain setting pin, along with a power down and clock to corner ratio select pin are included in the 16 pin version. An 8 pin version is also available for PC board area savings. Typical current consumption is as low as 200 uA and the minimum operating voltage is 2.7 volts, making the device ideal for portable applications. MSFS3, MSFS4 and MSFS6 are low current, lower frequency versions.

Features

- Six Filter Types In One Package
- No External Components
- Switched-Capacitor Filters
- Low Power Operation
- Low Voltage Operation
- Input Multiplexor
- Adjustable Gain 0, 10 or 20 dB
- Small Package Size
- Low Cost
- On Chip Power Save Pin
- ANSI Compatible Bandpass

Applications

- Spectrum Analyzers
- General Purpose Systems
- Portable Systems
- Anti-Alias Filters
- Reconstruction Filters
- Telecommunications
- Tracking Filters
- Harmonic Analysis
- Noise Analysis
- Data Communication
- Wireless Applications

Low pass Responses

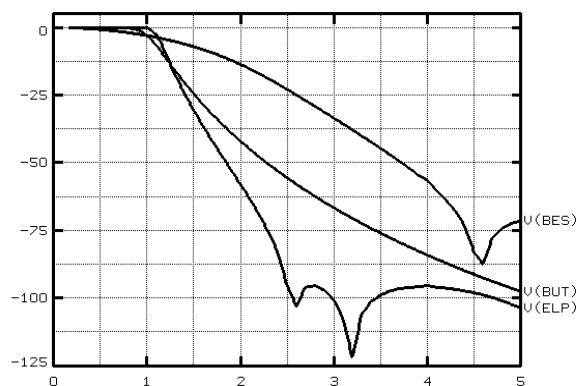

Bandpass Responses

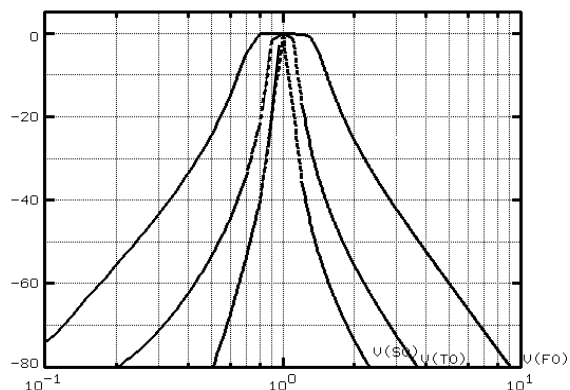



Selectable Lowpass/Bandpass Filter Data Sheet

Electrical Characteristics _____

(VDD = +5.0V, T = 25° C)

PARAMETER	SYMBOL	CONDITIONS	MIN	TYP	MAX	UNITS
DC Specifications						
Operating Voltage	VDD		2.7	5	5.5	V
Supply Current	IDD	MSFS1, MSFS2, MSFS5		1	1.5	mA
Supply Current	IDD	MSFS3, MSFS4, MSFS6		200	300	uA
Power Down Current	IPD	MSFS2, MSFS4, PD = 1		150		uA
AC Specifications						
Gain	Av		-0.5	0	0.5	dB
Noise		To 1/2 Sample		250		uVrms
Distortion	THD	A weighted		-72		dB
Signal Swing		1 kHz	4	4.5		V p-p
Input Impedance	ZIN			1		Mohm
Output Drive	Io			1		mA
Output Impedance	Zo			500		ohm
Output Capacitive Load				25		pF
Clock to Corner		MSFS5, MSFS6	99	100	101	
Clock to Corner		MSFS1, MSFS3	49.5	50	50.5	
Clock to Corner		MSFS2, MSFS4, Fo=1	99	100	101	
Clock to Corner		MSFS2, MSFS4, Fo=0	49.5	50	50.5	
Center Frequency Range	Fo	MSFS1, MSFS2, MSFS5	0.001		20	kHz
Center Frequency Range	Fo	MSFS3, MSFS4, MSFS6	0.001		3	kHz
Ripple						
Elliptic Lowpass				0.2		dB
Full Octave				0.2		dB
Third Octave				0.2		dB
Sixth Octave				0.2		dB
Stop Band Rejection						
Elliptic Lowpass				80		dB
Bessel Lowpass				65		dB
40 dB Bandwidth						
Full Octave		Normalized Fo	0.3		3	
Third Octave		Normalized Fo	0.6		1.67	
Sixth Octave		Normalized Fo	0.76		1.32	
Bandpass Q						
Full Octave Q	Q			1.5		
Third Octave	Q			4.5		
Sixth Octave	Q			9		

MSFS1 / MSFS2 / MSFS3 / MSFS4 / MSFS5 / MSFS6



Selectable Lowpass/Bandpass Filter Data Sheet

M SFS1 / M SFS2 / M SFS3 / M SFS4 / M SFS5 / M SFS6

Filter Selection

The filter type is selected using the two filter select pins, TYPE and FSEL, FSEL is a CMOS level pin that selects lowpass or bandpass (lowpass = 0, bandpass = 1). TYPE is a tertiary control pin that selects the filter response. State 0 is VSS, state 1 is GND and state 2 is VDD.

TYPE	Lowpass	Bandpass
0	Butterworth	Full Octave
1	Bessel	Third Octave
2	Elliptic	Sixth Octave

Gain and Frequency Selection

The Gain control pin G is a tertiary control pin where state 0 is VSS, state 1 is GND level and state 2 is VDD.

G	Gain
0	0dB
1	10dB
2	20dB

The frequency control pin F0 is a CMOS level pin where high is clock to corner of 100 to 1 (200 to 1 for Bessel) and low is clock to corner of 50 to 1 (100 to 1 for Bessel).

Pin Description

- 1. TYPE Filter Response Select Pin.
- 2. S2 Input Multiplexor Select Pin
- 3. CLK Clock Input
- 4. G Gain Select Pin
- 5. VDD Positive Power Supply, Typically 2.5 Volts for Split Supply 5.0 Volts for Single Supply
- 6. PD Power Down Pin, CMOS level, Hi = Power Down
- 7, VSS Negative Power Supply, Typically -2.5 Volts for Split Supply. 0 Volts for Single Supply
- 8. F0 Clock to Corner Select Pin
- 9. GND GND Pin, 0V for Split Supplies 2.5 Volts Typical for Single Supply
- 10. IN1 Input 1, Select Code 00
- 11. IN2 Input 2, Select Code 01
- 12. IN3 Input 3, Select Code 10
- 13. IN4 Input 4, Select Code 11
- 14. FSEL Selects Filter.
0 = Low Pass, 1 = Bandpass
- 15. Out Filter Output
- 16. S1 Input Multiplexor Select Pin

Pin Configuration

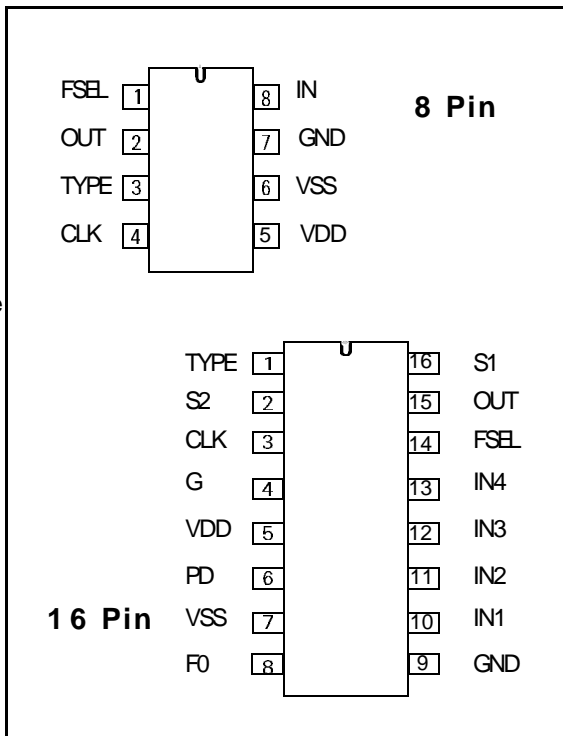



Selectable Lowpass/Bandpass Filter Data Sheet

M SFS1 / M SFS2 / M SFS3 / M SFS4 / M SFS5 / M SFS6

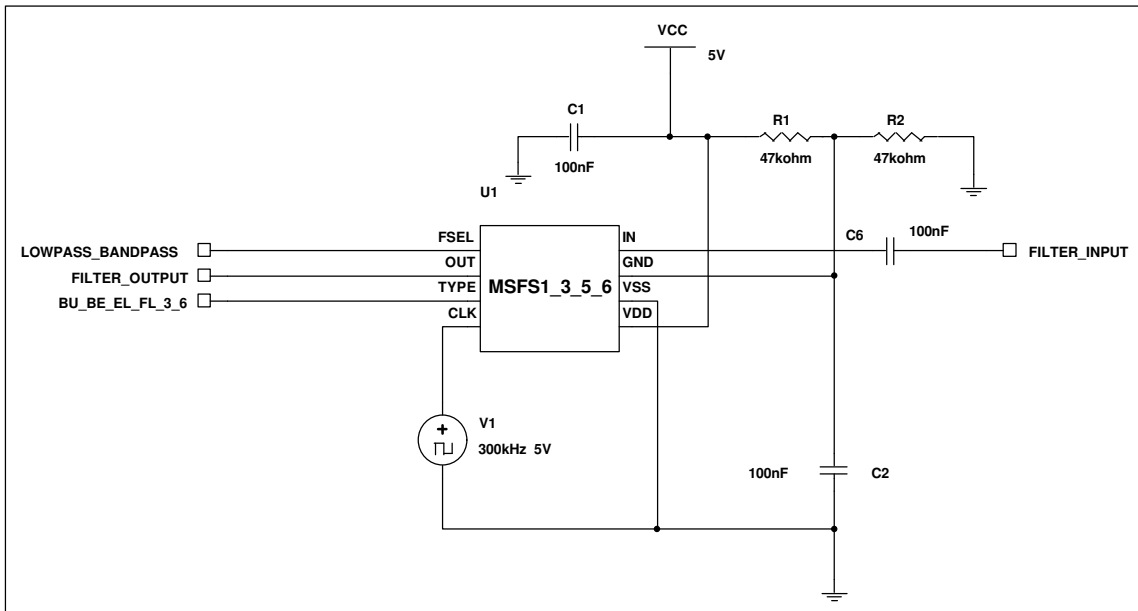

Typical Application-Single Supply Operation



Selectable Lowpass/Bandpass Filter Data Sheet

M SFS1 / M SFS2 / M SFS3 / M SFS4 / M SFS5 / M SFS6

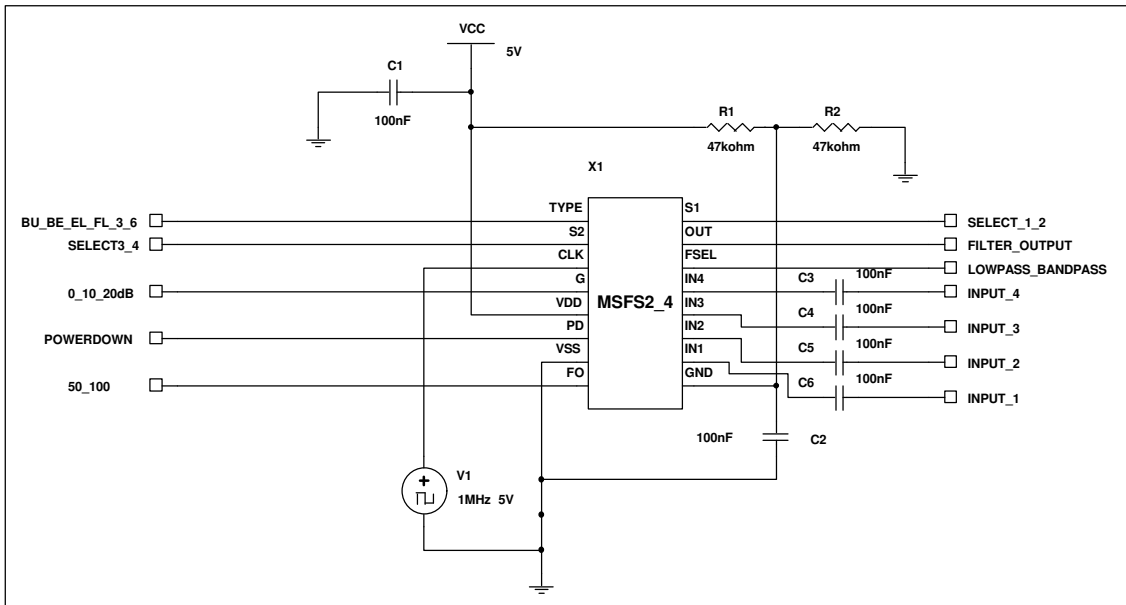

Typical Application-Single Supply Operation



03/2001

Selectable Lowpass/Bandpass Filter Data Sheet

MSFS1 / MSFS2 / MSFS3 / MSFS4 / MSFS5 / MSFS6

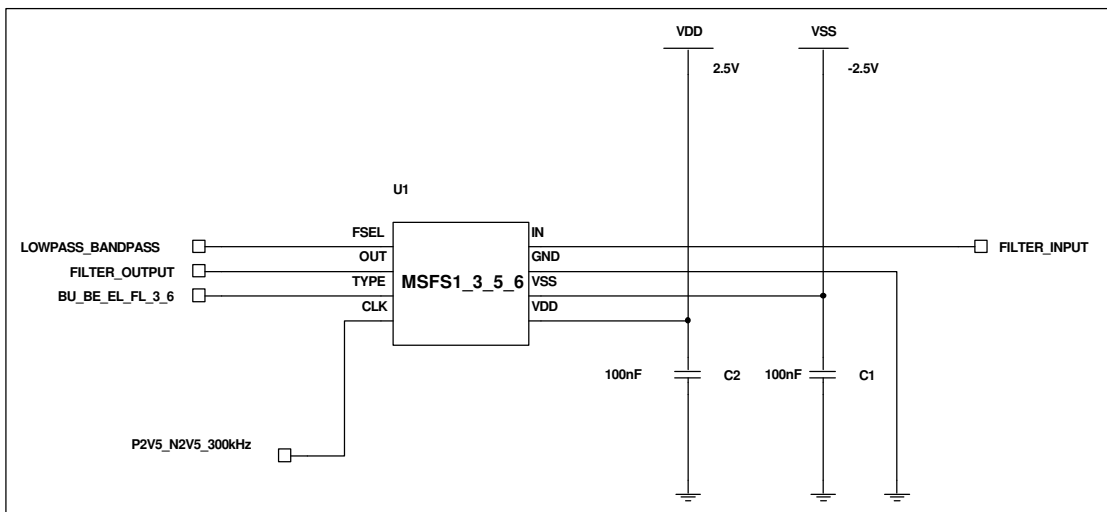

Typical Application-Dual Supply Operation





Selectable Lowpass/Bandpass Filter Data Sheet

M SFS1 / M SFS2 / M SFS3 / M SFS4 / M SFS5 / M SFS6

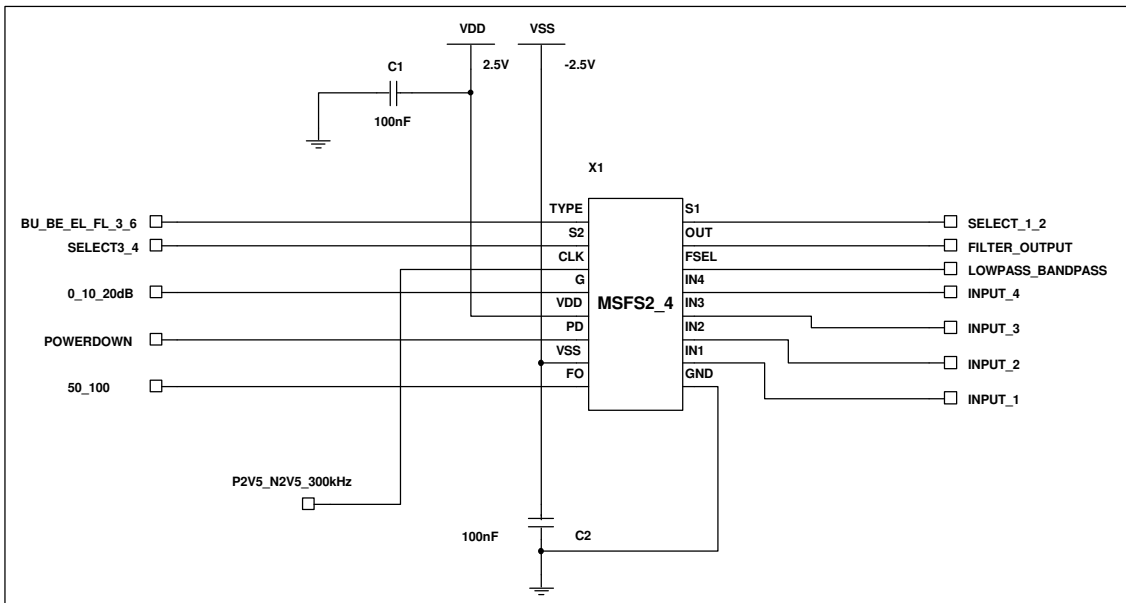

Typical Application-Dual Supply Operation





Selectable Lowpass/Bandpass Filter Data Sheet

Block Diagram

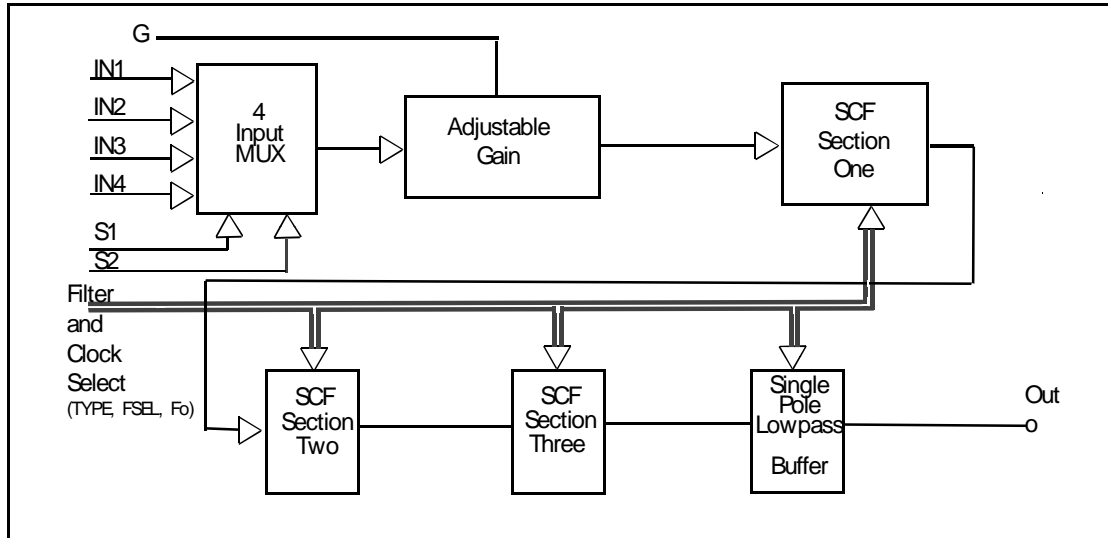

Absolute Maximum Ratings

Power Supply Voltage	+6V
Storage Temperature	-60 to +150 C
Operating Temperature	0 to 70 C

Digital Levels

All the clock and control pins (except TYPE and G) are referenced between GND and VDD. In single supply applications, the digital levels should be CMOS levels from VSS to VDD. In dual supply systems, the digital levels should be CMOS levels from GND to VDD.

Ordering Information

Part Number	Package	Clock to Corner Ratio
MSFS1P	8 Pin DIP	50
MSFS2P	16 Pin DIP	50 or 100
MSFS3P	8 Pin DIP	50
MSFS4P	16 Pin DIP	50 or 100
MSFS5P	8 Pin DIP	100
MSFS6P	8 Pin DIP	100
MSFS1S	8 Pin SOIC	50
MSFS2S	16 Pin SOIC	50 or 100
MSFS3S	8 Pin SOIC	50
MSFS4S	16 Pin SOIC	50 or 100
MSFS5S	8 Pin SOIC	100
MSFS6S	8 Pin SOIC	100

Input Selection

The input is selected using the Input Select Pins S1 and S2.

S2	S1	Input
0	0	1
0	1	2
1	0	3
1	1	4

MSFS1 / MSFS2 / MSFS3 / MSFS4 / MSFS5 / MSFS6

