



TECHNICAL DATA SHEET
LITHIUM ION
RECHARGEABLE BATTERY

PB-LW-08

BATTERY SPECIFICATIONS



| | |
|--|-----------------|
| Model No: PB-LW-08 | NSN: TBD |
| Manufacturers CAGE Code: 03UN7 | |
| Voltage Range: 7.5V min.; 11.1V nom.; 12.6V max. | |
| Nominal Capacity: 4.8 Ah @ 500mA @ 23°C (74°F) | |
| Maximum Discharge: 3.0 A continuous @ 23°C (74°F) | |
| Maximum Pulse Discharge: 5.0 A for 5 seconds @ 23°C (74°F) | |
| Energy: 53 Wh | |
| Energy Density: 129 Wh/kg, 165 Wh/l | |
| Weight: 410 grams (0.91 lbs.) max. | |
| Cycle Life: > 300 cycles @ C/5 to 80% of initial capacity @ 100% depth of discharge | |
| Operating Temp: -20° C to 60° C (-4°F to 140°F) | |
| Storage Temp: -20° C to 60° C (-4°F to 140°F) | |
| Self-Discharge: < 3% per month @ 25°C (77°F) | |
| Housing: Hard plastic, lusterless, black, UL 94 V-0 | |
| Connector: LEMO HEN.1F.305.XLNP | |
| Mating Connector: LEMO FGN.1F.305.YLC | |
| Flat Contacts: Copper alloy with gold plating over nickel plating | |
| Communication: SMBus v1.1 communication protocol SBD v1.1 data set support | |
| State of Charge Indicator: LCD Displays | |
| Safety: See Material Safety Datasheet – MSDS046 | |
| Transportation: See MSDS046 | |
| Harmonized Tariff Code: 8507.80.0000 | |
| Charging: Charge at constant voltage of 12.6 Volts in a temperature range of 0°C to 45°C, limiting current to 2.4 A max, at 23°C, until current declines to 200 mA. | |

APPLICATIONS

- Military Training Systems
- Back-up Server Power
- Ruggedized Portable Electronics

KEY FEATURES

- SMBus v 1.1 smart battery technology compliant
- Smart battery data specification (SBD) v1.1 dataset
- Immersion compliant per MIL-STD-810G, Section 512.5
- EMI compliant per MIL-STD-461F (contact Patco Electronics for details)
- High energy density

COMPATIBLE CHARGERS

- **PC-3200M/C** 32-station bulk smart charger
- **PC-6805** 8-bay tactical portable smart charger
- **PC-6010-02** 1-bay tactical portable smart charger
- **PC-6500** dual battery desk top charger
- **PC-6200** single battery desk top charger

COMPATIBLE CABLES

- **PE-CC2-02** charge cable for PC-6200 charger
- **PE-CC2-03** charge cable for PC-6500 charger
- **PE-CC2-04** discharge cable

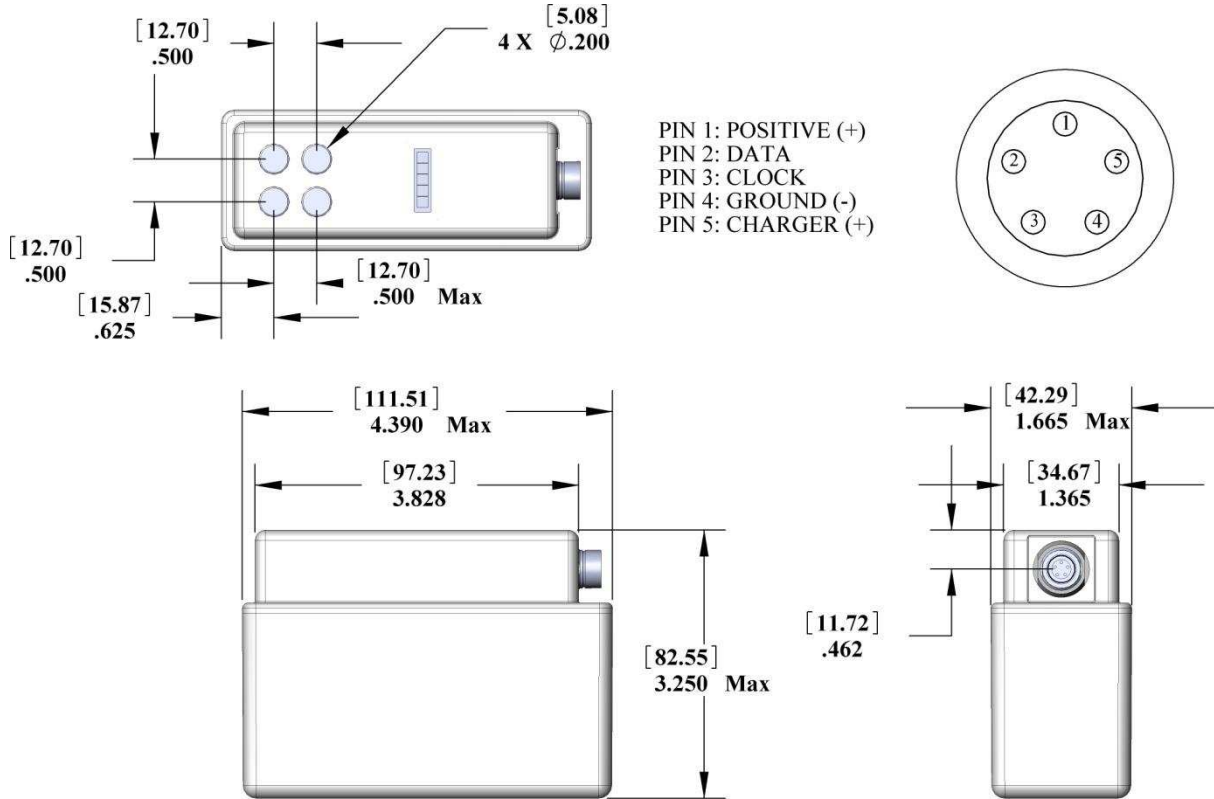

Dimension in: inches [mm]

