

The S-75V00ANC is a single 2-Input NAND Gate fabricated by utilizing advanced silicon-gate CMOS technology which provides the inherent benefit of CMOS low power consumption to achieve ultra high speed operation correspond to LSTTL IC's.

All gates of the internal circuitry have buffered outputs to ensure high noise immunity and output stability.

Input voltage is allowed to be applied even if power voltage is not supplied because no diode is inserted between an input pin and V_{CC} .

This allows for interfaces between power supplies of different voltage, output level conversion from 5 V to 3 V and battery backup applications.

■ Features

- Wide power supply range: 2 V to 5.5 V
- Low current consumption: 1.0 μ A max. (at 5.5 V, 25°C)
- Typical propagation delay: $t_{PD} = 3.7$ ns (at 5 V)
- High noise immunity: $V_{NIH} = V_{NIL} = 28\% V_{CC}$ min.
- Power down protection: All pins
- Lead-free

■ Applications

- Personal computers, peripherals
- Cellular phones
- Cameras
- Games

■ Package

- SC-88A

■ Pin Configuration

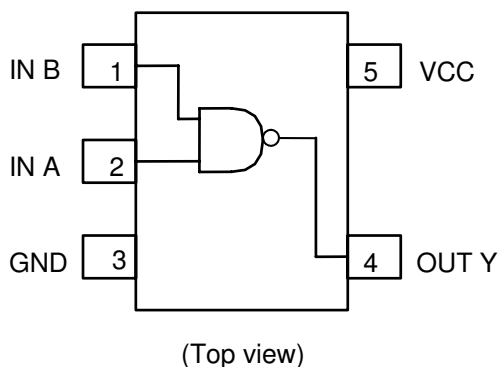

■ Marking Specification

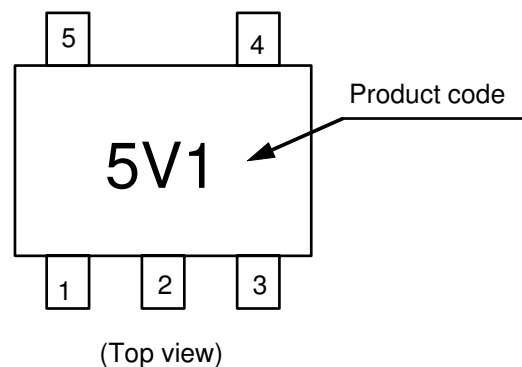

■ Logic Diagram

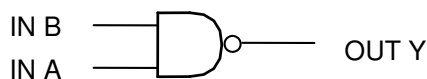

True values

| A | B | Y |
|---|---|---|
| L | L | H |
| L | H | H |
| H | L | H |
| H | H | L |

■ Product Name Structure

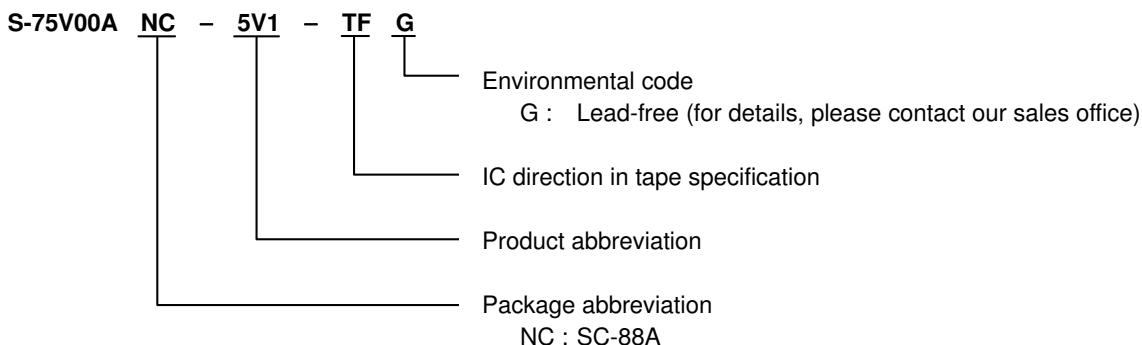

■ Absolute Maximum Ratings

(Ta = 25°C unless otherwise specified)

| Item | Symbol | Absolute Maximum Ratings | Unit |
|--------------------------------|-----------|---------------------------------|------|
| Power supply voltage | V_{CC} | -0.5 to +7.0 | V |
| Input voltage | V_{IN} | -0.5 to +7.0 | V |
| Output voltage | V_{OUT} | -0.5 to $V_{CC} + 0.5$ | V |
| Input parasitic diode current | I_{IK} | -20 | mA |
| Output parasitic diode current | I_{OK} | ±20 | mA |
| Output current | I_{OUT} | ±25 | mA |
| V_{CC} /GND current | I_{CC} | ±50 | mA |
| Power dissipation | P_D | 200 (When not mounted on board) | mW |
| | | 350*1 | mW |
| Operating ambient temperature | T_{opr} | -40 to +85 | °C |
| Storage temperature | T_{stg} | -65 to +150 | °C |
| Lead temperature (10 s) | T_L | 260 | °C |

*1. When mounted on board
[Mounted board]

- (1) Board size : 114.3 mm × 76.2 mm × t1.6 mm
- (2) Board name : JEDEC STANDARD51-7

Caution The absolute maximum ratings are rated values exceeding which the product could suffer physical damage. These values must therefore not be exceeded under any conditions.

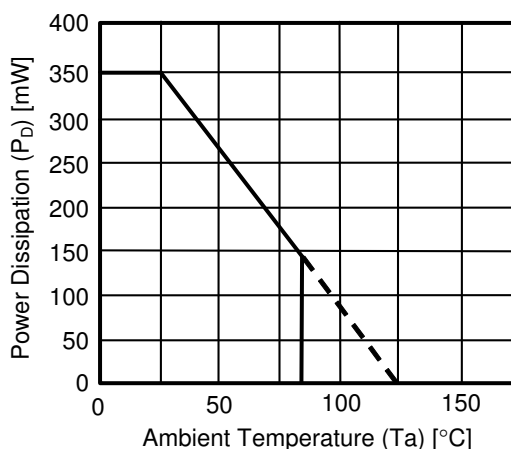

Power Dissipation of Package (When Mounted on Board)

■ Recommended Operating Conditions

| Item | Symbol | Standard | Unit |
|------------------------|------------|--------------------------------------|------|
| Power voltage | V_{CC} | 2 to 5.5 | V |
| Input voltage | V_{IN} | 0 to 5.5 | V |
| Output voltage | V_{OUT} | 0 to V_{CC} | V |
| Input rise / fall time | t_R, t_F | 0 to 100 ($V_{CC} = 3.3 \pm 0.3$ V) | ns |
| | | 0 to 20 ($V_{CC} = 5 \pm 0.5$ V) | ns |

■ DC Electrical Characteristics

| Item | Symbol | Conditions | $T_a = 25^\circ\text{C}$ | | | $T_a = -40$ to 85°C | | Unit | | | |
|-------------------------|-----------|---------------------------------|----------------------------------|----------------------------|-------------------------|-----------------------------------|---------------------|---------------------|---------------------|-----|------|
| | | | V_{CC} | Min. | Typ. | Max. | Min. | | Max. | | |
| Input voltage | "H" level | V_{IH} | — | 2.0 | 1.5 | — | — | 1.5 | — | V | |
| | | | | 3 to 5.5 | $V_{CC} \times 0.7$ | — | — | $V_{CC} \times 0.7$ | — | V | |
| | "L" level | V_{IL} | — | 2.0 | — | — | 0.5 | — | 0.5 | V | |
| | | | | 3 to 5.5 | — | — | $V_{CC} \times 0.3$ | — | $V_{CC} \times 0.3$ | V | |
| Output voltage | "H" level | V_{OH} | $V_{IN} = V_{IL}$ or V_{IH} | $I_{OH} = -50 \mu\text{A}$ | 2.0 | 1.9 | 2.0 | — | 1.9 | — | V |
| | | | | | 3.0 | 2.9 | 3.0 | — | 2.9 | — | V |
| | | | | | 4.5 | 4.4 | 4.5 | — | 4.4 | — | V |
| | | | | $I_{OH} = -4 \text{ mA}$ | 3.0 | 2.58 | — | — | 2.48 | — | V |
| | | | | | 4.5 | 3.94 | — | — | 3.80 | — | V |
| | | | | | | $I_{OH} = -8 \text{ mA}$ | 4.5 | 3.94 | — | — | 3.80 |
| | "L" level | V_{OL} | $V_{IN} = V_{IH}$ | $I_{OL} = 50 \mu\text{A}$ | 2.0 | — | 0 | 0.1 | — | 0.1 | V |
| | | | | | 3.0 | — | 0 | 0.1 | — | 0.1 | V |
| | | | | 4.5 | — | 0 | 0.1 | — | 0.1 | V | |
| | | | | | $I_{OL} = 4 \text{ mA}$ | 3.0 | — | — | 0.36 | — | 0.44 |
| $I_{OL} = 8 \text{ mA}$ | 4.5 | — | — | 0.36 | — | 0.44 | V | | | | |
| Input current | I_{IN} | $V_{IN} = 5.5 \text{ V}$ or GND | 0 to 5.5 | — | — | ± 0.1 | — | ± 1.0 | μA | | |
| Current consumption | I_{CC} | $V_{IN} = V_{CC}$ or GND | 5.5 | — | — | 1.0 | — | 10.0 | μA | | |

■ AC Electrical Characteristics

(Input $t_R = t_F = 3$ ns unless otherwise specified)

| Item | Symbol | Measurement Conditions | | Ta = 25°C | | | Ta = -40 to 85°C | | Unit |
|---------------------------------|-------------------------------|------------------------|---------------------|-----------|------|------|------------------|------|------|
| | | V _{CC} (V) | C _L (pF) | Min. | Typ. | Max. | Min. | Max. | |
| Propagation delay time | t_{PLH} , t_{PHL} | 3.3±0.3 | 15 | — | 5.5 | 7.9 | 1.0 | 9.5 | ns |
| | | | 50 | — | 10.0 | 14.0 | 1.0 | 15.0 | ns |
| | | 5.0±0.5 | 15 | — | 3.7 | 5.5 | 1.0 | 6.5 | ns |
| | | | 50 | — | 6.1 | 8.5 | 1.0 | 9.0 | ns |
| Input capacitance | C _{IN} | — | — | 4 | 10 | — | 10 | pF | |
| Equivalent internal capacitance | C _{PD} ^{*1} | — | — | 14 | — | — | — | pF | |

*1. C_{PD} is the no-load equivalent capacitance inside the circuitry. Refer to the measurement circuit shown below. Current consumption is averaged by the following equation.

$$I_{CC(opr)} = C_{PD} \times V_{CC} \times fin + I_{CC}$$

Measurement Circuit

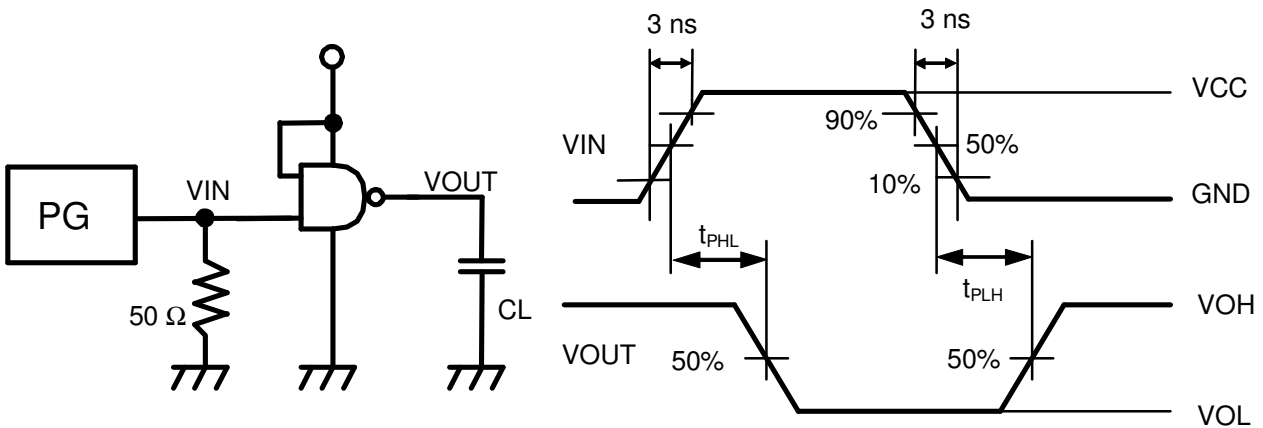

Remark No-load output during measurement of current consumption.

■ Input Pin Equivalent Circuit

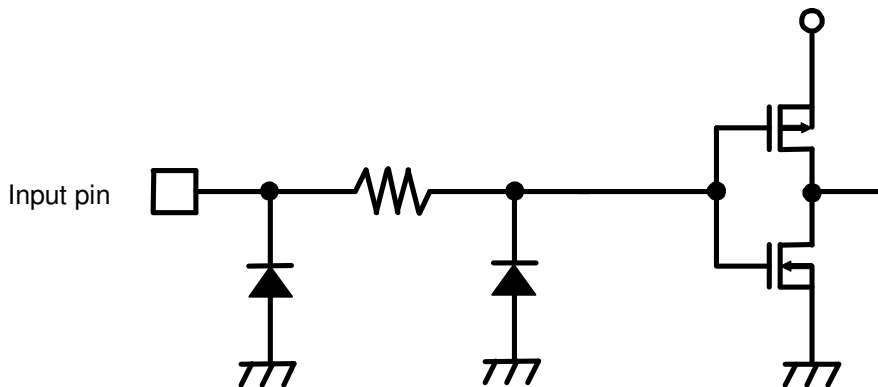

The S-75V02ANC is a single 2-input NOR gate fabricated by utilizing advanced silicon-gate CMOS technology which provides the inherent benefit of CMOS low power consumption to achieve ultra high speed operation correspond to LSTTL IC's.

All gates of the internal circuitry have buffered outputs to ensure high noise immunity and output stability.

Input voltage is allowed to be applied even if power voltage is not supplied because no diode is inserted between an input pin and V_{CC} .

This allows for interfaces between power supplies of different voltage, output level conversion from 5 V to 3 V and battery backup applications.

■ Features

- Wide power supply range: 2 V to 5.5 V
- Low current consumption: 1.0 μ A max. (at 5.5 V, 25°C)
- Typical propagation delay: $t_{PD} = 3.6$ ns (at 5 V)
- High noise immunity: $V_{NIH} = V_{NIL} = 28\% V_{CC}$ min.
- Power down protection: All pins
- Lead-free

■ Applications

- Personal computers, peripherals
- Cellular phones
- Cameras
- Games

■ Package

- SC-88A

■ Pin Configuration

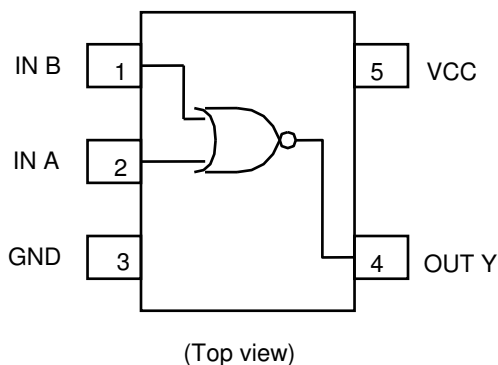

■ Marking Specification

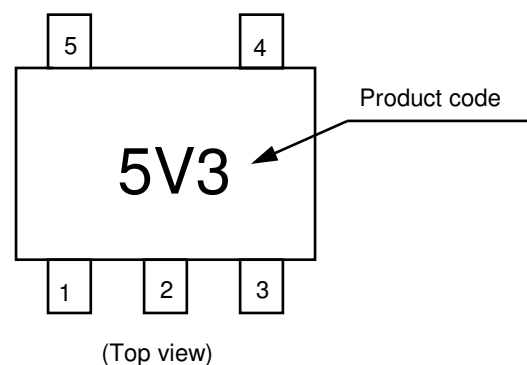

■ Logic Diagram

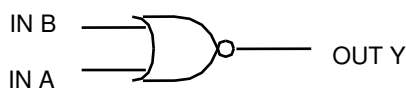

True values

| A | B | Y |
|---|---|---|
| L | L | H |
| L | H | L |
| H | L | L |
| H | H | L |

■ Product Name Structure

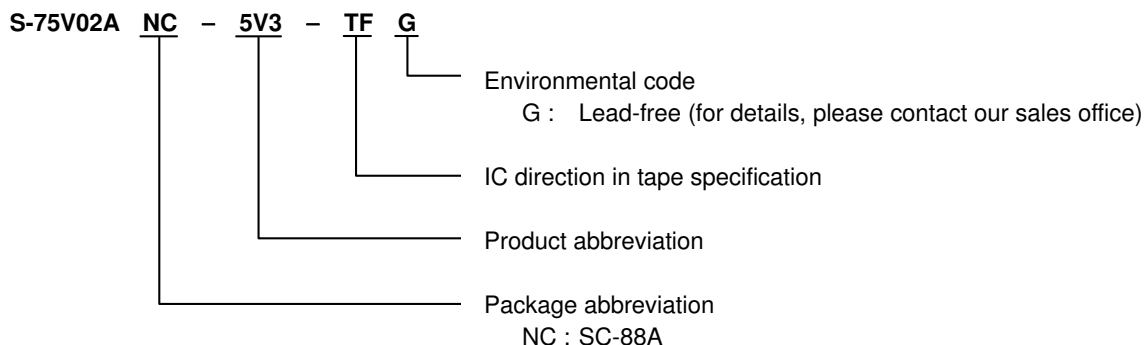

■ Absolute Maximum Ratings

(Ta = 25°C unless otherwise specified)

| Item | Symbol | Absolute Maximum Ratings | Unit |
|--------------------------------|-----------|---------------------------------|------|
| Power supply voltage | V_{CC} | -0.5 to +7.0 | V |
| Input voltage | V_{IN} | -0.5 to +7.0 | V |
| Output voltage | V_{OUT} | -0.5 to $V_{CC} + 0.5$ | V |
| Input parasitic diode current | I_{IK} | -20 | mA |
| Output parasitic diode current | I_{OK} | ±20 | mA |
| Output current | I_{OUT} | ±25 | mA |
| V_{CC} /GND current | I_{CC} | ±50 | mA |
| Power dissipation | P_D | 200 (When not mounted on board) | mW |
| | | 350*1 | mW |
| Operating ambient temperature | T_{opr} | -40 to +85 | °C |
| Storage temperature | T_{stg} | -65 to +150 | °C |
| Lead temperature (10 s) | T_L | 260 | °C |

*1. When mounted on board
[Mounted board]

- (1) Board size : 114.3 mm × 76.2 mm × t1.6 mm
- (2) Board name : JEDEC STANDARD51-7

Caution The absolute maximum ratings are rated values exceeding which the product could suffer physical damage. These values must therefore not be exceeded under any conditions.

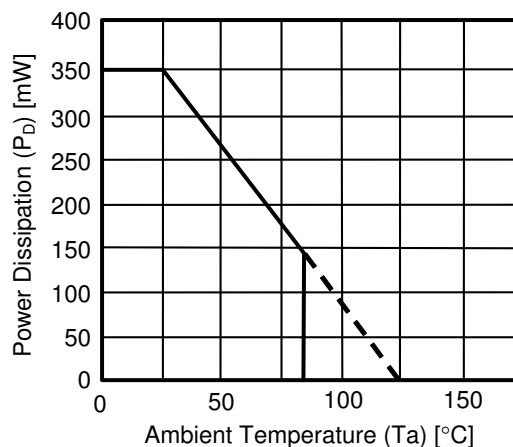

Power Dissipation of Package (When Mounted on Board)

■ Recommended Operating Conditions

| Item | Symbol | Standard | Unit |
|------------------------|------------|--------------------------------------|------|
| Power voltage | V_{CC} | 2 to 5.5 | V |
| Input voltage | V_{IN} | 0 to 5.5 | V |
| Output voltage | V_{OUT} | 0 to V_{CC} | V |
| Input rise / fall time | t_R, t_F | 0 to 100 ($V_{CC} = 3.3 \pm 0.3$ V) | ns |
| | | 0 to 20 ($V_{CC} = 5 \pm 0.5$ V) | ns |

■ DC Electrical Characteristics

| Item | Symbol | Conditions | $T_a = 25^\circ\text{C}$ | | | $T_a = -40$ to 85°C | | Unit | | | |
|---------------------|-----------|--------------------------|----------------------------------|----------------------------|---------------------|-----------------------------------|---------------------|---------------------|---------------------|------|---|
| | | | V_{CC} | Min. | Typ. | Max. | Min. | | Max. | | |
| Input voltage | "H" level | V_{IH} | — | 2.0 | 1.5 | — | — | 1.5 | — | V | |
| | | | | 3 to 5.5 | $V_{CC} \times 0.7$ | — | — | $V_{CC} \times 0.7$ | — | V | |
| | "L" level | V_{IL} | — | 2.0 | — | — | 0.5 | — | 0.5 | V | |
| | | | | 3 to 5.5 | — | — | $V_{CC} \times 0.3$ | — | $V_{CC} \times 0.3$ | V | |
| Output voltage | "H" level | V_{OH} | $V_{IN} = V_{IL}$ | $I_{OH} = -50 \mu\text{A}$ | 2.0 | 1.9 | 2.0 | — | 1.9 | — | V |
| | | | | | 3.0 | 2.9 | 3.0 | — | 2.9 | — | V |
| | | | | | 4.5 | 4.4 | 4.5 | — | 4.4 | — | V |
| | | | | $I_{OH} = -4 \text{ mA}$ | 3.0 | 2.58 | — | — | 2.48 | — | V |
| | | | | | 4.5 | 3.94 | — | — | 3.80 | — | V |
| | | | | | | | | | | | |
| | "L" level | V_{OL} | $V_{IN} = V_{IH}$ or V_{IL} | $I_{OL} = 50 \mu\text{A}$ | 2.0 | — | 0 | 0.1 | — | 0.1 | V |
| | | | | | 3.0 | — | 0 | 0.1 | — | 0.1 | V |
| | | | | | 4.5 | — | 0 | 0.1 | — | 0.1 | V |
| | | | | | 3.0 | — | — | 0.36 | — | 0.44 | V |
| | | | | | | | | | | | |
| 4.5 | — | — | 0.36 | — | 0.44 | V | | | | | |
| | | | | | | | | | | | |
| Input current | I_{IN} | $V_{IN} = 5.5$ V or GND | 0 to 5.5 | — | — | ± 0.1 | — | ± 1.0 | μA | | |
| Current consumption | I_{CC} | $V_{IN} = V_{CC}$ or GND | 5.5 | — | — | 1.0 | — | 10.0 | μA | | |

■ AC Electrical Characteristics

(Input $t_R = t_F = 3$ ns unless otherwise specified)

| Item | Symbol | Measurement Conditions | | Ta = 25°C | | | Ta = -40 to 85°C | | Unit |
|---------------------------------|-------------------------------|------------------------|---------------------|-----------|------|------|------------------|------|------|
| | | V _{CC} (V) | C _L (pF) | Min. | Typ. | Max. | Min. | Max. | |
| Propagation delay time | t_{PLH} , t_{PHL} | 3.3±0.3 | 15 | — | 5.6 | 7.9 | 1.0 | 9.5 | ns |
| | | | 50 | — | 10.0 | 14.0 | 1.0 | 15.0 | ns |
| | | 5.0±0.5 | 15 | — | 3.6 | 5.5 | 1.0 | 6.5 | ns |
| | | | 50 | — | 5.7 | 8.0 | 1.0 | 9.0 | ns |
| Input capacitance | C _{IN} | — | — | 4 | 10 | — | 10 | pF | |
| Equivalent internal capacitance | C _{PD} ^{*1} | — | — | 15 | — | — | — | pF | |

*1. C_{PD} is the no-load equivalent capacitance inside the circuitry. Refer to the measurement circuit shown below. Current consumption is averaged by the following equation.

$$I_{CC(opr)} = C_{PD} \times V_{CC} \times fin + I_{CC}$$

Measurement Circuit

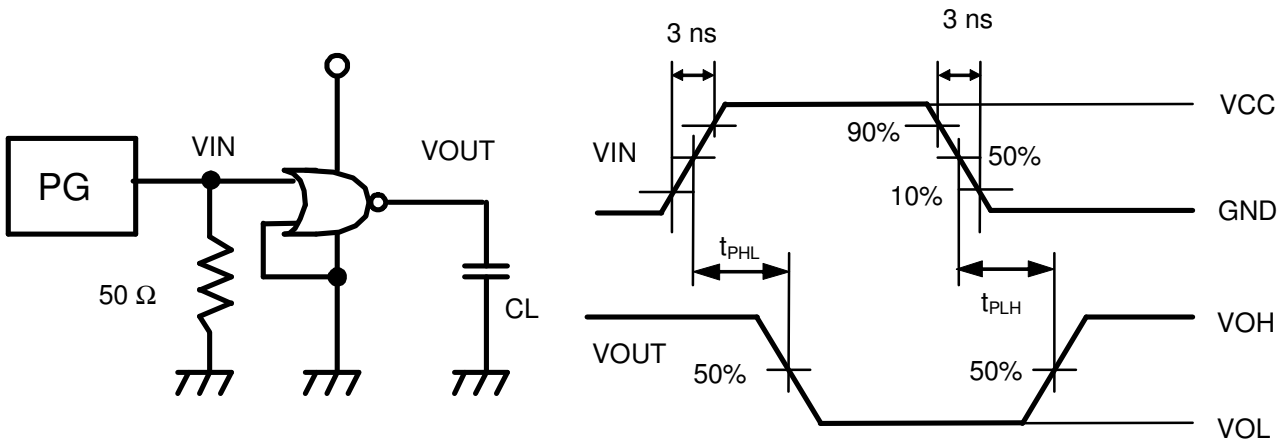

Remark No-load output during measurement of current consumption.

■ Input Pin Equivalent Circuit

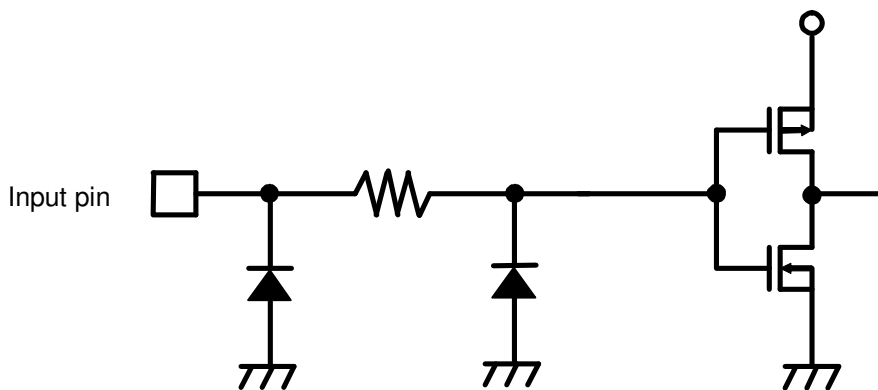

The S-75V04ANC is a INVERTER fabricated by utilizing advanced silicon-gate CMOS technology which provides the inherent benefit of CMOS low power consumption to achieve ultra high speed operation correspond to LSTTL IC's.

The special purpose unbuffered circuit design is suitable for a wide variety of linear circuits.

Input voltage is allowed to be applied even if power voltage is not supplied because no diode is inserted between an input pin and V_{CC} .

This allows for interfaces between power supplies of different voltage, output level conversion from 5 V to 3 V and battery backup applications.

■ Features

- Wide power supply range: 2 V to 5.5 V
- Low current consumption: 1.0 μ A max. (at 5.5 V, 25°C)
- Typical propagation delay: $t_{PD} = 3.8$ ns (at 5 V)
- High noise immunity: $V_{NIH} = V_{NIL} = 28\% V_{CC}$ min.
- Power down protection: All pins
- Lead-free

■ Applications

- Personal computers, peripherals
- Cellular phones
- Cameras
- Games

■ Package

- SC-88A

■ Pin Configuration

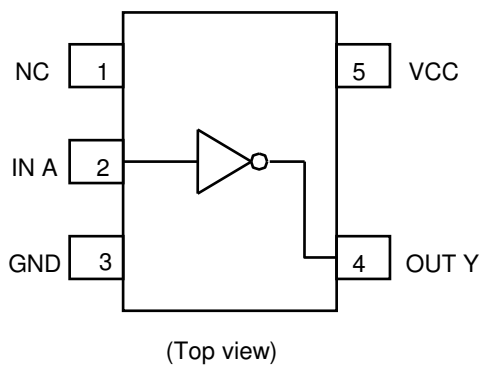

■ Marking Specification

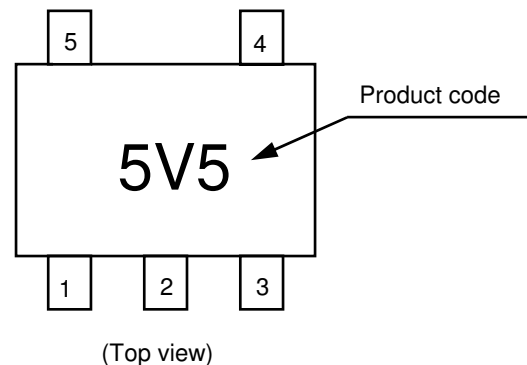

■ Logic Diagram

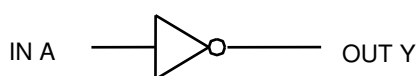

True values

| A | Y |
|---|---|
| L | H |
| H | L |

■ **Product Name Structure**

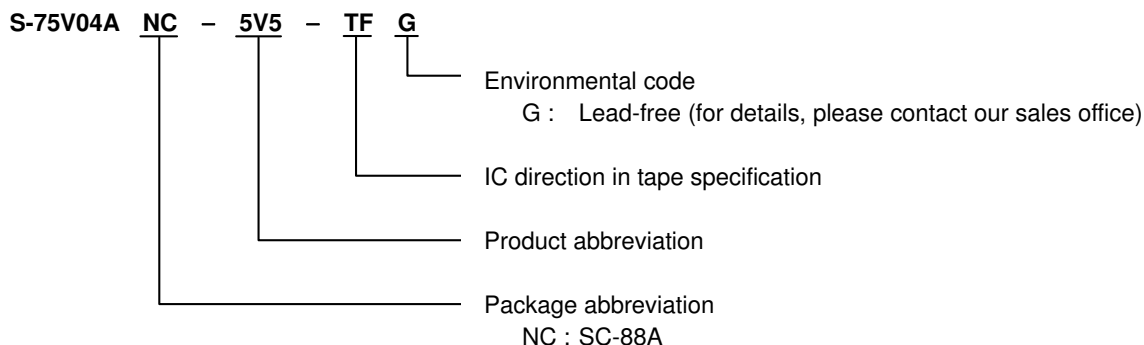

■ **Absolute Maximum Ratings**

(Ta = 25°C unless otherwise specified)

| Item | Symbol | Absolute Maximum Ratings | Unit |
|--------------------------------|-----------|---------------------------------|------|
| Power supply voltage | V_{CC} | -0.5 to +7.0 | V |
| Input voltage | V_{IN} | -0.5 to +7.0 | V |
| Output voltage | V_{OUT} | -0.5 to $V_{CC} + 0.5$ | V |
| Input parasitic diode current | I_{IK} | -20 | mA |
| Output parasitic diode current | I_{OK} | ±20 | mA |
| Output current | I_{OUT} | ±25 | mA |
| V_{CC}/GND current | I_{CC} | ±50 | mA |
| Power dissipation | P_D | 200 (When not mounted on board) | mW |
| | | 350 ^{*1} | mW |
| Operating ambient temperature | T_{opr} | -40 to +85 | °C |
| Storage temperature | T_{stg} | -65 to +150 | °C |
| Lead temperature (10 s) | T_L | 260 | °C |

*1. When mounted on board

[Mounted board]

(1) Board size : 114.3 mm × 76.2 mm × t1.6 mm

(2) Board name : JEDEC STANDARD51-7

Caution The absolute maximum ratings are rated values exceeding which the product could suffer physical damage. These values must therefore not be exceeded under any conditions.

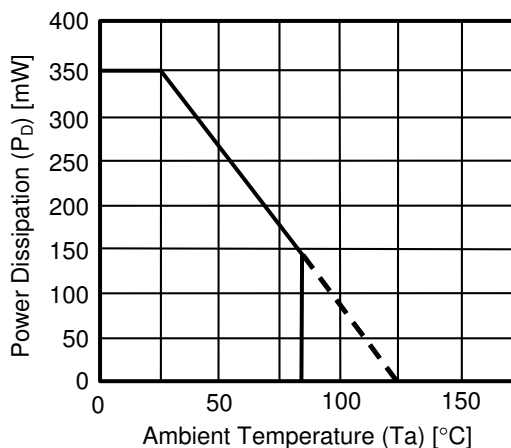

Power Dissipation of Package (When Mounted on Board)

■ Recommended Operating Conditions

| Item | Symbol | Standard | Unit |
|------------------------|------------|--------------------------------------|------|
| Power voltage | V_{CC} | 2 to 5.5 | V |
| Input voltage | V_{IN} | 0 to 5.5 | V |
| Output voltage | V_{OUT} | 0 to V_{CC} | V |
| Input rise / fall time | t_R, t_F | 0 to 100 ($V_{CC} = 3.3 \pm 0.3$ V) | ns |
| | | 0 to 20 ($V_{CC} = 5 \pm 0.5$ V) | ns |

■ DC Electrical Characteristics

| Item | Symbol | Conditions | $T_a = 25^\circ\text{C}$ | | | $T_a = -40$ to 85°C | | Unit | | | | |
|---------------------|-----------|---------------------------------|--------------------------|----------------------------|--------------------------|-----------------------------------|---------------------|---------------------|---------------------|------|------|---|
| | | | V_{CC} | Min. | Typ. | Max. | Min. | | Max. | | | |
| Input voltage | "H" level | V_{IH} | — | 2.0 | 1.5 | — | — | 1.5 | — | V | | |
| | | | | 3 to 5.5 | $V_{CC} \times 0.7$ | — | — | $V_{CC} \times 0.7$ | — | V | | |
| | "L" level | V_{IL} | — | 2.0 | — | — | 0.5 | — | 0.5 | V | | |
| | | | | 3 to 5.5 | — | — | $V_{CC} \times 0.3$ | — | $V_{CC} \times 0.3$ | V | | |
| Output voltage | "H" level | V_{OH} | $V_{IN} = V_{IL}$ | $I_{OH} = -50 \mu\text{A}$ | 2.0 | 1.9 | 2.0 | — | 1.9 | — | V | |
| | | | | | 3.0 | 2.9 | 3.0 | — | 2.9 | — | V | |
| | | | | | 4.5 | 4.4 | 4.5 | — | 4.4 | — | V | |
| | | | | $I_{OH} = -4 \text{ mA}$ | 3.0 | 2.58 | — | — | 2.48 | — | V | |
| | | | | | $I_{OH} = -8 \text{ mA}$ | 4.5 | 3.94 | — | — | 3.80 | — | V |
| | | | | | | — | — | — | — | — | — | V |
| | "L" level | V_{OL} | $V_{IN} = V_{IH}$ | $I_{OL} = 50 \mu\text{A}$ | 2.0 | — | 0 | 0.1 | — | 0.1 | V | |
| | | | | | 3.0 | — | 0 | 0.1 | — | 0.1 | V | |
| | | | | | 4.5 | — | 0 | 0.1 | — | 0.1 | V | |
| | | | | | $I_{OL} = 4 \text{ mA}$ | 3.0 | — | — | 0.36 | — | 0.44 | V |
| 4.5 | — | — | 0.36 | — | | 0.44 | V | | | | | |
| Input current | I_{IN} | $V_{IN} = 5.5 \text{ V}$ or GND | 0 to 5.5 | — | — | ± 0.1 | — | ± 1.0 | μA | | | |
| Current consumption | I_{CC} | $V_{IN} = V_{CC}$ or GND | 5.5 | — | — | 1.0 | — | 10.0 | μA | | | |

■ AC Electrical Characteristics

(Input $t_R = t_F = 3$ ns unless otherwise specified)

| Item | Symbol | Measurement Conditions | | Ta = 25°C | | | Ta = -40 to 85°C | | Unit | |
|---------------------------------|-------------------------------|------------------------|---------------------|-----------|------|------|------------------|------|------|----|
| | | V _{CC} (V) | C _L (pF) | Min. | Typ. | Max. | Min. | Max. | | |
| Propagation delay time | t_{PLH} , t_{PHL} | — | 3.3±0.3 | 15 | — | 5.0 | 7.1 | 1.0 | 8.5 | ns |
| | | | | 50 | — | 9.6 | 13.5 | 1.0 | 14.5 | ns |
| | | | 5.0±0.5 | 15 | — | 3.8 | 5.5 | 1.0 | 6.5 | ns |
| | | | | 50 | — | 5.7 | 8.0 | 1.0 | 9.0 | ns |
| Input capacitance | C _{IN} | — | — | — | 4 | 10 | — | 10 | pF | |
| Equivalent internal capacitance | C _{PD} ^{*1} | — | — | — | 13 | — | — | — | pF | |

*1. C_{PD} is the no-load equivalent capacitance inside the circuitry. Refer to the measurement circuit shown below. Current consumption is averaged by the following equation.

$$I_{CC(opr)} = C_{PD} \times V_{CC} \times fin + I_{CC}$$

Measurement Circuit

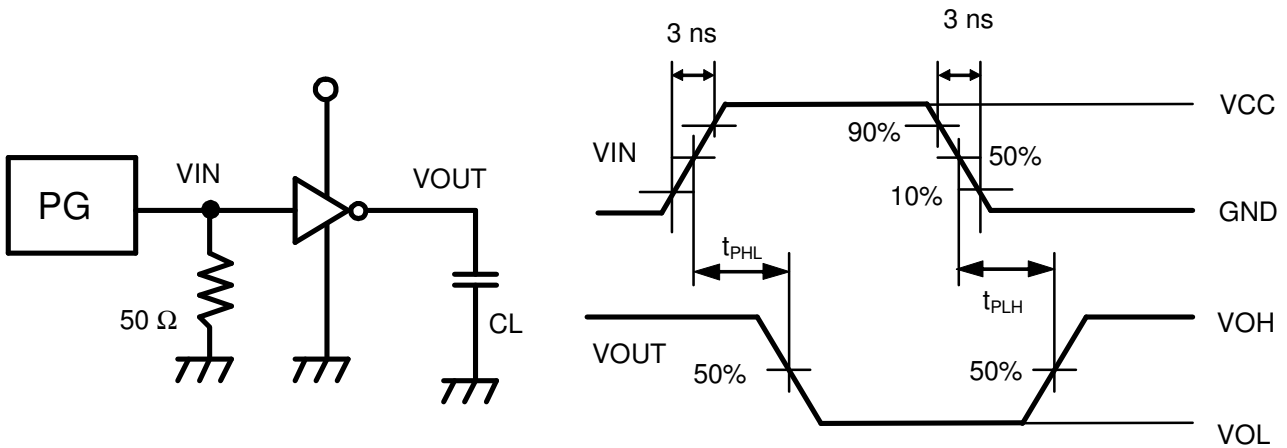

Remark No-load output during measurement of current consumption.

■ Input Pin Equivalent Circuit

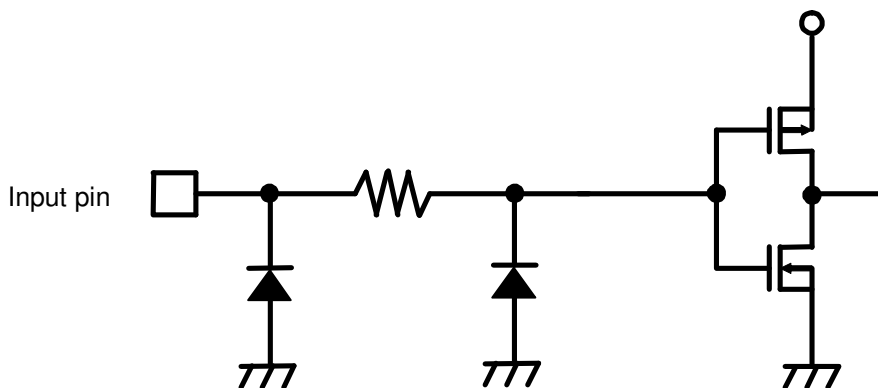

The S-75VU04ANC is an inverter fabricated by utilizing advanced silicon-gate CMOS technology which provides the inherent benefit of CMOS low power consumption to achieve ultra high speed operation correspond to LSTTL IC's.

The special purpose unbuffered circuit design is suitable for a wide variety of linear circuits.

Input voltage is allowed to be applied even if power voltage is not supplied because no diode is inserted between an input pin and V_{CC} .

This allows for interfaces between power supplies of different voltage, output level conversion from 5 V to 3 V and battery backup applications.

■ Features

- Wide power supply range: 2 V to 5.5 V
- Low current consumption: 1.0 μ A max. (at 5.5 V, 25°C)
- Typical propagation delay: $t_{PD} = 3.5$ ns (at 5 V)
- High noise immunity: $V_{NIH} = V_{NIL} = 10\%$ V_{CC} min.
- Power down protection: All pins
- Lead-free

■ Applications

- Personal computers, peripherals
- Cellular phones
- Cameras
- Games

■ Package

- SC-88A

■ Pin Configuration

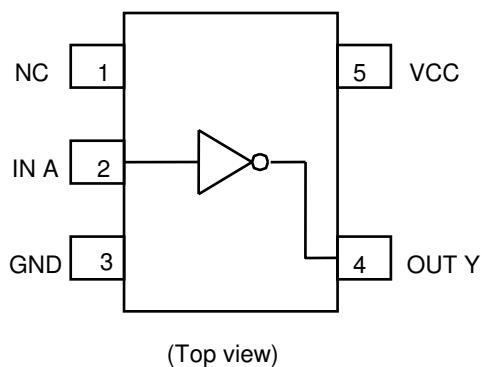

■ Marking Specification

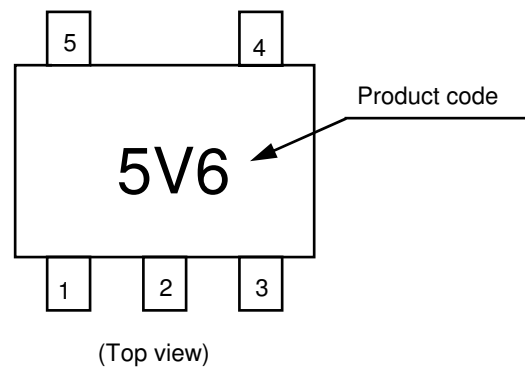

■ Logic Diagram

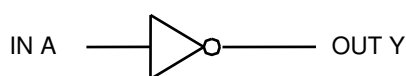

True values

| A | Y |
|---|---|
| L | H |
| H | L |

■ Product Name Structure

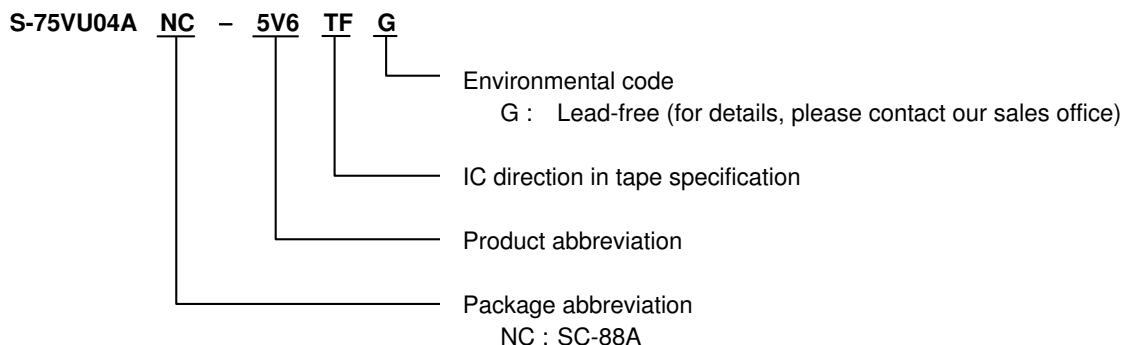

■ Absolute Maximum Ratings

(Ta = 25°C unless otherwise specified)

| Item | Symbol | Absolute Maximum Ratings | Unit |
|--------------------------------|-----------|---------------------------------|------|
| Power supply voltage | V_{CC} | -0.5 to +7.0 | V |
| Input voltage | V_{IN} | -0.5 to +7.0 | V |
| Output voltage | V_{OUT} | -0.5 to $V_{CC} + 0.5$ | V |
| Input parasitic diode current | I_{IK} | -20 | mA |
| Output parasitic diode current | I_{OK} | ±20 | mA |
| Output current | I_{OUT} | ±25 | mA |
| V_{CC} /GND current | I_{CC} | ±50 | mA |
| Power dissipation | P_D | 200 (When not mounted on board) | mW |
| | | 350*1 | mW |
| Operating ambient temperature | T_{opr} | -40 to +85 | °C |
| Storage temperature | T_{stg} | -65 to +150 | °C |
| Lead temperature (10 s) | T_L | 260 | °C |

*1. When mounted on board
[Mounted board]

- (1) Board size : 114.3 mm × 76.2 mm × t1.6 mm
- (2) Board name : JEDEC STANDARD51-7

Caution The absolute maximum ratings are rated values exceeding which the product could suffer physical damage. These values must therefore not be exceeded under any conditions.

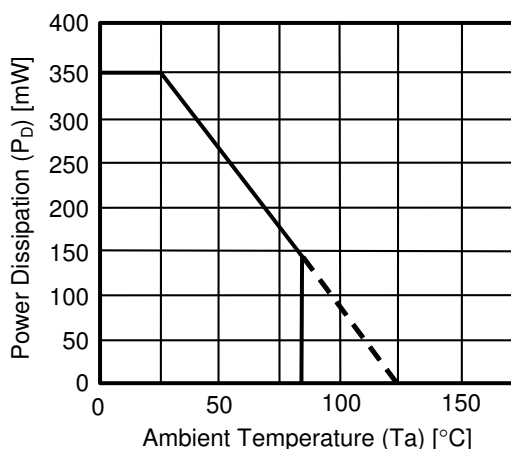

Power Dissipation of Package (When Mounted on Board)

■ Recommended Operating Conditions

| Item | Symbol | Standard | Unit |
|----------------|-----------|---------------|------|
| Power voltage | V_{CC} | 2 to 5.5 | V |
| Input voltage | V_{IN} | 0 to 5.5 | V |
| Output voltage | V_{OUT} | 0 to V_{CC} | V |

■ DC Electrical Characteristics

| Item | Symbol | Conditions | Ta = 25°C | | | Ta = -40 to 85°C | | Unit | | | | |
|---------------------|-----------|----------------------------------|--------------------|--------------------------|---------------------|--------------------------|---------------------|---------------------|---------------------|------|------|---|
| | | | V_{CC} | Min. | Typ. | Max. | Min. | | Max. | | | |
| Input voltage | "H" level | V_{IH} | $V_{OUT} = V_{OL}$ | 2.0 | 1.7 | — | — | 1.7 | — | V | | |
| | | | | 3 to 5.5 | $V_{CC} \times 0.8$ | — | — | $V_{CC} \times 0.8$ | — | V | | |
| | "L" level | V_{IL} | $V_{OUT} = V_{OH}$ | 2.0 | — | — | 0.3 | — | 0.3 | V | | |
| | | | | 3 to 5.5 | — | — | $V_{CC} \times 0.2$ | — | $V_{CC} \times 0.2$ | V | | |
| Output voltage | "H" level | V_{OH} | $V_{IN} = V_{IL}$ | $I_{OH} = -50 \mu A$ | 2.0 | 1.8 | 2.0 | — | 1.8 | — | V | |
| | | | | | 3.0 | 2.7 | 3.0 | — | 2.7 | — | V | |
| | | | | | 4.5 | 4.0 | 4.5 | — | 4.0 | — | V | |
| | | V_{OH} | $V_{IN} = GND$ | $I_{OH} = -4 \text{ mA}$ | 3.0 | 2.58 | — | — | 2.48 | — | V | |
| | | | | | 4.5 | $I_{OH} = -8 \text{ mA}$ | 3.94 | — | — | 3.80 | — | V |
| | | | | | | | — | — | — | — | — | V |
| | "L" level | V_{OL} | $V_{IN} = V_{IH}$ | $I_{OL} = 50 \mu A$ | 2.0 | — | 0 | 0.2 | — | 0.2 | V | |
| | | | | | 3.0 | — | 0 | 0.3 | — | 0.3 | V | |
| | | | 4.5 | $I_{OL} = 4 \text{ mA}$ | — | — | 0 | 0.5 | — | 0.5 | V | |
| | | | | | 4.5 | $I_{OL} = 8 \text{ mA}$ | — | — | 0.36 | — | 0.44 | V |
| — | — | 0.36 | — | 0.44 | | | V | | | | | |
| Input current | I_{IN} | $V_{IN} = 5.5 \text{ V or GND}$ | 0 to 5.5 | — | — | ± 0.1 | — | ± 1.0 | μA | | | |
| Current consumption | I_{CC} | $V_{IN} = V_{CC} \text{ or GND}$ | 5.5 | — | — | 1.0 | — | 10.0 | μA | | | |

■ AC Electrical Characteristics

(Input $t_R = t_F = 3$ ns unless otherwise specified)

| Item | Symbol | Measurement Conditions | | Ta = 25°C | | | Ta = -40 to 85°C | | Unit |
|---------------------------------|--|------------------------|---------------------|-----------|------|------|------------------|------|------|
| | | V _{CC} (V) | C _L (pF) | Min. | Typ. | Max. | Min. | Max. | |
| Propagation delay time | t _{PLH} , t _{PHL} | 3.3±0.3 | 15 | — | 5.0 | 8.9 | 1.0 | 10.5 | ns |
| | | | 50 | — | 8.9 | 12.5 | 1.0 | 13.5 | ns |
| | | 5.0±0.5 | 15 | — | 3.5 | 5.5 | 1.0 | 6.5 | ns |
| | | | 50 | — | 5.4 | 7.5 | 1.0 | 8.0 | ns |
| Input capacitance | C _{IN} | — | — | 5 | 10 | — | 10 | pF | |
| Equivalent internal capacitance | C _{PD} ^{*1} | — | — | 6 | — | — | — | pF | |

*1. C_{PD} is the no-load equivalent capacitance inside the circuitry. Refer to the measurement circuit shown below. Current consumption is averaged by the following equation.

$$I_{CC(opr)} = C_{PD} \times V_{CC} \times fin + I_{CC}$$

Measurement Circuit

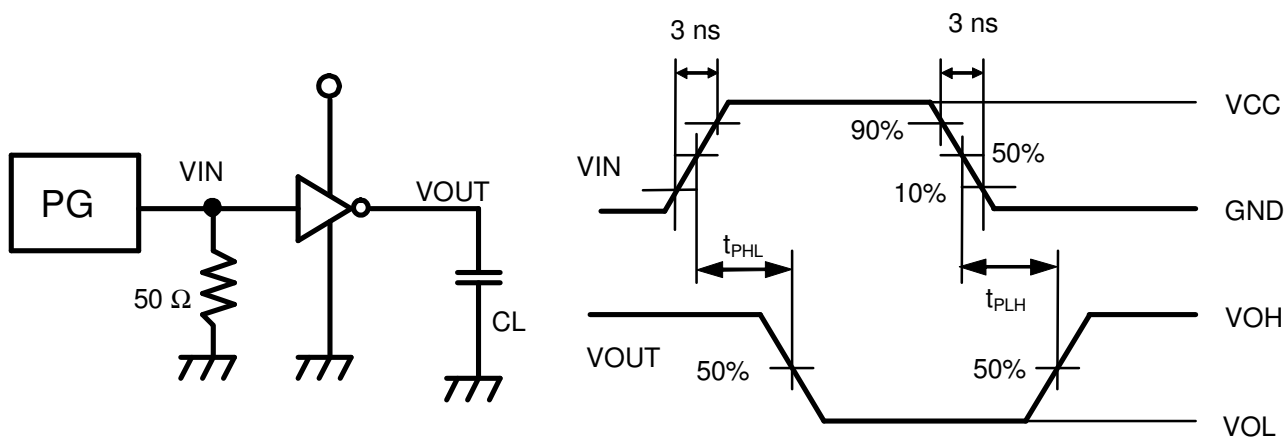

Remark No-load output during measurement of current consumption.

■ Input Pin Equivalent Circuit

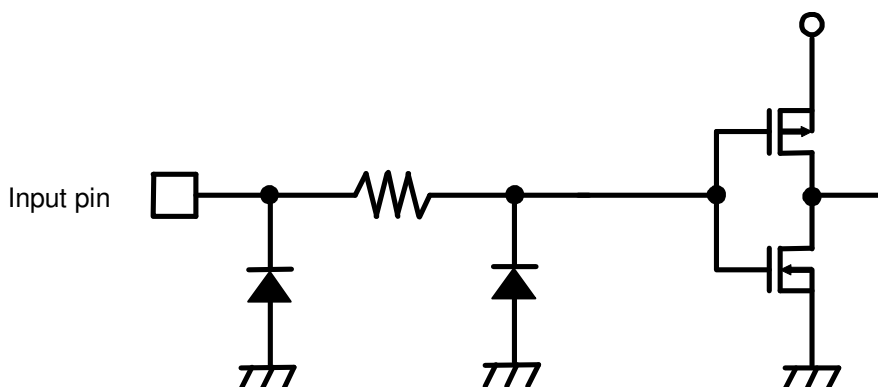

The S-75V08ANC is a Single 2-Input AND Gate fabricated by utilizing advanced silicon-gate CMOS technology which provides the inherent benefit of CMOS low power consumption to achieve ultra high speed operation correspond to LSTTL IC's.

All gates of the internal circuitry have buffered outputs to ensure high noise immunity and output stability.

Input voltage is allowed to be applied even if power voltage is not supplied because no diode is inserted between an input pin and V_{CC} .

This allows for interfaces between power supplies of different voltage, output level conversion from 5 V to 3 V and battery backup applications.

■ Features

- Wide power supply range: 2 V to 5.5 V
- Low current consumption: 1.0 μ A max. (at 5.5 V, 25°C)
- Typical propagation delay: $t_{PD} = 4.3$ ns (at 5 V)
- High noise immunity: $V_{NIH} = V_{NIL} = 28\% V_{CC}$ min.
- Power down protection: All pins
- Lead-free

■ Applications

- Personal computers, peripherals
- Cellular phones
- Cameras
- Games

■ Package

- SC-88A

■ Pin Configuration

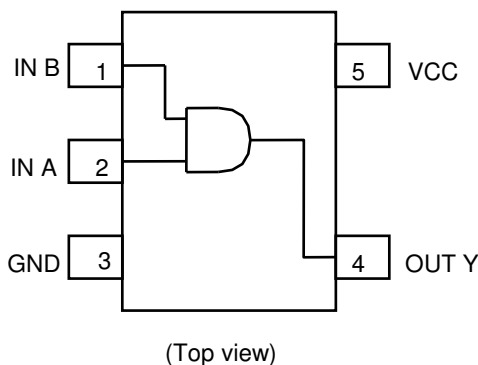

■ Marking Specification

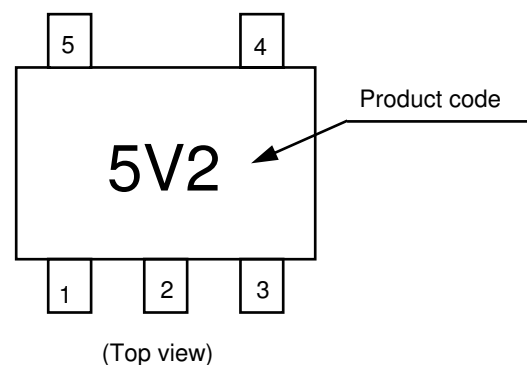

■ Logic Diagram

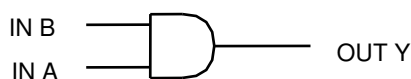

True values

| A | B | Y |
|---|---|---|
| L | L | L |
| L | H | L |
| H | L | L |
| H | H | H |

■ Product Name Structure

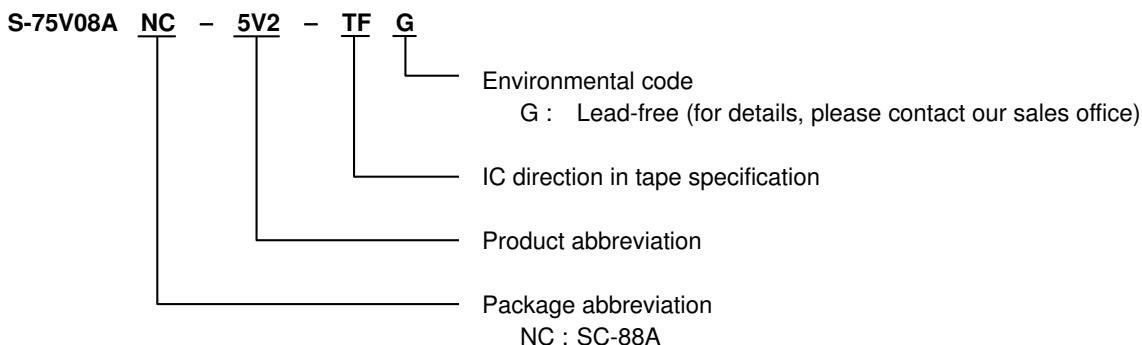

■ Absolute Maximum Ratings

(Ta = 25°C unless otherwise specified)

| Item | Symbol | Absolute Maximum Ratings | Unit |
|--------------------------------|-----------|---------------------------------|------|
| Power supply voltage | V_{CC} | -0.5 to +7.0 | V |
| Input voltage | V_{IN} | -0.5 to +7.0 | V |
| Output voltage | V_{OUT} | -0.5 to $V_{CC} + 0.5$ | V |
| Input parasitic diode current | I_{IK} | -20 | mA |
| Output parasitic diode current | I_{OK} | ±20 | mA |
| Output current | I_{OUT} | ±25 | mA |
| V_{CC}/GND current | I_{CC} | ±50 | mA |
| Power dissipation | P_D | 200 (When not mounted on board) | mW |
| | | 350*1 | mW |
| Operating ambient temperature | T_{opr} | -40 to +85 | °C |
| Storage temperature | T_{stg} | -65 to +150 | °C |
| Lead temperature (10 s) | T_L | 260 | °C |

*1. When mounted on board
[Mounted board]

- (1) Board size : 114.3 mm × 76.2 mm × t1.6 mm
- (2) Board name : JEDEC STANDARD51-7

Caution The absolute maximum ratings are rated values exceeding which the product could suffer physical damage. These values must therefore not be exceeded under any conditions.

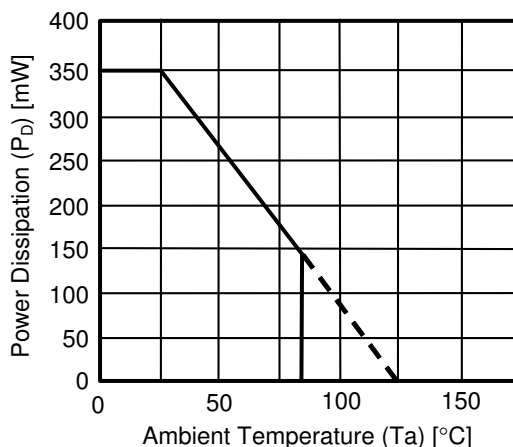

Power Dissipation of Package (When Mounted on Board)

■ Recommended Operating Conditions

| Item | Symbol | Standard | Unit |
|------------------------|------------|--------------------------------------|------|
| Power voltage | V_{CC} | 2 to 5.5 | V |
| Input voltage | V_{IN} | 0 to 5.5 | V |
| Output voltage | V_{OUT} | 0 to V_{CC} | V |
| Input rise / fall time | t_R, t_F | 0 to 100 ($V_{CC} = 3.3 \pm 0.3$ V) | ns |
| | | 0 to 20 ($V_{CC} = 5 \pm 0.5$ V) | ns |

■ DC Electrical Characteristics

| Item | Symbol | Conditions | $T_a = 25^\circ\text{C}$ | | | $T_a = -40$ to 85°C | | Unit | | | | |
|---------------------|-----------|---------------------------------|----------------------------------|----------------------------|--------------------------|-----------------------------------|---------------------|---------------------|---------------------|------|------|---|
| | | | V_{CC} | Min. | Typ. | Max. | Min. | | Max. | | | |
| Input voltage | "H" level | V_{IH} | — | 2.0 | 1.5 | — | — | 1.5 | — | V | | |
| | | | | 3 to 5.5 | $V_{CC} \times 0.7$ | — | — | $V_{CC} \times 0.7$ | — | V | | |
| | "L" level | V_{IL} | — | 2.0 | — | — | 0.5 | — | 0.5 | V | | |
| | | | | 3 to 5.5 | — | — | $V_{CC} \times 0.3$ | — | $V_{CC} \times 0.3$ | V | | |
| Output voltage | "H" level | V_{OH} | $V_{IN} = V_{IH}$ | $I_{OH} = -50 \mu\text{A}$ | 2.0 | 1.9 | 2.0 | — | 1.9 | — | V | |
| | | | | | 3.0 | 2.9 | 3.0 | — | 2.9 | — | V | |
| | | | | | 4.5 | 4.4 | 4.5 | — | 4.4 | — | V | |
| | | | | $I_{OH} = -4 \text{ mA}$ | 3.0 | 2.58 | — | — | 2.48 | — | V | |
| | | | | | $I_{OH} = -8 \text{ mA}$ | 4.5 | 3.94 | — | — | 3.80 | — | V |
| | | | | | | — | — | — | — | — | — | V |
| | "L" level | V_{OL} | $V_{IN} = V_{IH}$ or V_{IL} | $I_{OL} = 50 \mu\text{A}$ | 2.0 | — | 0 | 0.1 | — | 0.1 | V | |
| | | | | | 3.0 | — | 0 | 0.1 | — | 0.1 | V | |
| | | | | | 4.5 | — | 0 | 0.1 | — | 0.1 | V | |
| | | | | | $I_{OL} = 4 \text{ mA}$ | 3.0 | — | — | 0.36 | — | 0.44 | V |
| 4.5 | — | — | 0.36 | — | | 0.44 | V | | | | | |
| Input current | I_{IN} | $V_{IN} = 5.5 \text{ V}$ or GND | 0 to 5.5 | — | — | ± 0.1 | — | ± 1.0 | μA | | | |
| Current consumption | I_{CC} | $V_{IN} = V_{CC}$ or GND | 5.5 | — | — | 1.0 | — | 10.0 | μA | | | |

■ AC Electrical Characteristics

(Input $t_R = t_F = 3$ ns unless otherwise specified)

| Item | Symbol | Measurement Conditions | | Ta = 25°C | | | Ta = -40 to 85°C | | Unit | |
|---------------------------------|-------------------------------|------------------------|---------------------|-----------|------|------|------------------|------|------|----|
| | | V _{CC} (V) | C _L (pF) | Min. | Typ. | Max. | Min. | Max. | | |
| Propagation delay time | t_{PLH} , t_{PHL} | — | 3.3±0.3 | 15 | — | 6.2 | 8.8 | 1.0 | 10.5 | ns |
| | | | | 50 | — | 9.6 | 13.5 | 1.0 | 14.5 | ns |
| | | | 5.0±0.5 | 15 | — | 4.3 | 5.9 | 1.0 | 7.0 | ns |
| | | | | 50 | — | 5.7 | 7.9 | 1.0 | 9.0 | ns |
| Input capacitance | C _{IN} | — | — | — | 4 | 10 | — | 10 | pF | |
| Equivalent internal capacitance | C _{PD} ^{*1} | — | — | — | 14 | — | — | — | pF | |

*1. C_{PD} is the no-load equivalent capacitance inside the circuitry. Refer to the measurement circuit shown below. Current consumption is averaged by the following equation.

$$I_{CC(opr)} = C_{PD} \times V_{CC} \times fin + I_{CC}$$

Measurement Circuit

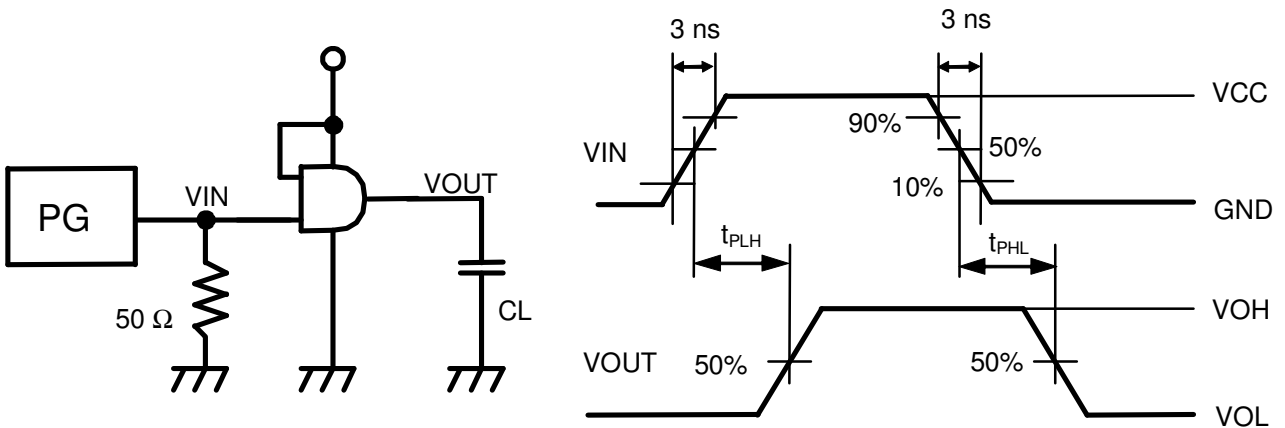

Remark No-load output during measurement of current consumption.

■ Input Pin Equivalent Circuit

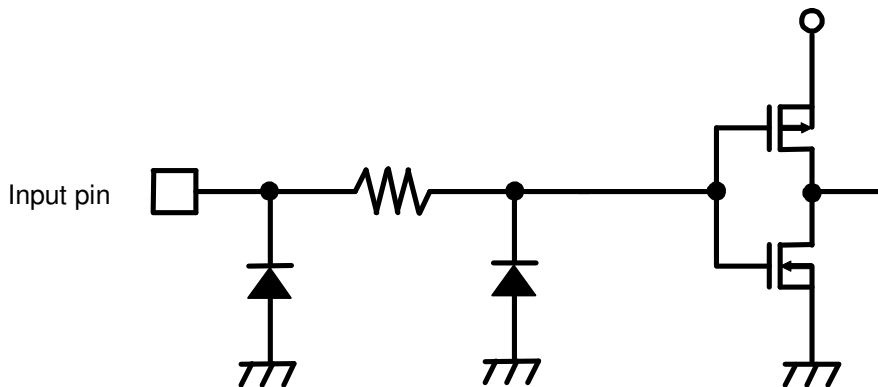

The S-75V14ANC is a SCHMITT INVERTER fabricated by utilizing advanced silicon-gate CMOS technology which provides the inherent benefit of CMOS low power consumption to achieve ultra high speed operation correspond to LSTTL IC's.

All gates of the internal circuitry have buffered outputs to ensure high noise immunity and output stability.

Input voltage is allowed to be applied even if power voltage is not supplied because no diode is inserted between an input pin and V_{CC} .

This allows for interfaces between power supplies of different voltage, output level conversion from 5 V to 3 V and battery backup applications.

■ Features

- Wide power supply range: 2 V to 5.5 V
- Low current consumption: 1.0 μ A max. (at 5.5 V, 25°C)
- Typical propagation delay: $t_{PD} = 5.5$ ns (at 5 V)
- High noise immunity: $V_{NIH} = V_{NIL} = 28\% V_{CC}$ min.
- Power down protection: All pins
- Lead-free

■ Applications

- Personal computers, peripherals
- Cellular phones
- Cameras
- Games

■ Package

- SC-88A

■ Pin Configuration

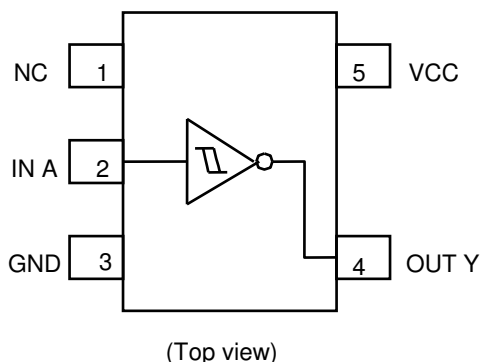

■ Marking Specification

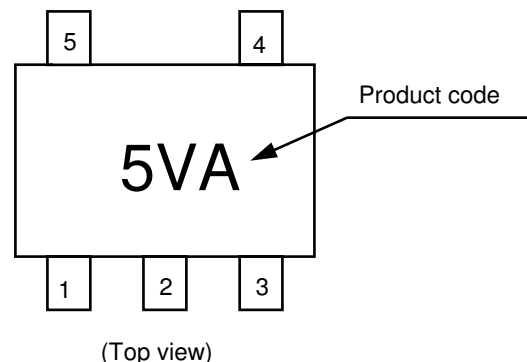

■ Logic Diagram

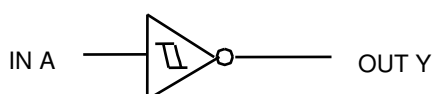

True values

| A | Y |
|---|---|
| L | H |
| H | L |

■ Product Name Structure

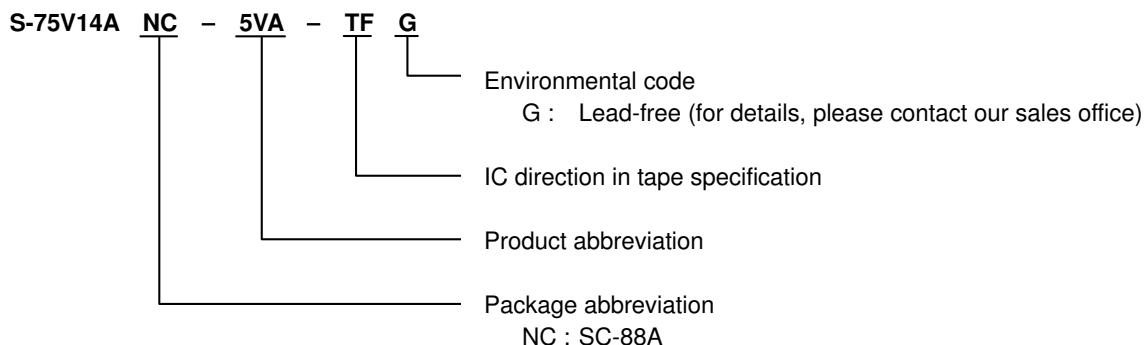

■ Absolute Maximum Ratings

(Ta = 25°C unless otherwise specified)

| Item | Symbol | Absolute Maximum Ratings | Unit |
|--------------------------------|-----------|---------------------------------|------|
| Power supply voltage | V_{CC} | -0.5 to +7.0 | V |
| Input voltage | V_{IN} | -0.5 to +7.0 | V |
| Output voltage | V_{OUT} | -0.5 to $V_{CC} + 0.5$ | V |
| Input parasitic diode current | I_{IK} | -20 | mA |
| Output parasitic diode current | I_{OK} | ±20 | mA |
| Output current | I_{OUT} | ±25 | mA |
| V_{CC} /GND current | I_{CC} | ±50 | mA |
| Power dissipation | P_D | 200 (When not mounted on board) | mW |
| | | 350*1 | mW |
| Operating ambient temperature | T_{opr} | -40 to +85 | °C |
| Storage temperature | T_{stg} | -65 to +150 | °C |
| Lead temperature (10 s) | T_L | 260 | °C |

*1. When mounted on board

[Mounted board]

(1) Board size : 114.3 mm × 76.2 mm × t1.6 mm

(2) Board name : JEDEC STANDARD51-7

Caution The absolute maximum ratings are rated values exceeding which the product could suffer physical damage. These values must therefore not be exceeded under any conditions.

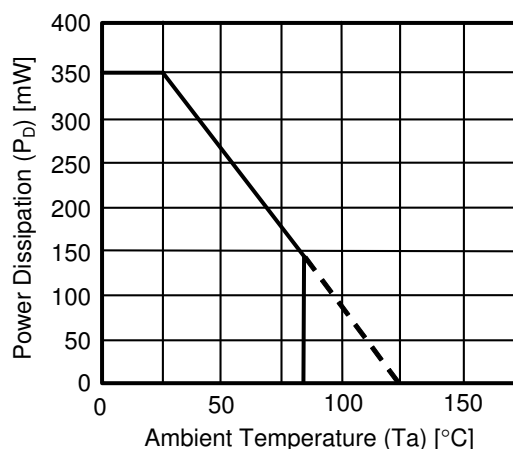

Power Dissipation of Package (When Mounted on Board)

■ Recommended Operating Conditions

| Item | Symbol | Standard | Unit |
|----------------|-----------|---------------|------|
| Power voltage | V_{CC} | 2 to 5.5 | V |
| Input voltage | V_{IN} | 0 to 5.5 | V |
| Output voltage | V_{OUT} | 0 to V_{CC} | V |

■ DC Electrical Characteristics

| Item | Symbol | Conditions | Ta = 25°C | | | Ta = -40 to 85°C | | Unit | | | |
|---------------------|-----------|----------------------------------|-------------------|--------------------------|------|------------------|------|-----------|---------|------|---|
| | | | V_{CC} | Min. | Typ. | Max. | Min. | | Max. | | |
| Threshold voltage | “H” level | V_P | — | 3.0 | — | — | 2.20 | — | 2.20 | V | |
| | | | | 4.5 | — | — | 3.15 | — | 3.15 | V | |
| | | | | 5.5 | — | — | 3.85 | — | 3.85 | V | |
| | “L” level | V_N | — | 3.0 | 0.90 | — | — | 0.90 | — | V | |
| | | | | 4.5 | 1.35 | — | — | 1.35 | — | V | |
| | | | | 5.5 | 1.65 | — | — | 1.65 | — | V | |
| Hysteresis voltage | V_H | — | 3.0 | 0.30 | — | 1.20 | 0.30 | 1.20 | V | | |
| | | | 4.5 | 0.40 | — | 1.40 | 0.40 | 1.40 | V | | |
| | | | 5.5 | 0.5 | — | 1.60 | 0.5 | 1.60 | V | | |
| Output voltage | “H” level | V_{OH} | $V_{IN} = V_{IL}$ | $I_{OH} = -50 \mu A$ | 2.0 | 1.9 | 2.0 | — | 1.9 | — | V |
| | | | | | 3.0 | 2.9 | 3.0 | — | 2.9 | — | V |
| | | | | | 4.5 | 4.4 | 4.5 | — | 4.4 | — | V |
| | | | | $I_{OH} = -4 \text{ mA}$ | 3.0 | 2.58 | — | — | 2.48 | — | V |
| | | | | | 4.5 | 3.94 | — | — | 3.80 | — | V |
| | | | | | 5.5 | — | — | — | — | — | V |
| | “L” level | V_{OL} | $V_{IN} = V_{IH}$ | $I_{OL} = 50 \mu A$ | 2.0 | — | 0 | 0.1 | — | 0.1 | V |
| | | | | | 3.0 | — | 0 | 0.1 | — | 0.1 | V |
| | | | | | 4.5 | — | 0 | 0.1 | — | 0.1 | V |
| | | | | $I_{OL} = 4 \text{ mA}$ | 3.0 | — | — | 0.36 | — | 0.44 | V |
| | | | | | 4.5 | — | — | 0.36 | — | 0.44 | V |
| | | | | | 5.5 | — | — | — | — | — | V |
| Input current | I_{IN} | $V_{IN} = 5.5 \text{ V or GND}$ | 0 to 5.5 | — | — | ± 0.1 | — | ± 1.0 | μA | | |
| Current consumption | I_{CC} | $V_{IN} = V_{CC} \text{ or GND}$ | 5.5 | — | — | 1.0 | — | 10.0 | μA | | |

■ AC Electrical Characteristics

(Input $t_R = t_F = 3$ ns unless otherwise specified)

| Item | Symbol | Measurement Conditions | | Ta = 25°C | | | Ta = -40 to 85°C | | Unit | |
|---------------------------------|-------------------------------|------------------------|---------------------|-----------|------|------|------------------|------|------|----|
| | | V _{CC} (V) | C _L (pF) | Min. | Typ. | Max. | Min. | Max. | | |
| Propagation delay time | t_{PLH} , t_{PHL} | — | 3.3±0.3 | 15 | — | 8.3 | 12.8 | 1.0 | 15.0 | ns |
| | | | | 50 | — | 10.8 | 16.3 | 1.0 | 18.5 | ns |
| | | | 5.0±0.5 | 15 | — | 5.5 | 8.6 | 1.0 | 10.0 | ns |
| | | | | 50 | — | 7.0 | 10.6 | 1.0 | 12.0 | ns |
| Input capacitance | C _{IN} | — | — | — | 4 | 10 | — | 10 | pF | |
| Equivalent internal capacitance | C _{PD} ^{*1} | — | — | — | 14 | — | — | — | pF | |

*1. C_{PD} is the no-load equivalent capacitance inside the circuitry. Refer to the measurement circuit shown below. Current consumption is averaged by the following equation.

$$I_{CC(opr)} = C_{PD} \times V_{CC} \times fin + I_{CC}$$

Measurement Circuit

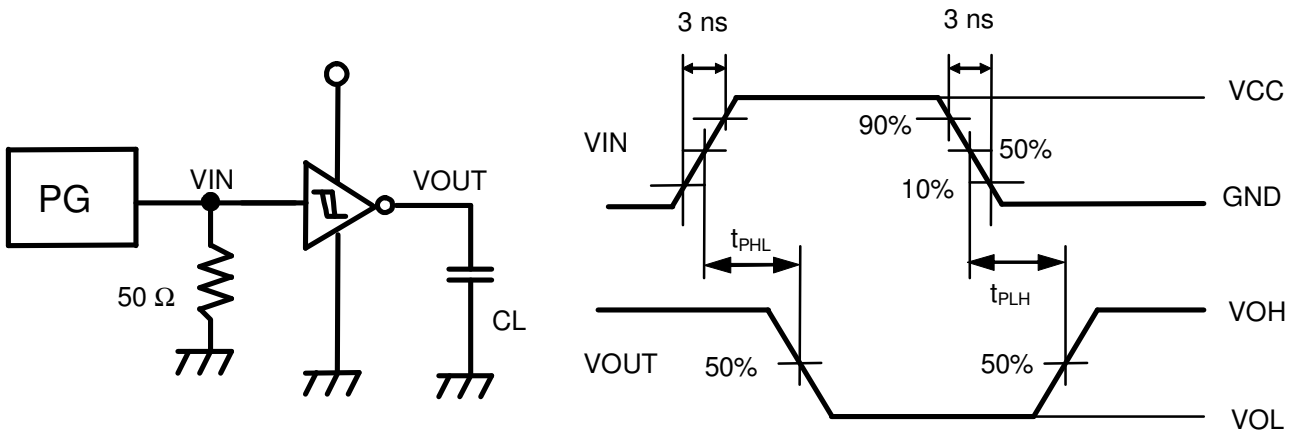

Remark No-load output during measurement of current consumption.

■ Input Pin Equivalent Circuit

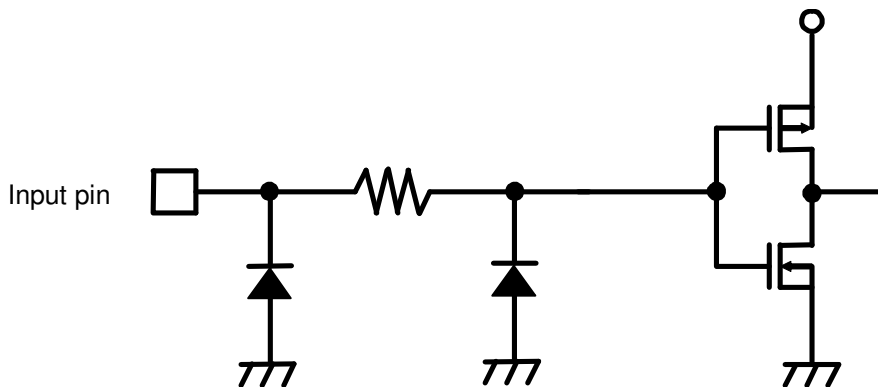

The S-75V32ANC is a single 2-input OR gate fabricated by utilizing advanced silicon-gate CMOS technology which provides the inherent benefit of CMOS low power consumption to achieve ultra high speed operation correspond to LSTTL IC's.

All gates of the internal circuitry have buffered outputs to ensure high noise immunity and output stability.

Input voltage is allowed to be applied even if power voltage is not supplied because no diode is inserted between an input pin and V_{CC} .

This allows for interfaces between power supplies of different voltage, output level conversion from 5 V to 3 V and battery backup applications.

■ Features

- Wide power supply range: 2 V to 5.5 V
- Low current consumption: 1.0 μ A max. (at 5.5 V, 25°C)
- Typical propagation delay: $t_{PD} = 3.8$ ns (at 5 V)
- High noise immunity: $V_{NIH} = V_{NIL} = 28\% V_{CC}$ min.
- Power down protection: All pins
- Lead-free

■ Applications

- Personal computers, peripherals
- Cellular phones
- Cameras
- Games

■ Package

- SC-88A

■ Pin Configuration

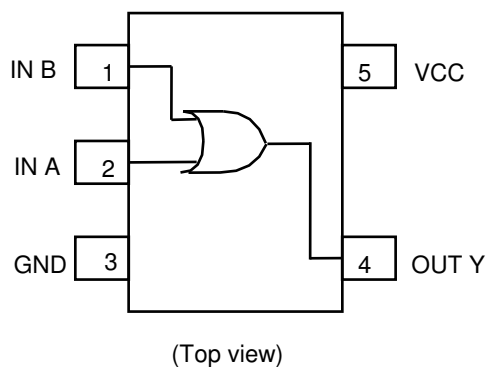

■ Marking Specification

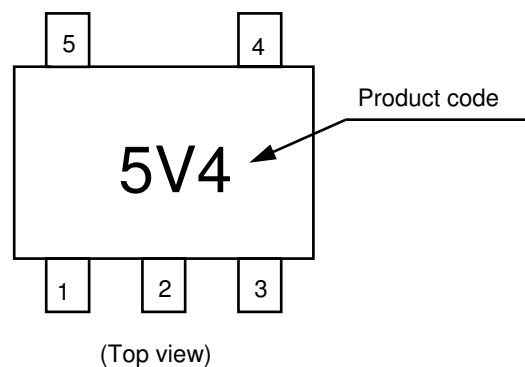

■ Logic Diagram

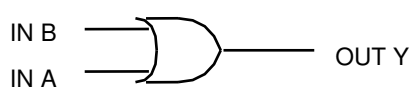

True values

| A | B | Y |
|---|---|---|
| L | L | L |
| L | H | H |
| H | L | H |
| H | H | H |

■ Product Name Structure

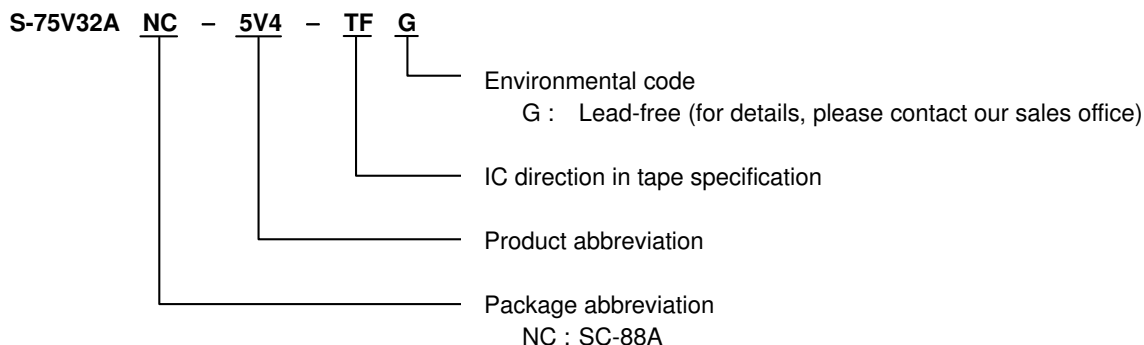

■ Absolute Maximum Ratings

(Ta = 25°C unless otherwise specified)

| Item | Symbol | Absolute Maximum Ratings | Unit |
|--------------------------------|-----------|---------------------------------|------|
| Power supply voltage | V_{CC} | -0.5 to +7.0 | V |
| Input voltage | V_{IN} | -0.5 to +7.0 | V |
| Output voltage | V_{OUT} | -0.5 to $V_{CC} + 0.5$ | V |
| Input parasitic diode current | I_{IK} | -20 | mA |
| Output parasitic diode current | I_{OK} | ±20 | mA |
| Output current | I_{OUT} | ±25 | mA |
| V_{CC}/GND current | I_{CC} | ±50 | mA |
| Power dissipation | P_D | 200 (When not mounted on board) | mW |
| | | 350*1 | mW |
| Operating ambient temperature | T_{opr} | -40 to +85 | °C |
| Storage temperature | T_{stg} | -65 to +150 | °C |
| Lead temperature (10 s) | T_L | 260 | °C |

*1. When mounted on board
[Mounted board]

- (1) Board size : 114.3 mm × 76.2 mm × t1.6 mm
- (2) Board name : JEDEC STANDARD51-7

Caution The absolute maximum ratings are rated values exceeding which the product could suffer physical damage. These values must therefore not be exceeded under any conditions.

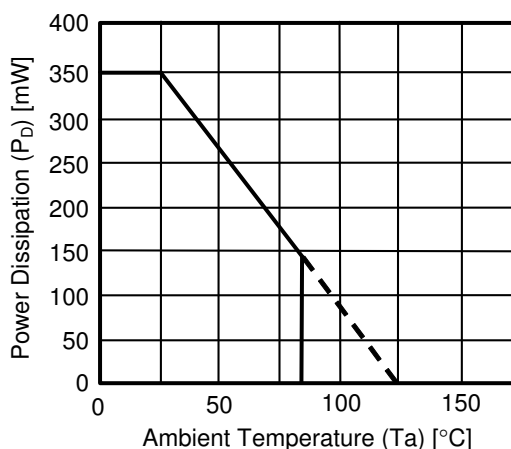

Power Dissipation of Package (When Mounted on Board)

■ Recommended Operating Conditions

| Item | Symbol | Standard | Unit |
|------------------------|------------|--------------------------------------|------|
| Power voltage | V_{CC} | 2 to 5.5 | V |
| Input voltage | V_{IN} | 0 to 5.5 | V |
| Output voltage | V_{OUT} | 0 to V_{CC} | V |
| Input rise / fall time | t_R, t_F | 0 to 100 ($V_{CC} = 3.3 \pm 0.3$ V) | ns |
| | | 0 to 20 ($V_{CC} = 5 \pm 0.5$ V) | ns |

■ DC Electrical Characteristics

| Item | Symbol | Conditions | $T_a = 25^\circ\text{C}$ | | | $T_a = -40$ to 85°C | | Unit | | | |
|---------------------|-----------|---------------------------------|----------------------------------|----------------------------|---------------------|-----------------------------------|---------------------|---------------------|---------------------|------|---|
| | | | V_{CC} | Min. | Typ. | Max. | Min. | | Max. | | |
| Input voltage | "H" level | V_{IH} | — | 2.0 | 1.5 | — | — | 1.5 | — | V | |
| | | | | 3 to 5.5 | $V_{CC} \times 0.7$ | — | — | $V_{CC} \times 0.7$ | — | V | |
| | "L" level | V_{IL} | — | 2.0 | — | — | 0.5 | — | 0.5 | V | |
| | | | | 3 to 5.5 | — | — | $V_{CC} \times 0.3$ | — | $V_{CC} \times 0.3$ | V | |
| Output voltage | "H" level | V_{OH} | $V_{IN} = V_{IL}$ or V_{IH} | $I_{OH} = -50 \mu\text{A}$ | 2.0 | 1.9 | 2.0 | — | 1.9 | — | V |
| | | | | | 3.0 | 2.9 | 3.0 | — | 2.9 | — | V |
| | | | | | 4.5 | 4.4 | 4.5 | — | 4.4 | — | V |
| | | | | $I_{OH} = -4 \text{ mA}$ | 3.0 | 2.58 | — | — | 2.48 | — | V |
| | | | | | 4.5 | 3.94 | — | — | 3.80 | — | V |
| | | | | | | | | | | | |
| | "L" level | V_{OL} | $V_{IN} = V_{IL}$ | $I_{OL} = 50 \mu\text{A}$ | 2.0 | — | 0 | 0.1 | — | 0.1 | V |
| | | | | | 3.0 | — | 0 | 0.1 | — | 0.1 | V |
| | | | | | 4.5 | — | 0 | 0.1 | — | 0.1 | V |
| | | | | | 3.0 | — | — | 0.36 | — | 0.44 | V |
| | | | | | | | | | | | |
| 4.5 | | | | | — | — | 0.36 | — | 0.44 | V | |
| | | | | | | | | | | | |
| Input current | I_{IN} | $V_{IN} = 5.5 \text{ V}$ or GND | 0 to 5.5 | — | — | ± 0.1 | — | ± 1.0 | μA | | |
| Current consumption | I_{CC} | $V_{IN} = V_{CC}$ or GND | 5.5 | — | — | 1.0 | — | 10.0 | μA | | |

■ AC Electrical Characteristics

(Input $t_R = t_F = 3$ ns unless otherwise specified)

| Item | Symbol | Measurement Conditions | | Ta = 25°C | | | Ta = -40 to 85°C | | Unit |
|---------------------------------|-------------------------------|------------------------|---------------------|-----------|------|------|------------------|------|------|
| | | V _{CC} (V) | C _L (pF) | Min. | Typ. | Max. | Min. | Max. | |
| Propagation delay time | t_{PLH} , t_{PHL} | 3.3±0.3 | 15 | — | 5.5 | 7.9 | 1.0 | 9.5 | ns |
| | | | 50 | — | 10.0 | 14.0 | 1.0 | 15.0 | ns |
| | | 5.0±0.5 | 15 | — | 3.8 | 5.5 | 1.0 | 6.5 | ns |
| | | | 50 | — | 6.1 | 8.5 | 1.0 | 9.0 | ns |
| Input capacitance | C _{IN} | — | — | 4 | 10 | — | 10 | pF | |
| Equivalent internal capacitance | C _{PD} ^{*1} | — | — | 15 | — | — | — | pF | |

*1. C_{PD} is the no-load equivalent capacitance inside the circuitry. Refer to the measurement circuit shown below. Current consumption is averaged by the following equation.

$$I_{CC(opr)} = C_{PD} \times V_{CC} \times fin + I_{CC}$$

Measurement Circuit

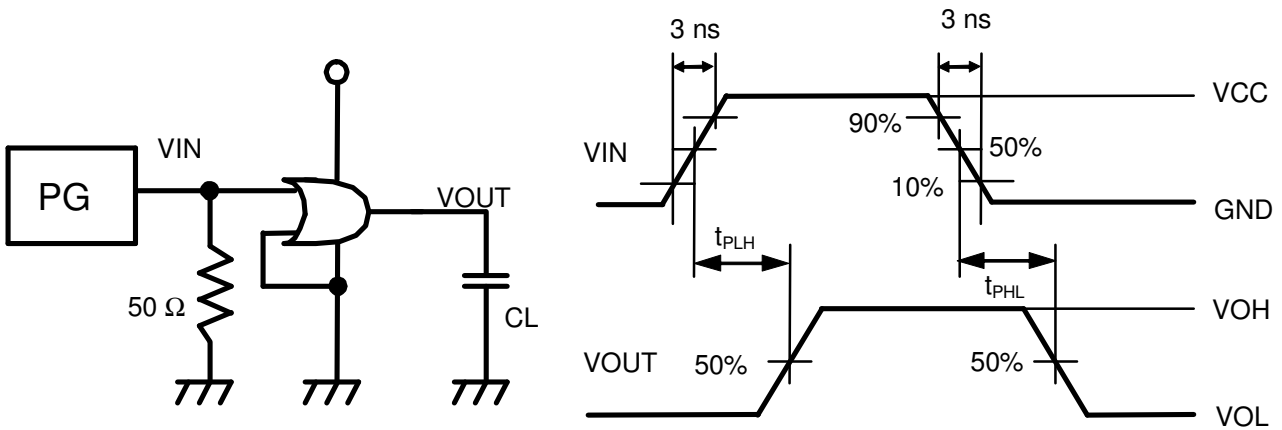

Remark No-load output during measurement of current consumption.

■ Input Pin Equivalent Circuit

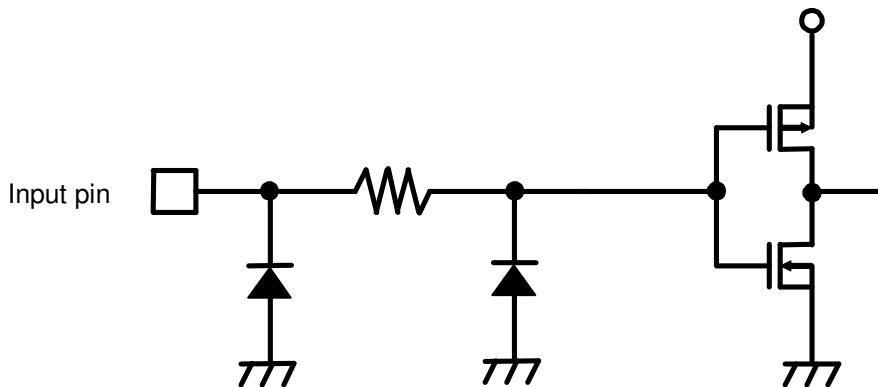

The S-75V86ANC is a EXCLUSIVE OR GATE fabricated by utilizing advanced silicon-gate CMOS technology which provides the inherent benefit of CMOS low power consumption to achieve ultra high speed operation correspond to LSTTL IC's.

All gates of the internal circuitry have buffered outputs to ensure high noise immunity and output stability.

Input voltage is allowed to be applied even if power voltage is not supplied because no diode is inserted between an input pin and V_{CC} .

This allows for interfaces between power supplies of different voltage, output level conversion from 5 V to 3 V and battery backup applications.

■ Features

- Wide power supply range: 2 V to 5.5 V
- Low current consumption: 1.0 μ A max. (at 5.5 V, 25°C)
- Typical propagation delay: $t_{PD} = 4.8$ ns (at 5 V)
- High noise immunity: $V_{NIH} = V_{NIL} = 28\% V_{CC}$ min.
- Power down protection: All pins
- Lead-free

■ Applications

- Personal computers, peripherals
- Cellular phones
- Cameras
- Games

■ Package

- SC-88A

■ Pin Configuration

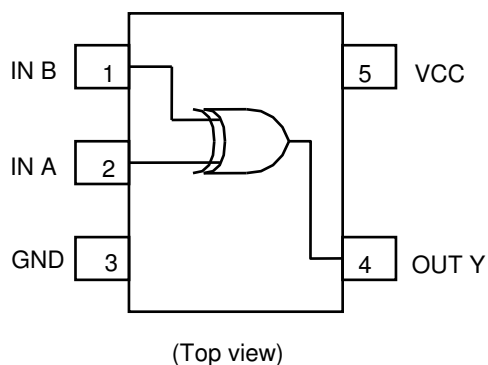

■ Marking Specification

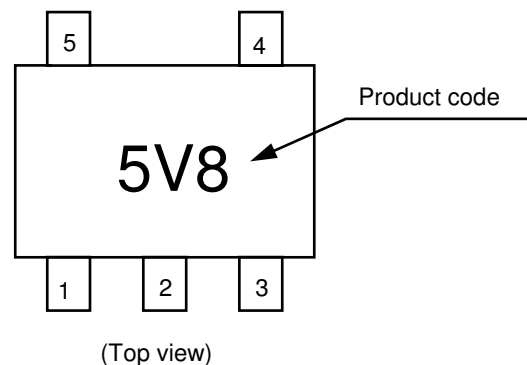

■ Logic Diagram

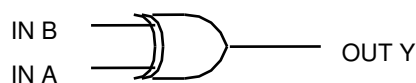

True values

| A | B | Y |
|---|---|---|
| L | L | L |
| L | H | H |
| H | L | H |
| H | H | L |

■ Product Name Structure

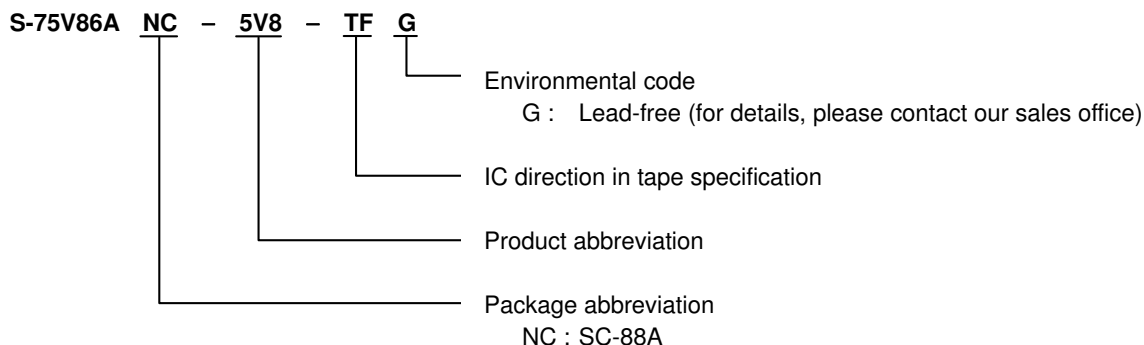

■ Absolute Maximum Ratings

(Ta = 25°C unless otherwise specified)

| Item | Symbol | Absolute Maximum Ratings | Unit |
|--------------------------------|-----------|---------------------------------|------|
| Power supply voltage | V_{CC} | -0.5 to +7.0 | V |
| Input voltage | V_{IN} | -0.5 to +7.0 | V |
| Output voltage | V_{OUT} | -0.5 to $V_{CC} + 0.5$ | V |
| Input parasitic diode current | I_{IK} | -20 | mA |
| Output parasitic diode current | I_{OK} | ±20 | mA |
| Output current | I_{OUT} | ±25 | mA |
| V_{CC} /GND current | I_{CC} | ±50 | mA |
| Power dissipation | P_D | 200 (When not mounted on board) | mW |
| | | 350*1 | mW |
| Operating ambient temperature | T_{opr} | -40 to +85 | °C |
| Storage temperature | T_{stg} | -65 to +150 | °C |
| Lead temperature (10 s) | T_L | 260 | °C |

*1. When mounted on board
[Mounted board]

- (1) Board size : 114.3 mm × 76.2 mm × t1.6 mm
- (2) Board name : JEDEC STANDARD51-7

Caution The absolute maximum ratings are rated values exceeding which the product could suffer physical damage. These values must therefore not be exceeded under any conditions.

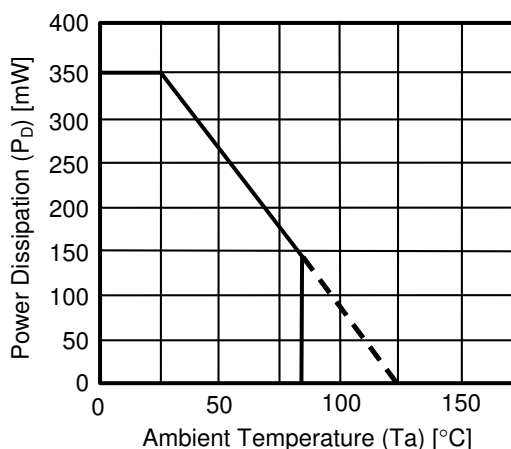

Power Dissipation of Package (When Mounted on Board)

■ Recommended Operating Conditions

| Item | Symbol | Standard | Unit |
|------------------------|------------|--------------------------------------|------|
| Power voltage | V_{CC} | 2 to 5.5 | V |
| Input voltage | V_{IN} | 0 to 5.5 | V |
| Output voltage | V_{OUT} | 0 to V_{CC} | V |
| Input rise / fall time | t_R, t_F | 0 to 100 ($V_{CC} = 3.3 \pm 0.3$ V) | ns |
| | | 0 to 20 ($V_{CC} = 5 \pm 0.5$ V) | ns |

■ DC Electrical Characteristics

| Item | Symbol | Conditions | $T_a = 25^\circ\text{C}$ | | | $T_a = -40$ to 85°C | | Unit | | | |
|---------------------|-----------|---------------------------------|----------------------------------|----------------------------|---------------------|-----------------------------------|---------------------|---------------------|---------------------|------|---|
| | | | V_{CC} | Min. | Typ. | Max. | Min. | | Max. | | |
| Input voltage | "H" level | V_{IH} | — | 2.0 | 1.5 | — | — | 1.5 | — | V | |
| | | | | 3 to 5.5 | $V_{CC} \times 0.7$ | — | — | $V_{CC} \times 0.7$ | — | V | |
| | "L" level | V_{IL} | — | 2.0 | — | — | 0.5 | — | 0.5 | V | |
| | | | | 3 to 5.5 | — | — | $V_{CC} \times 0.3$ | — | $V_{CC} \times 0.3$ | V | |
| Output voltage | "H" level | V_{OH} | $V_{IN} = V_{IL}$ or V_{IH} | $I_{OH} = -50 \mu\text{A}$ | 2.0 | 1.9 | 2.0 | — | 1.9 | — | V |
| | | | | | 3.0 | 2.9 | 3.0 | — | 2.9 | — | V |
| | | | | | 4.5 | 4.4 | 4.5 | — | 4.4 | — | V |
| | | | | $I_{OH} = -4 \text{ mA}$ | 3.0 | 2.58 | — | — | 2.48 | — | V |
| | | | | | 4.5 | 3.94 | — | — | 3.80 | — | V |
| | | | | | | | | | | | |
| | "L" level | V_{OL} | $V_{IN} = V_{IL}$ or V_{IH} | $I_{OL} = 50 \mu\text{A}$ | 2.0 | — | 0 | 0.1 | — | 0.1 | V |
| | | | | | 3.0 | — | 0 | 0.1 | — | 0.1 | V |
| | | | | | 4.5 | — | 0 | 0.1 | — | 0.1 | V |
| | | | | | 3.0 | — | — | 0.36 | — | 0.44 | V |
| | | | | | | | | | | | |
| 4.5 | — | — | 0.36 | — | 0.44 | V | | | | | |
| | | | | | | | | | | | |
| Input current | I_{IN} | $V_{IN} = 5.5 \text{ V}$ or GND | 0 to 5.5 | — | — | ± 0.1 | — | ± 1.0 | μA | | |
| Current consumption | I_{CC} | $V_{IN} = V_{CC}$ or GND | 5.5 | — | — | 1.0 | — | 10.0 | μA | | |

■ AC Electrical Characteristics

(Input $t_R = t_F = 3$ ns unless otherwise specified)

| Item | Symbol | Measurement Conditions | | Ta = 25°C | | | Ta = -40 to 85°C | | Unit |
|---------------------------------|-------------------------------|------------------------|---------------------|-----------|------|------|------------------|------|------|
| | | V _{CC} (V) | C _L (pF) | Min. | Typ. | Max. | Min. | Max. | |
| Propagation delay time | t_{PLH} , t_{PHL} | 3.3±0.3 | 15 | — | 7.0 | 11.0 | 1.0 | 13.0 | ns |
| | | | 50 | — | 10.4 | 14.5 | 1.0 | 16.5 | ns |
| | | 5.0±0.5 | 15 | — | 4.8 | 6.8 | 1.0 | 8.0 | ns |
| | | | 50 | — | 6.5 | 9.0 | 1.0 | 10.0 | ns |
| Input capacitance | C _{IN} | — | — | 4 | 10 | — | 10 | pF | |
| Equivalent internal capacitance | C _{PD} ^{*1} | — | — | 18 | — | — | — | pF | |

*1. C_{PD} is the no-load equivalent capacitance inside the circuitry. Refer to the measurement circuit shown below. Current consumption is averaged by the following equation.

$$I_{CC(opr)} = C_{PD} \times V_{CC} \times fin + I_{CC}$$

Measurement Circuit

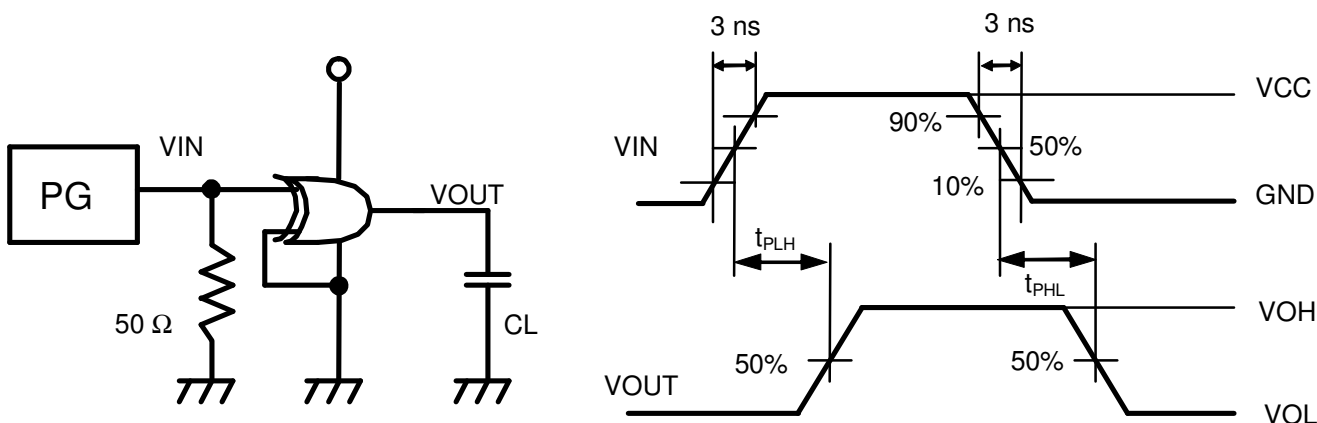

Remark No-load output during measurement of current consumption.

■ Input Pin Equivalent Circuit

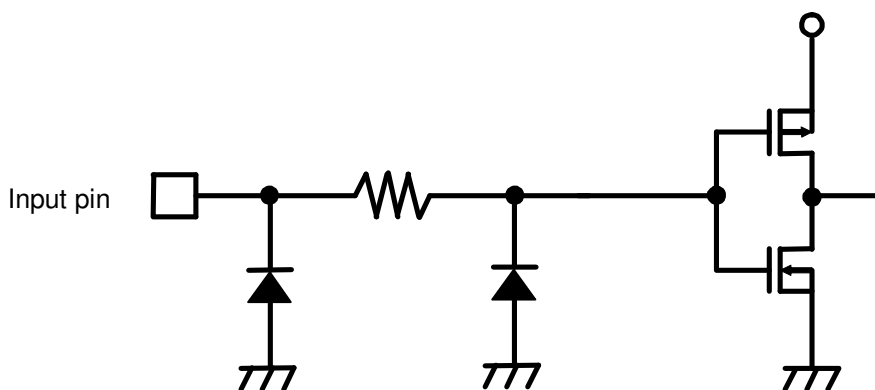

The S-75L00ANC is a single 2-input NAND gate fabricated by utilizing advanced silicon-gate CMOS technology which provides the inherent benefit of CMOS low power consumption to achieve operation by only a couple of batteries (1 to 3 V). The internal circuitry has buffered outputs to ensure high noise immunity and output stability.

Input voltage is allowed to be applied even if power voltage is not supplied because no diode is inserted between an input pin and V_{CC} .

This allows for interfaces between power supplies of different voltage, output level conversion from 3 V to 1 V and battery backup applications.

■ Features

- Wide power supply range: 1 V to 3.6 V
- Low current consumption: 1.0 μ A max. (at 3.6 V, 25°C)
- Typical propagation delay: $t_{PD} = 7$ ns (at 3 V)
- High noise immunity: $V_{NIH} = V_{NIL} = 28\% V_{CC}$ min.
- Power down protection: All pins
- Lead-free

■ Applications

- Personal computers, peripherals
- Cellular phones
- Cameras
- Games

■ Package

- SC-88A

■ Pin Configuration

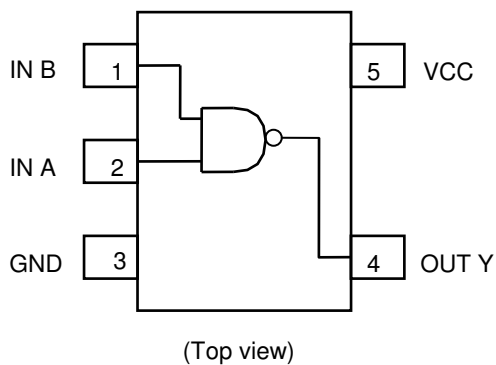

■ Marking Specification

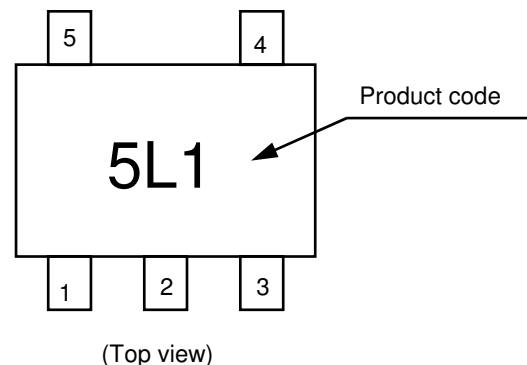

■ Logic Diagram

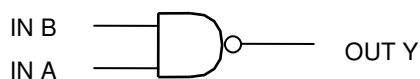

True values

| A | B | Y |
|---|---|---|
| L | L | H |
| L | H | H |
| H | L | H |
| H | H | L |

■ Product Name Structure

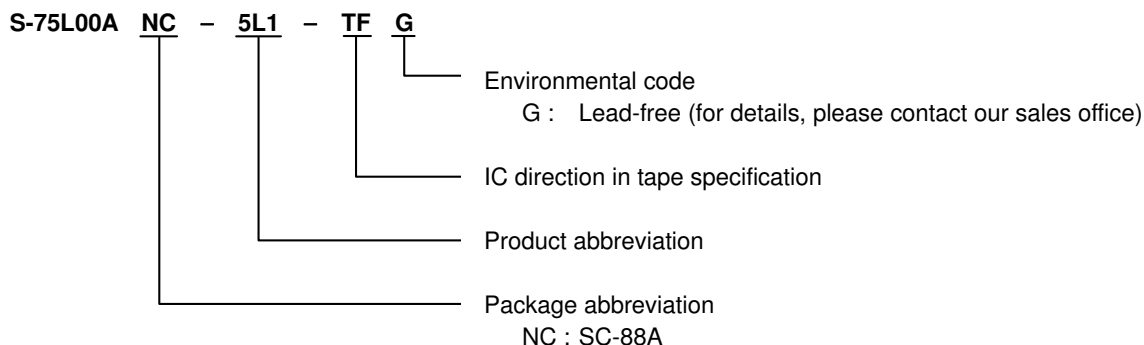

■ Absolute Maximum Ratings

(Ta = 25°C unless otherwise specified)

| Item | Symbol | Absolute Maximum Ratings | Unit |
|--------------------------------|-----------|---------------------------------|------|
| Power supply voltage | V_{CC} | -0.5 to +5.0 | V |
| Input voltage | V_{IN} | -0.5 to +5.0 | V |
| Output voltage | V_{OUT} | -0.5 to $V_{CC} + 0.5$ | V |
| Input parasitic diode current | I_{IK} | -20 | mA |
| Output parasitic diode current | I_{OK} | ±20 | mA |
| Output current | I_{OUT} | ±12.5 | mA |
| V_{CC}/GND current | I_{CC} | ±25 | mA |
| Power dissipation | P_D | 200 (When not mounted on board) | mW |
| | | 350*1 | mW |
| Operating ambient temperature | T_{opr} | -40 to +85 | °C |
| Storage temperature | T_{stg} | -65 to +150 | °C |
| Lead temperature (10 s) | T_L | 260 | °C |

*1. When mounted on board
[Mounted board]

- (1) Board size : 114.3 mm × 76.2 mm × t1.6 mm
- (2) Board name : JEDEC STANDARD51-7

Caution The absolute maximum ratings are rated values exceeding which the product could suffer physical damage. These values must therefore not be exceeded under any conditions.

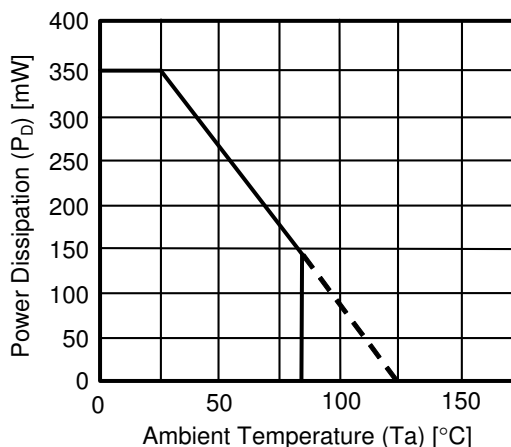

Power Dissipation of Package (When Mounted on Board)

■ Recommended Operating Conditions

| Item | Symbol | Standard | Unit |
|------------------------|------------|-------------------------------|------|
| Power voltage | V_{CC} | 1 to 3.6 | V |
| Input voltage | V_{IN} | 0 to 3.6 | V |
| Output voltage | V_{OUT} | 0 to V_{CC} | V |
| Input rise / fall time | t_R, t_F | 0 to 1000 ($V_{CC} = 1.0$ V) | ns |
| | | 0 to 500 ($V_{CC} = 2.0$ V) | ns |
| | | 0 to 400 ($V_{CC} = 3.0$ V) | ns |

■ DC Electrical Characteristics

| Item | Symbol | Conditions | $T_a = 25^\circ\text{C}$ | | | $T_a = -40$ to 85°C | | Unit | | | |
|---------------------|-----------|--------------------------|----------------------------------|----------------------------|------|-----------------------------------|------|-----------|---------------|------|---|
| | | | V_{CC} | Min. | Typ. | Max. | Min. | | Max. | | |
| Input voltage | "H" level | V_{IH} | — | 1.0 | 0.75 | — | — | 0.75 | — | V | |
| | | | | 1.5 | 1.05 | — | — | 1.05 | — | V | |
| | | | | 3.0 | 2.10 | — | — | 2.10 | — | V | |
| | "L" level | V_{IL} | — | 1.0 | — | — | 0.25 | — | 0.25 | V | |
| | | | | 1.5 | — | — | 0.45 | — | 0.45 | V | |
| | | | | 3.0 | — | — | 0.90 | — | 0.90 | V | |
| Output voltage | "H" level | V_{OH} | $V_{IN} = V_{IH}$ or V_{IL} | $I_{OH} = -20 \mu\text{A}$ | 1.0 | 0.9 | 1.0 | — | 0.9 | — | V |
| | | | | | 1.5 | 1.4 | 1.5 | — | 1.4 | — | V |
| | | | | | 3.0 | 2.9 | 3.0 | — | 2.9 | — | V |
| | | | | $I_{OH} = -1 \text{ mA}$ | 1.5 | 1.07 | 1.23 | — | 0.99 | — | V |
| | | | | | 3.0 | 2.61 | 2.68 | — | 2.55 | — | V |
| | | | | | | | | | | | |
| | "L" level | V_{OL} | $V_{IN} = V_{IH}$ | $I_{OL} = 20 \mu\text{A}$ | 1.0 | — | 0 | 0.1 | — | 0.1 | V |
| | | | | | 1.5 | — | 0 | 0.1 | — | 0.1 | V |
| | | | | | 3.0 | — | 0 | 0.1 | — | 0.1 | V |
| | | | | $I_{OL} = 1 \text{ mA}$ | 1.5 | — | 0.23 | 0.31 | — | 0.37 | V |
| | | | | | 3.0 | — | 0.23 | 0.31 | — | 0.33 | V |
| | | | | | | | | | | | |
| Input current | I_{IN} | $V_{IN} = V_{CC}$ or GND | 3.6 | — | — | ± 0.1 | — | ± 1.0 | μA | | |
| Current consumption | I_{CC} | $V_{IN} = V_{CC}$ or GND | 3.6 | — | — | 1.0 | — | 10.0 | μA | | |

■ AC Electrical Characteristics

($C_L = 15$ pf, Input $t_R = t_F = 6$ ns, $V_{CC} = 3.3 \pm 0.3$ V, $T_a = 25^\circ\text{C}$ unless otherwise specified)

| Item | Symbol | Measurement Conditions | Min. | Typ. | Max. | Unit |
|-------------------------|--------------------------|------------------------|------|------|------|------|
| Output rise / fall time | t_{TLH} , t_{THL} | — | — | 4.0 | 8.5 | ns |
| Propagation delay time | t_{PLH} , t_{PHL} | — | — | 6.0 | 9.0 | ns |

($C_L = 25$ pf, Input $t_R = t_F = 6$ ns unless otherwise specified)

| Item | Symbol | Measurement Conditions | $T_a = 25^\circ\text{C}$ | | | $T_a = -40$ to 85°C | | Unit | |
|---------------------------------|--------------------------|------------------------|--------------------------|------|------|-----------------------------------|------|------|------|
| | | | V_{CC} (V) | Min. | Typ. | Max. | Min. | | Max. |
| Output rise / fall time | t_{TLH} , t_{THL} | — | 1.0 | — | 35 | 70 | — | 90 | ns |
| | | | 1.5 | — | 15 | 25 | — | 30 | ns |
| | | | 3.0 | — | 7 | 10 | — | 14 | ns |
| Propagation delay time | t_{PLH} , t_{PHL} | — | 1.0 | — | 30 | 60 | — | 75 | ns |
| | | | 1.5 | — | 15 | 25 | — | 30 | ns |
| | | | 3.0 | — | 7 | 10 | — | 14 | ns |
| Input capacitance | C_{IN} | — | — | 5 | 10 | — | 10 | pF | |
| Equivalent internal capacitance | C_{PD}^{*1} | — | — | 10 | — | — | — | pF | |

*1. C_{PD} is the no-load equivalent capacitance inside the circuitry. Refer to the measurement circuit shown below.
 Current consumption is averaged by the following equation.

$$I_{CC(opr)} = C_{PD} \times V_{CC} \times fin + I_{CC}$$

Measurement Circuit

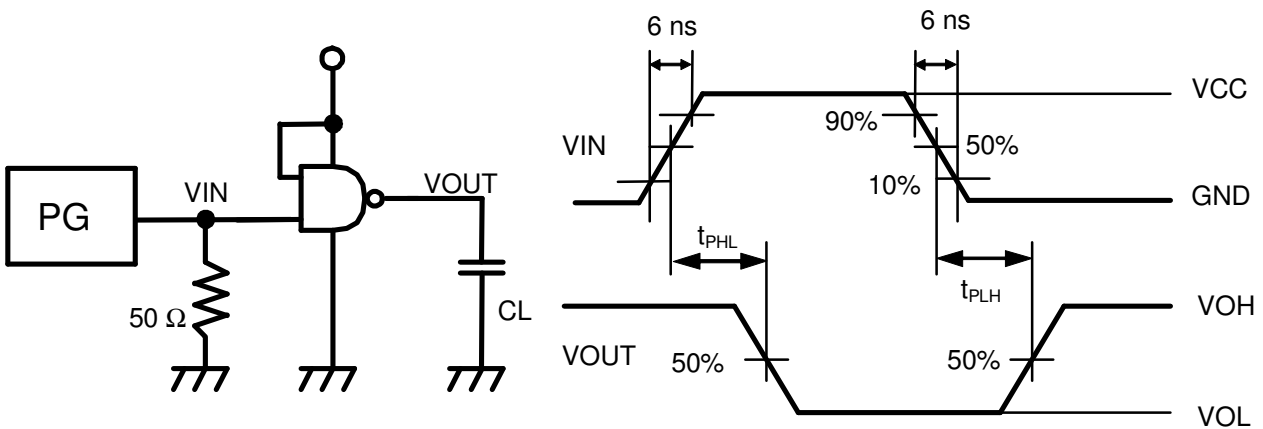

Remark No-load output during measurement of current consumption.

■ Input Pin Equivalent Circuit

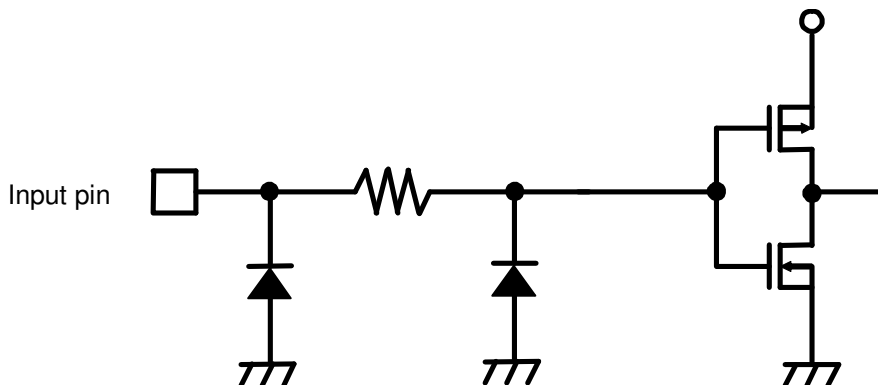

The S-75L02ANC is a single 2-input NOR gate fabricated by utilizing advanced silicon-gate CMOS technology which provides the inherent benefit of CMOS low power consumption to achieve operation by only a couple of batteries (1 to 3 V). The internal circuitry has buffered outputs to ensure high noise immunity and output stability.

Input voltage is allowed to be applied even if power voltage is not supplied because no diode is inserted between an input pin and V_{CC} .

This allows for interfaces between power supplies of different voltage, output level conversion from 3 V to 1 V and battery backup applications.

■ Features

- Wide power supply range: 1 V to 3.6 V
- Low current consumption: 1.0 μ A max. (at 3.6 V, 25°C)
- Typical propagation delay: $t_{PD} = 7$ ns (at 3 V)
- High noise immunity: $V_{NIH} = V_{NIL} = 28\% V_{CC}$ min.
- Power down protection: All pins
- Lead-free

■ Applications

- Personal computers, peripherals
- Cellular phones
- Cameras
- Games

■ Package

- SC-88A

■ Pin Configuration

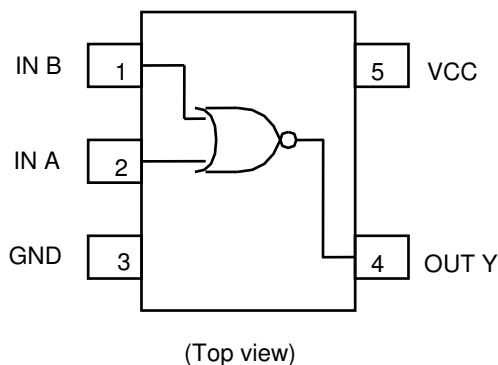

■ Marking Specification

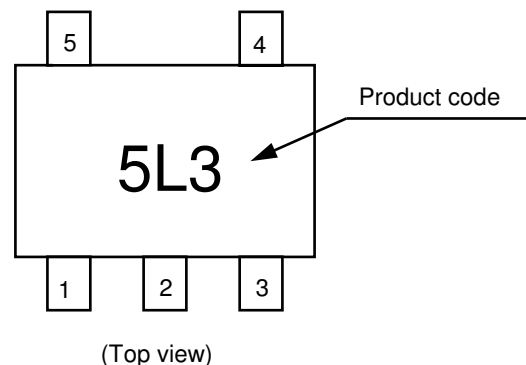

■ Logic Diagram

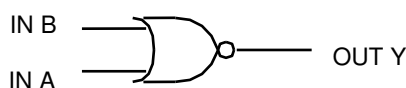

True values

| A | B | Y |
|---|---|---|
| L | L | H |
| L | H | L |
| H | L | L |
| H | H | L |

■ Product Name Structure

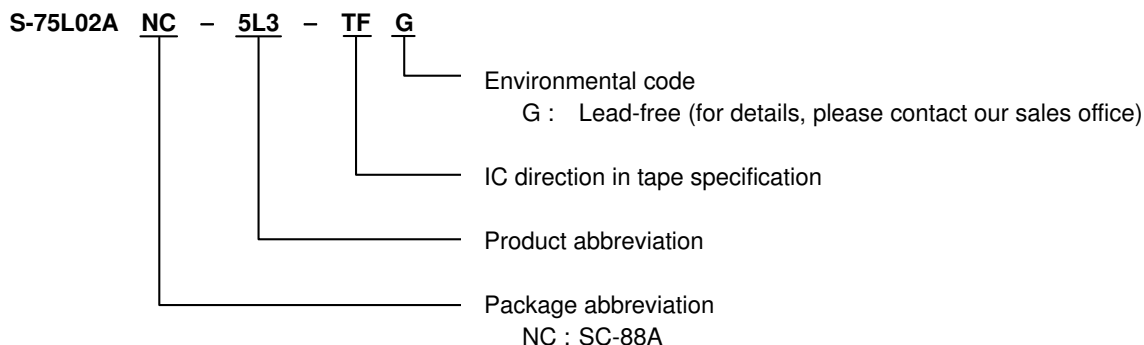

■ Absolute Maximum Ratings

(Ta = 25°C unless otherwise specified)

| Item | Symbol | Absolute Maximum Ratings | Unit |
|--------------------------------|-----------|---------------------------------|------|
| Power supply voltage | V_{CC} | -0.5 to +5.0 | V |
| Input voltage | V_{IN} | -0.5 to +5.0 | V |
| Output voltage | V_{OUT} | -0.5 to $V_{CC} + 0.5$ | V |
| Input parasitic diode current | I_{IK} | -20 | mA |
| Output parasitic diode current | I_{OK} | ±20 | mA |
| Output current | I_{OUT} | ±12.5 | mA |
| V_{CC}/GND current | I_{CC} | ±25 | mA |
| Power dissipation | P_D | 200 (When not mounted on board) | mW |
| | | 350*1 | mW |
| Operating ambient temperature | T_{opr} | -40 to +85 | °C |
| Storage temperature | T_{stg} | -65 to +150 | °C |
| Lead temperature (10 s) | T_L | 260 | °C |

*1. When mounted on board
[Mounted board]

- (1) Board size : 114.3 mm × 76.2 mm × t1.6 mm
- (2) Board name : JEDEC STANDARD51-7

Caution The absolute maximum ratings are rated values exceeding which the product could suffer physical damage. These values must therefore not be exceeded under any conditions.

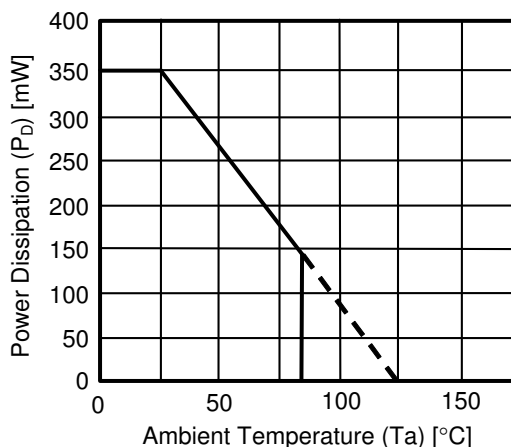

Power Dissipation of Package (When Mounted on Board)

■ Recommended Operating Conditions

| Item | Symbol | Standard | Unit |
|------------------------|------------|-------------------------------|------|
| Power voltage | V_{CC} | 1 to 3.6 | V |
| Input voltage | V_{IN} | 0 to 3.6 | V |
| Output voltage | V_{OUT} | 0 to V_{CC} | V |
| Input rise / fall time | t_R, t_F | 0 to 1000 ($V_{CC} = 1.0$ V) | ns |
| | | 0 to 500 ($V_{CC} = 2.0$ V) | ns |
| | | 0 to 400 ($V_{CC} = 3.0$ V) | ns |

■ DC Electrical Characteristics

| Item | Symbol | Conditions | $T_a = 25^\circ\text{C}$ | | | $T_a = -40$ to 85°C | | Unit | | | |
|---------------------|-----------|--------------------------|----------------------------------|----------------------------|------|-----------------------------------|------|-----------|---------------|------|---|
| | | | V_{CC} | Min. | Typ. | Max. | Min. | | Max. | | |
| Input voltage | "H" level | V_{IH} | — | 1.0 | 0.75 | — | — | 0.75 | — | V | |
| | | | | 1.5 | 1.05 | — | — | 1.05 | — | V | |
| | | | | 3.0 | 2.10 | — | — | 2.10 | — | V | |
| | "L" level | V_{IL} | — | 1.0 | — | — | 0.25 | — | 0.25 | V | |
| | | | | 1.5 | — | — | 0.45 | — | 0.45 | V | |
| | | | | 3.0 | — | — | 0.90 | — | 0.90 | V | |
| Output voltage | "H" level | V_{OH} | $V_{IN} = V_{IL}$ | $I_{OH} = -20 \mu\text{A}$ | 1.0 | 0.9 | 1.0 | — | 0.9 | — | V |
| | | | | | 1.5 | 1.4 | 1.5 | — | 1.4 | — | V |
| | | | | | 3.0 | 2.9 | 3.0 | — | 2.9 | — | V |
| | | | | $I_{OH} = -1 \text{ mA}$ | 1.5 | 1.07 | 1.23 | — | 0.99 | — | V |
| | | | | | 3.0 | 2.61 | 2.68 | — | 2.55 | — | V |
| | | | | | | | | — | — | — | V |
| | "L" level | V_{OL} | $V_{IN} = V_{IL}$ or V_{IH} | $I_{OL} = 20 \mu\text{A}$ | 1.0 | — | 0 | 0.1 | — | 0.1 | V |
| | | | | | 1.5 | — | 0 | 0.1 | — | 0.1 | V |
| | | | | | 3.0 | — | 0 | 0.1 | — | 0.1 | V |
| | | | | $I_{OL} = 1 \text{ mA}$ | 1.5 | — | 0.23 | 0.31 | — | 0.37 | V |
| | | | | | 3.0 | — | 0.23 | 0.31 | — | 0.33 | V |
| | | | | | | | | | — | — | — |
| Input current | I_{IN} | $V_{IN} = V_{CC}$ or GND | 3.6 | — | — | ± 0.1 | — | ± 1.0 | μA | | |
| Current consumption | I_{CC} | $V_{IN} = V_{CC}$ or GND | 3.6 | — | — | 1.0 | — | 10.0 | μA | | |

■ AC Electrical Characteristics

($C_L = 15$ pf, Input $t_R = t_F = 6$ ns, $V_{CC} = 3.3 \pm 0.3$ V, $T_a = 25^\circ\text{C}$ unless otherwise specified)

| Item | Symbol | Measurement Conditions | Min. | Typ. | Max. | Unit |
|-------------------------|--------------------------|------------------------|------|------|------|------|
| Output rise / fall time | t_{TLH} , t_{THL} | — | — | 4.0 | 8.0 | ns |
| Propagation delay time | t_{PLH} , t_{PHL} | — | — | 6.0 | 9.0 | ns |

($C_L = 25$ pf, Input $t_R = t_F = 6$ ns unless otherwise specified)

| Item | Symbol | Measurement Conditions | $T_a = 25^\circ\text{C}$ | | | $T_a = -40$ to 85°C | | Unit | |
|---------------------------------|--------------------------|------------------------|--------------------------|------|------|-----------------------------------|------|------|------|
| | | | V_{CC} (V) | Min. | Typ. | Max. | Min. | | Max. |
| Output rise / fall time | t_{TLH} , t_{THL} | — | 1.0 | — | 35 | 70 | — | 90 | ns |
| | | | 1.5 | — | 15 | 25 | — | 30 | ns |
| | | | 3.0 | — | 7 | 10 | — | 14 | ns |
| Propagation delay time | t_{PLH} , t_{PHL} | — | 1.0 | — | 30 | 60 | — | 75 | ns |
| | | | 1.5 | — | 15 | 25 | — | 30 | ns |
| | | | 3.0 | — | 7 | 10 | — | 14 | ns |
| Input capacitance | C_{IN} | — | — | 5 | 10 | — | 10 | pF | |
| Equivalent internal capacitance | C_{PD}^{*1} | — | — | 10 | — | — | — | pF | |

*1. C_{PD} is the no-load equivalent capacitance inside the circuitry. Refer to the measurement circuit shown below.
 Current consumption is averaged by the following equation.

$$I_{CC(opr)} = C_{PD} \times V_{CC} \times fin + I_{CC}$$

Measurement Circuit

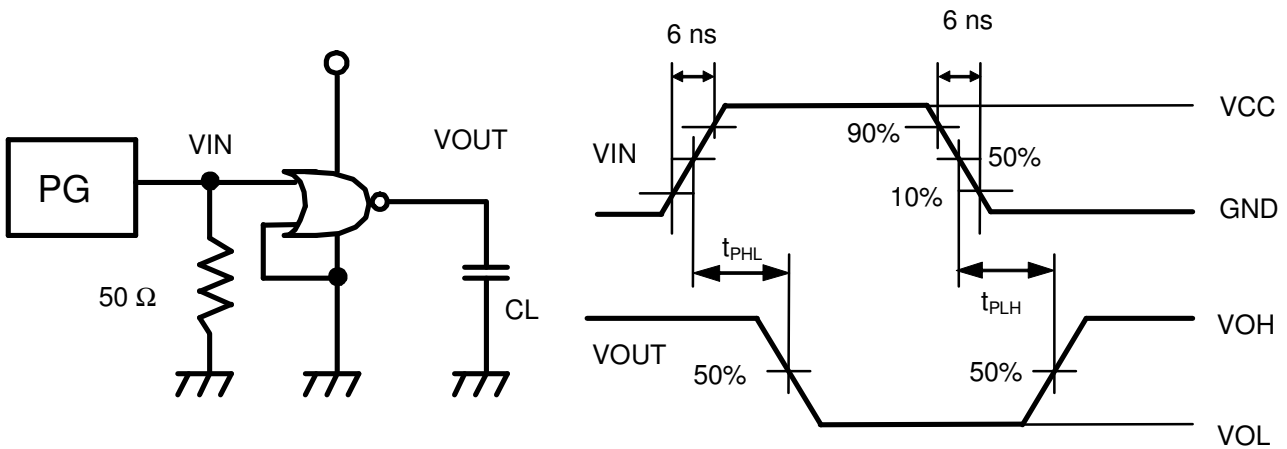

Remark No-load output during measurement of current consumption.

■ Input Pin Equivalent Circuit

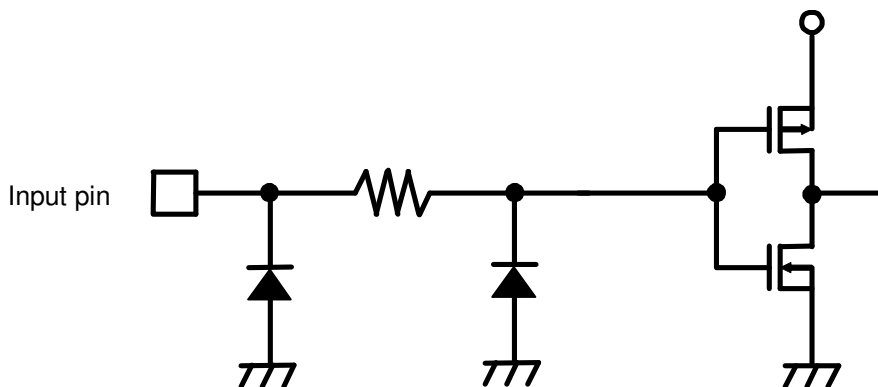

The S-75L04ANC is an inverter fabricated by utilizing advanced silicon-gate CMOS technology which provides the inherent benefit of CMOS low power consumption to achieve operation by only a couple of batteries (1 to 3 V).

The internal circuitry has buffered outputs to ensure high noise immunity and output stability.

Input voltage is allowed to be applied even if power voltage is not supplied because no diode is inserted between an input pin and V_{CC} .

This allows for interfaces between power supplies of different voltage, output level conversion from 3 V to 1 V and battery backup applications.

■ Features

- Wide power supply range: 1 V to 3.6 V
- Low current consumption: 1.0 μ A max. (at 3.6 V, 25°C)
- Typical propagation delay: $t_{PD} = 7$ ns (at 3 V)
- High noise immunity: $V_{NIH} = V_{NIL} = 28\% V_{CC}$ min.
- Power down protection: All pins
- Lead-free

■ Applications

- Personal computers, peripherals
- Cellular phones
- Cameras
- Games

■ Package

- SC-88A

■ Pin Configuration

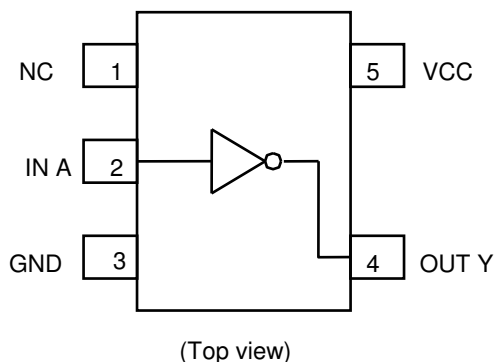

■ Marking Specification

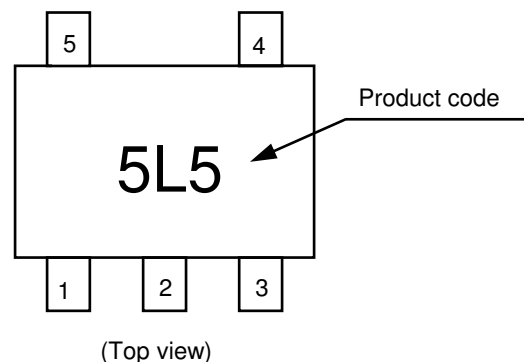

■ Logic Diagram

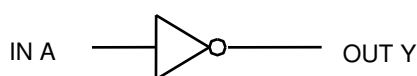

True values

| A | Y |
|---|---|
| L | H |
| H | L |

■ Product Name Structure

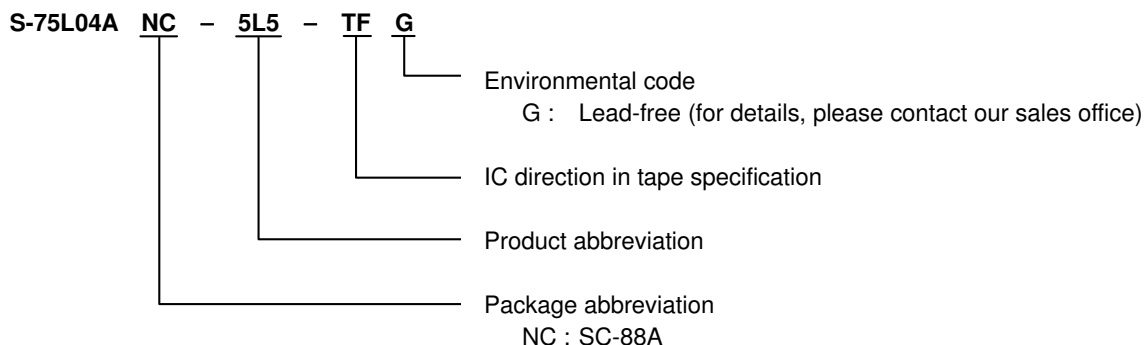

■ Absolute Maximum Ratings

(Ta = 25°C unless otherwise specified)

| Item | Symbol | Absolute Maximum Ratings | Unit |
|--------------------------------|-----------|---------------------------------|------|
| Power supply voltage | V_{CC} | -0.5 to +5.0 | V |
| Input voltage | V_{IN} | -0.5 to +5.0 | V |
| Output voltage | V_{OUT} | -0.5 to $V_{CC} + 0.5$ | V |
| Input parasitic diode current | I_{IK} | -20 | mA |
| Output parasitic diode current | I_{OK} | ±20 | mA |
| Output current | I_{OUT} | ±12.5 | mA |
| V_{CC} /GND current | I_{CC} | ±25 | mA |
| Power dissipation | P_D | 200 (When not mounted on board) | mW |
| | | 350 ^{*1} | mW |
| Operating ambient temperature | T_{opr} | -40 to +85 | °C |
| Storage temperature | T_{stg} | -65 to +150 | °C |
| Lead temperature (10 s) | T_L | 260 | °C |

*1. When mounted on board
[Mounted board]

- (1) Board size : 114.3 mm × 76.2 mm × t1.6 mm
- (2) Board name : JEDEC STANDARD51-7

Caution The absolute maximum ratings are rated values exceeding which the product could suffer physical damage. These values must therefore not be exceeded under any conditions.

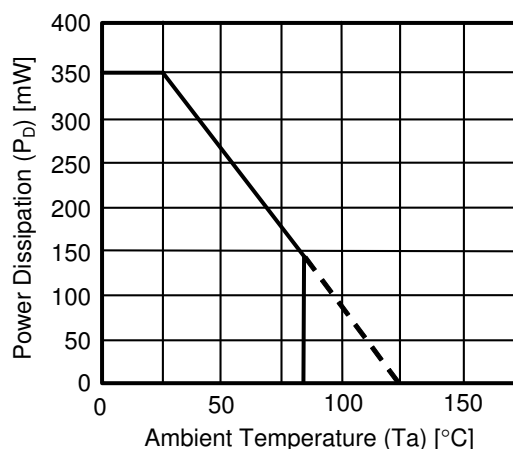

Power Dissipation of Package (When Mounted on Board)

■ Recommended Operating Conditions

| Item | Symbol | Standard | Unit |
|------------------------|------------|-------------------------------|------|
| Power voltage | V_{CC} | 1 to 3.6 | V |
| Input voltage | V_{IN} | 0 to 3.6 | V |
| Output voltage | V_{OUT} | 0 to V_{CC} | V |
| Input rise / fall time | t_R, t_F | 0 to 1000 ($V_{CC} = 1.0$ V) | ns |
| | | 0 to 500 ($V_{CC} = 2.0$ V) | ns |
| | | 0 to 400 ($V_{CC} = 3.0$ V) | ns |

■ DC Electrical Characteristics

| Item | Symbol | Conditions | $T_a = 25^\circ\text{C}$ | | | $T_a = -40$ to 85°C | | Unit | | | |
|---------------------|-----------|--------------------------|--------------------------|----------------------------|----------------------------|-----------------------------------|------|-----------|---------------|------|------|
| | | | V_{CC} | Min. | Typ. | Max. | Min. | | Max. | | |
| Input voltage | "H" level | V_{IH} | — | 1.0 | 0.75 | — | — | 0.75 | — | V | |
| | | | | 1.5 | 1.05 | — | — | 1.05 | — | V | |
| | | | | 3.0 | 2.10 | — | — | 2.10 | — | V | |
| | "L" level | V_{IL} | — | 1.0 | — | — | 0.25 | — | 0.25 | V | |
| | | | | 1.5 | — | — | 0.45 | — | 0.45 | V | |
| | | | | 3.0 | — | — | 0.90 | — | 0.90 | V | |
| Output voltage | "H" level | V_{OH} | $V_{IN} = V_{IL}$ | $I_{OH} = -20 \mu\text{A}$ | 1.0 | 0.9 | 1.0 | — | 0.9 | — | V |
| | | | | | 1.5 | 1.4 | 1.5 | — | 1.4 | — | V |
| | | | | | 3.0 | 2.9 | 3.0 | — | 2.9 | — | V |
| | | | | $I_{OH} = -1 \text{ mA}$ | 1.5 | 1.07 | 1.23 | — | 0.99 | — | V |
| | | | | | 3.0 | 2.61 | 2.68 | — | 2.55 | — | V |
| | | | | | $I_{OH} = -2.6 \text{ mA}$ | 3.0 | 2.61 | 2.68 | — | 2.55 | — |
| | "L" level | V_{OL} | $V_{IN} = V_{IH}$ | $I_{OL} = 20 \mu\text{A}$ | 1.0 | — | 0 | 0.1 | — | 0.1 | V |
| | | | | | 1.5 | — | 0 | 0.1 | — | 0.1 | V |
| | | | | | 3.0 | — | 0 | 0.1 | — | 0.1 | V |
| | | | | $I_{OL} = 1 \text{ mA}$ | 1.5 | — | 0.23 | 0.31 | — | 0.37 | V |
| | | | | | 3.0 | — | 0.23 | 0.31 | — | 0.33 | V |
| | | | | | $I_{OL} = 2.6 \text{ mA}$ | 3.0 | — | 0.23 | 0.31 | — | 0.33 |
| Input current | I_{IN} | $V_{IN} = V_{CC}$ or GND | 3.6 | — | — | ± 0.1 | — | ± 1.0 | μA | | |
| Current consumption | I_{CC} | $V_{IN} = V_{CC}$ or GND | 3.6 | — | — | 1.0 | — | 10.0 | μA | | |

■ AC Electrical Characteristics

($C_L = 15$ pf, Input $t_R = t_F = 6$ ns, $V_{CC} = 3.3 \pm 0.3$ V, $T_a = 25^\circ\text{C}$ unless otherwise specified)

| Item | Symbol | Measurement Conditions | Min. | Typ. | Max. | Unit |
|-------------------------|--------------------------|------------------------|------|------|------|------|
| Output rise / fall time | t_{TLH} , t_{THL} | — | — | 4.0 | 8.0 | ns |
| Propagation delay time | t_{PLH} , t_{PHL} | — | — | 6.0 | 9.0 | ns |

($C_L = 25$ pf, Input $t_R = t_F = 6$ ns unless otherwise specified)

| Item | Symbol | Measurement Conditions | $T_a = 25^\circ\text{C}$ | | | $T_a = -40$ to 85°C | | Unit | |
|---------------------------------|--------------------------|------------------------|--------------------------|------|------|-----------------------------------|------|------|------|
| | | | V_{CC} (V) | Min. | Typ. | Max. | Min. | | Max. |
| Output rise / fall time | t_{TLH} , t_{THL} | — | 1.0 | — | 35 | 70 | — | 90 | ns |
| | | | 1.5 | — | 15 | 25 | — | 30 | ns |
| | | | 3.0 | — | 7 | 10 | — | 14 | ns |
| Propagation delay time | t_{PLH} , t_{PHL} | — | 1.0 | — | 30 | 60 | — | 75 | ns |
| | | | 1.5 | — | 15 | 25 | — | 30 | ns |
| | | | 3.0 | — | 7 | 10 | — | 14 | ns |
| Input capacitance | C_{IN} | — | — | 5 | 10 | — | 10 | pF | |
| Equivalent internal capacitance | C_{PD}^{*1} | — | — | 10 | — | — | — | pF | |

*1. C_{PD} is the no-load equivalent capacitance inside the circuitry. Refer to the measurement circuit shown below. Current consumption is averaged by the following equation.

$$I_{CC(opr)} = C_{PD} \times V_{CC} \times fin + I_{CC}$$

Measurement Circuit

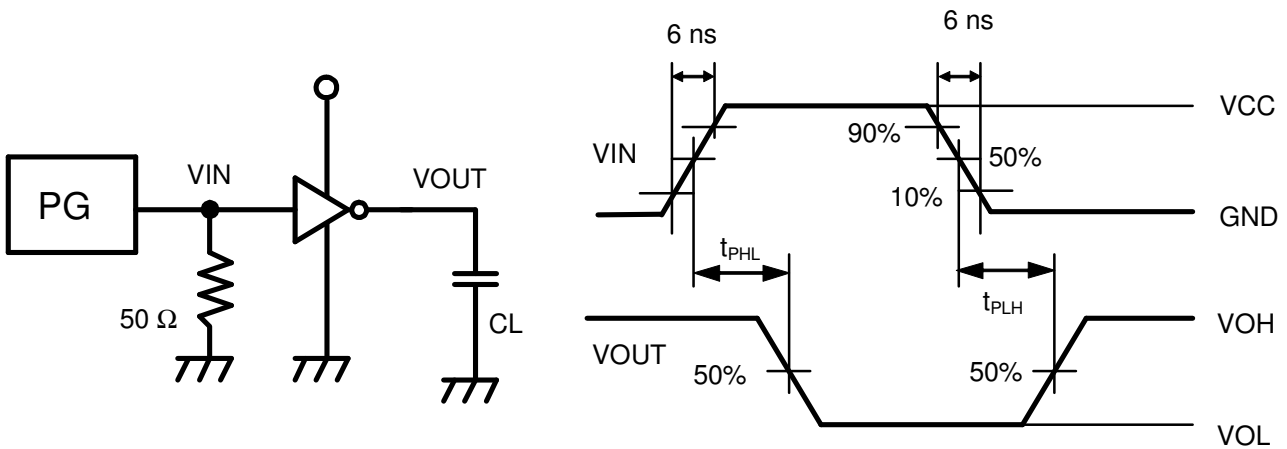

Remark No-load output during measurement of current consumption.

■ Input Pin Equivalent Circuit

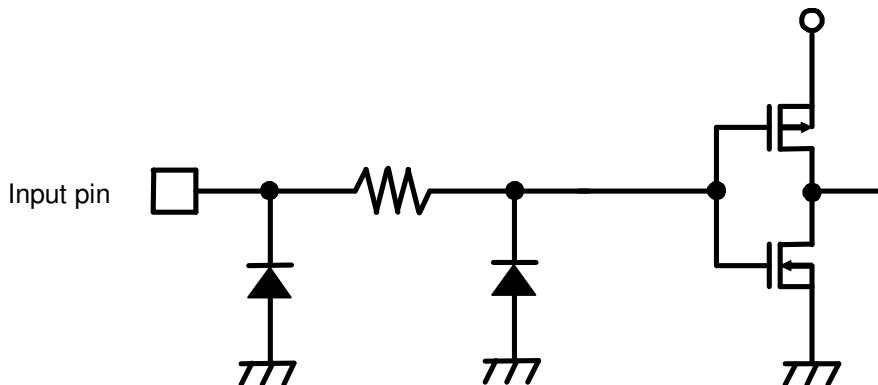

The S-75LU04ANC is a single packaged inverter without buffer fabricated by utilizing advanced silicon-gate CMOS technology which provides the inherent benefit of CMOS low power consumption to achieve operation by only a couple of batteries (1 to 3 V).

The S-75LU04ANC is suitable for a wide variety of linear circuits.

Input voltage is allowed to be applied even if power voltage is not supplied because no diode is inserted between an input pin and V_{CC} .

This allows for interfaces between power supplies of different voltage, output level conversion from 3 V to 1 V and battery backup applications.

■ Features

- Wide power supply range: 1 V to 3.6 V
- Low current consumption: 1.0 μ A max. (at 3.6 V, 25°C)
- Typical propagation delay: $t_{PD} = 6$ ns (at 3 V)
- High noise immunity: $V_{NIH} = V_{NIL} = 10\% V_{CC}$ min.
- Power down protection: All pins
- Lead-free

■ Applications

- Personal computers, peripherals
- Cellular phones
- Cameras
- Games

■ Package

- SC-88A

■ Pin Configuration

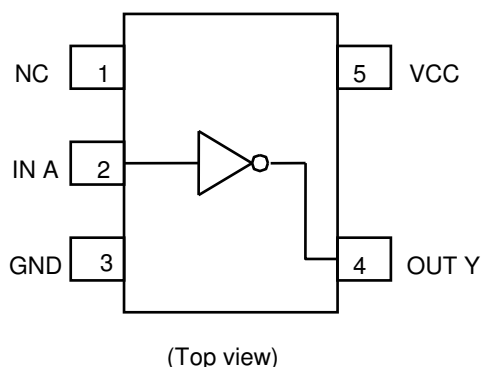

■ Marking Specification

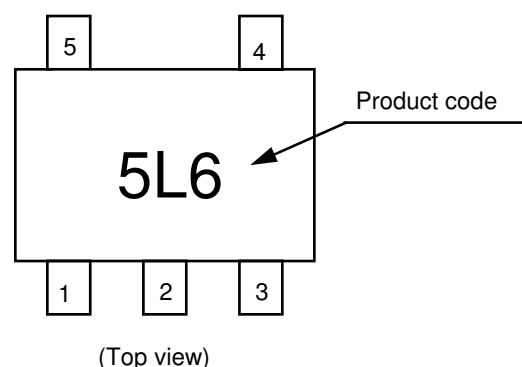

■ Logic Diagram

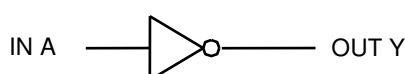

True values

| A | Y |
|---|---|
| L | H |
| H | L |

■ **Product Name Structure**

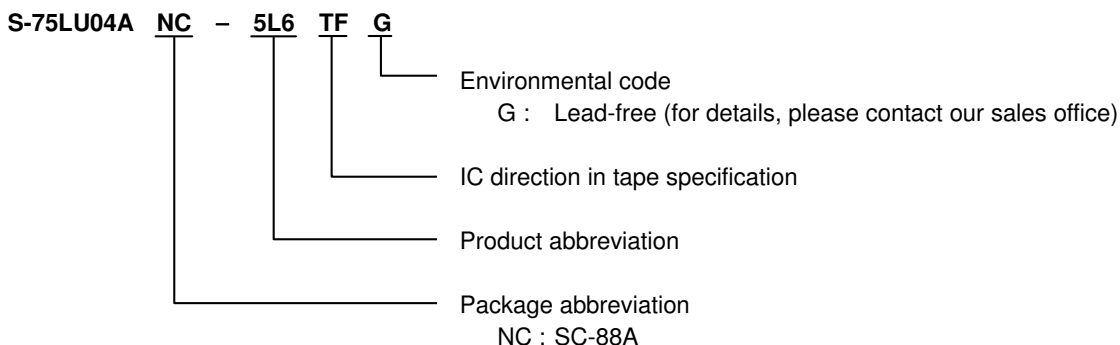

■ **Absolute Maximum Ratings**

(Ta = 25°C unless otherwise specified)

| Item | Symbol | Absolute Maximum Ratings | Unit |
|--------------------------------|------------------|---------------------------------|------|
| Power supply voltage | V _{CC} | -0.5 to +5.0 | V |
| Input voltage | V _{IN} | -0.5 to +5.0 | V |
| Output voltage | V _{OUT} | -0.5 to V _{CC} + 0.5 | V |
| Input parasitic diode current | I _{IK} | -20 | mA |
| Output parasitic diode current | I _{OK} | ±20 | mA |
| Output current | I _{OUT} | ±12.5 | mA |
| V _{CC} /GND current | I _{CC} | ±25 | mA |
| Power dissipation | P _D | 200 (When not mounted on board) | mW |
| | | 350*1 | mW |
| Operating ambient temperature | T _{opr} | -40 to +85 | °C |
| Storage temperature | T _{stg} | -65 to +150 | °C |
| Lead temperature (10 s) | T _L | 260 | °C |

- *1. When mounted on board
 [Mounted board]
 (1) Board size : 114.3 mm × 76.2 mm × t1.6 mm
 (2) Board name : JEDEC STANDARD51-7

Caution The absolute maximum ratings are rated values exceeding which the product could suffer physical damage. These values must therefore not be exceeded under any conditions.

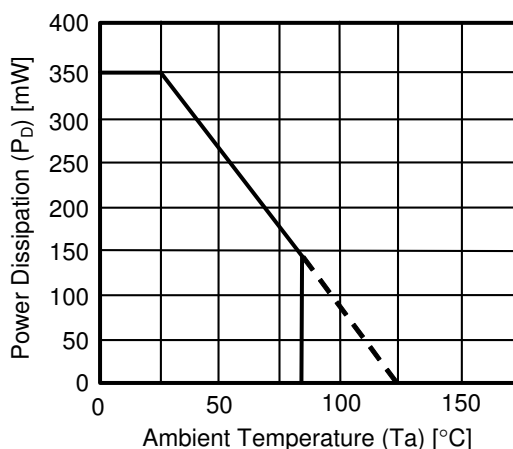

Power Dissipation of Package (When Mounted on Board)

■ Recommended Operating Conditions

| Item | Symbol | Standard | Unit |
|------------------------|------------|-------------------------------|------|
| Power voltage | V_{CC} | 1 to 3.6 | V |
| Input voltage | V_{IN} | 0 to 3.6 | V |
| Output voltage | V_{OUT} | 0 to V_{CC} | V |
| Input rise / fall time | t_R, t_F | 0 to 1000 ($V_{CC} = 1.0$ V) | ns |
| | | 0 to 500 ($V_{CC} = 2.0$ V) | ns |
| | | 0 to 400 ($V_{CC} = 3.0$ V) | ns |

■ DC Electrical Characteristics

| Item | Symbol | Conditions | $T_a = 25^\circ\text{C}$ | | | $T_a = -40$ to 85°C | | Unit | | | |
|---------------------|-----------|--------------------------|--------------------------|----------------------------|----------------------------|-----------------------------------|------|-----------|---------------|------|------|
| | | | V_{CC} | Min. | Typ. | Max. | Min. | | Max. | | |
| Input voltage | "H" level | V_{IH} | — | 1.0 | 0.75 | — | — | 0.75 | — | V | |
| | | | | 1.5 | 1.05 | — | — | 1.05 | — | V | |
| | | | | 3.0 | 2.10 | — | — | 2.10 | — | V | |
| | "L" level | V_{IL} | — | 1.0 | — | — | 0.25 | — | 0.25 | V | |
| | | | | 1.5 | — | — | 0.45 | — | 0.45 | V | |
| | | | | 3.0 | — | — | 0.90 | — | 0.90 | V | |
| Output voltage | "H" level | V_{OH} | $V_{IN} = V_{IL}$ | $I_{OH} = -20 \mu\text{A}$ | 1.0 | 0.9 | 1.0 | — | 0.9 | — | V |
| | | | | | 1.5 | 1.4 | 1.5 | — | 1.4 | — | V |
| | | | | | 3.0 | 2.9 | 3.0 | — | 2.9 | — | V |
| | | | | $I_{OH} = -1 \text{ mA}$ | 1.5 | 1.07 | 1.23 | — | 0.99 | — | V |
| | | | | | 3.0 | 2.61 | 2.68 | — | 2.55 | — | V |
| | | | | | $I_{OH} = -2.6 \text{ mA}$ | 3.0 | 2.61 | 2.68 | — | 2.55 | — |
| | "L" level | V_{OL} | $V_{IN} = V_{IH}$ | $I_{OL} = 20 \mu\text{A}$ | 1.0 | — | 0 | 0.1 | — | 0.1 | V |
| | | | | | 1.5 | — | 0 | 0.1 | — | 0.1 | V |
| | | | | | 3.0 | — | 0 | 0.1 | — | 0.1 | V |
| | | | | $I_{OL} = 1 \text{ mA}$ | 1.5 | — | 0.23 | 0.31 | — | 0.37 | V |
| | | | | | 3.0 | — | 0.23 | 0.31 | — | 0.33 | V |
| | | | | | $I_{OL} = 2.6 \text{ mA}$ | 3.0 | — | 0.23 | 0.31 | — | 0.33 |
| Input current | I_{IN} | $V_{IN} = V_{CC}$ or GND | 3.6 | — | — | ± 0.1 | — | ± 1.0 | μA | | |
| Current consumption | I_{CC} | $V_{IN} = V_{CC}$ or GND | 3.6 | — | — | 1.0 | — | 10.0 | μA | | |

■ AC Electrical Characteristics

($C_L = 15$ pf, Input $t_R = t_F = 6$ ns, $V_{CC} = 3.3 \pm 0.3$ V, $T_a = 25^\circ\text{C}$ unless otherwise specified)

| Item | Symbol | Measurement Conditions | Min. | Typ. | Max. | Unit |
|-------------------------|--------------------------|------------------------|------|------|------|------|
| Output rise / fall time | t_{TLH} , t_{THL} | — | — | 6.0 | 9.0 | ns |
| Propagation delay time | t_{PLH} , t_{PHL} | — | — | 4.0 | 10.0 | ns |

($C_L = 25$ pf, Input $t_R = t_F = 6$ ns unless otherwise specified)

| Item | Symbol | Measurement Conditions | $T_a = 25^\circ\text{C}$ | | | $T_a = -40$ to 85°C | | Unit | |
|---------------------------------|--------------------------|------------------------|--------------------------|------|------|-----------------------------------|------|------|------|
| | | | V_{CC} (V) | Min. | Typ. | Max. | Min. | | Max. |
| Output rise / fall time | t_{TLH} , t_{THL} | — | 1.0 | — | 35 | 70 | — | 90 | ns |
| | | | 1.5 | — | 15 | 25 | — | 30 | ns |
| | | | 3.0 | — | 7 | 10 | — | 14 | ns |
| Propagation delay time | t_{PLH} , t_{PHL} | — | 1.0 | — | 20 | 40 | — | 50 | ns |
| | | | 1.5 | — | 10 | 15 | — | 20 | ns |
| | | | 3.0 | — | 6 | 9 | — | 12 | ns |
| Input capacitance | C_{IN} | — | — | 5 | 10 | — | 10 | pF | |
| Equivalent internal capacitance | C_{PD}^{*1} | — | — | 10 | — | — | — | pF | |

*1. C_{PD} is the no-load equivalent capacitance inside the circuitry. Refer to the measurement circuit shown below. Current consumption is averaged by the following equation.

$$I_{CC(opr)} = C_{PD} \times V_{CC} \times fin + I_{CC}$$

Measurement Circuit

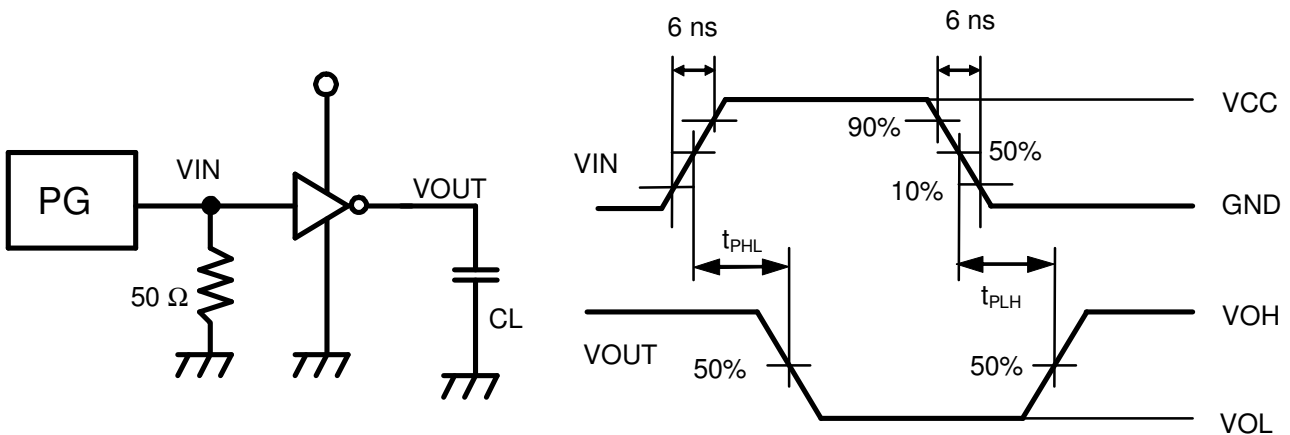

Remark No-load output during measurement of current consumption.

■ Input Pin Equivalent Circuit

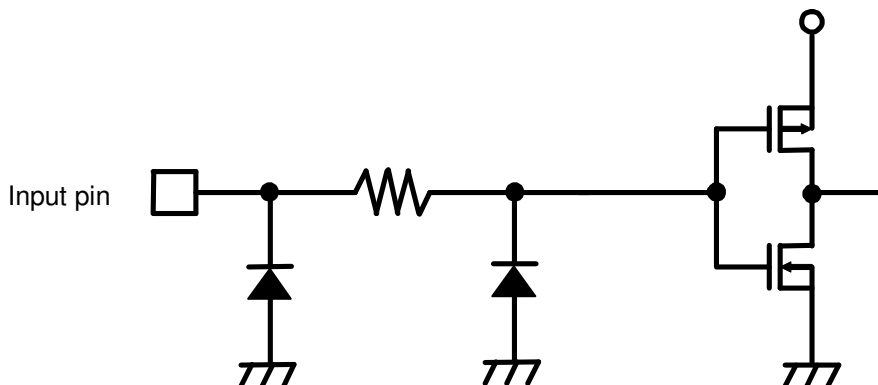

The S-75L08ANC is a single 2-Input AND Gate fabricated by utilizing advanced silicon-gate CMOS technology which provides the inherent benefit of CMOS low power consumption to achieve operation by only a couple of batteries (1 to 3 V). The internal circuitry has buffered outputs to ensure high noise immunity and output stability.

Input voltage is allowed to be applied even if power voltage is not supplied because no diode is inserted between an input pin and V_{CC} .

This allows for interfaces between power supplies of different voltage, output level conversion from 3 V to 1 V and battery backup applications.

■ Features

- Wide power supply range: 1 V to 3.6 V
- Low current consumption: 1.0 μ A max. (at 3.6 V, 25°C)
- Typical propagation delay: $t_{PD} = 7$ ns (at 3 V)
- High noise immunity: $V_{NIH} = V_{NIL} = 28\% V_{CC}$ min.
- Power down protection: All pins
- Lead-free

■ Applications

- Personal computers, peripherals
- Cellular phones
- Cameras
- Games

■ Package

- SC-88A

■ Pin Configuration

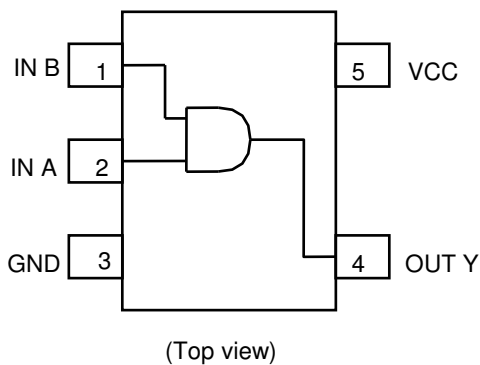

■ Marking Specification

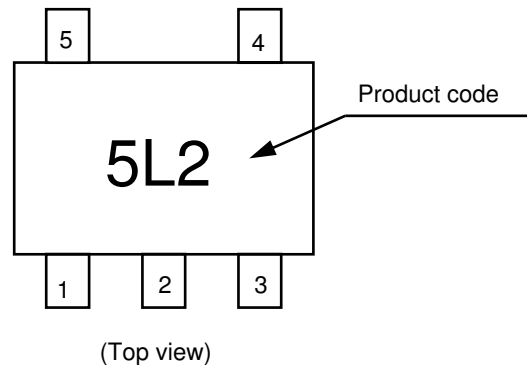

■ Logic Diagram

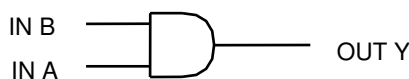

True values

| A | B | Y |
|---|---|---|
| L | L | L |
| L | H | L |
| H | L | L |
| H | H | H |

■ Product Name Structure

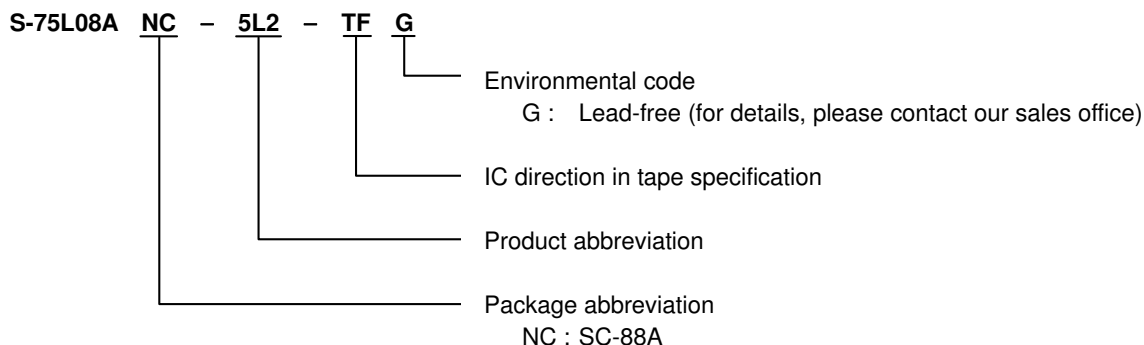

■ Absolute Maximum Ratings

(Ta = 25°C unless otherwise specified)

| Item | Symbol | Absolute Maximum Ratings | Unit |
|--------------------------------|-----------|---------------------------------|------|
| Power supply voltage | V_{CC} | -0.5 to +5.0 | V |
| Input voltage | V_{IN} | -0.5 to +5.0 | V |
| Output voltage | V_{OUT} | -0.5 to $V_{CC} + 0.5$ | V |
| Input parasitic diode current | I_{IK} | -20 | mA |
| Output parasitic diode current | I_{OK} | ±20 | mA |
| Output current | I_{OUT} | ±12.5 | mA |
| V_{CC}/GND current | I_{CC} | ±25 | mA |
| Power dissipation | P_D | 200 (When not mounted on board) | mW |
| | | 350*1 | mW |
| Operating ambient temperature | T_{opr} | -40 to +85 | °C |
| Storage temperature | T_{stg} | -65 to +150 | °C |
| Lead temperature (10 s) | T_L | 260 | °C |

*1. When mounted on board
[Mounted board]

- (1) Board size : 114.3 mm × 76.2 mm × t1.6 mm
- (2) Board name : JEDEC STANDARD51-7

Caution The absolute maximum ratings are rated values exceeding which the product could suffer physical damage. These values must therefore not be exceeded under any conditions.

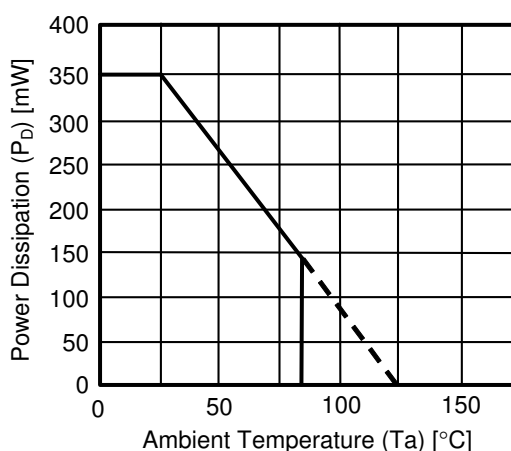

Power Dissipation of Package (When Mounted on Board)

■ Recommended Operating Conditions

| Item | Symbol | Standard | Unit |
|------------------------|------------|-------------------------------|------|
| Power voltage | V_{CC} | 1 to 3.6 | V |
| Input voltage | V_{IN} | 0 to 3.6 | V |
| Output voltage | V_{OUT} | 0 to V_{CC} | V |
| Input rise / fall time | t_R, t_F | 0 to 1000 ($V_{CC} = 1.0$ V) | ns |
| | | 0 to 500 ($V_{CC} = 2.0$ V) | ns |
| | | 0 to 400 ($V_{CC} = 3.0$ V) | ns |

■ DC Electrical Characteristics

| Item | Symbol | Conditions | $T_a = 25^\circ\text{C}$ | | | $T_a = -40$ to 85°C | | Unit | | | |
|---------------------|-----------|--------------------------|----------------------------------|----------------------------|------|-----------------------------------|------|-----------|---------------|------|---|
| | | | V_{CC} | Min. | Typ. | Max. | Min. | | Max. | | |
| Input voltage | "H" level | V_{IH} | — | 1.0 | 0.75 | — | — | 0.75 | — | V | |
| | | | | 1.5 | 1.05 | — | — | 1.05 | — | V | |
| | | | | 3.0 | 2.10 | — | — | 2.10 | — | V | |
| | "L" level | V_{IL} | — | 1.0 | — | — | 0.25 | — | 0.25 | V | |
| | | | | 1.5 | — | — | 0.45 | — | 0.45 | V | |
| | | | | 3.0 | — | — | 0.90 | — | 0.90 | V | |
| Output voltage | "H" level | V_{OH} | $V_{IN} = V_{IH}$ | $I_{OH} = -20 \mu\text{A}$ | 1.0 | 0.9 | 1.0 | — | 0.9 | — | V |
| | | | | | 1.5 | 1.4 | 1.5 | — | 1.4 | — | V |
| | | | | | 3.0 | 2.9 | 3.0 | — | 2.9 | — | V |
| | | | | $I_{OH} = -1 \text{ mA}$ | 1.5 | 1.07 | 1.23 | — | 0.99 | — | V |
| | | | | | 3.0 | 2.61 | 2.68 | — | 2.55 | — | V |
| | | | | | | | | | | | |
| | "L" level | V_{OL} | $V_{IN} = V_{IL}$ or V_{IH} | $I_{OL} = 20 \mu\text{A}$ | 1.0 | — | 0 | 0.1 | — | 0.1 | V |
| | | | | | 1.5 | — | 0 | 0.1 | — | 0.1 | V |
| | | | | | 3.0 | — | 0 | 0.1 | — | 0.1 | V |
| | | | | $I_{OL} = 1 \text{ mA}$ | 1.5 | — | 0.23 | 0.31 | — | 0.37 | V |
| | | | | | 3.0 | — | 0.23 | 0.31 | — | 0.33 | V |
| | | | | | | | | | | | |
| Input current | I_{IN} | $V_{IN} = V_{CC}$ or GND | 3.6 | — | — | ± 0.1 | — | ± 1.0 | μA | | |
| Current consumption | I_{CC} | $V_{IN} = V_{CC}$ or GND | 3.6 | — | — | 1.0 | — | 10.0 | μA | | |

■ AC Electrical Characteristics

($C_L = 15$ pf, Input $t_R = t_F = 6$ ns, $V_{CC} = 3.3 \pm 0.3$ V, $T_a = 25^\circ\text{C}$ unless otherwise specified)

| Item | Symbol | Measurement Conditions | Min. | Typ. | Max. | Unit |
|-------------------------|--------------------------|------------------------|------|------|------|------|
| Output rise / fall time | t_{TLH} , t_{THL} | — | — | 4.0 | 8.0 | ns |
| Propagation delay time | t_{PLH} , t_{PHL} | — | — | 6.0 | 9.0 | ns |

($C_L = 25$ pf, Input $t_R = t_F = 6$ ns unless otherwise specified)

| Item | Symbol | Measurement Conditions | $T_a = 25^\circ\text{C}$ | | | $T_a = -40$ to 85°C | | Unit | |
|---------------------------------|--------------------------|------------------------|--------------------------|------|------|-----------------------------------|------|------|------|
| | | | V_{CC} (V) | Min. | Typ. | Max. | Min. | | Max. |
| Output rise / fall time | t_{TLH} , t_{THL} | — | 1.0 | — | 35 | 70 | — | 90 | ns |
| | | | 1.5 | — | 15 | 25 | — | 30 | ns |
| | | | 3.0 | — | 7 | 10 | — | 14 | ns |
| Propagation delay time | t_{PLH} , t_{PHL} | — | 1.0 | — | 30 | 60 | — | 75 | ns |
| | | | 1.5 | — | 15 | 25 | — | 30 | ns |
| | | | 3.0 | — | 7 | 10 | — | 14 | ns |
| Input capacitance | C_{IN} | — | — | 5 | 10 | — | 10 | pF | |
| Equivalent internal capacitance | C_{PD}^{*1} | — | — | 10 | — | — | — | pF | |

*1. C_{PD} is the no-load equivalent capacitance inside the circuitry. Refer to the measurement circuit shown below. Current consumption is averaged by the following equation.

$$I_{CC(opr)} = C_{PD} \times V_{CC} \times fin + I_{CC}$$

Measurement Circuit

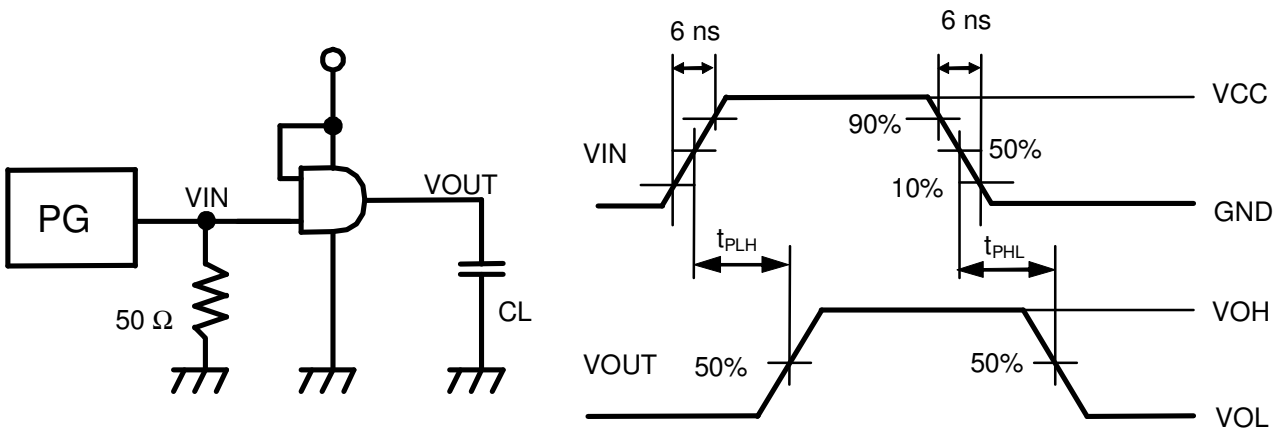

Remark No-load output during measurement of current consumption.

■ Input Pin Equivalent Circuit

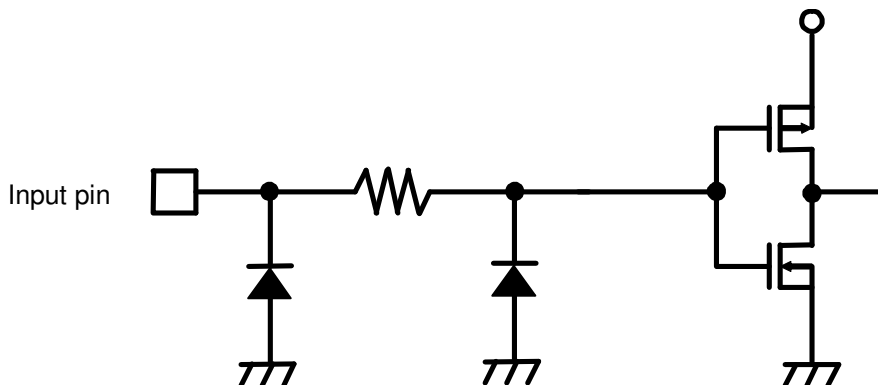

The S-75L14ANC is a SCHMITT INVERTER fabricated by utilizing advanced silicon-gate CMOS technology which provides the inherent benefit of CMOS low power consumption to achieve operation by only a couple of batteries (1 to 3 V).

The internal circuitry has buffered outputs to ensure high noise immunity and output stability.

Input voltage is allowed to be applied even if power voltage is not supplied because no diode is inserted between an input pin and V_{CC} .

This allows for interfaces between power supplies of different voltage, output level conversion from 3 V to 1 V and battery backup applications.

■ Features

- Wide power supply range: 1 V to 3.6 V
- Low current consumption: 1.0 μ A max. (at 3.6 V, 25°C)
- Typical propagation delay: $t_{PD} = 8$ ns (at 3 V)
- High noise immunity: $V_{NIH} = V_{NIL} = 28\% V_{CC}$ min.
- Power down protection: All pins
- Lead-free

■ Applications

- Personal computers, peripherals
- Cellular phones
- Cameras
- Games

■ Package

- SC-88A

■ Pin Configuration

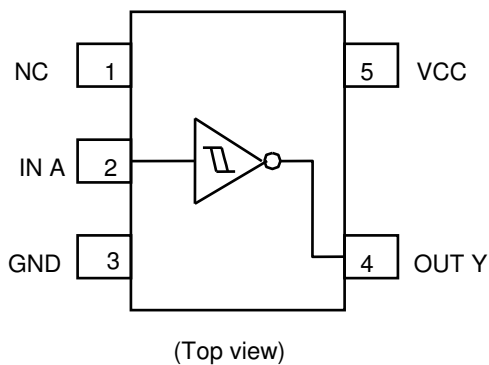

■ Marking Specification

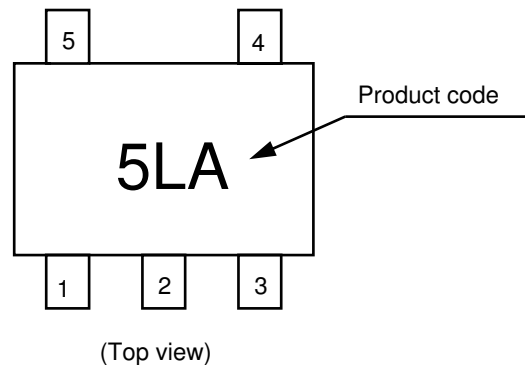

■ Logic Diagram

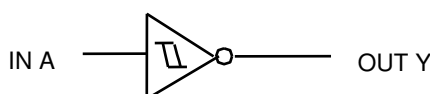

True values

| A | Y |
|---|---|
| L | H |
| H | L |

■ Product Name Structure

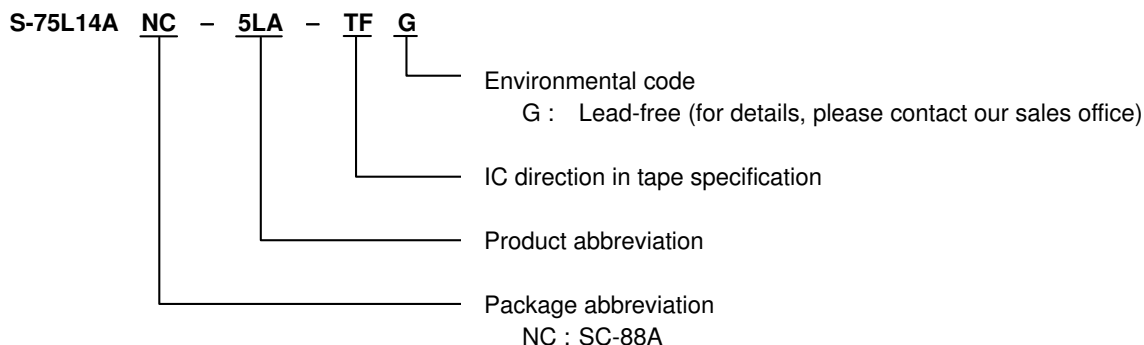

■ Absolute Maximum Ratings

(Ta = 25°C unless otherwise specified)

| Item | Symbol | Absolute Maximum Ratings | Unit |
|--------------------------------|-----------|---------------------------------|------|
| Power supply voltage | V_{CC} | -0.5 to +5.0 | V |
| Input voltage | V_{IN} | -0.5 to +5.0 | V |
| Output voltage | V_{OUT} | -0.5 to $V_{CC} + 0.5$ | V |
| Input parasitic diode current | I_{IK} | -20 | mA |
| Output parasitic diode current | I_{OK} | ±20 | mA |
| Output current | I_{OUT} | ±12.5 | mA |
| V_{CC}/GND current | I_{CC} | ±25 | mA |
| Power dissipation | P_D | 200 (When not mounted on board) | mW |
| | | 350*1 | mW |
| Operating ambient temperature | T_{opr} | -40 to +85 | °C |
| Storage temperature | T_{stg} | -65 to +150 | °C |
| Lead temperature (10 s) | T_L | 260 | °C |

*1. When mounted on board
[Mounted board]

- (1) Board size : 114.3 mm × 76.2 mm × t1.6 mm
- (2) Board name : JEDEC STANDARD51-7

Caution The absolute maximum ratings are rated values exceeding which the product could suffer physical damage. These values must therefore not be exceeded under any conditions.

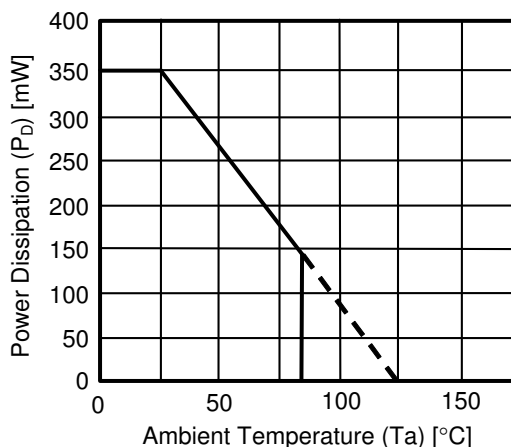

Power Dissipation of Package (When Mounted on Board)

■ Recommended Operating Conditions

| Item | Symbol | Standard | Unit |
|------------------------|------------|-------------------------------|------|
| Power voltage | V_{CC} | 1 to 3.6 | V |
| Input voltage | V_{IN} | 0 to 3.6 | V |
| Output voltage | V_{OUT} | 0 to V_{CC} | V |
| Input rise / fall time | t_R, t_F | 0 to 1000 ($V_{CC} = 1.0$ V) | ns |
| | | 0 to 500 ($V_{CC} = 2.0$ V) | ns |
| | | 0 to 400 ($V_{CC} = 3.0$ V) | ns |

■ DC Electrical Characteristics

| Item | Symbol | Conditions | $T_a = 25^\circ\text{C}$ | | | $T_a = -40$ to 85°C | | Unit | | | | |
|---------------------|-----------|--------------------------|--------------------------|----------------------------|------|-----------------------------------|------|-----------|---------------|------|---|---|
| | | | V_{CC} | Min. | Typ. | Max. | Min. | | Max. | | | |
| Input voltage | "H" level | V_{IH} | — | 1.0 | 0.80 | — | — | 0.80 | — | V | | |
| | | | | 1.5 | 1.20 | — | — | 1.20 | — | V | | |
| | | | | 3.0 | 2.10 | — | — | 2.10 | — | V | | |
| | "L" level | V_{IL} | — | 1.0 | — | — | 0.20 | — | 0.20 | V | | |
| | | | | 1.5 | — | — | 0.45 | — | 0.45 | V | | |
| | | | | 3.0 | — | — | 0.90 | — | 0.90 | V | | |
| Output voltage | "H" level | V_{OH} | $V_{IN} = V_{IL}$ | $I_{OH} = -20 \mu\text{A}$ | 1.0 | 0.9 | 1.0 | — | 0.9 | — | V | |
| | | | | | 1.5 | 1.4 | 1.5 | — | 1.4 | — | V | |
| | | | | | 3.0 | 2.9 | 3.0 | — | 2.9 | — | V | |
| | | | | $I_{OH} = -1 \text{ mA}$ | 1.5 | 1.07 | 1.23 | — | 0.99 | — | V | |
| | | | | | 3.0 | $I_{OH} = -2.6 \text{ mA}$ | 2.61 | 2.68 | — | 2.55 | — | V |
| | | | | | | | | | | | | |
| | "L" level | V_{OL} | $V_{IN} = V_{IH}$ | $I_{OL} = 20 \mu\text{A}$ | 1.0 | — | 0 | 0.1 | — | 0.1 | V | |
| | | | | | 1.5 | — | 0 | 0.1 | — | 0.1 | V | |
| | | | | | 3.0 | — | 0 | 0.1 | — | 0.1 | V | |
| | | | | $I_{OL} = 1 \text{ mA}$ | 1.5 | — | 0.23 | 0.31 | — | 0.37 | V | |
| | | | | | 3.0 | $I_{OL} = 2.6 \text{ mA}$ | 0.23 | 0.31 | — | 0.33 | V | |
| | | | | | | | | | | | | |
| Hysteresis Voltage | V_H | — | 1.0 | 0.20 | — | 0.50 | — | — | V | | | |
| | | | 1.5 | 0.25 | — | 0.50 | — | — | V | | | |
| | | | 3.0 | 0.45 | — | 0.65 | — | — | V | | | |
| Input current | I_{IN} | $V_{IN} = V_{CC}$ or GND | 3.6 | — | — | ± 0.1 | — | ± 1.0 | μA | | | |
| Current consumption | I_{CC} | $V_{IN} = V_{CC}$ or GND | 3.6 | — | — | 1.0 | — | 10.0 | μA | | | |

■ AC Electrical Characteristics

($C_L = 15$ pf, Input $t_R = t_F = 6$ ns, $V_{CC} = 3.3 \pm 0.3$ V, $T_a = 25^\circ\text{C}$ unless otherwise specified)

| Item | Symbol | Measurement Conditions | Min. | Typ. | Max. | Unit |
|-------------------------|--------------------------|------------------------|------|------|------|------|
| Output rise / fall time | t_{TLH} , t_{THL} | — | — | 4.0 | 8.0 | ns |
| Propagation delay time | t_{PLH} , t_{PHL} | — | — | 4.0 | 10.5 | ns |

($C_L = 25$ pf, Input $t_R = t_F = 6$ ns unless otherwise specified)

| Item | Symbol | Measurement Conditions | $T_a = 25^\circ\text{C}$ | | | $T_a = -40$ to 85°C | | Unit | |
|---------------------------------|--------------------------|------------------------|--------------------------|------|------|-----------------------------------|------|------|------|
| | | | V_{CC} (V) | Min. | Typ. | Max. | Min. | | Max. |
| Output rise / fall time | t_{TLH} , t_{THL} | — | 1.0 | — | 35 | 70 | — | 90 | ns |
| | | | 1.5 | — | 15 | 25 | — | 30 | ns |
| | | | 3.0 | — | 7 | 10 | — | 14 | ns |
| Propagation delay time | t_{PLH} , t_{PHL} | — | 1.0 | — | 35 | 70 | — | 90 | ns |
| | | | 1.5 | — | 15 | 25 | — | 30 | ns |
| | | | 3.0 | — | 8 | 12 | — | 15 | ns |
| Input capacitance | C_{IN} | — | — | 5 | 10 | — | 10 | pF | |
| Equivalent internal capacitance | C_{PD}^{*1} | — | — | 10 | — | — | — | pF | |

*1. C_{PD} is the no-load equivalent capacitance inside the circuitry. Refer to the measurement circuit shown below.
 Current consumption is averaged by the following equation.

$$I_{CC(opr)} = C_{PD} \times V_{CC} \times fin + I_{CC}$$

Measurement Circuit

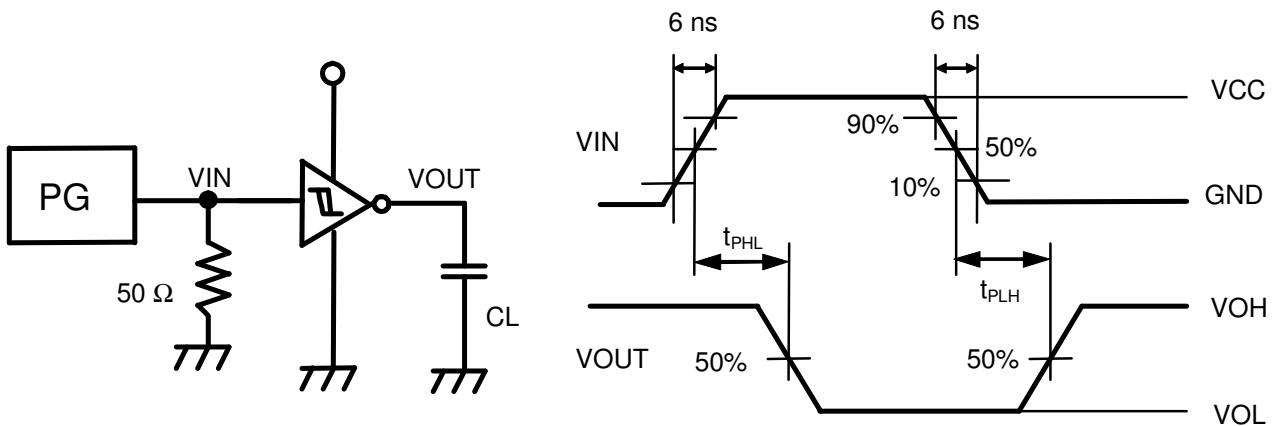

Remark No-load output during measurement of current consumption.

■ Input Pin Equivalent Circuit

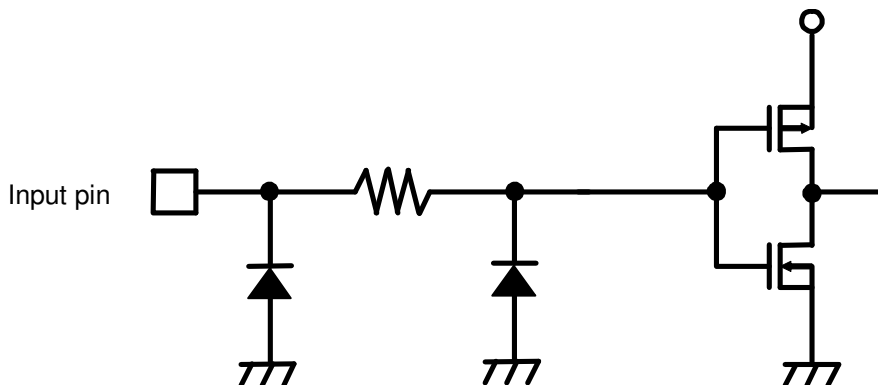

The S-75L32ANC is a single 2-input OR gate fabricated by utilizing advanced silicon-gate CMOS technology which provides the inherent benefit of CMOS low power consumption to achieve operation by only a couple of batteries (1 to 3 V).

The internal circuitry has buffered outputs to ensure high noise immunity and output stability.

Input voltage is allowed to be applied even if power voltage is not supplied because no diode is inserted between an input pin and V_{CC} .

This allows for interfaces between power supplies of different voltage, output level conversion from 3 V to 1 V and battery backup applications.

■ Features

- Wide power supply range: 1 V to 3.6 V
- Low current consumption: 1.0 μ A max. (at 3.6 V, 25°C)
- Typical propagation delay: $t_{PD} = 7$ ns (at 3 V)
- High noise immunity: $V_{NIH} = V_{NIL} = 28\% V_{CC}$ min.
- Power down protection: All pins
- Lead-free

■ Applications

- Personal computers, peripherals
- Cellular phones
- Cameras
- Games

■ Package

- SC-88A

■ Pin Configuration

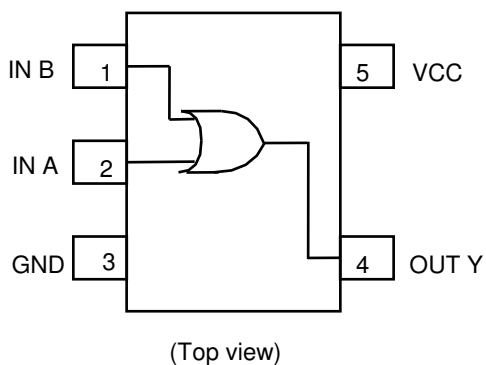

■ Marking Specification

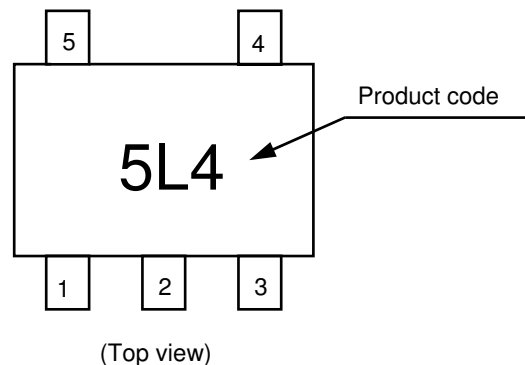

■ Logic Diagram

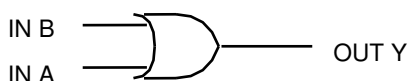

True values

| A | B | Y |
|---|---|---|
| L | L | L |
| L | H | H |
| H | L | H |
| H | H | H |

■ Product Name Structure

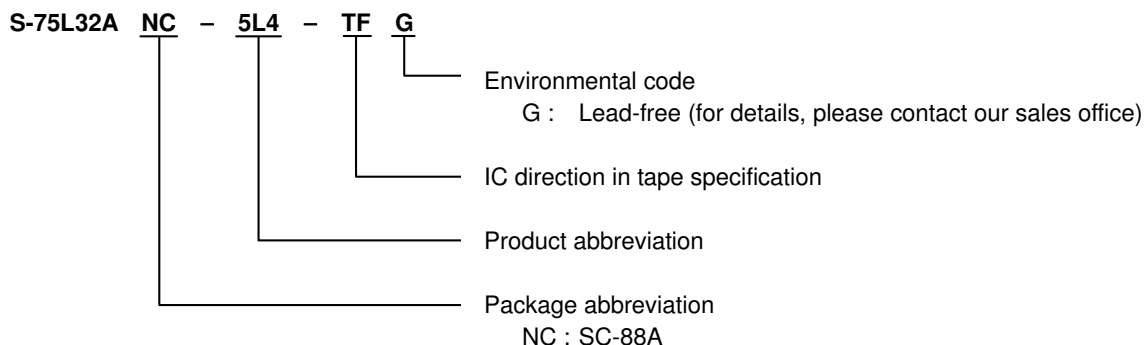

■ Absolute Maximum Ratings

(Ta = 25°C unless otherwise specified)

| Item | Symbol | Absolute Maximum Ratings | Unit |
|--------------------------------|-----------|---------------------------------|------|
| Power supply voltage | V_{CC} | -0.5 to +5.0 | V |
| Input voltage | V_{IN} | -0.5 to +5.0 | V |
| Output voltage | V_{OUT} | -0.5 to $V_{CC} + 0.5$ | V |
| Input parasitic diode current | I_{IK} | -20 | mA |
| Output parasitic diode current | I_{OK} | ±20 | mA |
| Output current | I_{OUT} | ±12.5 | mA |
| V_{CC}/GND current | I_{CC} | ±25 | mA |
| Power dissipation | P_D | 200 (When not mounted on board) | mW |
| | | 350*1 | mW |
| Operating ambient temperature | T_{opr} | -40 to +85 | °C |
| Storage temperature | T_{stg} | -65 to +150 | °C |
| Lead temperature (10 s) | T_L | 260 | °C |

*1. When mounted on board
[Mounted board]

- (1) Board size : 114.3 mm × 76.2 mm × t1.6 mm
- (2) Board name : JEDEC STANDARD51-7

Caution The absolute maximum ratings are rated values exceeding which the product could suffer physical damage. These values must therefore not be exceeded under any conditions.

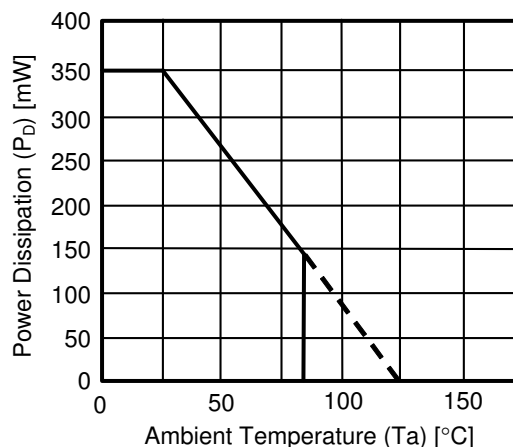

Power Dissipation of Package (When Mounted on Board)

■ Recommended Operating Conditions

| Item | Symbol | Standard | Unit |
|------------------------|------------|-------------------------------|------|
| Power voltage | V_{CC} | 1 to 3.6 | V |
| Input voltage | V_{IN} | 0 to 3.6 | V |
| Output voltage | V_{OUT} | 0 to V_{CC} | V |
| Input rise / fall time | t_R, t_F | 0 to 1000 ($V_{CC} = 1.0$ V) | ns |
| | | 0 to 500 ($V_{CC} = 2.0$ V) | ns |
| | | 0 to 400 ($V_{CC} = 3.0$ V) | ns |

■ DC Electrical Characteristics

| Item | Symbol | Conditions | $T_a = 25^\circ\text{C}$ | | | $T_a = -40$ to 85°C | | Unit | | | |
|---------------------|-----------|--------------------------|----------------------------------|----------------------------|------|-----------------------------------|------|-----------|---------------|------|---|
| | | | V_{CC} | Min. | Typ. | Max. | Min. | | Max. | | |
| Input voltage | "H" level | V_{IH} | — | 1.0 | 0.75 | — | — | 0.75 | — | V | |
| | | | | 1.5 | 1.05 | — | — | 1.05 | — | V | |
| | | | | 3.0 | 2.10 | — | — | 2.10 | — | V | |
| | "L" level | V_{IL} | — | 1.0 | — | — | 0.25 | — | 0.25 | V | |
| | | | | 1.5 | — | — | 0.45 | — | 0.45 | V | |
| | | | | 3.0 | — | — | 0.90 | — | 0.90 | V | |
| Output voltage | "H" level | V_{OH} | $V_{IN} = V_{IH}$ or V_{IL} | $I_{OH} = -20 \mu\text{A}$ | 1.0 | 0.9 | 1.0 | — | 0.9 | — | V |
| | | | | | 1.5 | 1.4 | 1.5 | — | 1.4 | — | V |
| | | | | | 3.0 | 2.9 | 3.0 | — | 2.9 | — | V |
| | | | | $I_{OH} = -1 \text{ mA}$ | 1.5 | 1.07 | 1.23 | — | 0.99 | — | V |
| | | | | | 3.0 | 2.61 | 2.68 | — | 2.55 | — | V |
| | | | | | | | | — | — | — | — |
| | "L" level | V_{OL} | $V_{IN} = V_{IL}$ | $I_{OL} = 20 \mu\text{A}$ | 1.0 | — | 0 | 0.1 | — | 0.1 | V |
| | | | | | 1.5 | — | 0 | 0.1 | — | 0.1 | V |
| | | | | | 3.0 | — | 0 | 0.1 | — | 0.1 | V |
| | | | | $I_{OL} = 1 \text{ mA}$ | 1.5 | — | 0.23 | 0.31 | — | 0.37 | V |
| | | | | | 3.0 | — | 0.23 | 0.31 | — | 0.33 | V |
| | | | | | | | | | — | — | — |
| Input current | I_{IN} | $V_{IN} = V_{CC}$ or GND | 3.6 | — | — | ± 0.1 | — | ± 1.0 | μA | | |
| Current consumption | I_{CC} | $V_{IN} = V_{CC}$ or GND | 3.6 | — | — | 1.0 | — | 10.0 | μA | | |

■ AC Electrical Characteristics

($C_L = 15$ pf, Input $t_R = t_F = 6$ ns, $V_{CC} = 3.3 \pm 0.3$ V, $T_a = 25^\circ\text{C}$ unless otherwise specified)

| Item | Symbol | Measurement Conditions | Min. | Typ. | Max. | Unit |
|-------------------------|--------------------------|------------------------|------|------|------|------|
| Output rise / fall time | t_{TLH} , t_{THL} | — | — | 4.0 | 8.0 | ns |
| Propagation delay time | t_{PLH} , t_{PHL} | — | — | 6.0 | 9.0 | ns |

($C_L = 25$ pf, Input $t_R = t_F = 6$ ns unless otherwise specified)

| Item | Symbol | Measurement Conditions | $T_a = 25^\circ\text{C}$ | | | $T_a = -40$ to 85°C | | Unit | |
|---------------------------------|--------------------------|------------------------|--------------------------|------|------|-----------------------------------|------|------|------|
| | | | V_{CC} (V) | Min. | Typ. | Max. | Min. | | Max. |
| Output rise / fall time | t_{TLH} , t_{THL} | — | 1.0 | — | 35 | 70 | — | 90 | ns |
| | | | 1.5 | — | 15 | 25 | — | 30 | ns |
| | | | 3.0 | — | 7 | 10 | — | 14 | ns |
| Propagation delay time | t_{PLH} , t_{PHL} | — | 1.0 | — | 30 | 60 | — | 75 | ns |
| | | | 1.5 | — | 15 | 25 | — | 30 | ns |
| | | | 3.0 | — | 7 | 10 | — | 14 | ns |
| Input capacitance | C_{IN} | — | — | 5 | 10 | — | 10 | pF | |
| Equivalent internal capacitance | C_{PD}^{*1} | — | — | 10 | — | — | — | pF | |

*1. C_{PD} is the no-load equivalent capacitance inside the circuitry. Refer to the measurement circuit shown below. Current consumption is averaged by the following equation.

$$I_{CC(opr)} = C_{PD} \times V_{CC} \times fin + I_{CC}$$

Measurement Circuit

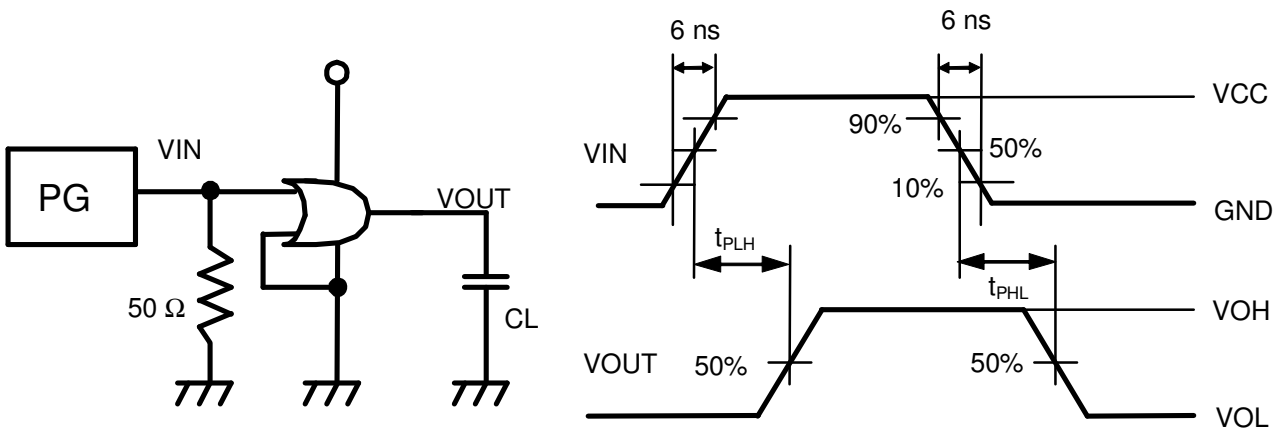

Remark No-load output during measurement of current consumption.

■ Input Pin Equivalent Circuit

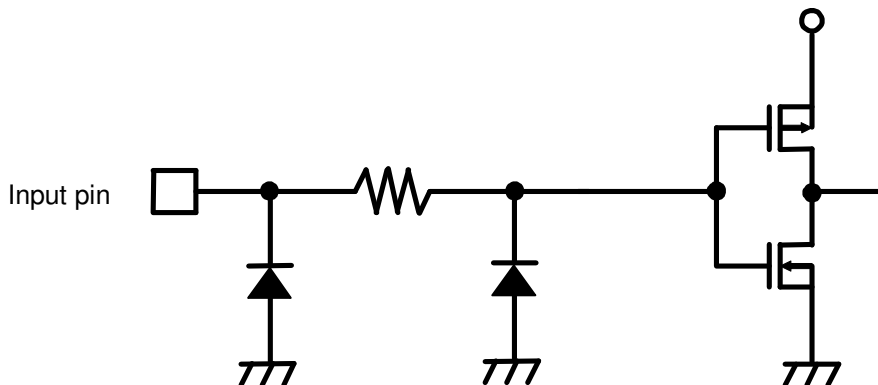

The S-75L86ANC is an EXCLUSIVE OR GATE fabricated by utilizing advanced silicon-gate CMOS technology which provides the inherent benefit of CMOS low power consumption to achieve operation by only a couple of batteries (1 to 3 V). The internal circuitry has buffered outputs to ensure high noise immunity and output stability.

Input voltage is allowed to be applied even if power voltage is not supplied because no diode is inserted between an input pin and V_{CC} .

This allows for interfaces between power supplies of different voltage, output level conversion from 3 V to 1 V and battery backup applications.

■ Features

- Wide power supply range: 1 V to 3.6 V
- Low current consumption: 1.0 μ A max. (at 3.6 V, 25°C)
- Typical propagation delay: $t_{PD} = 7$ ns (at 3 V)
- High noise immunity: $V_{NIH} = V_{NIL} = 28\% V_{CC}$ min.
- Power down protection: All pins
- Lead-free

■ Applications

- Personal computers, peripherals
- Cellular phones
- Cameras
- Games

■ Package

- SC-88A

■ Pin Configuration

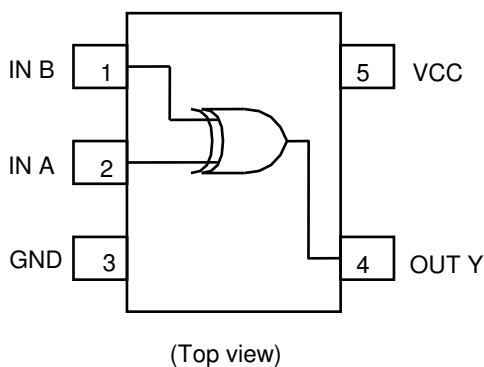

■ Marking Specification

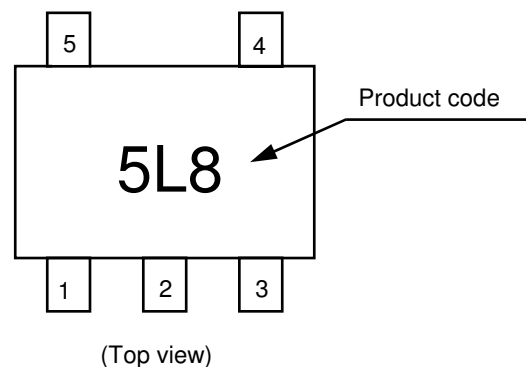

■ Logic Diagram

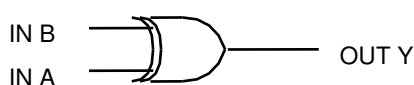

True values

| A | B | Y |
|---|---|---|
| L | L | L |
| L | H | H |
| H | L | H |
| H | H | L |

■ Product Name Structure

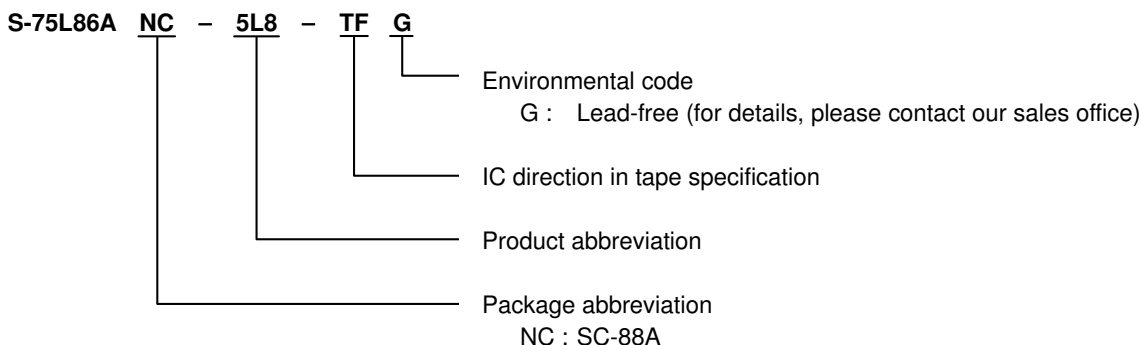

■ Absolute Maximum Ratings

(Ta = 25°C unless otherwise specified)

| Item | Symbol | Absolute Maximum Ratings | Unit |
|--------------------------------|-----------|---------------------------------|------|
| Power supply voltage | V_{CC} | -0.5 to +5.0 | V |
| Input voltage | V_{IN} | -0.5 to +5.0 | V |
| Output voltage | V_{OUT} | -0.5 to $V_{CC} + 0.5$ | V |
| Input parasitic diode current | I_{IK} | -20 | mA |
| Output parasitic diode current | I_{OK} | ±20 | mA |
| Output current | I_{OUT} | ±12.5 | mA |
| V_{CC} /GND current | I_{CC} | ±25 | mA |
| Power dissipation | P_D | 200 (When not mounted on board) | mW |
| | | 350*1 | mW |
| Operating ambient temperature | T_{opr} | -40 to +85 | °C |
| Storage temperature | T_{stg} | -65 to +150 | °C |
| Lead temperature (10 s) | T_L | 260 | °C |

*1. When mounted on board
[Mounted board]

- (1) Board size : 114.3 mm × 76.2 mm × t1.6 mm
- (2) Board name : JEDEC STANDARD51-7

Caution The absolute maximum ratings are rated values exceeding which the product could suffer physical damage. These values must therefore not be exceeded under any conditions.

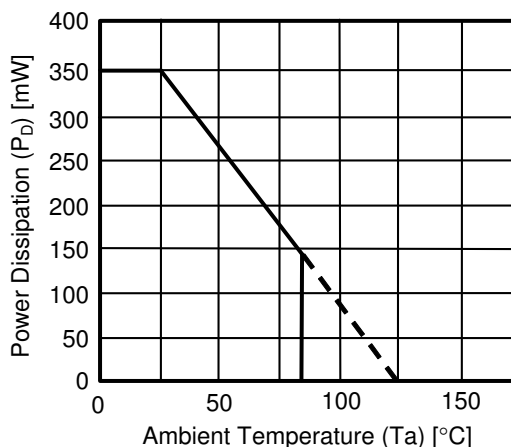

Power Dissipation of Package (When Mounted on Board)

■ Recommended Operating Conditions

| Item | Symbol | Standard | Unit |
|------------------------|------------|-------------------------------|------|
| Power voltage | V_{CC} | 1 to 3.6 | V |
| Input voltage | V_{IN} | 0 to 3.6 | V |
| Output voltage | V_{OUT} | 0 to V_{CC} | V |
| Input rise / fall time | t_R, t_F | 0 to 1000 ($V_{CC} = 1.0$ V) | ns |
| | | 0 to 500 ($V_{CC} = 2.0$ V) | ns |
| | | 0 to 400 ($V_{CC} = 3.0$ V) | ns |

■ DC Electrical Characteristics

| Item | Symbol | Conditions | $T_a = 25^\circ\text{C}$ | | | $T_a = -40$ to 85°C | | Unit | | | |
|---------------------|-----------|--------------------------|----------------------------------|----------------------------|----------------------------|-----------------------------------|------|-----------|---------------|------|------|
| | | | V_{CC} | Min. | Typ. | Max. | Min. | | Max. | | |
| Input voltage | "H" level | V_{IH} | — | 1.0 | 0.75 | — | — | 0.75 | — | V | |
| | | | | 1.5 | 1.05 | — | — | 1.05 | — | V | |
| | | | | 3.0 | 2.10 | — | — | 2.10 | — | V | |
| | "L" level | V_{IL} | — | 1.0 | — | — | 0.25 | — | 0.25 | V | |
| | | | | 1.5 | — | — | 0.45 | — | 0.45 | V | |
| | | | | 3.0 | — | — | 0.90 | — | 0.90 | V | |
| Output voltage | "H" level | V_{OH} | $V_{IN} = V_{IH}$ or V_{IL} | $I_{OH} = -20 \mu\text{A}$ | 1.0 | 0.9 | 1.0 | — | 0.9 | — | V |
| | | | | | 1.5 | 1.4 | 1.5 | — | 1.4 | — | V |
| | | | | | 3.0 | 2.9 | 3.0 | — | 2.9 | — | V |
| | | | | $I_{OH} = -1 \text{ mA}$ | 1.5 | 1.07 | 1.23 | — | 0.99 | — | V |
| | | | | | 3.0 | 2.61 | 2.68 | — | 2.55 | — | V |
| | | | | | $I_{OH} = -2.6 \text{ mA}$ | 3.0 | 2.61 | 2.68 | — | 2.55 | — |
| | "L" level | V_{OL} | $V_{IN} = V_{IH}$ or V_{IL} | $I_{OL} = 20 \mu\text{A}$ | 1.0 | — | 0 | 0.1 | — | 0.1 | V |
| | | | | | 1.5 | — | 0 | 0.1 | — | 0.1 | V |
| | | | | | 3.0 | — | 0 | 0.1 | — | 0.1 | V |
| | | | | $I_{OL} = 1 \text{ mA}$ | 1.5 | — | 0.23 | 0.31 | — | 0.37 | V |
| | | | | | 3.0 | — | 0.23 | 0.31 | — | 0.33 | V |
| | | | | | $I_{OL} = 2.6 \text{ mA}$ | 3.0 | — | 0.23 | 0.31 | — | 0.33 |
| Input current | I_{IN} | $V_{IN} = V_{CC}$ or GND | 3.6 | — | — | ± 0.1 | — | ± 1.0 | μA | | |
| Current consumption | I_{CC} | $V_{IN} = V_{CC}$ or GND | 3.6 | — | — | 1.0 | — | 10.0 | μA | | |

■ AC Electrical Characteristics

($C_L = 15$ pf, Input $t_R = t_F = 6$ ns, $V_{CC} = 3.3 \pm 0.3$ V, $T_a = 25^\circ\text{C}$ unless otherwise specified)

| Item | Symbol | Measurement Conditions | Min. | Typ. | Max. | Unit |
|-------------------------|--------------------------|------------------------|------|------|------|------|
| Output rise / fall time | t_{TLH} , t_{THL} | — | — | 4.0 | 8.0 | ns |
| Propagation delay time | t_{PLH} , t_{PHL} | — | — | 6.0 | 9.0 | ns |

($C_L = 25$ pf, Input $t_R = t_F = 6$ ns unless otherwise specified)

| Item | Symbol | Measurement Conditions | $T_a = 25^\circ\text{C}$ | | | $T_a = -40$ to 85°C | | Unit | |
|---------------------------------|--------------------------|------------------------|--------------------------|------|------|-----------------------------------|------|------|------|
| | | | V_{CC} (V) | Min. | Typ. | Max. | Min. | | Max. |
| Output rise / fall time | t_{TLH} , t_{THL} | — | 1.0 | — | 35 | 70 | — | 90 | ns |
| | | | 1.5 | — | 15 | 25 | — | 30 | ns |
| | | | 3.0 | — | 7 | 10 | — | 14 | ns |
| Propagation delay time | t_{PLH} , t_{PHL} | — | 1.0 | — | 30 | 60 | — | 75 | ns |
| | | | 1.5 | — | 15 | 25 | — | 30 | ns |
| | | | 3.0 | — | 7 | 10 | — | 14 | ns |
| Input capacitance | C_{IN} | — | — | 5 | 10 | — | 10 | pF | |
| Equivalent internal capacitance | C_{PD}^{*1} | — | — | 10 | — | — | — | pF | |

*1. C_{PD} is the no-load equivalent capacitance inside the circuitry. Refer to the measurement circuit shown below.
 Current consumption is averaged by the following equation.

$$I_{CC(opr)} = C_{PD} \times V_{CC} \times fin + I_{CC}$$

Measurement Circuit

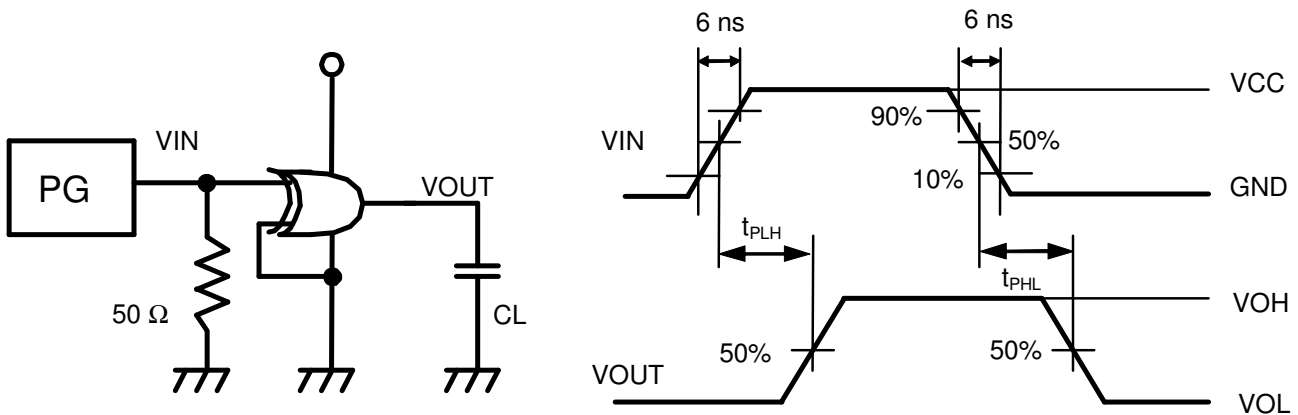

Remark No-load output during measurement of current consumption.

■ Input Pin Equivalent Circuit

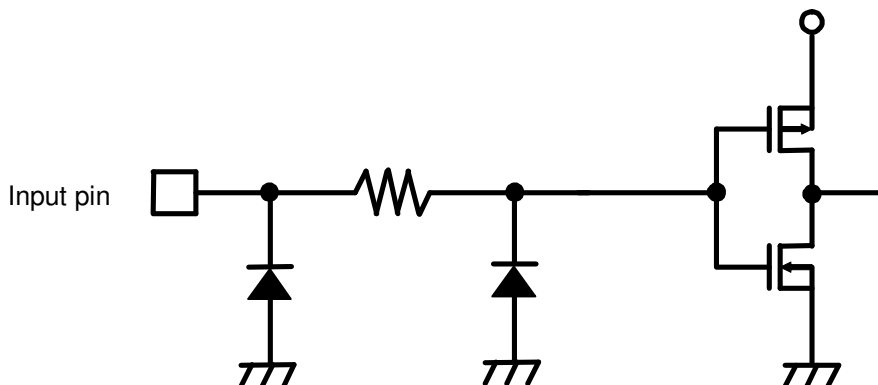

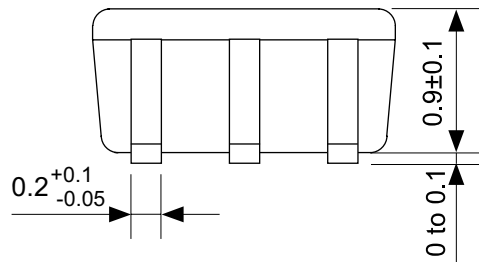
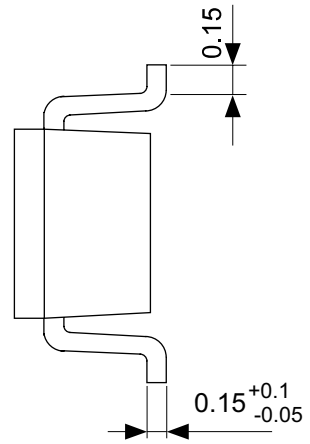
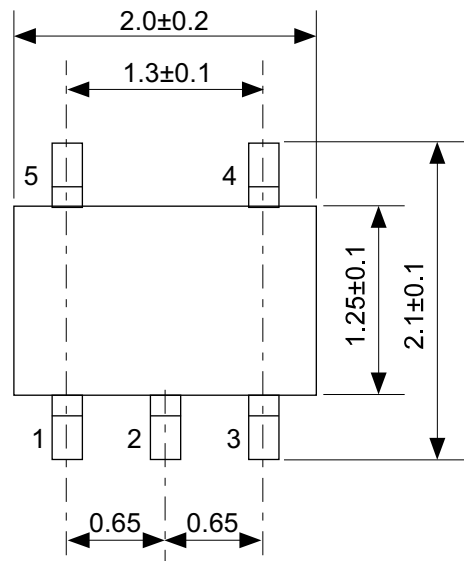

No. NP005-B-P-SD-1.1

| | |
|------------------------|------------------------|
| TITLE | SC88A-B-PKG Dimensions |
| No. | NP005-B-P-SD-1.1 |
| SCALE | |
| UNIT | mm |
| Seiko Instruments Inc. | |

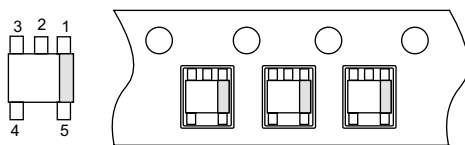
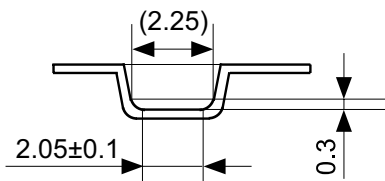
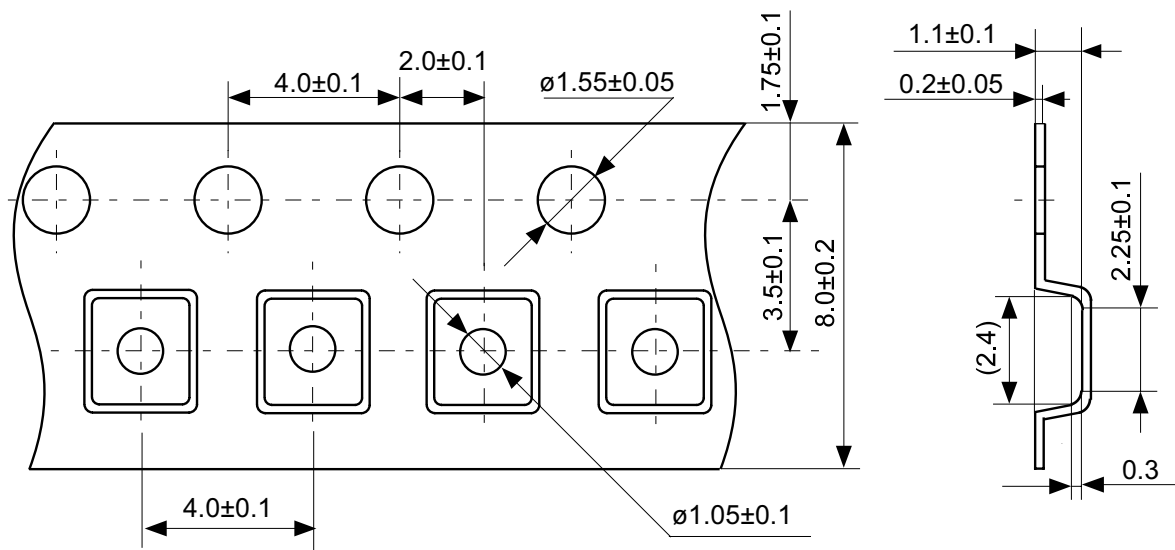

→
Feed direction

No. NP005-B-C-SD-2.0

| | |
|------------------------|----------------------|
| TITLE | SC88A-B-Carrier Tape |
| No. | NP005-B-C-SD-2.0 |
| SCALE | |
| UNIT | mm |
| Seiko Instruments Inc. | |

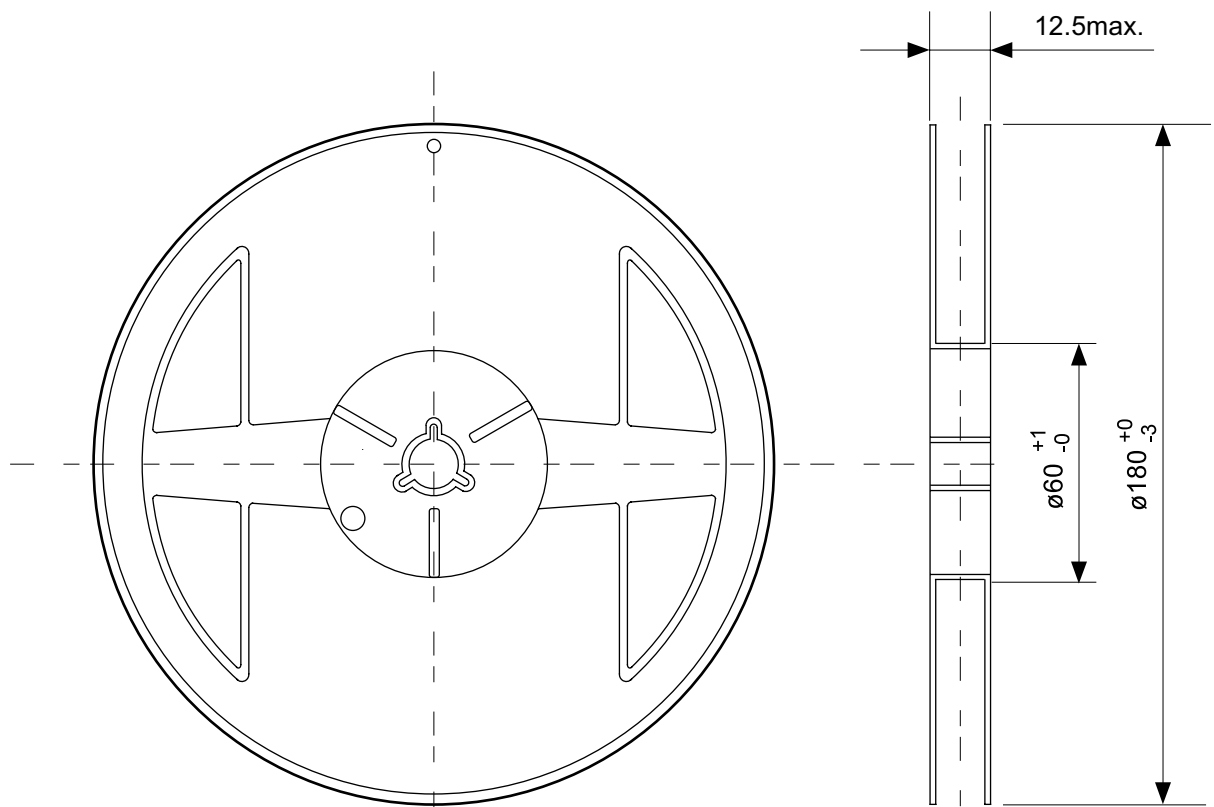

Enlarged drawing in the central part

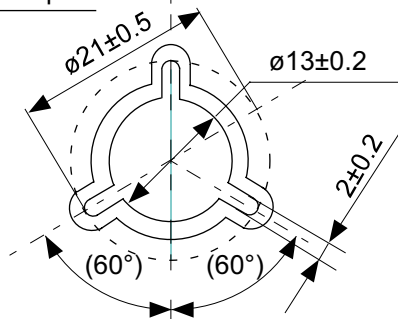

No. NP005-B-R-SD-2.1

| | | | |
|------------------------|------------------|------|------|
| TITLE | SC88A-B-Reel | | |
| No. | NP005-B-R-SD-2.1 | | |
| SCALE | | QTY. | 3000 |
| UNIT | mm | | |
| | | | |
| Seiko Instruments Inc. | | | |



Seiko Instruments Inc.
www.sii-ic.com

- The information described herein is subject to change without notice.
- Seiko Instruments Inc. is not responsible for any problems caused by circuits or diagrams described herein whose related industrial properties, patents, or other rights belong to third parties. The application circuit examples explain typical applications of the products, and do not guarantee the success of any specific mass-production design.
- When the products described herein are regulated products subject to the Wassenaar Arrangement or other agreements, they may not be exported without authorization from the appropriate governmental authority.
- Use of the information described herein for other purposes and/or reproduction or copying without the express permission of Seiko Instruments Inc. is strictly prohibited.
- The products described herein cannot be used as part of any device or equipment affecting the human body, such as exercise equipment, medical equipment, security systems, gas equipment, or any apparatus installed in airplanes and other vehicles, without prior written permission of Seiko Instruments Inc.
- The products described herein are not designed to be radiation-proof.
- Although Seiko Instruments Inc. exerts the greatest possible effort to ensure high quality and reliability, the failure or malfunction of semiconductor products may occur. The user of these products should therefore give thorough consideration to safety design, including redundancy, fire-prevention measures, and malfunction prevention, to prevent any accidents, fires, or community damage that may ensue.