

***Bidirectional voltage level translator for open-drain and  
push-pull applications*****UM2002S8 SOP8****UM2002M8 MSOP8****General Description**

The UM2002 is a bidirectional voltage level translator operational from 1.0V to 3.6V ( $V_{ref(A)}$ ) and 1.8V to 5.5V ( $V_{ref(B)}$ ), which allows bidirectional voltage translations between 1.0V and 5V without the need for a direction pin in open-drain or push-pull applications. Bit widths ranging from 1-bit or 2-bit are offered for level translation application with transmission speeds < 33 MHz for an open-drain system with a 50 pF capacitance and a pull-up of 197 $\Omega$ .

The translators provide excellent ESD protection to lower voltage devices, and at the same time protect less ESD-resistant devices.

**Applications**

- SPI, MICROWIRE, and I<sup>2</sup>C Level Translation
- Low-Voltage ASIC Level Translation
- Smart Card Readers
- Cell-phone Cradles
- Portable POS Systems
- Portable Communication Devices
- Low-Cost Serial Interfaces
- Cell-Phones
- GPS
- Telecommunications Equipment
- Consumer Electronics
- Household Appliances

**Features**

- Provides bidirectional voltage translation with no direction pin
- Less than 1.5 ns maximum propagation delay
- Allows voltage level translation between:
  - 1). 1.0V  $V_{ref(A)}$  and 1.8V, 2.5V, 3.3V or 5V  $V_{ref(B)}$
  - 2). 1.2V  $V_{ref(A)}$  and 1.8V, 2.5V, 3.3V or 5V  $V_{ref(B)}$
  - 3). 1.8V  $V_{ref(A)}$  and 3.3V or 5V  $V_{ref(B)}$
  - 4). 2. V  $V_{ref(A)}$  and 5V  $V_{ref(B)}$
  - 5). 3.3V  $V_{ref(A)}$  and 5V  $V_{ref(B)}$
- Low 3.5 $\Omega$  ON-state connection between input and output ports provides less signal distortion
- 5V tolerant I/O ports to support mixed-mode signal operation
- High-impedance An and Bn pins for EN = LOW
- Lock-up free operation
- Flow through pinout for ease of printed-circuit board trace routing
- ESD protection exceeds:
  - 4kV HBM per JESD22-A114
  - 200V MM per JESD22-A115
  - 1000V CDM per JESD22-C101
- Packages offered: SOP, MSOP

## Pin Configurations

## Top View

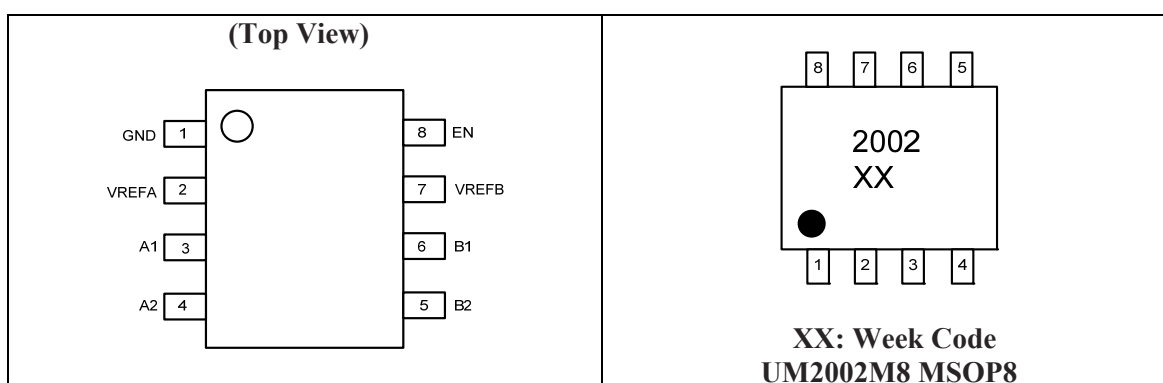
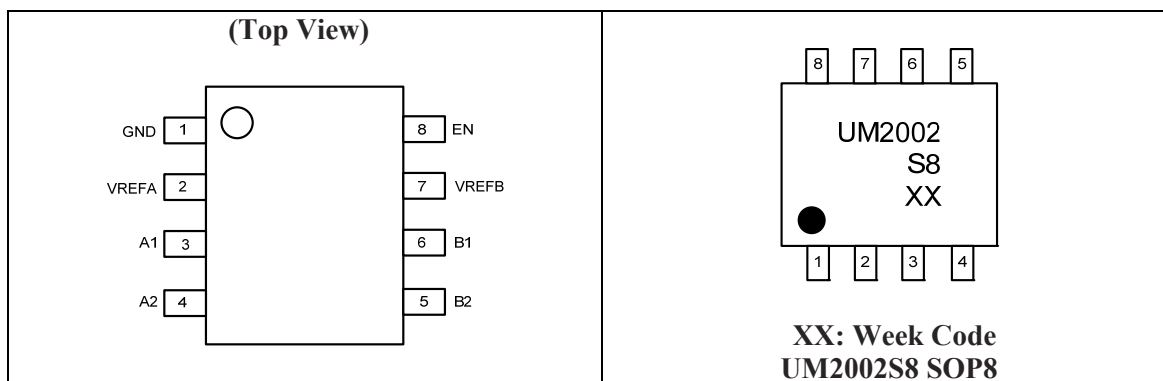

## Pin Description

Pin Number	Symbol	Function
1	GND	Ground (0V)
2	VREFA	Low-voltage side reference supply voltage for An
3,4	A1,A2	Low-voltage side; connected to VREFA through a pull-up resistor
5,6	B1,B2	High-voltage side; connected to VREFB through a pull-up resistor
7	VREFB	High-voltage side reference supply voltage for Bn
8	EN	Switch enable input; connected to VREFB and pulled-up through a high resistor

## Ordering Information

Part Number	Packaging Type	Marking Code	Shipping Qty
UM2002S8	SOP8	UM2002S8	2500pcs/13Inch Tape & Reel
UM2002M8	MSOP8	2002	3000pcs/13Inch Tape & Reel

**Absolute Maximum Ratings (Note 1)**

Over operating free-air temperature range (unless otherwise noted)

Symbol	Parameter	Value	Unit
$V_{ref(A)}$	Reference Voltage (A)	-0.5 to +6	V
$V_{ref(B)}$	Reference Voltage (B)	-0.5 to +6	V
$V_I$	Input Voltage	-0.5(Note 2) to +6	V
$V_{I/O}$	Voltage on an input/output pin	-0.5(Note 2) to +6	V
$I_{ch}$	Channel Current (DC)	+128	mA
$I_{IK}$	Input Clamp Current	$V_I < 0V$	-50 mA
$T_{stg}$	Storage Temperature	-65 to +150	°C

Note 1: Stresses beyond those listed under "absolute maximum ratings" may cause permanent damage to the device. These are stress ratings only, and functional operation of the device at these or any other conditions beyond those indicated under "recommended operating conditions" is not implied. Exposure to absolute-maximum-rated conditions for extended periods may affect device reliability.

Note 2: The input and input/output negative voltage ratings may be exceeded if the input and input/output clamp current ratings are observed.

**Recommended Operating Conditions**

Symbol	Parameter	Conditions	Min	Max	Unit
$V_{I/O}$	Voltage on an input/output pin	An, Bn	0	5.5	V
$V_{ref(A)}$ (Note 3)	Reference Voltage (A)	VREFA	0	5.4	V
$V_{ref(B)}$ (Note 3)	Reference Voltage (B)	VREFB	0	5.5	V
$V_{I(EN)}$	Input Voltage on pin EN		0	5.5	V
$I_{sw(pass)}$	Pass Switch Current			64	mA
$T_{amb}$	Ambient Temperature	Operating in free-air	-40	+85	°C

Note 3:  $V_{ref(A)} \leq V_{ref(B)} - 1$  V for best results in level shifting applications.

**Electrical Characteristics**
 $T_{amb} = -40\text{ }^{\circ}\text{C}$  to  $+85\text{ }^{\circ}\text{C}$ , unless otherwise specified.

Symbol	Parameter	Conditions	Min	Typ (Note 4)	Max	Unit
$V_{IK}$	Input Clamping Voltage	$I_I = -18\text{mA}$ ; $V_{I(EN)} = 0\text{V}$			-1.2	V
$I_{IH}$	HIGH-level Input Current	$V_I = 5\text{V}$ ; $V_{I(EN)} = 0\text{V}$			5	$\mu\text{A}$
$C_{i(EN)}$	Input Capacitance on pin EN	$V_I = 0\text{V}$ or $3\text{V}$		12		pF
$C_{io(off)}$	Off-state input/output capacitance	An, Bn; $V_O = 0\text{V}$ or $3\text{V}$ ; $V_{I(EN)} = 0\text{V}$		10	12	pF
$C_{io(on)}$	On-state input/output capacitance	An, Bn; $V_O = 0\text{V}$ or $3\text{V}$ ; $V_{I(EN)} = 3\text{V}$		8	12.5 (Note 5)	pF
$R_{on}$	ON-state resistance (Note 6)	An, Bn; $V_I = 0\text{V}$ ; $I_O = 64\text{mA}$ ; $V_{I(EN)} = 4.5\text{V}$ (Note 7)	1	2.5	5.0	$\Omega$
		An, Bn; $V_I = 2.4\text{V}$ ; $I_O = 15\text{mA}$ ; $V_{I(EN)} = 4.5\text{V}$		4.5	7.5	

Note 4: All typical values are at  $T_{amb} = 25^{\circ}\text{C}$ .

Note 5: Not production tested, maximum value based on characterization data of typical parts.

Note 6: Measured by the voltage drop between the An and Bn terminals at the indicated current through the switch. ON-state resistance is determined by the lowest voltage of the two terminals.

Note 7: Guaranteed by design.

**Switching Characteristics (translating down)**

Over recommended operating free-air temperature range(unless otherwise noted). Values guaranteed by design.

Symbol	Parameter	Test Conditions	C <sub>L</sub> =50pF		C <sub>L</sub> =30pF		C <sub>L</sub> =15pF		Unit
			Min	Max	Min	Max	Min	Max	
V <sub>I(EN)</sub> = 3.3V; V <sub>IH</sub> = 3.3V; V <sub>IL</sub> = 0V; V <sub>M</sub> = 1.15V(see Figure 1).									
t <sub>PLH</sub>	LOW to HIGH propagation delay	from (input) Bn to (output) An.	0	3.5	0	2.7	0	2.2	ns
t <sub>PHL</sub>	HIGH to LOW propagation delay		0	3.5	0	3.0	0	2.3	ns
V <sub>I(EN)</sub> = 2.5V; V <sub>IH</sub> = 2.5V; V <sub>IL</sub> = 0V; V <sub>M</sub> = 0.75V (see Figure 1).									
t <sub>PLH</sub>	LOW to HIGH propagation delay	from (input) Bn to (output) An.	0	3.5	0	2.7	0	2.2	ns
t <sub>PHL</sub>	HIGH to LOW propagation delay		0	4.0	0	3.0	0	2.3	ns

**Switching Characteristics (translating up)**

Over recommended operating free-air temperature range(unless otherwise noted). Values guaranteed by design.

Symbol	Parameter	Test Conditions	C <sub>L</sub> =50pF		C <sub>L</sub> =30pF		C <sub>L</sub> =15pF		Unit
			Min	Max	Min	Max	Min	Max	
V <sub>I(EN)</sub> = 3.3V; V <sub>IH</sub> = 2.3V; V <sub>IL</sub> = 0V; V <sub>TT</sub> = 3.3V; V <sub>M</sub> = 1.15V; R <sub>L</sub> = 300Ω(see Figure 1).									
t <sub>PLH</sub>	LOW to HIGH propagation delay	from (input) An to (output) Bn.	0	3.35	0	2.5	0	2.0	ns
t <sub>PHL</sub>	HIGH to LOW propagation delay		0	4.35	0	3.25	0	2.4	ns
V <sub>I(EN)</sub> = 2.5V; V <sub>IH</sub> = 1.5V; V <sub>IL</sub> = 0V; V <sub>TT</sub> = 2.5V; V <sub>M</sub> = 0.75V; R <sub>L</sub> = 300Ω (see Figure 1).									
t <sub>PLH</sub>	LOW to HIGH propagation delay	from (input) An to (output) Bn.	0	3.35	0	2.5	0	2.0	ns
t <sub>PHL</sub>	HIGH to LOW propagation delay		0	4.5	0	3.5	0	2.5	ns

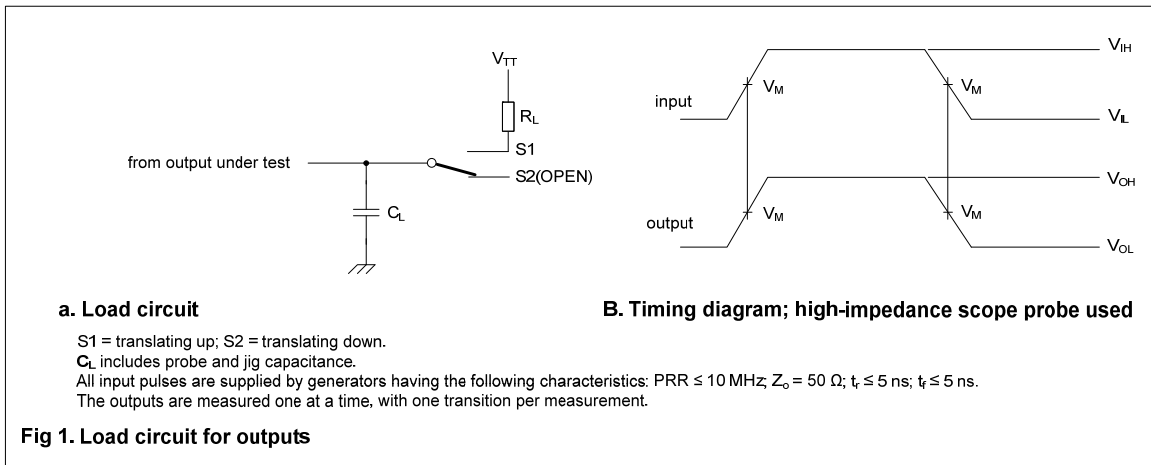

## Applications Information

### Detail Description

The UM2002 is a bidirectional voltage level translator operational from 1.0V to 3.6V ( $V_{ref(A)}$ ) and 1.8V to 5.5V ( $V_{ref(B)}$ ), which allows bidirectional voltage translations between 1.0V and 5V without the need for a direction pin in open-drain or push-pull applications.

When the An or Bn port is LOW, the clamp is in the ON-state and a low resistance connection exists between the An and Bn ports. The low ON-state resistance ( $R_{on}$ ) of the switch allows connections to be made with minimal propagation delay. Assuming the higher voltage is on the Bn port when the Bn port is HIGH, the voltage on the An port is limited to the voltage set by  $V_{ref(A)}$ . When the An port is HIGH, the Bn port is pulled to the drain pull-up supply voltage ( $V_{pu(D)}$ ) by the pull-up resistors. This functionality allows a seamless translation between higher and lower voltages selected by the user without the need for directional control.

When EN is HIGH, the translator switch is on, and the An I/O are connected to the Bn I/O, respectively, allowing bidirectional data flow between ports. When EN is LOW, the translator switch is off, and a high-impedance state exists between ports. The EN input circuit is designed to be supplied by  $V_{ref(B)}$ . To ensure the high-impedance state during power-up or power-down, EN must be LOW.

All channels have the same electrical characteristics and there is minimal deviation from one output to another in voltage or propagation delay. This is a benefit over discrete transistor voltage translation solutions, since the fabrication of the switch is symmetrical.

## Enable and Disable

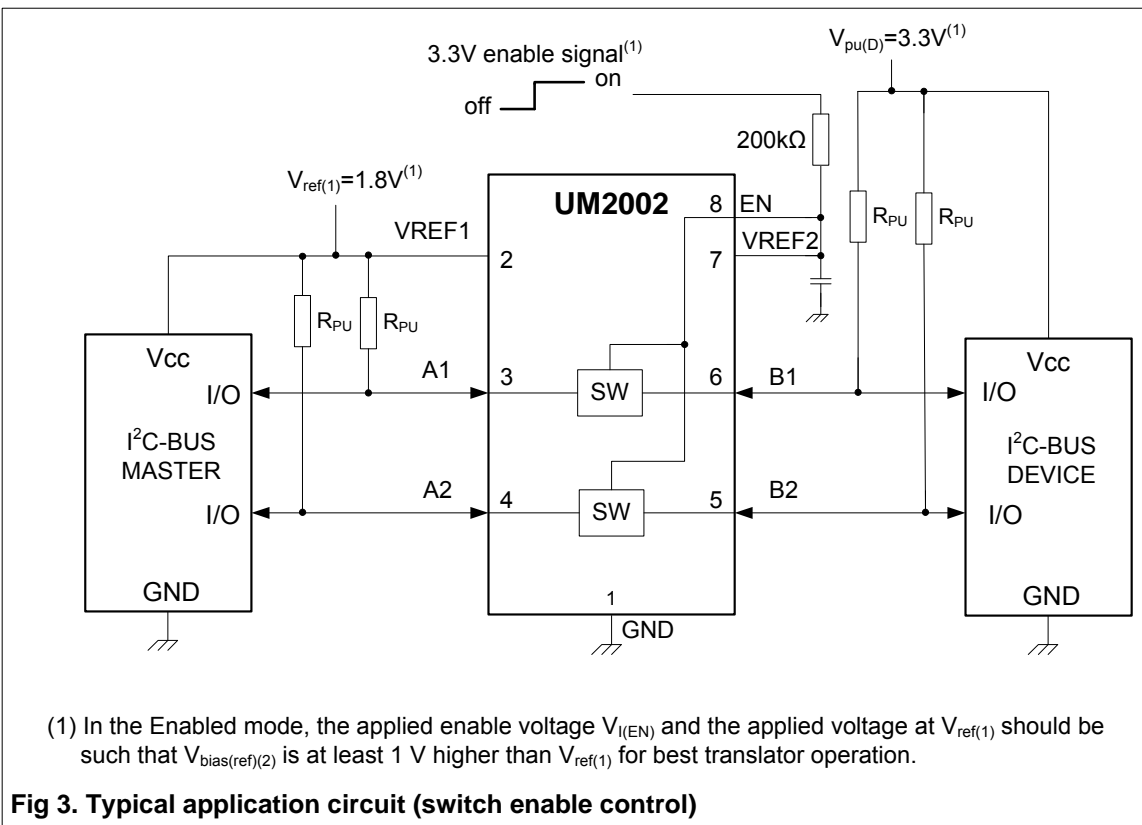
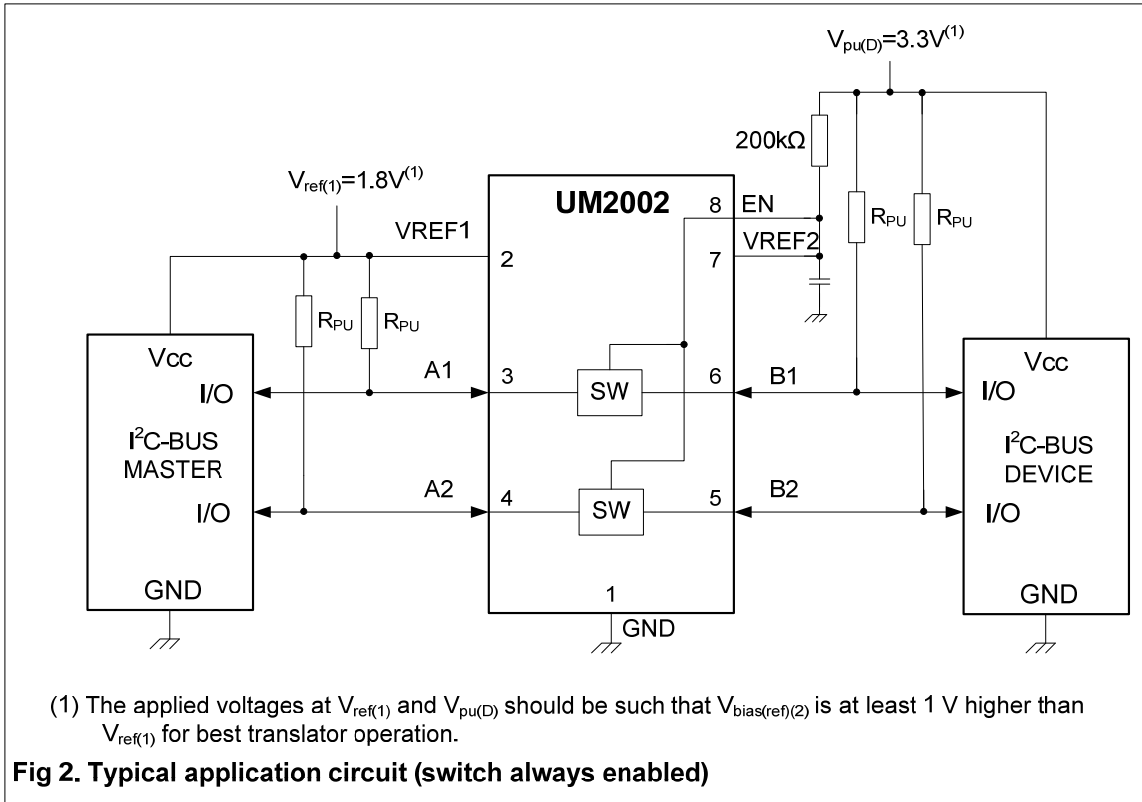

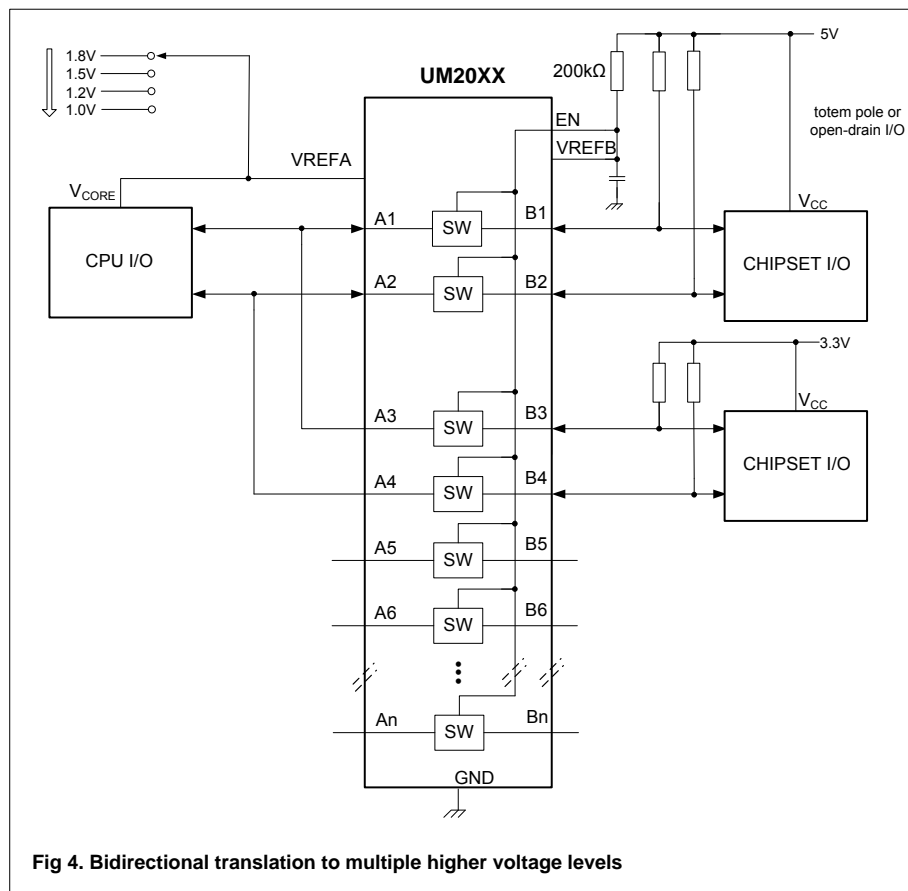

Fig 4. Bidirectional translation to multiple higher voltage levels

## Bidirectional translation

For the bidirectional clamping configuration (higher voltage to lower voltage or lower voltage to higher voltage), the EN input must be connected to VREFB and both pins pulled to HIGH side  $V_{pu(D)}$  through a pull-up resistor (typically 200kΩ). This allows VREFB to regulate the EN input. A filter capacitor on VREFB is recommended. The master output driver can be totem pole or open-drain (pull-up resistors may be required) and the slave device output can be totem pole or open-drain (pull-up resistors are required to pull the Bn outputs to  $V_{pu(D)}$ ). However, if either output is totem pole, data must be unidirectional or the outputs must be 3-stateable and be controlled by some direction-control mechanism to prevent HIGH-to-LOW contentions in either direction. If both outputs are open-drain, no direction control is needed.

The reference supply voltage ( $V_{ref(A)}$ ) is connected to the processor core power supply voltage. When VREFB is connected through a 200kΩ resistor to a 3.3V to 5.5V  $V_{pu(D)}$  power supply, and  $V_{ref(A)}$  is set between 1.0V and ( $V_{pu(D)} - 1V$ ), the output of each An has a maximum output voltage equal to VREFA, and the output of each Bn has a maximum output voltage equal to  $V_{pu(D)}$ .

**Application operating conditions**

Refer to Figure 4

Symbol	Parameter	Conditions	Min	Typ (Note 8)	Max	Unit
$V_{\text{ref(B)}}$	Reference Bias Voltage (B)		$V_{\text{ref(A)}} + 0.6$	2.1	5	V
$V_{\text{I(EN)}}$	Input Voltage on pin EN		$V_{\text{ref(A)}} + 0.6$	2.1	5	V
$V_{\text{ref(A)}}$	Reference Voltage (A)		0	1.5	4.4	V
$I_{\text{sw(pass)}}$	Pass Switch Current			14		mA
$I_{\text{ref}}$	Reference Current	Transistor		5		$\mu\text{A}$
$T_{\text{amb}}$	Ambient Temperature	Operating in free-air	-40		+85	$^{\circ}\text{C}$

 Note 8: All typical values are at  $T_{\text{amb}} = 25^{\circ}\text{C}$ .

**Sizing pull-up resistor**

The pull-up resistor value needs to limit the current through the pass transistor when it is in the ON state to about 15mA. This ensures a pass voltage of 260mV to 350mV. If the current through the pass transistor is higher than 15mA, the pass voltage also is higher in the ON state. To set the current through each pass transistor at 15mA, the pull-up resistor value is calculated as:

$$R_{\text{PU}} = \frac{V_{\text{pu(D)}} - 0.35\text{V}}{0.015\text{A}}$$

The table below summarizes resistor reference voltages and currents at 15mA, 10mA, and 3mA. The resistor values shown in the +10 % column or a larger value should be used to ensure that the pass voltage of the transistor would be 350 mV or less. The external driver must be able to sink the total current from the resistors on both sides of the UM2002 device at 0.175V, although the 15mA only applies to current flowing through the UM2002 device.

**Pull-up resistor values**

 Calculated for  $V_{\text{OL}} = 0.35\text{V}$ ; assumes output driver  $V_{\text{OL}} = 0.175\text{V}$  at stated current.

$V_{\text{pu(D)}}$	Pull-up resistor value ( $\Omega$ )					
	15mA		10mA		3mA	
	Nominal	+10 % (Note 9)	Nominal	+10 % (Note 9)	Nominal	+10 % (Note 9)
5V	310	341	465	512	1550	1705
3.3V	197	217	295	325	983	1082
2.5V	143	158	215	237	717	788
1.8V	97	106	145	160	483	532
1.5V	77	85	115	127	383	422
1.2V	57	63	85	94	283	312

 Note 9: +10 % to compensate for  $V_{\text{CC}}$  range and resistor tolerance.

## Package Information

### UM2002S8 SOP8

#### Outline Drawing

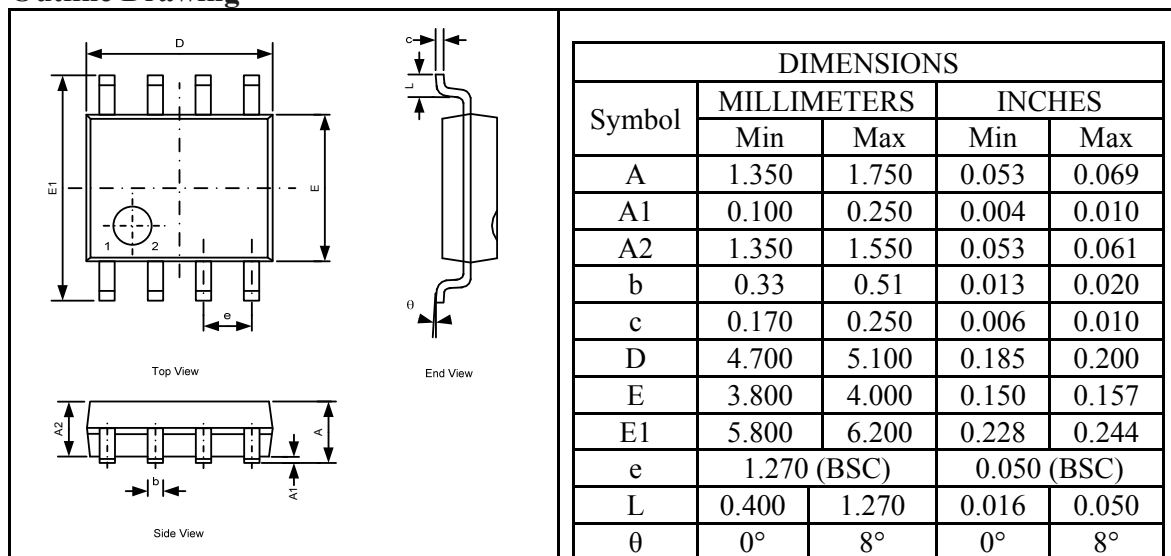

#### Land Pattern

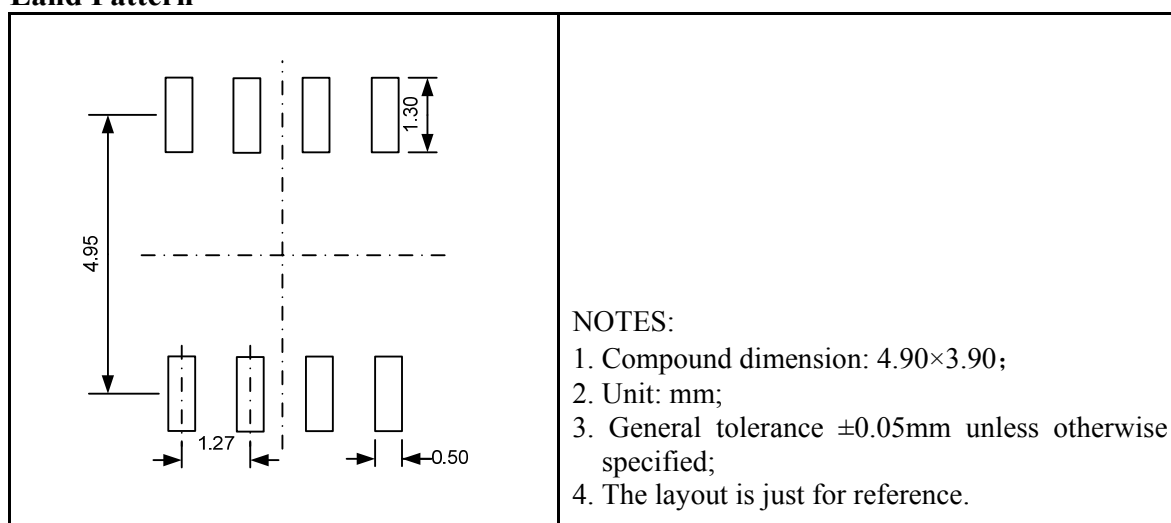

#### Tape and Reel Orientation

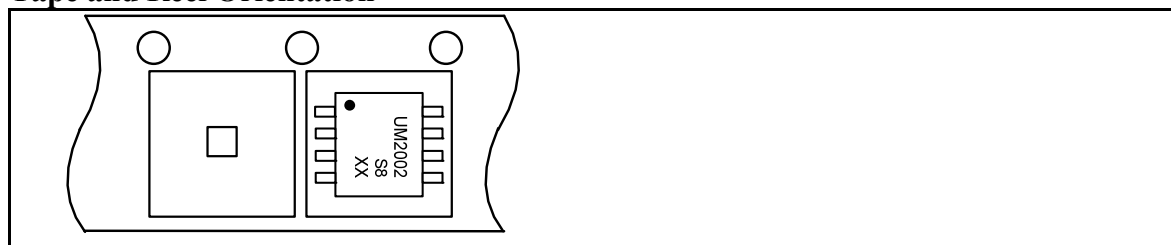

## UM2002M8: MSOP8

### Outline Drawing

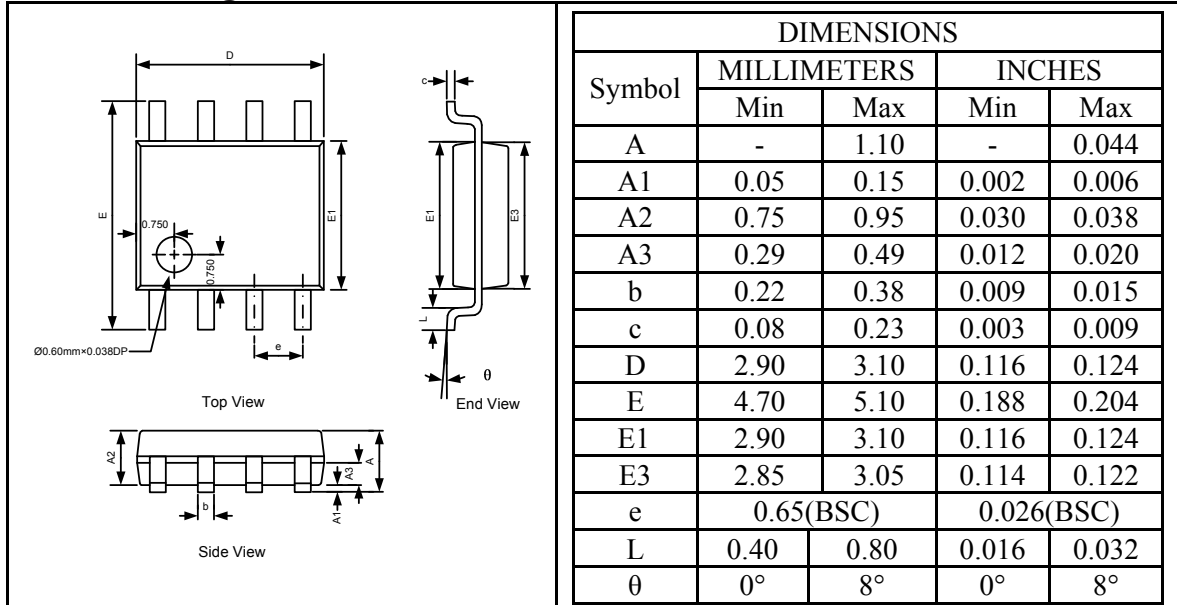

### Land Pattern

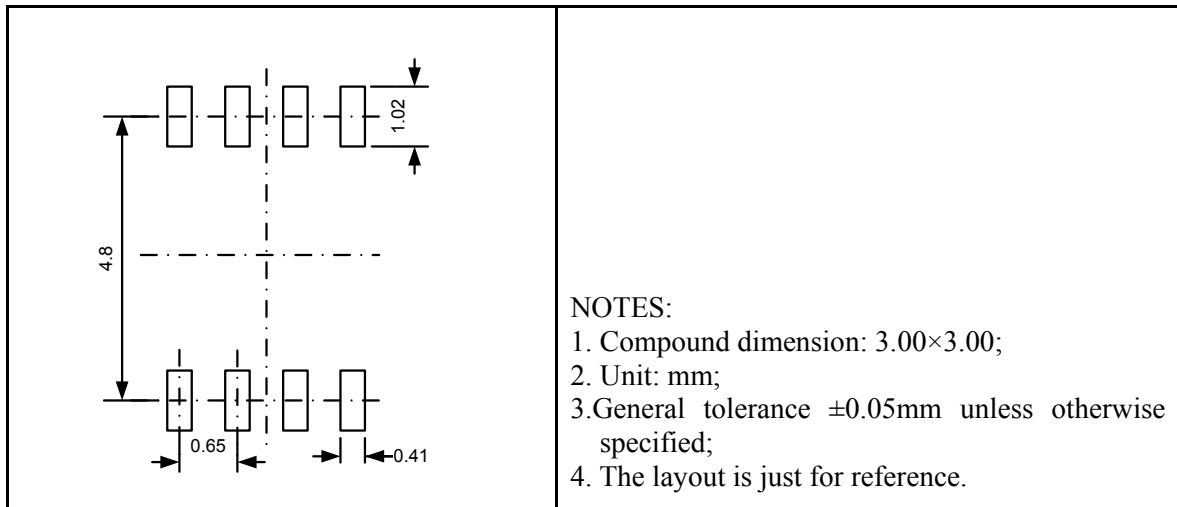

### Tape and Reel Orientation

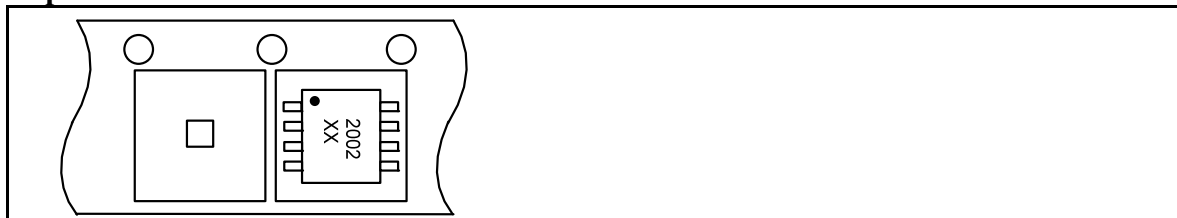

---

**IMPORTANT NOTICE**

The information in this document has been carefully reviewed and is believed to be accurate. Nonetheless, this document is subject to change without notice. Union assumes no responsibility for any inaccuracies that may be contained in this document, and makes no commitment to update or to keep current the contained information, or to notify a person or organization of any update. Union reserves the right to make changes, at any time, in order to improve reliability, function or design and to attempt to supply the best product possible.



Union Semiconductor, Inc

Add: 2F, No. 3, Lane 647 Songtao Road, Shanghai 201203

Tel: 021-51093966

Fax: 021-51026018

Website: [www.union-ic.com](http://www.union-ic.com)