

***Fail-Safe, Single Supply RS-232 Transceivers******UM3232ESE SOP16******UM3232EPE DIP16******UM3232EUE TSSOP16*****General Description**

The UM3232ExE series are low power single supply RS232 interface transceivers consist of two line drivers, two line receivers, and dual charge pump circuit. The device meets the requirements of TIA/EIA-232 standard and provides the electrical interface between an asynchronous communication controller and the serial-port connector. The on chip charge pump and four small external capacitors act as onboard DC to DC converter, allow chip operated from single +3.0V to +5.5V supply. The device operates at data signaling rates over 250Kbps while maintaining RS-232 output levels. UM3232ExE comes in 16 pin DIP, SOP and TSSOP packages, operating over industrial temperature ranges.

**Applications**

- Notebook and Palmtop Computers
- Battery-Powered Equipment
- Hand-Held Equipment
- POS terminal

**Features**

- Meets true EIA/TIA-232-F Standards from a +3.0V to +5.5V power supply
- 250 Kbps Minimum Transmission Rate
- Guaranteed 30V/ $\mu$ s Max Slew Rate
- Latch-Up Performance Exceeds 200mA

**Ordering Information**

<b>Part Number</b>	<b>Temp. Range</b>	<b>Package Type</b>
UM3232ESE	-40°C to +85°C	SOP16
UM3232EPE	-40°C to +85°C	DIP16
UM3232EUE	-40°C to +85°C	TSSOP16

**Absolute Maximum Ratings (Note 1)**

Symbol	Parameter	Value	Unit
V <sub>CC</sub>	Supply Voltage on V <sub>CC</sub>	-0.3 to +6	V
V <sub>+</sub>	Voltage on V <sub>+</sub>	(V <sub>CC</sub> - 0.3) to +14	V
V <sub>-</sub>	Voltage on V <sub>-</sub>	-14 to +0.3	V
T <sub>IN</sub>	Voltage on T <sub>IN</sub>	-0.3 to (V <sub>CC</sub> + 0.3)	V
R <sub>IN</sub>	Voltage on R <sub>IN</sub>	±30	V
T <sub>OUT</sub>	Voltage on T <sub>OUT</sub>	(V <sub>-</sub> - 0.3) to (V <sub>+</sub> + 0.3)	V
R <sub>OUT</sub>	Voltage on R <sub>OUT</sub>	-0.3 to (V <sub>CC</sub> + 0.3)	V
	Short-Circuit Duration, T <sub>OUT</sub>	Continuous	
P <sub>D</sub>	Continuous Power Dissipation at T <sub>A</sub> = 70°C	SOP16	696
		DIP16	842
		TSSOP16	754.7
T <sub>A</sub>	Operating Temperature Range	-40 to +85	°C
T <sub>STG</sub>	Storage Temperature Range	-65 to +165	°C
T <sub>L</sub>	Maximum Lead Temperature for Soldering 10 seconds	+300	°C

Note 1: Stresses beyond those listed under “Absolute Maximum Ratings” may cause permanent damage to the device. These are stress ratings only, and functional operation of the device at these or any other conditions beyond those indicated in the operational sections of the specifications is not implied. Exposure to absolute maximum rating conditions for extended periods may affect device reliability.

**Electrical Characteristics**

( $V_{CC}=+3.0V$  to  $+5.5V$ ,  $C1-C4=0.1\mu F$ ,  $T_A=T_{MIN}$  to  $T_{MAX}$ , unless otherwise noted. Typical values are at  $T_A=25^\circ C$ )

Parameter	Symbol	Conditions	Min	Typ	Max	Unit	
<b>DC CHARACTERISTICS</b>							
$V_{CC}$ Supply Current	$I_{CC}$	No load, $T_A = +25^\circ C$		3	5	mA	
<b>LOGIC</b>							
Input Leakage Current		$T_{IN} = 0V$ to $V_{CC}$			$\pm 1$	$\mu A$	
Input Threshold Low	$V_{IL}$	$T_{IN}$			0.8	V	
Input Threshold High	$V_{IH}$	$V_{CC} = 3.3V$ , $T_{IN}$	2.0			V	
		$V_{CC} = 5.0V$ , $T_{IN}$	3.0				
Output Voltage Low	$V_{OL}$	$R_{OUT}$ ; $I_{OUT} = 3.2mA$			0.4	V	
Output Voltage High	$V_{OH}$	$R_{OUT}$ ; $I_{OUT} = -1.0mA$	$V_{CC}-0.6$	$V_{CC}-0.1$		V	
<b>EIA/TIA-232E RECEIVER INPUTS</b>							
Input Voltage Range			-30		30	V	
Input Threshold Low		$T_A = +25^\circ C$ , $V_{CC} = 3.3V$	Normal operation	0.6	1.1	V	
Input Threshold High		$T_A = +25^\circ C$ , $V_{CC} = 3.3V$	Normal operation		1.5	2.4	V
Input Hysteresis		$V_{CC} = 3.3V$	0.1		0.2	V	
Input Resistance		$T_A = +25^\circ C$ , $V_{CC} = 3.3V$	3	5	7	k $\Omega$	
<b>EIA/TIA-232E TRANSMITTER OUTPUTS</b>							
Output Voltage Swing		All drivers loaded with 3k $\Omega$ to ground	$\pm 5$	$\pm 5.4$		V	
Output Resistance		$V_{CC} = V+ = V- = 0V$ , $V_{OUT} = \pm 2V$	300	500		$\Omega$	
Output Short-Circuit Current		short to $V_{CC}$ , GND or other TXD pin			$\pm 70$	mA	
<b>TIMING CHARACTERISTICS</b>							
Maximum Data Rate		$R_L = 3k\Omega$ to $7k\Omega$ , $C_L = 50pF$ to $1000pF$ , one transmitter switching	250			kbps	
Receiver Propagation Delay	$t_{PLHR}$ , $t_{PHLR}$	$C_L = 150pF$ Figure 1	All parts, normal operation	0.15		$\mu s$	
Transmitter Propagation Delay	$t_{PLHT}$ , $t_{PHLT}$	$R_L = 3k\Omega$ , $C_L = 2500pF$ , all transmitters loaded Figure 1		0.1		$\mu s$	
Transition-Region Slew Rate		$T_A = +25^\circ C$ , $V_{CC} = 3.3V$ , $R_L = 3k\Omega$ to $7k\Omega$ , $C_L = 50pF$ to $1000pF$ , measured from $-3V$ to $+3V$ or $+3V$ to $-3V$ , Figure 1	3	6	30	V/ $\mu s$	
<b>ESD AND LATCH UP PERFORMANCE</b>							
ESD-Protection Voltage		Human Body Model		$\pm 2$		kV	
Latch Up Performance				$\pm 200$		mA	

## Pin Configurations

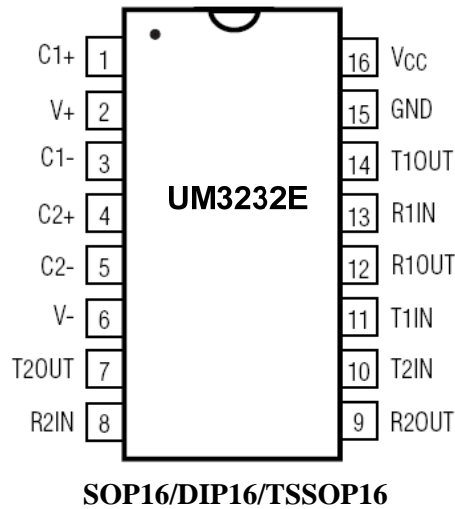

## Pin Descriptions

Pin No.	Pin Name	Function
SOP/DIP/TSSOP		
1,3	C1+, C1-	Terminals for positive charge pump capacitor
2	V+	Positive voltage generated by the charge pump
4,5	C2+, C2-	Terminals for negative charge pump capacitor
6	V-	Negative voltage generated by the charge pump
7,14	T_OUT	RS-232 Driver Outputs
8,13	R_IN	RS-232 Receiver Inputs
9,12	R_OUT	RS-232 Receiver Outputs
10,11	T_IN	RS-232 Driver Inputs
15	GND	Ground
16	V <sub>CC</sub>	+3.0V to +5.5V Supply Voltage Input

## Detailed Description

The UM3232ExE consists of three sections: charge-pump voltage converters, drivers, and receivers. The devices have internal charge pump voltage converters which allow them to operate from a +3.0V to +5.5V power supply. The charge pumps will operate with polarized or non-polarized capacitors ranging from 0.1 to 10 $\mu$ F and will generate the output voltage needed to meet the RS-232 output levels.

### RS-232 Drivers

The drivers are inverting transmitters, which accept TTL or CMOS inputs and output RS-232 signals with an inverted sense relative to the input logic levels. The UM3232ExE transmitters guarantee a 250kbps data rate with worst case loading conditions of 3k $\Omega$  and 1000pF. The transmitter outputs are protected against infinite short-circuits to ground without degradation in reliability. The instantaneous slew rate of the transmitter output is internally limited to a maximum of 30V/ $\mu$ s in order to meet the RS-232 standard.

### RS-232 Receivers

The receivers convert RS-232 input signals to CMOS-logic output levels. The receiver inputs are protected against voltage up to 30V. A 5kΩ pull down resistor to ground will commit the output of the receiver to a high state when the pin is float.

## ESD Protection

UM3232ExE devices have standard ESD protection structures incorporated on the pins to protect against electrostatic discharges encountered during assembly and handling.

## Test Circuits

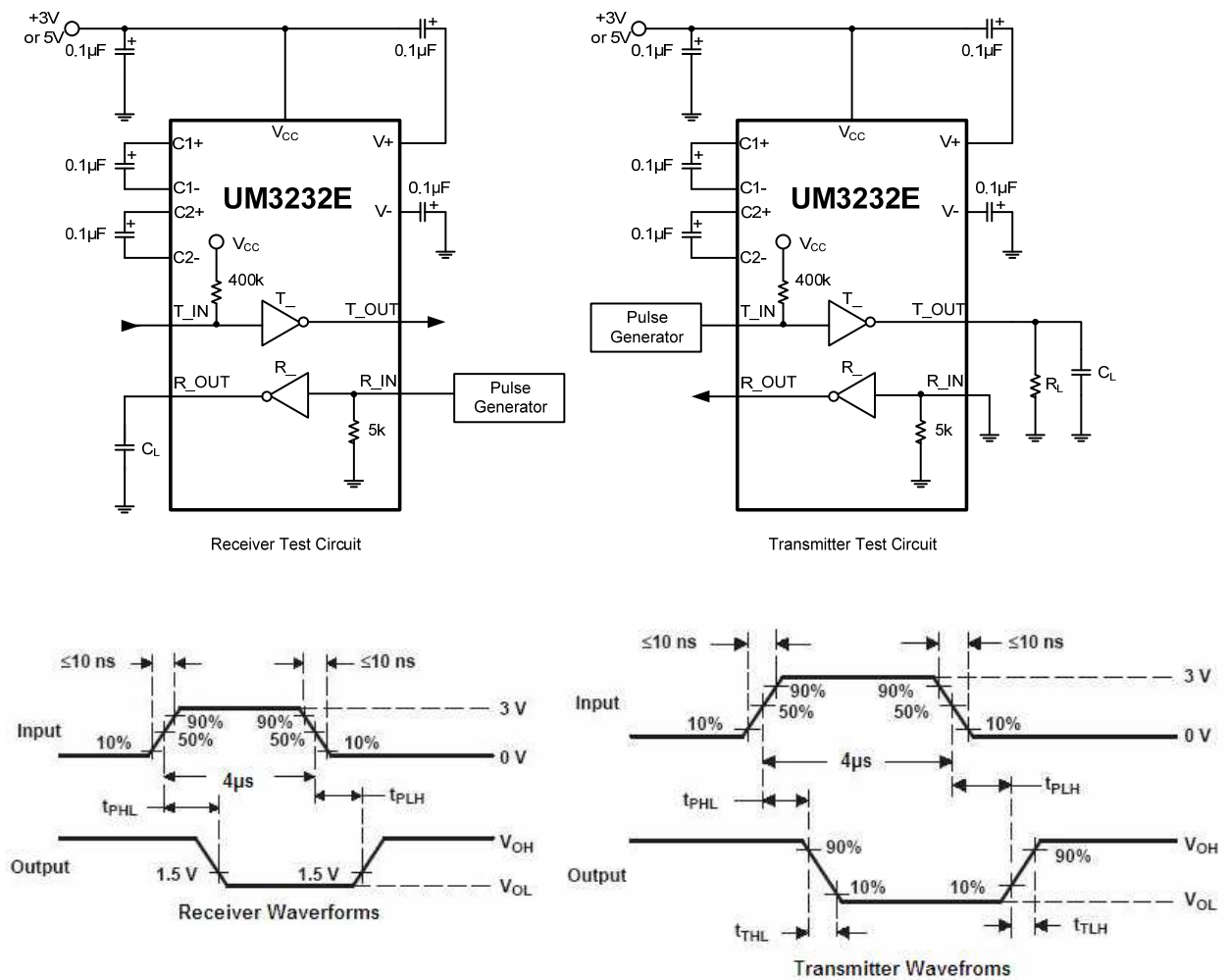
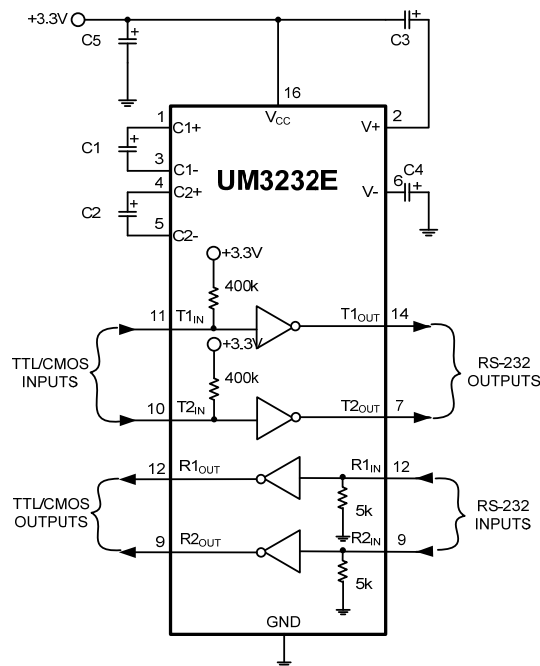

Figure 1

## Typical Operating Circuits



**Figure 2**

## Applications Information

### Capacitor Selection

The capacitor type used for C1–C4 is not critical for proper operation. The UM3232ExE, require 0.1 $\mu$ F capacitors, although in all cases capacitors up to 10 $\mu$ F can be used without harm. Ceramic dielectrics are suggested for the 0.1 $\mu$ F capacitors. When using the minimum recommended capacitor values, make sure the capacitance value does not degrade excessively as the operating temperature varies. If in doubt, use capacitors with a larger (e.g., 2x) nominal value. The capacitors' effective series resistance (ESR), which usually rises at low temperatures, influences the amount of ripple on V<sub>+</sub> and V<sub>-</sub>. Use larger capacitors (up to 10 $\mu$ F) to reduce the output impedance at V<sub>+</sub> and V<sub>-</sub>. Bypass V<sub>CC</sub> to ground with at least 0.1 $\mu$ F capacitor. In applications sensitive to power-supply noise generated by the charge pumps, decouple V<sub>CC</sub> to ground with a capacitor the same size as (or larger than) the charge pump capacitors (C1–C4).

### V<sub>+</sub> and V<sub>-</sub> as Power Supplies

A small amount of power can be drawn from V<sub>+</sub> and V<sub>-</sub>, although this will reduce both driver output swing and noise margins. Increasing the value of the charge-pump capacitors (up to 10 $\mu$ F) helps maintain performance when power is drawn from V<sub>+</sub> or V<sub>-</sub>.

### Driving Multiple Receivers

Each transmitter is designed to drive a single receiver. Transmitters can be paralleled to drive multiple receivers.

### High Data Rates

The UM3232ExE can directly interface with various 3V and 5V logic families, including ACT and HCT CMOS.

## Package Information

### UM3232ESE SOP16

#### Outline Drawing

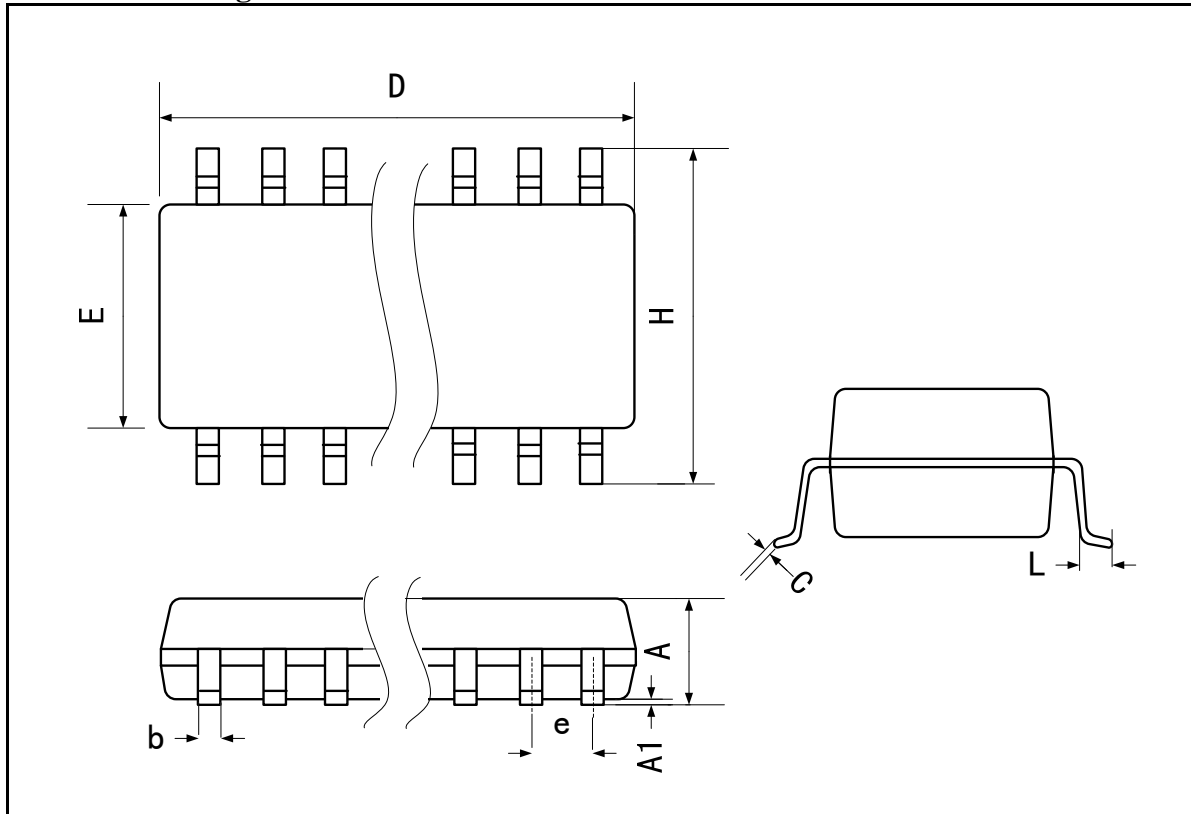

DIMENSIONS				
Symbol	MILLIMETERS		INCHES	
	Min	Max	Min	Max
A	1.35	1.75	0.053	0.069
A1	0.10	0.25	0.004	0.010
b	0.35	0.49	0.014	0.019
C	0.19	0.25	0.007	0.010
E	3.80	4.00	0.150	0.157
D (8 PIN)	4.80	5.00	0.189	0.197
D (14 PIN)	8.55	8.75	0.337	0.344
D (16 PIN)	9.80	10.00	0.386	0.394
e	1.27		0.050	
H	5.80	6.20	0.228	0.244
L	0.40	1.27	0.016	0.050

## UM3232EPE DIP16

### Outline Drawing

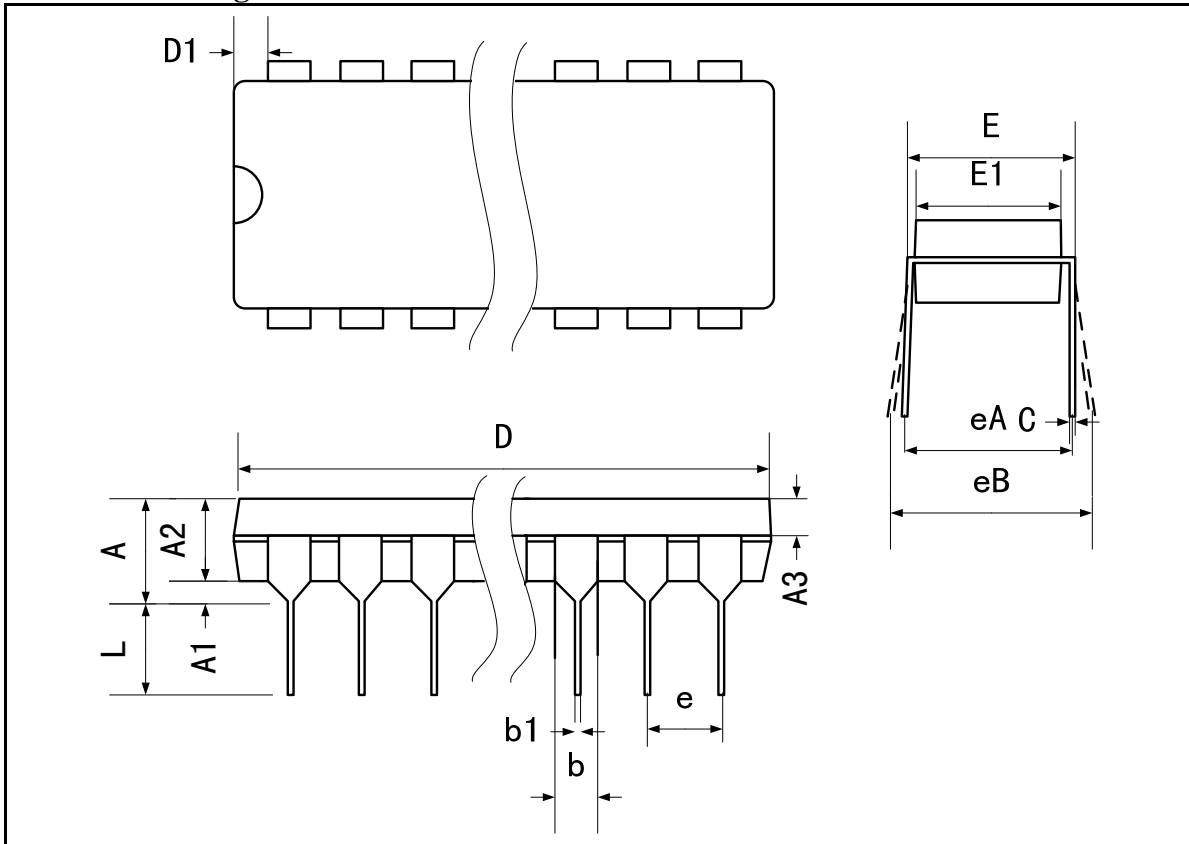

DIMENSIONS				
Symbol	MILLIMETERS		INCHES	
	Min	Max	Min	Max
A	-	5.08	-	0.200
A1	0.38	-	0.015	-
A2	3.18	4.45	0.125	0.175
A3	1.40	2.03	0.055	0.080
b	0.41	0.56	0.016	0.022
b1	1.14	1.65	0.045	0.065
C	0.20	0.30	0.008	0.012
D (8 PIN)	8.84	9.91	0.348	0.390
D (14 PIN)	18.67	19.43	0.735	0.765
D (16 PIN)	18.92	19.43	0.745	0.765
D1	0.13	2.03	0.005	0.080
E	7.62	8.26	0.300	0.325
E1	6.10	7.87	0.240	0.310
e	2.54	-	0.100	-
eA	7.62	-	0.300	-
eB	-	10.16	-	0.400
L	2.92	3.81	0.115	0.150

## UM3232EUE TSSOP16

### Outline Drawing

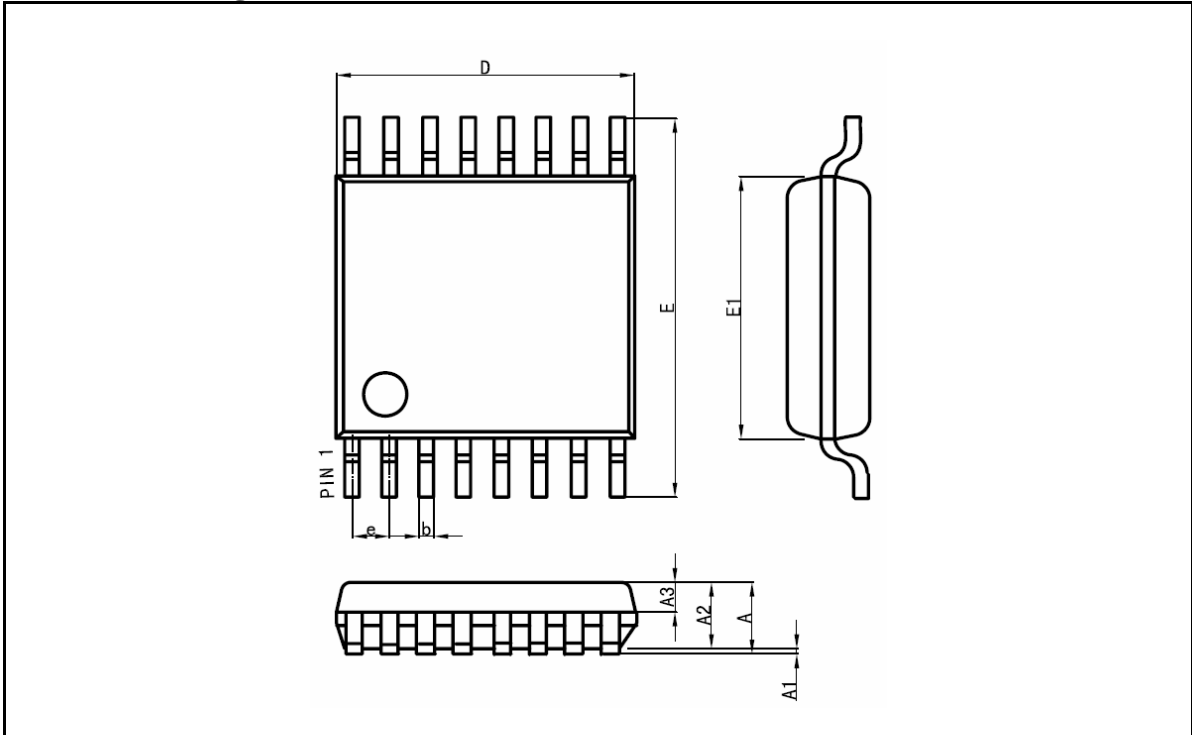

DIMENSIONS				
Symbol	MILLIMETERS		INCHES	
	Min	Max	Min	Max
A	-	1.20	-	0.047
A1	0.05	0.15	0.002	0.006
A2	0.90	1.05	0.035	0.041
A3	0.34	0.54	0.013	0.021
D	4.86	5.06	0.191	0.199
E	6.20	6.60	0.244	0.260
E1	4.30	4.50	0.169	0.177
b	0.20	0.28	0.008	0.011
e	0.65BSC		0.026BSC	

---

## IMPORTANT NOTICE

The information in this document has been carefully reviewed and is believed to be accurate. Nonetheless, this document is subject to change without notice. Union assumes no responsibility for any inaccuracies that may be contained in this document, and makes no commitment to update or to keep current the contained information, or to notify a person or organization of any update. Union reserves the right to make changes, at any time, in order to improve reliability, function or design and to attempt to supply the best product possible.



Union Semiconductor, Inc

Add: 2F, No. 3, Lane 647 Songtao Road, Shanghai 201203

Tel: 021-51093966

Fax: 021-51026018

Website: [www.union-ic.com](http://www.union-ic.com)