

0.5Ω Low-Voltage Dual SPDT Analog Switch

UM4684H CSP10 2.0 × 1.5
UM4684EEUE MSOP10

General Description

The UM4684 is a sub 1Ω (0.5Ω at 2.7V) dual SPDT analog switch designed for low voltage applications.

The UM4684 has on-resistance matching (less than 0.05Ω at 2.7V) and flatness (less than 0.2Ω at 2.7V) that are guaranteed over the entire voltage range. Additionally, low logic thresholds make the UM4684 an ideal interface to low voltage DSP control signals.

The UM4684 has fast switching speed with break-before-make guaranteed. In the ON condition, all switching elements conduct equally in both directions. OFF-isolation and crosstalk is -69dB at 100kHz.

The UM4684 is built on high-density low voltage CMOS process, and contains the additional benefit of 2000V ESD protection.

As a committed partner to the community and the environment, Union manufactures this product with lead (Pb)-free device terminations.

Applications

- Cellular Phones
- Speaker Headset Switching
- Audio And Video Signal Routing
- PCMCIA Cards
- Battery Operated Systems
- Relay Replacement
- Power Routing
- Communication Circuits

Features

- CSP10 & MSOP10 Packages
- ESD Protection > 2000V
- +1.8V to +5.5V Single Supply Operation
- NC Switch R_{ON}: 0.5Ω (+2.7V Supply)
- NO Switch R_{ON}: 0.6Ω (+2.7V Supply)
- R_{ON} Match Between Channels: 0.05Ω max (+2.7V Supply)
- R_{ON} Flatness Over Signal Range: 0.2Ω max (+2.7V Supply)
- 1.8V logic Compatibility
- Low Crosstalk: -69dB (100KHZ)
- High Off-Isolation: -69dB (100KHZ)

Ordering Information

Part Number	TEMP. RANGE	Packaging Type	Marking Code	Shipping Qty
UM4684H	-40 to 85 °C	CSP10 2.0×1.5	A	3000pcs/7 Inch Tape & Reel
UM4684EEUE	-40 to 85 °C	MSOP10	UM4684EEUE	3000pcs/13 Inch Tape & Reel

Pin Configurations

Top View

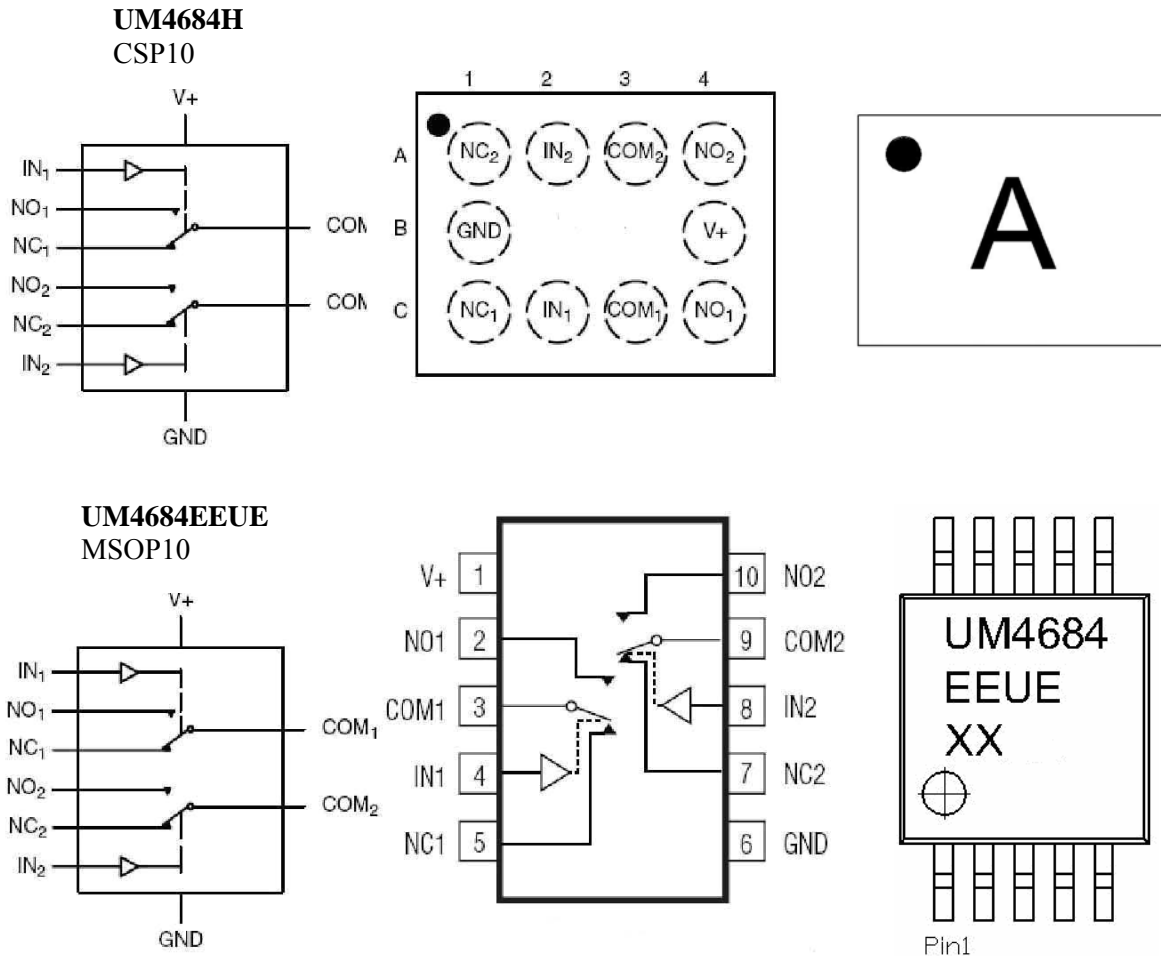

Pin Description

NAME	PIN		FUNCTION
	CSP10	MSOP-10	
NC_	A1, C1	5, 7	Analog Switch—Normally Closed Terminal
IN_	A2, C2	4, 8	Digital Control Input
COM_	A3, C3	3, 9	Analog Switch—Common Terminal
NO_	A4, C4	2, 10	Analog Switch—Normally Open Terminal
V+	B4	1	Positive Supply Voltage Input
GND	B1	6	Ground

Function Table

IN ₋	NO ₋	NC ₋
0	OFF	ON
1	ON	OFF

Absolute Maximum Ratings

Reference to GND

V₊ -0.3 to +6 V
 IN, COM, NC, NO -0.3to (V₊+ 0.3 V)
 Continuous Current (NO, NC, COM) .±300 mA
 Peak Current ±500 mA
 (Pulsed at 1 ms, 10% duty cycle)
 Storage Temperature (D Suffix) . . -65 to 150°C
 Package Solder Reflow Conditions^b
 IR/Convection. 250°C
 ESD per Method 3015.7 > 2 kV

Power Dissipation (Packages)^c

CSP10 457 mW

Notes:

- Signals on NC, NO, or COM or IN exceeding V₊ will be clamped by internal diodes. Limit forward diode current to maximum current ratings.
- Refer to IPC/JEDEC (J-STD-020B).
- All bumps welded or soldered to PC Board.
- Derate 5.7 mW/°C above 70°C.

Stresses beyond those listed under “Absolute Maximum Ratings” may cause permanent damage to the device. These are stress ratings only and functional operation of the device at these or any other conditions beyond those indicated in the operational sections of the specifications are not implied. Exposure to absolute maximum rating conditions for extended periods may affect device reliability.

Electrical Characteristics ($V_+ = 3V$, $\pm 10\%$ deviation, $V_{IN} = 0.5$ or $1.4V^e$)

Parameter	Symbol	Test Conditions Otherwise Unless Specified	Temp ^a	Limits (-40 to 85 °C)			Unit
				Min ^b	Typ ^c	Max ^b	
Analog Switch							
Analog Signal Range ^d	V_{NO} V_{NC} V_{COM}		Full	0		V_+	V
On-Resistance ^d	R_{on}	$V_+ = 2.7V$, $V_{com} = 0.6/1.5V$, $I_{NO}, I_{NC} = 100mA$	Room Full		0.5	0.8 1.0	Ω
R_{ON} Flatness ^d	R_{on} Flatness		Room			0.15	
On-Resistance Match Between Channels ^d	$\Delta r_{DS(on)}$		Room			0.05	
Switch Off Leakage Current	$I_{NO(off)}$, $I_{NC(off)}$	$V_+ = 3.3V$, $V_{NO}, V_{NC} = 0.3V / 3V$, $V_{COM} = 3V / 0.3V$	Room Full	-2 -20		2 20	nA
	$I_{COM(off)}$		Room Full	-2 -20		2 20	
Channel-On Leakage Current	$I_{COM(on)}$	$V_+ = 3.3V$, $V_{NO}, V_{NC} = V_{COM} = 0.3V / 3V$	Room Full	-2 -20		2 20	
Digital Control							
Input High Voltage ^d	V_{INH}		Full	1.4			V
Input Low Voltage	V_{INL}		Full			0.5	
Input Capacitance	C_{in}		Full		10		pF
Input Current	I_{INL} or I_{INH}	$V_{IN} = 0$ or V_+	Full	-1		1	μA
Dynamic Characteristics							
Turn-On Time	t_{ON}	V_{NO} or $V_{NC} = 2.0V$, $R_L = 50\Omega$, $C_L = 35pF$	Room Full		52	82 90	ns
Turn-Off Time	t_{OFF}		Room Full		43	73 78	
Break-Before-Make Time	t_d	V_{NO} or $V_{NC} = 2.0V$, $R_L = 50\Omega$, $C_L = 35pF$	Full	1	6		ns
Charge Injection ^d	Q_{INJ}	$C_L = 1nF$, $V_{GEN} = 1.5V$ $R_{GEN} = 0\Omega$	Room		21		pC
Off-Isolation ^d	O_{IRR}	$R_L = 50\Omega$, $C_L = 5Pf$	Room		-69		dB

Crosstalk ^d	X _{TALK}	f = 100KHz	Room		-69		
-3dB Bandwidth	BW	R _L = 50Ω, C _L = 5pF	Room		20		MHz
NO NC Off Capacitance ^d	C _{NO(off)} C _{NC(off)}	V _{IN} = 0 or V ₊ , f = 1MHz	Room Room		145 145		pF
Channel On Capacitance ^d	C _{NO(on)} C _{NC(on)}		Room Room		406 406		
Power Supply							
Power Supply Range	V ₊		Full	1.8		5.5	V
Power Supply Current	I ₊	V _{IN} = 0 or V ₊	Room Full		0.00 1	1.0 1.0	μA

Notes:

- Room = 25°C, Full = as determined by the operating suffix.
- Typical values are for design aid only, not guaranteed nor subject to production testing.
- The algebraic convention whereby the most negative value is a minimum and the most positive a maximum, is used in this data sheet.
- Guarantee by design, nor subjected to production test.
- V_{IN} = input voltage to perform proper function.

Typical Operating Characteristics

Ron vs.Vcom and Supply Voltage

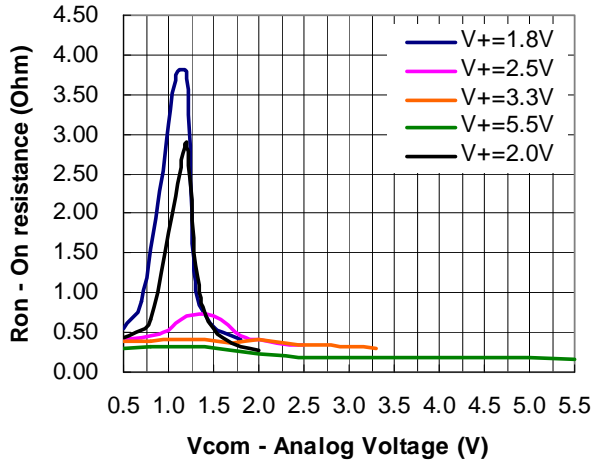

Ron vs.Vcom and Temperature (NC1)

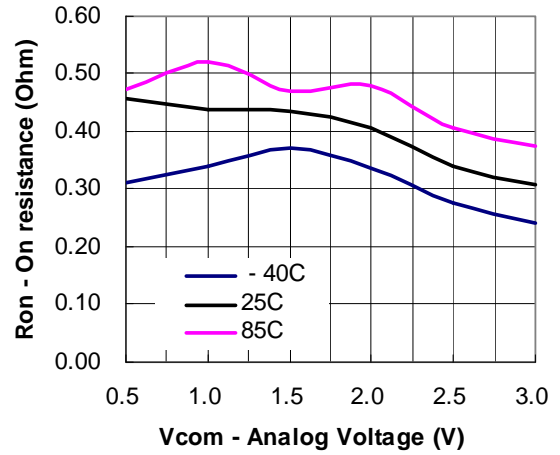

Supply Current vs. Input Switching Frequency

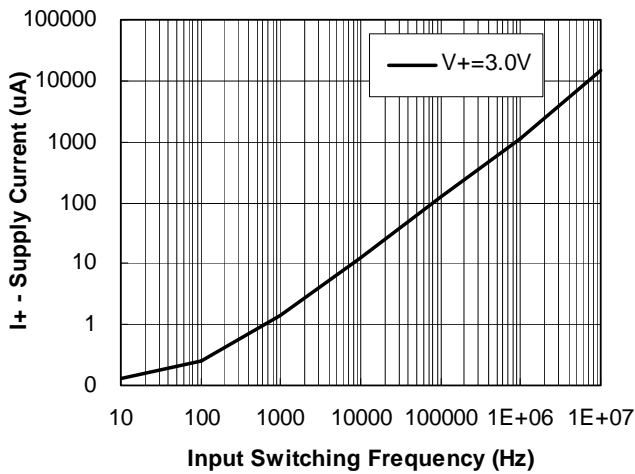

Switching Threshold vs. Supply Voltage (V)

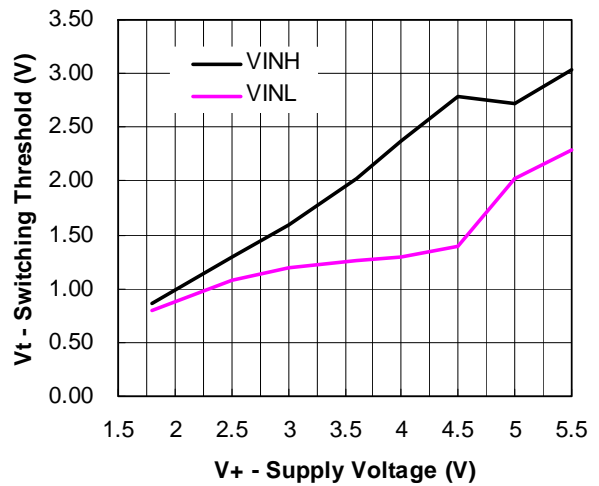

Bandwidth vs. Frequency

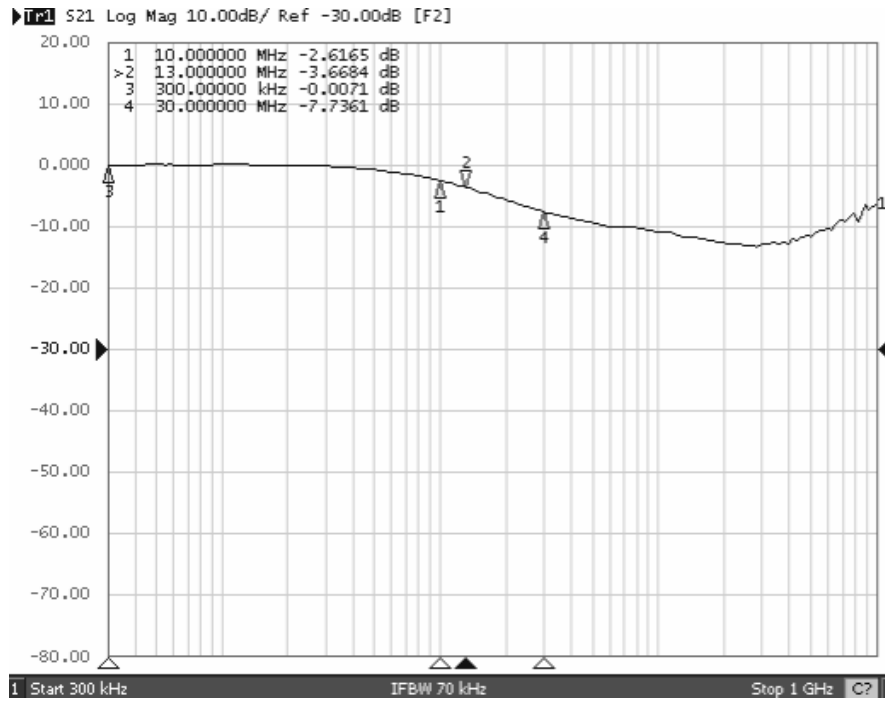

Off-isolation vs. Frequency

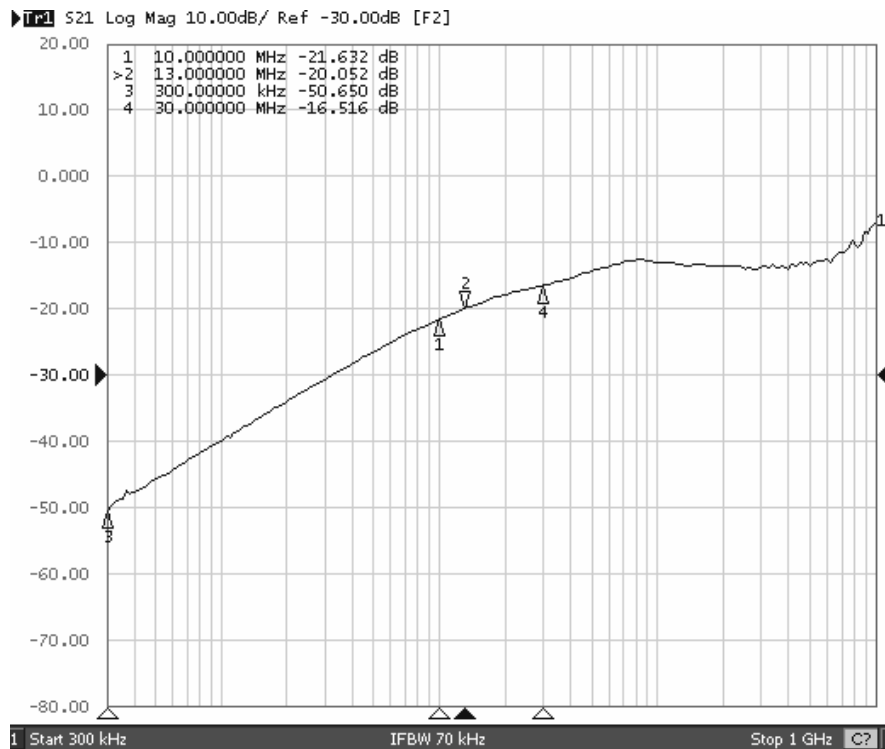

Test Circuits/Timing Diagrams

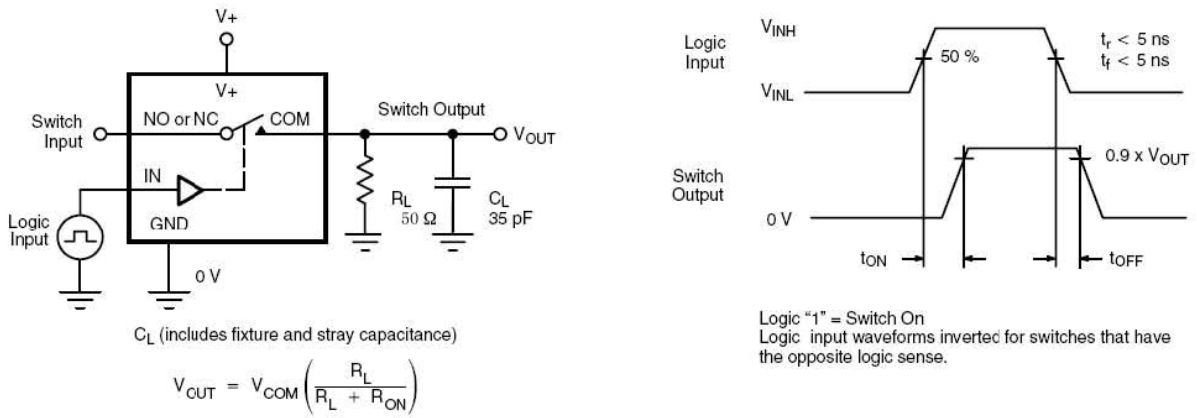

FIGURE 1. Switching Time

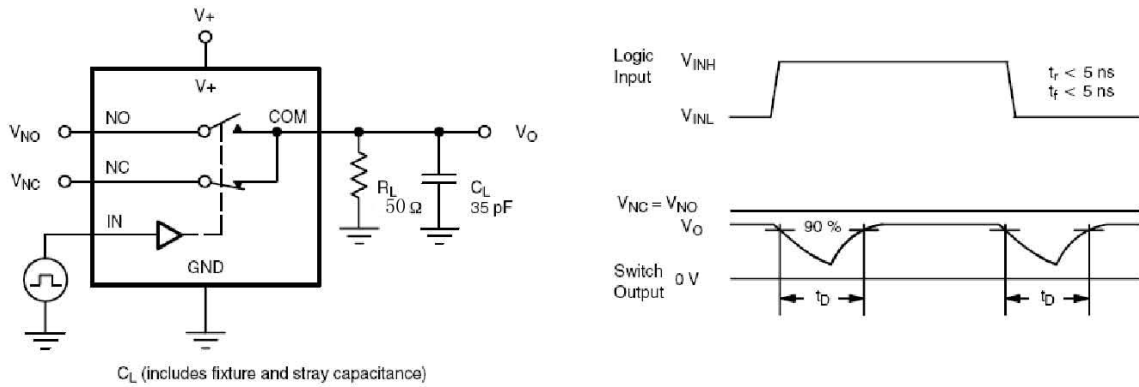

FIGURE 2. Break-Before-Make Interval

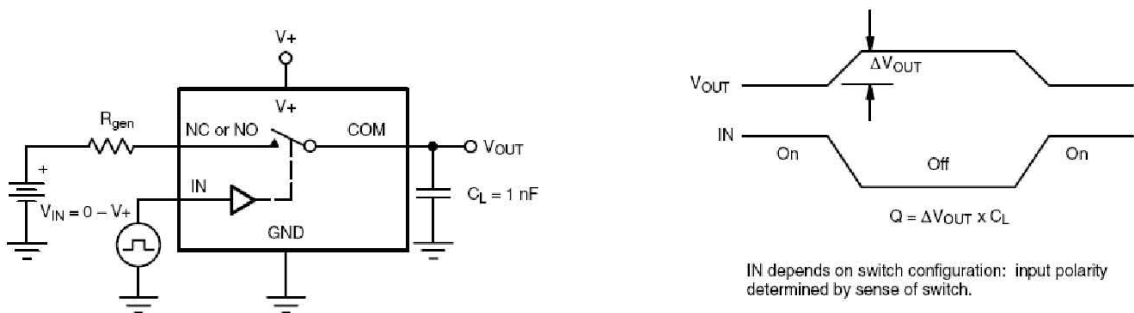

FIGURE 3. Charge Injection

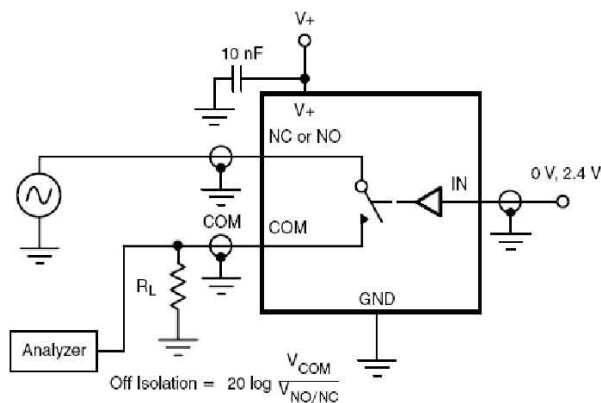

FIGURE 4. Off-Isolation

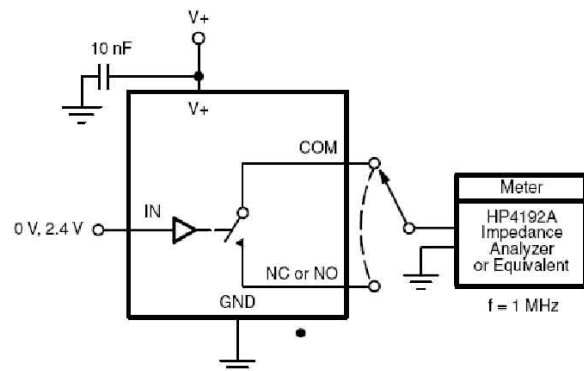

FIGURE 5. Channel Off/On Capacitance

Applications Information

Digital Control Inputs

The UM4684 logic inputs accept up to +5.5V regardless of supply voltage. For example, with a +3.3V supply, IN₋ may be driven low to GND and high to 5.5V. Driving IN₋ rail-to-rail minimizes power consumption. Logic levels for a +1.8V supply are 0.5V (low) and 1.4V (high).

Analog Signal Levels

Analog signals that range over the entire supply voltage (V₊ to GND) is passed with very little change in on-resistance (see Typical Operating Characteristics). The switches are bidirectional, so the NO₋, NC₋, and COM₋ pins can be either inputs or outputs.

Caution

Do not exceed the absolute maximum ratings because stresses beyond the listed ratings may cause permanent damage to devices.

Proper power-supply sequencing is recommended for all CMOS devices. Always apply V₊ before applying analog signals, especially if the analog signal is not current limited. If this sequencing is not possible, and if the analog inputs are not current limited to <20mA, add a small signal diode (D1) as shown in Figure 6. Adding a protection diode reduces the analog range to a diode drop (about 0.7V) below V₊ (for D1). RON increases slightly at low supply voltages. Maximum supply voltage (V₊) must not exceed +6V. Protection diode D1 also protects against some over voltage situations. No damage will result on Figure 6's circuit if the supply voltage is below the absolute maximum rating applied to an analog signal pin.

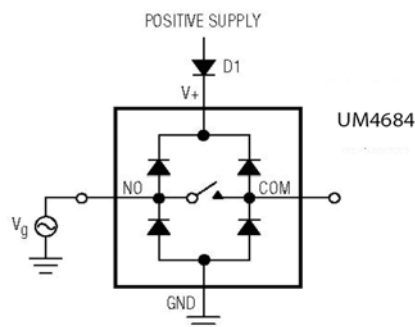
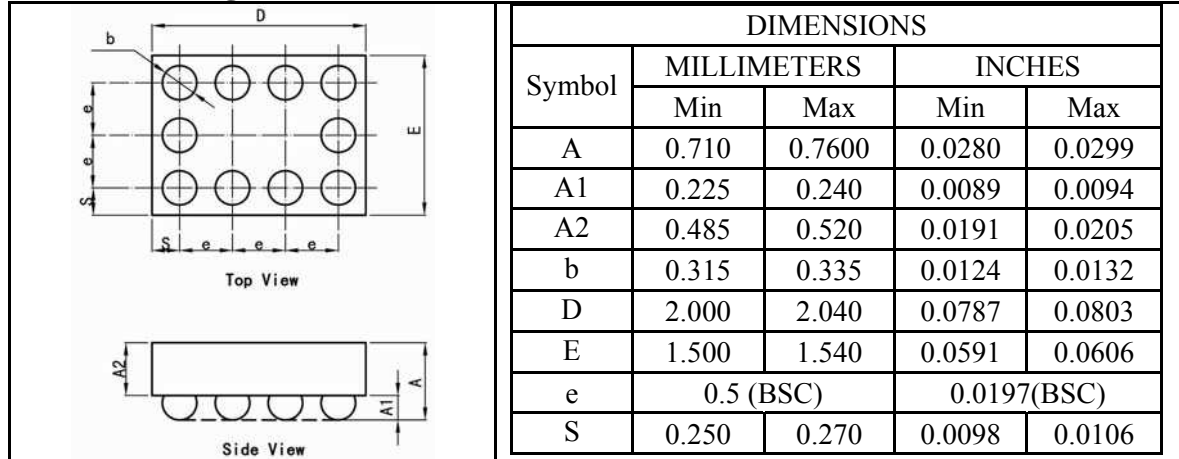

Figure 6

Package Information

UM4684H CSP10 2.0×1.5

Outline Drawing



Land Pattern

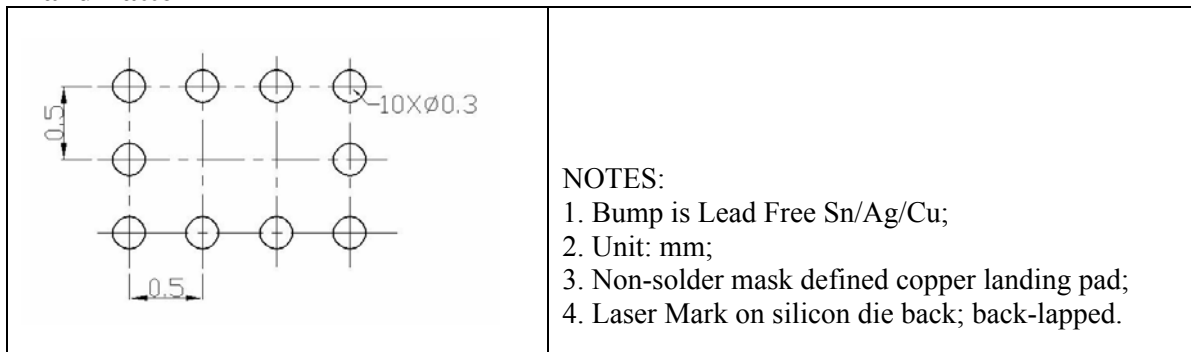

Tape and Reel Orientation

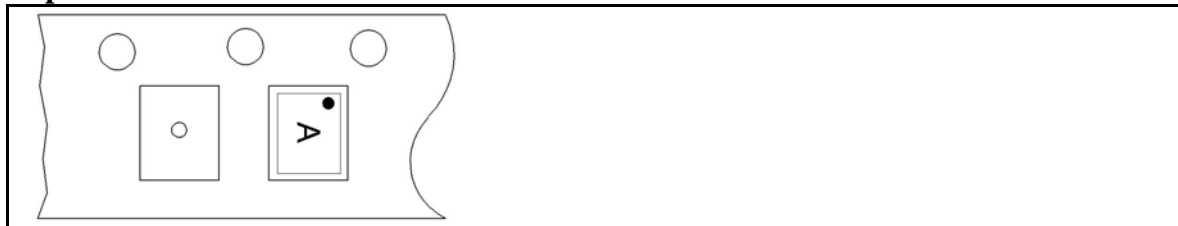

UM4684EEUE MSOP10

Outline Drawing

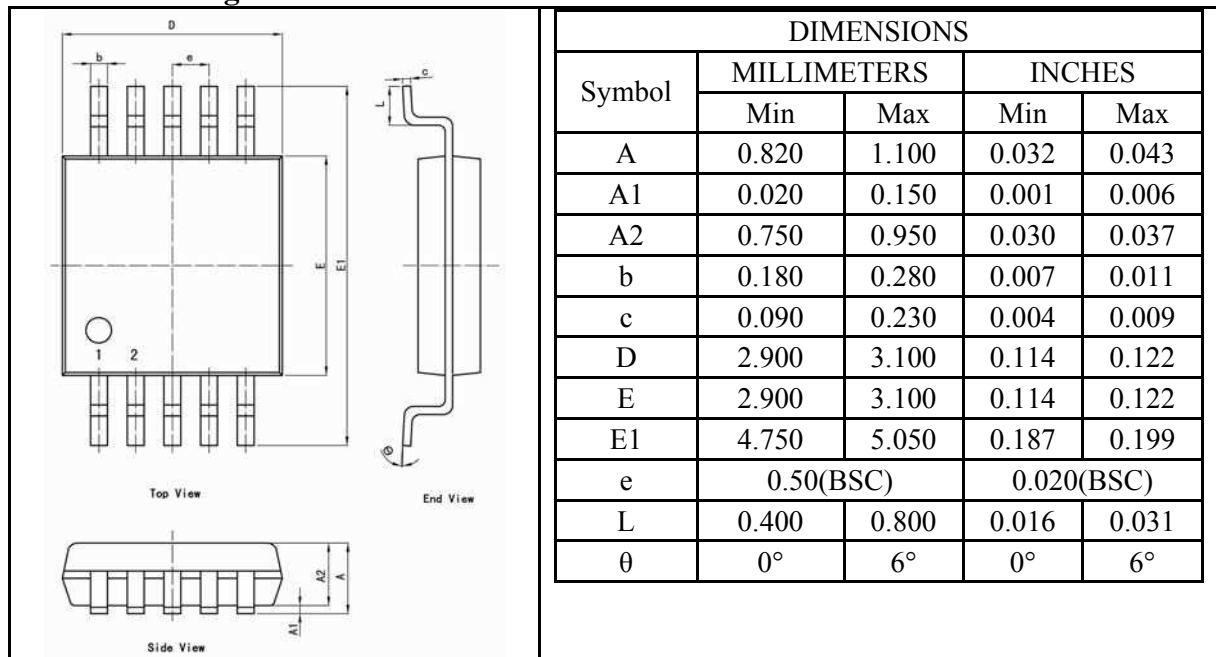

Land Pattern

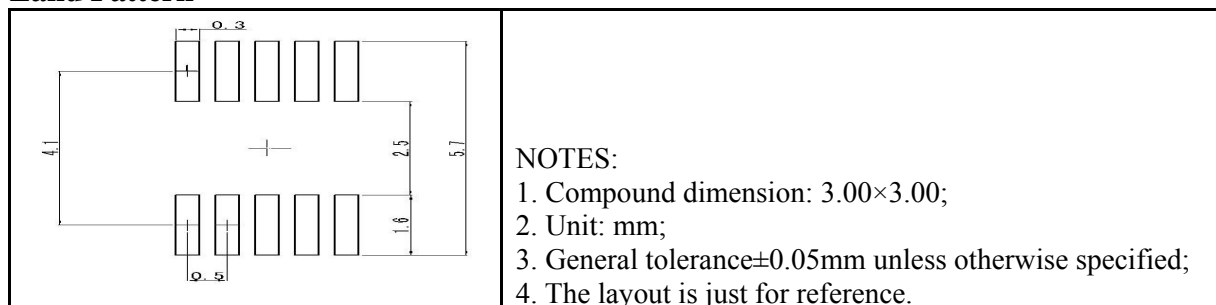

Tape and Reel Orientation

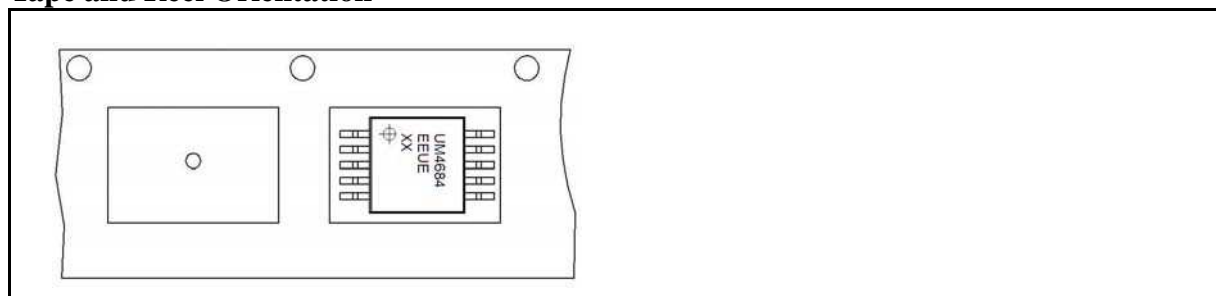

IMPORTANT NOTICE

The information in this document has been carefully reviewed and is believed to be accurate. Nonetheless, this document is subject to change without notice. Union assumes no responsibility for any inaccuracies that may be contained in this document, and makes no commitment to update or to keep current the contained information, or to notify a person or organization of any update. Union reserves the right to make changes, at any time, in order to improve reliability, function or design and to attempt to supply the best product possible.



Union Semiconductor, Inc

Add: 2F, No. 3, Lane 647 Songtao Road, Shanghai 201203

Tel: 021-51093966

Fax: 021-51026018

Website: www.union-ic.com