

4.5Ω 300MHz Bandwidth Dual SPDT Analog Switch

UM4258Q QFN10 1.80×1.40

General Description

The UM4258Q low-voltage, low on-resistance (R_{ON}), dual single-pole/double-throw (SPDT) analog switch operates from a single +1.8V to +5.5V supply. The device is designed for USB 1.1/2.0 and audio switching applications.

The UM4258Q features two 4.5Ω R_{ON} (max) SPDT switches with 1.2Ω flatness and 0.3Ω matching between channels. The switch offers break-before-make switching (1ns) with $t_{ON} < 80ns$ and $t_{OFF} < 40ns$ at +2.7V. The digital logic inputs are +1.8V logic compatible with a +2.7V to +3.6V supply.

The UM4258Q is packaged in a 1.80mm × 1.40mm QFN10 package, which significantly reducing the required PC board area.

Applications

- USB 1.1/2.0 Signal Switching Circuits
- Battery-Operated Equipment
- Audio/Video-Signal Routing
- Headphone Switching
- Low-Voltage Data-Acquisition Systems
- Sample-and-Hold Circuits
- Cell Phones
- PDAs

Features

- 2ns (max) Differential Skew
- -3dB Bandwidth: 300MHz
- Low 15pF On-Channel Capacitance
- Single-Supply Operation from +1.8V to +5.5V
- 4.5Ω R_{ON} (max) Switches
- 0.3Ω (max) R_{ON} Match (+3.0V Supply)
- 1.2Ω (max) Flatness (+3.0V Supply)
- Rail-to-Rail Signal Handling
- High Off-Isolation: -55dB (10MHz)
- Low Crosstalk: -80dB (10MHz)
- Low Distortion: 0.03%
- +1.8V CMOS-Logic Compatible
- < 0.5nA Leakage Current at +25°C

Pin Configurations

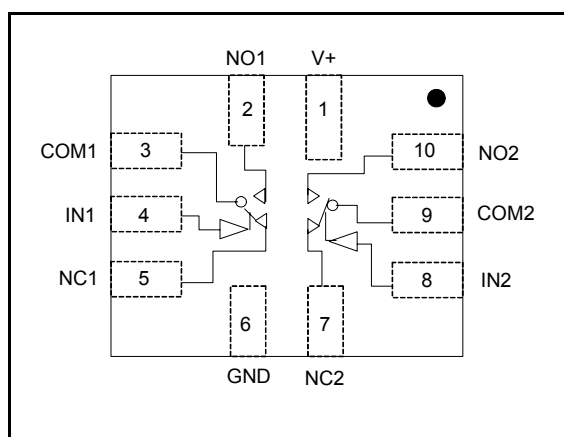

Top View

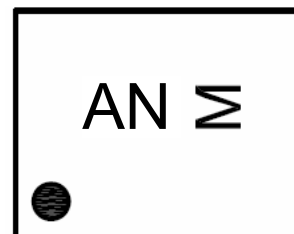

M: Month Code
UM4258Q
QFN10 1.80×1.40

Pin Description

Pin	Name	Function
UM4258Q		
7	NC2	Analog Switch 2-Normally Closed Terminal
8	IN2	Analog Switch 2-Digital Control Input
9	COM2	Analog Switch 2 –Common Terminal
10	NO2	Analog Switch 2-Normally Open Terminal
6	GND	Ground Connection
1	V ₊	Positive Supply Voltage
5	NC1	Analog Switch 1-Normally Closed Terminal
4	IN1	Analog Switch 1-Digital Control Input
3	COM1	Analog Switch 1 –Common Terminal
2	NO1	Analog Switch 1-Normally Open Terminal

Ordering Information

Part Number	Packaging Type	Marking Code	Shipping Qty
UM4258Q	QFN10 1.80×1.40	AN	3000pcs/7 Inch Tape & Reel

Function Table

IN __	NO __	NC __
0	OFF	ON
1	ON	OFF

Absolute Maximum Ratings

Symbol	Parameter	Limit	Unit	
V ₊	Supply Voltage	- 0.3 to + 6.0	V	
V _S	DC Switch Voltage (Note1)	- 0.3 to (V ₊ + 0.3)		
IN __	DC IN Voltage	- 0.3 to + 6.0		
I _o	Continuous Current (COM __ , NO __ , NC __)	±100	mA	
I _p	Peak Current (Pulsed at 1ms, 10% duty cycle)	±200		
T _O	Operating Temperature Range	- 40 to +85	°C	
T _J	Junction Temperature	+150		
T _{STG}	Storage Temperature Range	- 65 to +150		
T _L	Junction Lead Temperature (Soldering, 10seconds)	+300		
T _{Bump}	Bump Temperature (Soldering)	Infrared (15s)		+220
		Vapor Phase (60s)		+215
P _D	Continuous Power Dissipation @ +70°C	909	mW	
ESD	ESD Method 3015.7	>2000	V	

Note1: Signals on COM_{_}, NO_{_}, or NC_{_} exceeding V₊ or GND are clamped by internal diodes. Limit forward-diode current to maximum current rating.

DC Electrical Characteristics (Single +3V Supply)

($V_+ = +2.7V$ to $+3.6V$, $V_{IH} = +1.4V$, $V_{IL} = +0.5V$, $T_A = T_{MIN}$ to T_{MAX} , unless otherwise noted. Typical values are at $V_+ = +3.0V$, $T_A = +25^\circ C$) (Notes 2,3)

Symbol	Parameter	Test Conditions	Temp	Limits (-40 to 85 °C)			Unit
				Min	Typ	Max	
DC Electrical Characteristics							
$V_{COM_}$ $V_{NO_}$ $V_{NC_}$	Analog Signal Range		Full	0		V_+	V
V_+	Power Supply Range		Full	1.8		5.5	V
I_+	Supply Current	$V_+ = +5.5V$, $V_{IN_} = 0V$ or V_+	Full			1	μA
I_{COM_ON}	COM_On Leakage Current (Note7)	$V_+ = +3.6V$, $V_{COM_} = 0.3V, 3.3V$; $V_{NO_}$ or $V_{NC_} = 0.3V, 3.3V$, or floating	Room Full	-1 -2	+0.01	+1 +2	nA
I_{OFF}	OFF State Leakage Current (Note7)	$V_+ = +3.6V$, $V_{COM_} = 0.3V, 3.3V$; $V_{NO_}$ or $V_{NC_} = 3.3V, 0.3V$	Room Full	-0.5 -1	+0.01	+0.5 +1	nA
V_{IH}	Input High Voltage		Full	1.4			V
V_{IL}	Input Low Voltage		Full			0.5	V
I_{IN}	Input Leakage Current	$V_+ = +3.6V$, $V_{IN_} = 0$ or $5.5V$	Full	-100		+100	nA
R_{ON}	On-Resistance (Note4)	$V_+ = +2.7V$, $I_{COM_} = 10mA$; $V_{NO_}$ or $V_{NC_} = 1.5V$	Room		3.0	4.5	Ω
			Full			5	
ΔR_{ON}	On Resistance Match Between Channels (Notes 4,5)	$V_+ = +2.7V$, $I_{COM_} = 10mA$; $V_{NO_}$ or $V_{NC_} = 1.5V$	Room		0.1	0.3	Ω
			Full			0.4	
R_{FLAT}	On Resistance Flatness (Note6)	$V_+ = +2.7V$, $I_{COM_} = 10mA$; $V_{NO_}$ or $V_{NC_} = 1.0V, 1.5V, 2.0V$	Room		0.6	1.2	Ω
			Full			1.5	

AC Electrical Characteristics (Single +3V Supply)

($V_+ = +2.7V$ to $+3.6V$, $V_{IH} = +1.4V$, $V_{IL} = +0.5V$, $T_A = T_{MIN}$ to T_{MAX} , unless otherwise noted. Typical values are at $V_+ = +3.0V$, $T_A = +25^\circ C$) (Notes 2,3)

Symbol	Parameter	Test Conditions	Temp	Limits (-40 to 85 °C)			Unit
				Min	Typ	Max	
AC Electrical Characteristics							
t_{ON}	Turn-On Time	$V_{NO_}, V_{NC_} = 1.5V$; $R_L = 300\Omega$, $C_L = 35pF$, Figure1; $V_{IH} = 1.5V$, $V_{IL} = 0V$	Room Full		40	80 100	ns
t_{OFF}	Turn-Off Time	$V_{NO_}, V_{NC_} = 1.5V$; $R_L = 300\Omega$, $C_L = 35pF$, Figure1; $V_{IH} = 1.5V$, $V_{IL} = 0V$	Room Full		20	40 50	ns
t_{BBM}	Break Before Make Time (Note7)	$V_{NO_}, V_{NC_} = 1.5V$; $R_L = 300\Omega$, $C_L = 35pF$, Figure2	Room Full	1	8		ns
t_{SKEW}	Skew (Note7)	$R_S = 39\Omega$, $C_L = 50pF$, Figure3	Full		0.15	2	ns
Q_{INJ}	Charge Injection	$C_L = 1.0 nF$, Figure 4 $V_{GEN} = 1.5V$, $R_{GEN} = 0\Omega$	Room		5		pC
V_{ISO}	Off Isolation	$f = 10 MHz$; $V_{NO_}, V_{NC_} = 1V_{P-P}$; $R_L = 50\Omega$, $C_L = 5pF$, Figure5	Room		-55		dB
		$f = 1 MHz$; $V_{NO_}, V_{NC_} = 1V_{P-P}$; $R_L = 50\Omega$, $C_L = 5pF$, Figure5			-80		
V_{CT}	Crosstalk (Note8)	$f = 10 MHz$; $V_{NO_}, V_{NC_} = 1V_{P-P}$; $R_L = 50\Omega$, $C_L = 5pF$, Figure5	Room		-80		dB
		$f = 1 MHz$; $V_{NO_}, V_{NC_} = 1V_{P-P}$; $R_L = 50\Omega$, $C_L = 5pF$, Figure5			-110		
BW	-3 dB Bandwidth	Signal=0dBm, $R_L = 50\Omega$, $C_L = 5pF$, Figure5	Room		300		MHz
THD	Total Harmonic Distortion	$R_L = 600\Omega$ $V_{COM} = 2V_{P-P}$	Room		0.03		%
Capacitance							
$C_{NO_ (OFF)}$ $C_{NC_ (OFF)}$	NO_, NC_ Off Capacitance	$f = 1MHz$, Figure 6	Room		9		pF
$C_{(ON)}$	Switch On Capacitance	$f = 1MHz$, Figure 6	Room		15		pF

DC Electrical Characteristics (Single +5V Supply)

($V_+ = +4.2V$ to $+5.5V$, $V_{IH} = +2.0V$, $V_{IL} = +0.8V$, $T_A = T_{MIN}$ to T_{MAX} , unless otherwise noted. Typical values are at $V_+ = +5.0V$, $T_A = +25^\circ C$) (Notes 2,3)

Symbol	Parameter	Test Conditions	Temp	Limits (-40 to 85 °C)			Unit
				Min	Typ	Max	
DC Electrical Characteristics							
$V_{COM_}$ $V_{NO_}$ $V_{NC_}$	Analog Signal Range		Full	0		V_+	V
V_+	Power Supply Range		Full	1.8		5.5	V
I_+	Supply Current	$V_+ = +5.5V$, $V_{IN_} = 0V$ or V_+	Full			1	μA
I_{COM_ON}	COM_On Leakage Current (Note7)	$V_+ = +5.5V$, $V_{COM_} = 1.0V, 4.5V$; $V_{NO_}$ or $V_{NC_} = 1.0V, 4.5V$, or floating	Room Full	-1 -2	+0.01	+1 +2	nA
I_{OFF}	OFF State Leakage Current (Note7)	$V_+ = +5.5V$, $V_{COM_} = 1.0V, 4.5V$; $V_{NO_}$ or $V_{NC_} = 1.0V, 4.5V$	Room Full	-0.5 -1	+0.01	+0.5 +1	nA
V_{IH}	Input High Voltage		Full	2.0			V
V_{IL}	Input Low Voltage		Full			0.8	V
I_{IN}	Input Leakage Current	$V_+ = +5.5V$, $V_{IN_} = 0$ or V_+	Full	-100		+100	nA
R_{ON}	On-Resistance (Note4)	$V_+ = +4.2V$, $I_{COM_} = 10mA$; $V_{NO_}$ or $V_{NC_} = 3.5V$	Room		1.7	3	Ω
			Full			3.5	
ΔR_{ON}	On Resistance Match Between Channels (Notes 4,5)	$V_+ = +4.2V$, $I_{COM_} = 10mA$; $V_{NO_}$ or $V_{NC_} = 3.5V$	Room		0.1	0.3	Ω
			Full			0.4	
R_{FLAT}	On Resistance Flatness (Note6)	$V_+ = +4.2V$, $I_{COM_} = 10mA$; $V_{NO_}$ or $V_{NC_} = 1.0V, 2.0V, 3.5V$	Room		0.4	1.2	Ω
			Full			1.5	

AC Electrical Characteristics (Single +5V Supply)

($V_+ = +4.2V$ to $+5.5V$, $V_{IH} = +2.0V$, $V_{IL} = +0.8V$, $T_A = T_{MIN}$ to T_{MAX} , unless otherwise noted. Typical values are at $V_+ = +5.0V$, $T_A = +25^\circ C$) (Notes 2,3)

Symbol	Parameter	Test Conditions	Temp	Limits (-40 to 85 °C)			Unit
				Min	Typ	Max	
AC Electrical Characteristics							
t_{ON}	Turn-On Time	$V_{NO_}, V_{NC_} = 3.0V$; $R_L = 300\Omega$, $C_L = 35pF$, Figure1;	Room Full		30	80 100	ns
t_{OFF}	Turn-Off Time	$V_{NO_}, V_{NC_} = 3.0V$; $R_L = 300\Omega$, $C_L = 35pF$, Figure1;	Room Full		20	40 50	ns
t_{BBM}	Break Before Make Time (Note7)	$V_{NO_}, V_{NC_} = 3.0V$; $R_L = 300\Omega$, $C_L = 35pF$, Figure2	Room Full	1	8		ns
t_{SKEW}	Skew (Note7)	$R_S = 39\Omega$, $C_L = 50pF$, Figure3	Full		0.15	2	ns
Q_{INJ}	Charge Injection	$C_L = 1.0 nF$, Figure 4 $V_{GEN} = 1.5V$, $R_{GEN} = 0\Omega$	Room		9		pC
V_{ISO}	Off Isolation	$f = 10 MHz$; $V_{NO_}, V_{NC_} = 1V_{P-P}$; $R_L = 50\Omega$, $C_L = 5pF$, Figure5	Room		-55		dB
		$f = 1 MHz$; $V_{NO_}, V_{NC_} = 1V_{P-P}$; $R_L = 50\Omega$, $C_L = 5pF$, Figure5			-80		
V_{CT}	Crosstalk (Note8)	$f = 10 MHz$; $V_{NO_}, V_{NC_} = 1V_{P-P}$; $R_L = 50\Omega$, $C_L = 5pF$, Figure5	Room		-80		dB
		$f = 1 MHz$; $V_{NO_}, V_{NC_} = 1V_{P-P}$; $R_L = 50\Omega$, $C_L = 5pF$, Figure5			-110		
BW	-3 dB Bandwidth	Signal=0dBm, $R_L = 50\Omega$, $C_L = 5pF$, Figure5	Room		300		MHz
THD	Total Harmonic Distortion	$R_L = 600\Omega$ $V_{COM} = 2V_{P-P}$	Room		0.03		%
Capacitance							
$C_{NO_ (OFF)}$ $C_{NC_ (OFF)}$	NO_, NC_ Off Capacitance	$f = 1MHz$, Figure 6	Room		9		pF
$C_{(ON)}$	Switch On Capacitance	$f = 1MHz$, Figure 6	Room		15		pF

Note 2: The parts are 100% tested at $+25^\circ C$ only, and guaranteed by design over the specified temperature range.

Note 3: The algebraic convention used in this data sheet is where the most negative value is a minimum and the most positive value is a maximum.

Note 4: Guaranteed by design.

Note 5: $\Delta R_{ON} = R_{ON(MAX)} - R_{ON(MIN)}$.

Note 6: Flatness is defined as the difference between the maximum and minimum value of on-resistance as measured over the specified analog signal ranges.

Note 7: Guaranteed by design.

Note 8: Between any two switches.

Typical Operating Characteristics

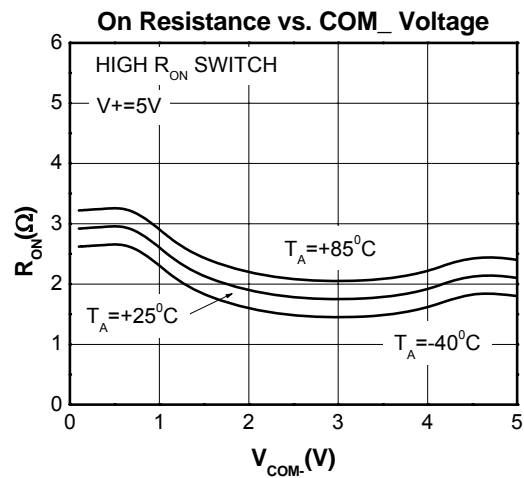
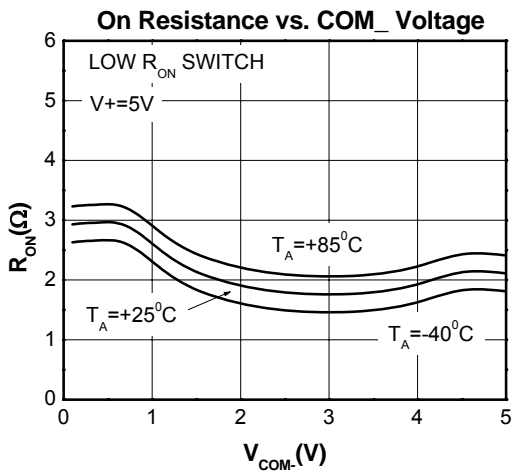
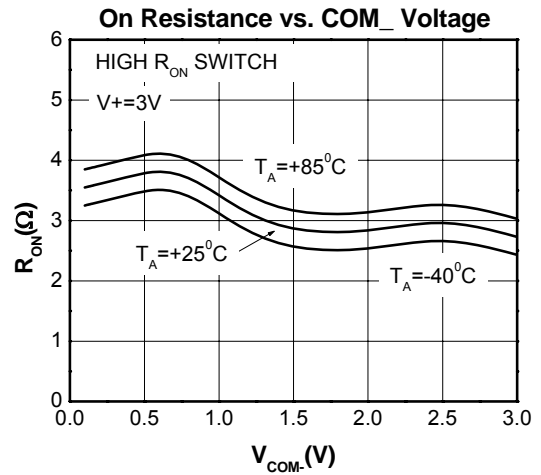
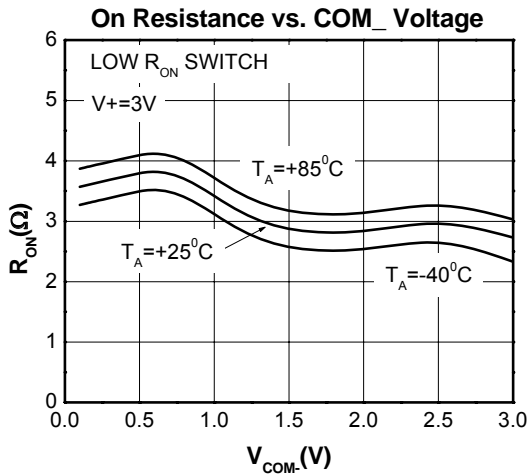
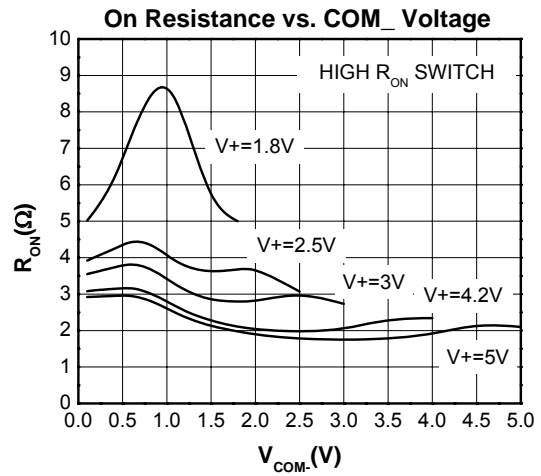
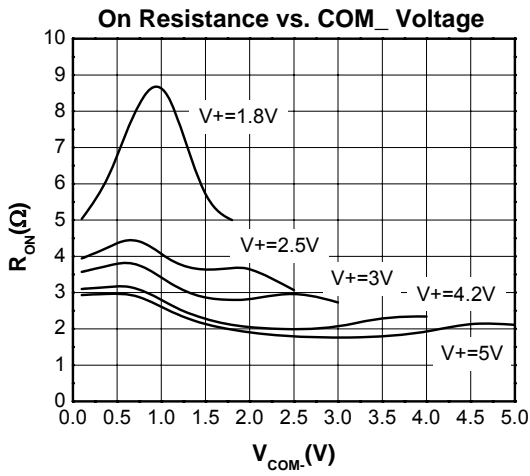

Typical Operating Characteristics

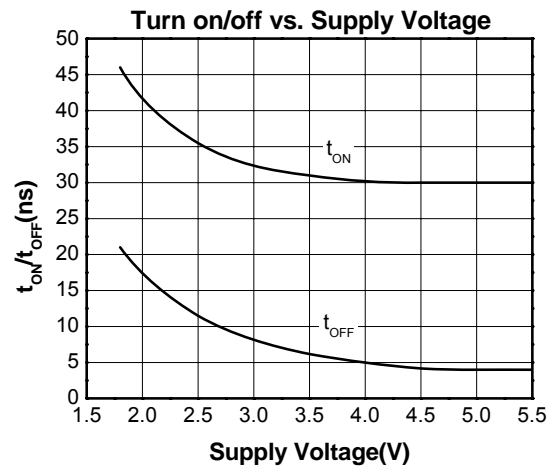
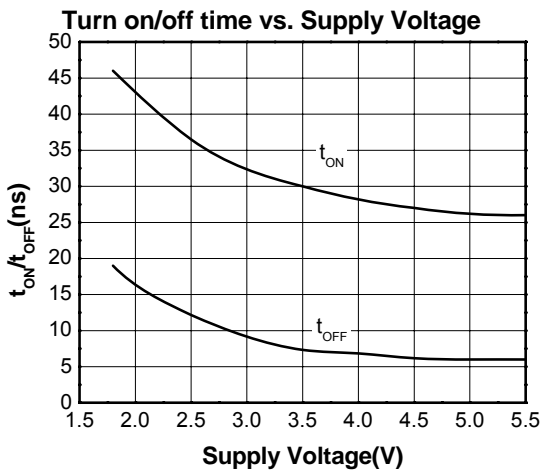
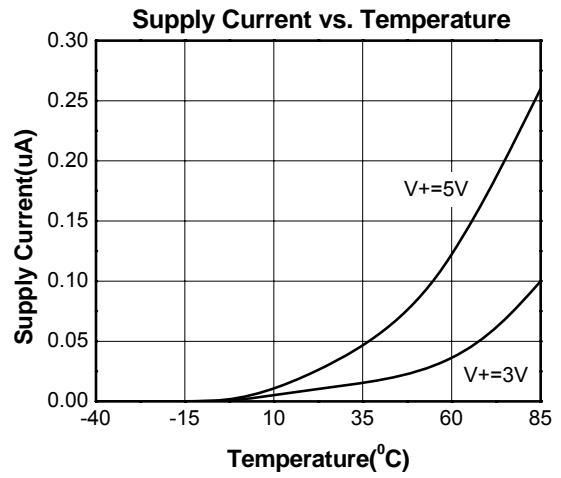
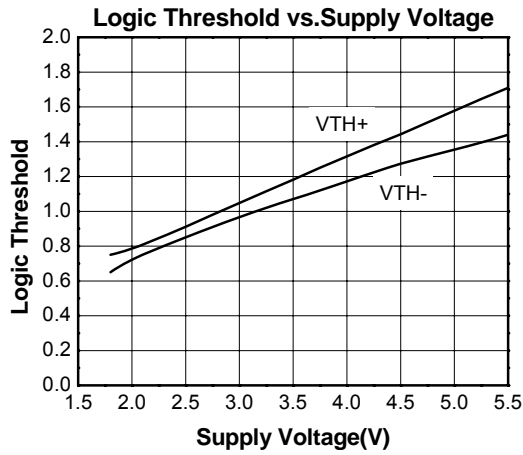

Typical Operating Characteristics

Crosstalk Vs. Frequency

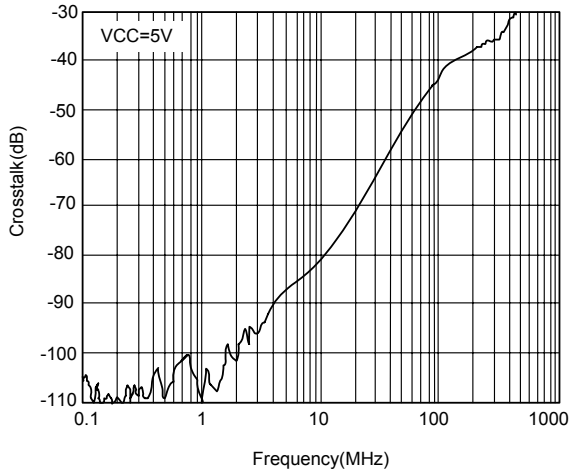

Off-Isolation Vs. Frequency

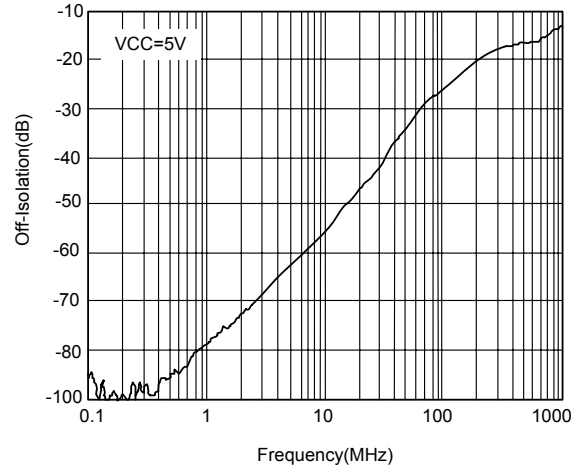

On-Loss Vs. Frequency

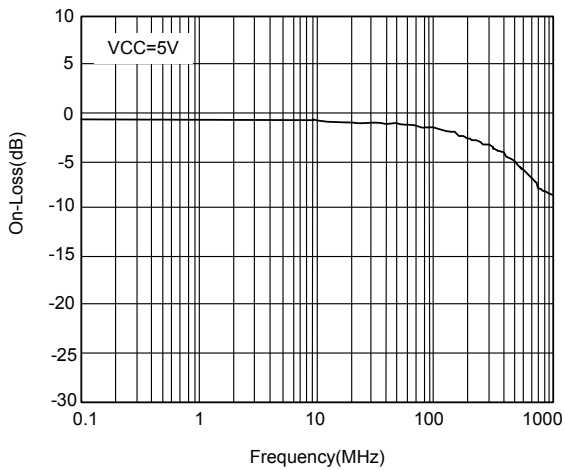

Detailed Description

The UM4258Q high-speed, low-voltage, low on-resistance (R_{ON}), dual SPDT analog switch operates from a single +1.8V to +5.5V supply. The switch features break-before-make switching operation and fast switching speeds ($t_{ON} = 80ns$ (max), $t_{OFF} = 40ns$ (max)).

These switch has low 15pF on-channel capacitance, which allows for 12Mbps switching of the data signals for USB 1.0/1.1 applications. The UM4258Q is designed to switch D_+ and D_- USB signals with a guaranteed skew of less than 2ns (see Figure 4) as measured from 50% of the input signal to 50% of the output signal.

Applications Information

Digital Control Inputs

The UM4258Q logic inputs accept up to +5.5V regardless of supply voltage. For example, with a +3.3V supply, IN_- can be driven low to GND and high to +5.5V allowing for mixing of logic levels in a system. Driving the control logic inputs rail-to-rail minimizes power consumption. For a +3V supply voltage, the logic thresholds are 0.5V (low) and 1.4V (high); for a +5V supply voltage, the logic thresholds are 0.8V (low) and 2.0V (high).

Analog Signal Levels

The on-resistance of the UM4258Q changes very little for analog input signals across the entire supply voltage range (see the Typical Operating Characteristics). The switches are bidirectional, so the NO_- , NC_- , and COM_- pins can be either inputs or outputs.

Power-Supply Sequencing and Over-voltage Protection

Proper power-supply sequencing is recommended for all CMOS devices. Always apply V_+ before applying analog signals, especially if the analog signal is not current-limited.

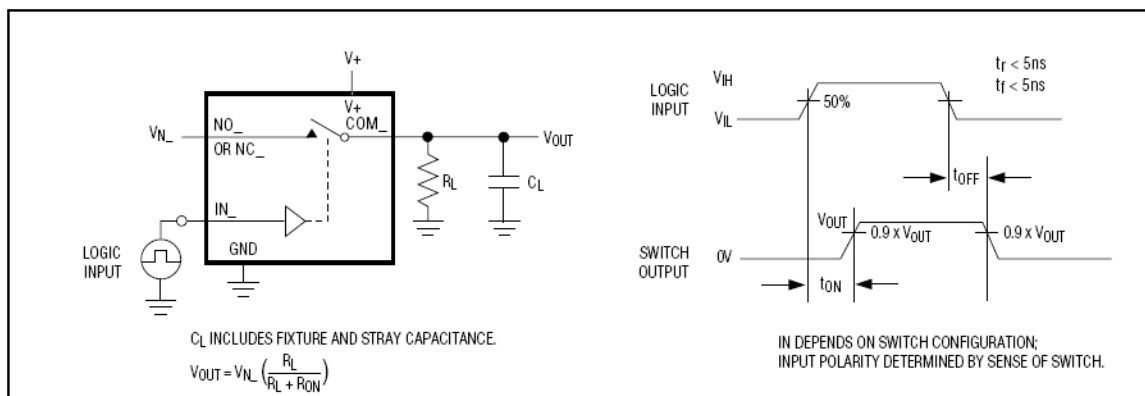

Figure 1. Switching Time

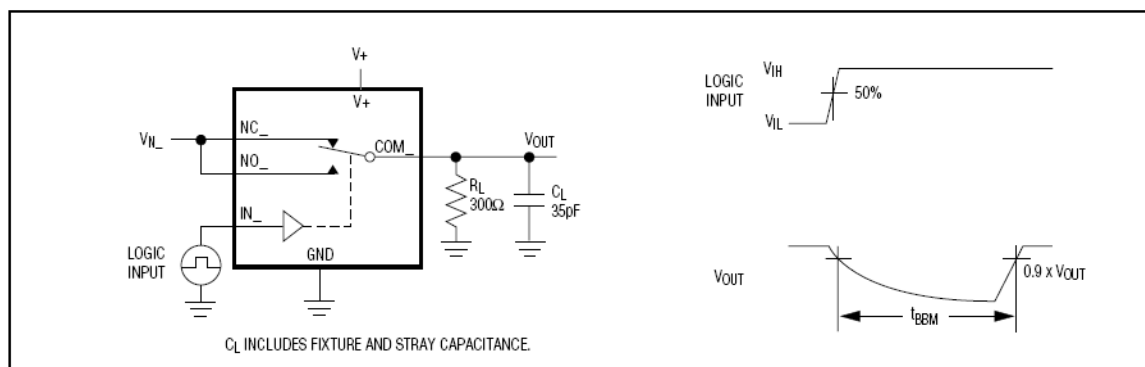

Figure 2. Break-Before-Make Interval

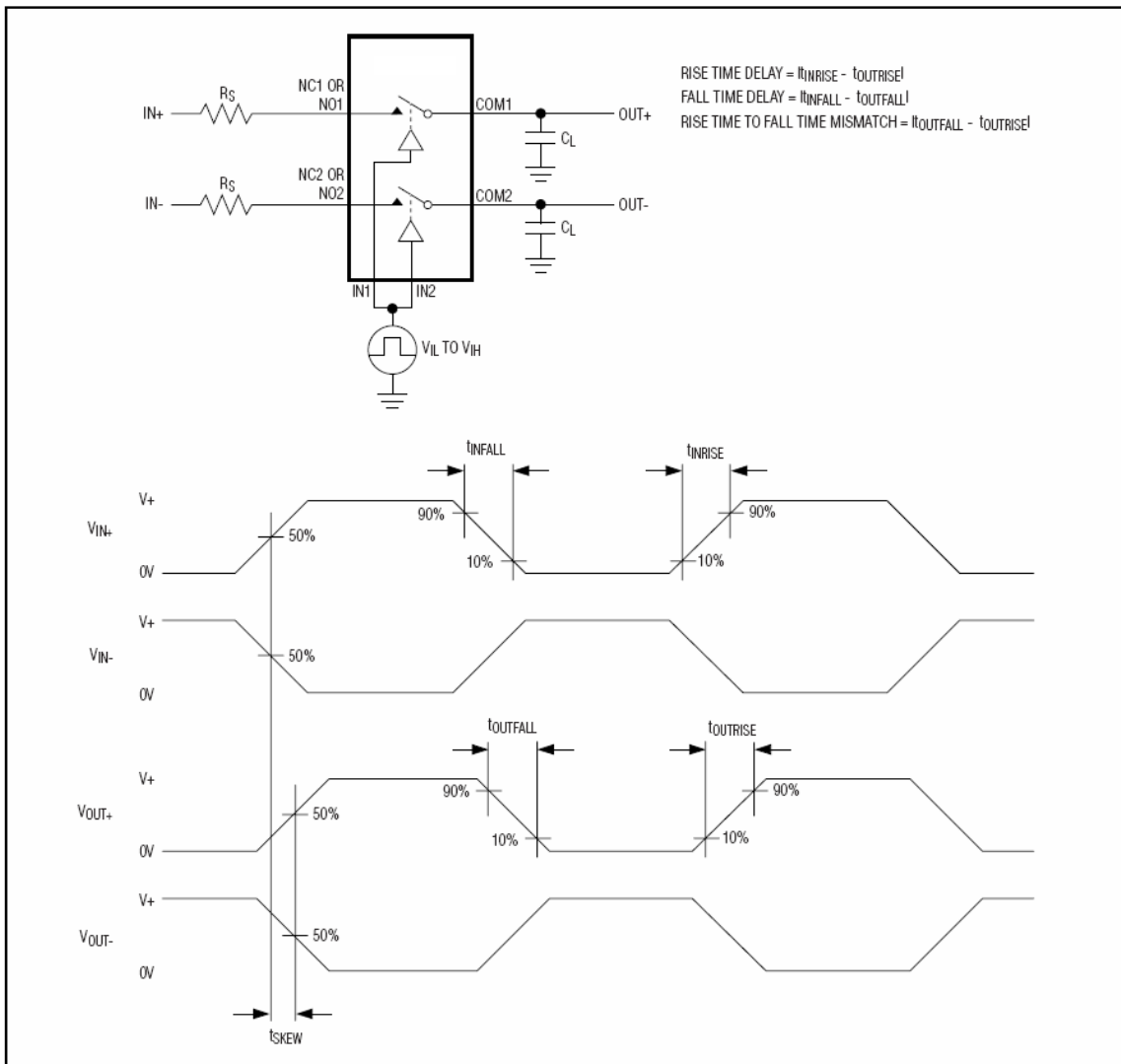

Figure 3. Output Signal Skew

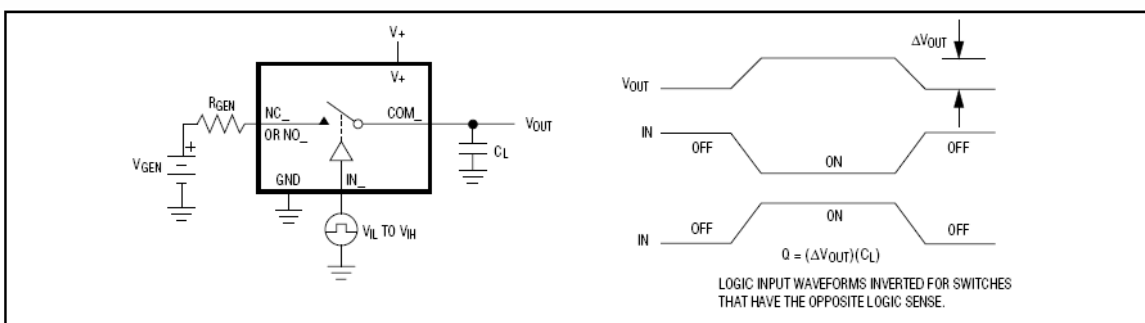

Figure 4. Charge Injection

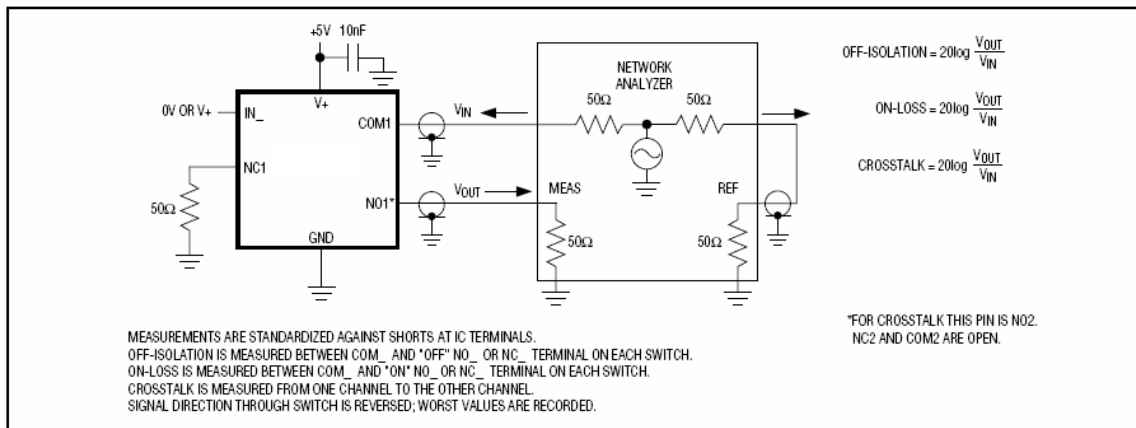

Figure 5. On-Loss, Off-Isolation, and Crosstalk

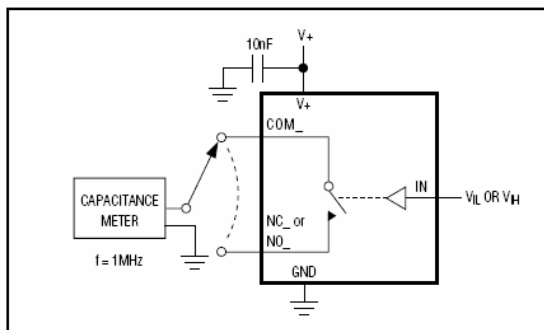
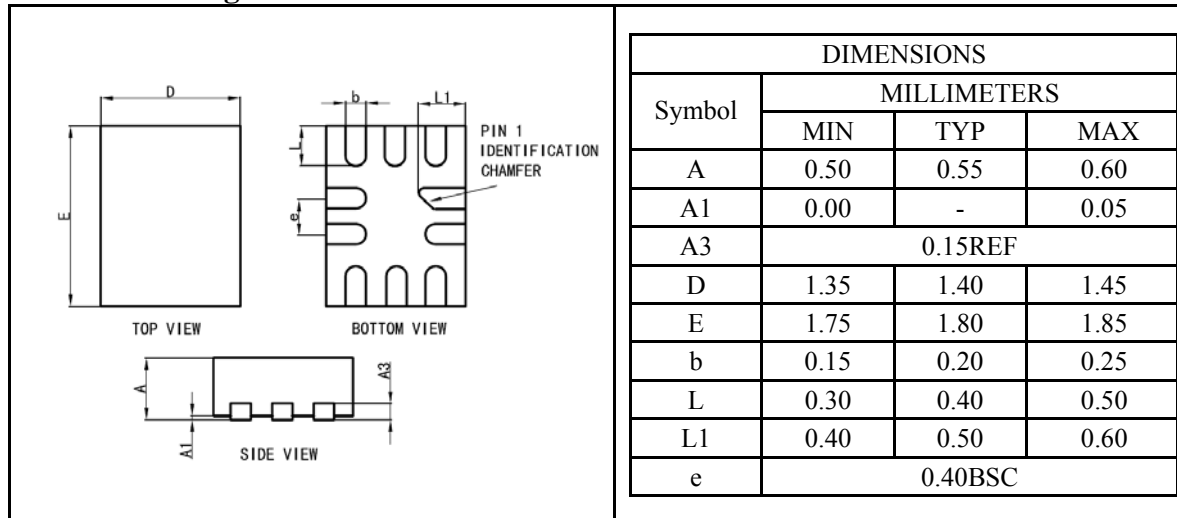

Figure 6. Channel Off/On-Capacitance

Package Information

UM4258Q: QFN10 1.80×1.40

Outline Drawing



Land Pattern

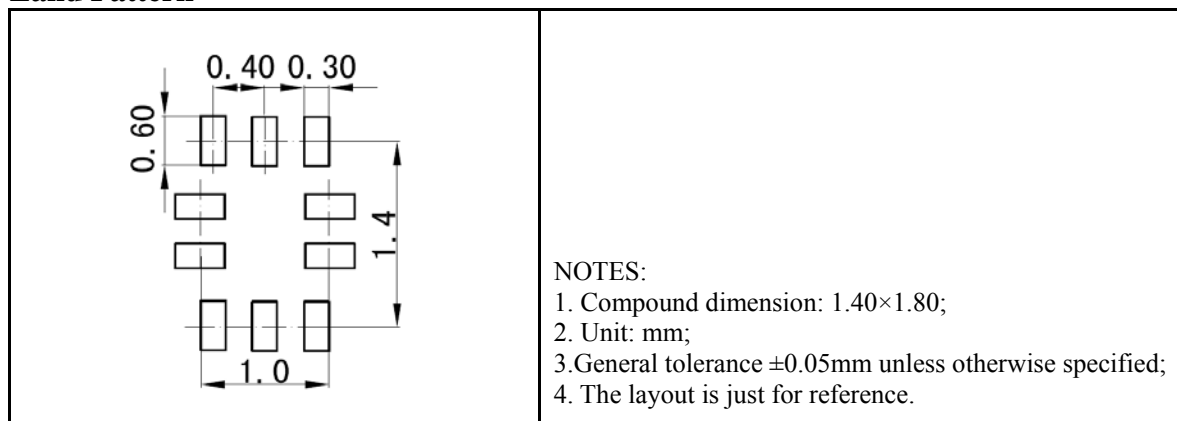

Tape and Reel Orientation

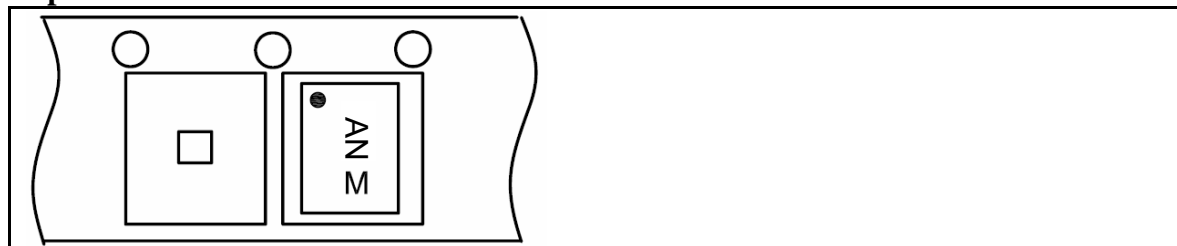

IMPORTANT NOTICE

The information in this document has been carefully reviewed and is believed to be accurate. Nonetheless, this document is subject to change without notice. Union assumes no responsibility for any inaccuracies that may be contained in this document, and makes no commitment to update or to keep current the contained information, or to notify a person or organization of any update. Union reserves the right to make changes, at any time, in order to improve reliability, function or design and to attempt to supply the best product possible.



Union Semiconductor, Inc

Add: 7F, No. 5, Bibo Road, Shanghai 201203

Tel: 021-51097928

Fax: 021-51026018

Website: www.union-ic.com