

Low-Voltage Dual SPDT Analog Switch

UM3258 DFN12 3.0×1.0

General Description

The UM3258 is dual SPDT analog switch fabricated with silicon gate CMOS technology. It achieves very low propagation delay and $R_{DS(ON)}$ resistances while maintaining CMOS low power dissipation. These make it ideal for portable and battery power applications.

The switch conducts signals within power rails equally well in both directions when on, and blocks up to the power supply level when off. Break-before-make is guaranteed.

The select pin has over-voltage protection that allows voltages above V_{CC} , up to 6.5V to be present on the pin without damage or disruption of operation of the part, regardless of the operating voltage.

The UM3258 can maintain low power consumption for rail-to-rail signaling as long as the control signal input is held at a level that is greater than V_{IH} minimum and less than V_{IL} maximum by improving the control circuitry input buffer. so the part can be used in mixed voltage rail environments, especially services the mobile handset applications very well allowing for the direct interface with baseband processor general purpose I/Os, and it is no longer necessary to have the control input equal to V_{CC} to maintain low power consumption

The UM3258 is in a 12-pin, ROHS compliant, DFN12 package. It measures 3.0×1.0mm. The leads are spaced at a pitch of 0.5mm and are finished with lead free Ni-Pd. The small package makes it ideal for use in portable electronics such as cell phones, digital cameras and PDAs.

Applications

- Sample-and-Hold Circuits
- Battery powered Equipment
- Audio and Video Signal Routing
- Communication Circuits

Features

- Lower I_{CC} when the S Input is within the required V_{IH} and V_{IL} bounds
- Low ON-State Resistance (10Ω)
- Control Inputs Are 5V Tolerant
- Low Charge Injection
- Excellent ON-State Resistance Matching
- Low Total Harmonic Distortion (THD)
- 1.65V to 5.5V Single-Supply Operation
- ESD Performance:
Human Body Model > 2KV
Machine Model > 200V
- DFN12 Package
- Pb-Free Package

Pin Configurations

Top View

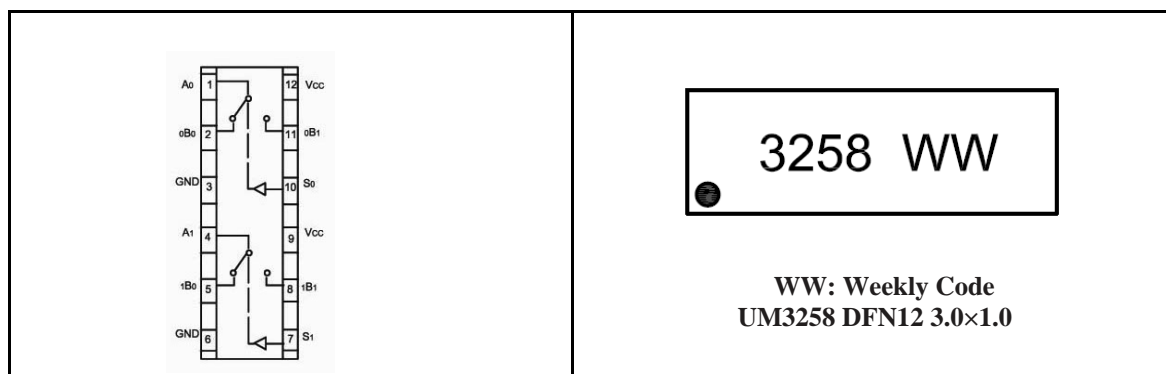

Ordering Information

Part Number	Packaging Type	Marking Code	Shipping Qty
UM3258	DFN12 3.0×1.0	3258	3000pcs/7 Inch Tape & Reel

Function Table

Select Input	Function
L	B0 Connected to A
H	B1 Connected to A

Absolute Maximum Ratings

Symbol	Parameter	Limit	Unit
V_{CC}	Supply Voltage	- 0.5 to + 6.5	V
V_{IS}	DC Switch Input Voltage (Note 1)	- 0.5 to ($V_{CC} + 0.5$)	
V_{IN}	DC IN Voltage (Note 1)	- 0.5 to + 6.5	
I_{IK}	DC Input Diode Current@ $V_{IN} < 0V$	-50	mA
I_{OUT}	DC Output Current	128	
I_{CC}/ I_{GND}	DC V_{CC} or Ground Current	+100	
T_J	Junction Temperature Under Bias	+150	°C
T_{STG}	Storage Temperature	- 65 to +150	
T_L	Junction Lead Temperature (Soldering, 10seconds)	260	
θ_{JA}	Thermal Resistance	350	°C/W
P_D	Power Dissipation @ +85°C	180	mW

1: The input and output negative voltage ratings may be exceeded if the input and output diode current ratings are observed.

Recommended Ratings (Note2)

Symbol	Parameter	Limit	Unit
V_{CC}	Supply Voltage Operating	1.65 to 5.5	V
V_{IS}	Switch Input Voltage	0 to V_{CC}	
V_{IN}	Select Input Voltage	0 to V_{CC}	
V_{OUT}	Output Voltage	0 to V_{CC}	
T_A	Operating Temperature	-55 to +125	°C
t_r, t_f	Input Rise and Fall Time Control Input $V_{CC}=2.3V$ to 3.6V Control Input $V_{CC}=4.5V$ to 5.5V	0 to 10 0 to 5.0	ns/V

2: Select input must be held HIGH or LOW, it must not float.

Electrical Characteristics

Symbol	Parameter	Test Conditions	Vcc(V)	Temp	Limits (-40 to 85 °C)			Unit	
					Min	Typ	Max		
DC Electrical Characteristics									
	Analog Signal Range		V _{cc}	Full	0		V _{cc}	V	
I _{IN}	Input Leakage Current	0 ≤ V _{IN} ≤ 5.5V	0 to 5.5	Room Full		±0.05	±0.1 ±1	μA	
I _{OFF}	OFF State Leakage Current	0 ≤ A, B ≤ V _{cc}	1.65 to 5.5	Room Full		±0.05	±0.1 ±1	μA	
V _{IH}	Input High Voltage		1.65 to 1.95 2.3 to 5.5	Full	0.75V _{cc} 0.7V _{cc}			V	
V _{IL}	Input Low Voltage		1.65 to 1.95 2.3 to 5.5	Full			0.25V _{cc} 0.3V _{cc}	V	
I _{CC}	Quiescent Supply Current	V _{IN} = V _{cc} or GND I _O = 0	5.5	Room Full			1.0 10	μA	
R _{ON}	On-Resistance (Note3)	V _{IN} = 0V, I _O = 30mA	4.5	Full			3.0	6.0	
		V _{IN} = 2.4V, I _O = -30mA					5.0	8.0	
		V _{IN} = 4.5V, I _O = -30mA					7.0	13	
		V _{IN} = 0V, I _O = 24mA	3.0	Full				4.0	8.0
		V _{IN} = 3V, I _O = -24mA						10	19
V _{IN} = 0V, I _O = 8mA	2.3	Full				5.0	9.0		
V _{IN} = 2.3V, I _O = -8mA						13	24		
V _{IN} = 0V, I _O = 4mA	1.65	Full				6.5	12		
V _{IN} = 1.65V, I _O = -4mA						17	39		
R _{RANGE}	On Resistance Over Signal Range (Note3,7)	I _A = -30mA, 0 ≤ V _{Bn} ≤ V _{cc}	4.5	Full			25		
		I _A = -24mA, 0 ≤ V _{Bn} ≤ V _{cc}	3.0	Full			50		
		I _A = -8mA, 0 ≤ V _{Bn} ≤ V _{cc}	2.3	Full			100		
		I _A = -4mA, 0 ≤ V _{Bn} ≤ V _{cc}	1.65	Full			300		
ΔR _{ON}	On Resistance Match Between Channels (Note3,4,5)	I _A = -30mA, V _{Bn} = 3.15V	4.5	Room		0.15			
		I _A = -24mA, V _{Bn} = 2.1V	3.0	Room		0.2			
		I _A = -8mA, V _{Bn} = 1.6V	2.3	Room		0.5			
		I _A = -4mA, V _{Bn} = 1.15V	1.65	Room		0.5			
R _{FLAT}	On Resistance Flatness (Note3,4,6)	I _A = -30mA, 0 ≤ V _{Bn} ≤ V _{cc}	5.0	Room		5.0			
		I _A = -24mA, 0 ≤ V _{Bn} ≤ V _{cc}	3.3	Room		10			
		I _A = -8mA, 0 ≤ V _{Bn} ≤ V _{cc}	2.5	Room		24			
		I _A = -4mA, 0 ≤ V _{Bn} ≤ V _{cc}	1.8	Room		110			

3: Measured by the voltage drop between A and B pins at the indicated current through the switch. On Resistance is determined by the lower of the voltages on the two (A or B Ports).

4: Parameter is characterized but not tested in production.

5: ΔR_{ON} = | R_{ON(A00Bn)} - R_{ON(A11Bn)} | measured at identical V_{cc}, temperature and voltage levels.

6: Flatness is defined as the difference between the maximum and minimum value of On Resistance over the specified range of conditions.

7: Guaranteed by Design.

Electrical Characteristics (Continued)

Symbol	Parameter	Test Conditions	Vcc(V)	Temp	Limits (-40 to 85 °C)			Unit
					Min	Typ	Max	
AC Electrical Characteristics								
t_{PHL} t_{PLH}	Propagation Delay Bus to Bus (Note 9)	$V_i = OPEN$	1.65 to 1.95 2.3 to 2.7 3.0 to 3.6 4.5 to 5.5	Room		1.2 0.8 0.3		ns
t_{PZL} t_{PZH}	Output Enable Time Turn On Time (A to Bn)	$V_i = 2 \times V_{CC}$ for t_{PZL} $V_i = 0 V$ for t_{PZH}	1.65 to 1.95 2.3 to 2.7 3.0 to 3.6 4.5 to 5.5	Full	7.0 3.5 2.5 1.7		32 14 7.6 5.7	ns
t_{PLZ} t_{PHZ}	Output Disable Time Turn Off Time (A Port to B Port)	$V_i = 2 \times V_{CC}$ for t_{PLZ} $V_i = 0 V$ for t_{PHZ}	1.65 to 1.95 2.3 to 2.7 3.0 to 3.6 4.5 to 5.5	Full	3.0 2.0 1.5 0.8		28 15 11 8	ns
t_{BBM}	Break Before Make Time (Note 8)	$R_L = 50\Omega$, $C_L = 35pF$	1.65 to 1.95 2.3 to 2.7 3.0 to 3.6 4.5 to 5.5	Full	0.5 0.5 0.5 0.5			ns
Q_{INJ}	Charge Injection (Note 8)	$C_L = 0.1 nF$, $V_{GEN} = 0 V$, $R_{GEN} = 0\Omega$	5.0 3.3	Room		7.0 3.0		pC
O_{IRR}	Off Isolation (Note 10)	$R_L = 50\Omega$, $f = 10 MHz$	1.65 to 5.5	Room		-55		dB
Xtalk	Crosstalk	$R_L = 50\Omega$, $f = 10 MHz$	1.65 to 5.5	Room		-54		dB
BW	-3 dB Bandwidth	$R_L = 50\Omega$	2.5 to 5.5	Room		300		MHz
THD	Total Harmonic Distortion (Note 8)	$R_L = 600\Omega$ $0.5V_{P-P}$ $f = 600Hz$ to $20kHz$	2.5 5.0	Room		0.014 0.004		%
Capacitance								
C_{IN}	IN Pin Input Capacitance (Note 11)	$V_{CC} = 0V$				2.3		pF
C_{IO-B}	B Port Off Capacitance (Note 11)	$V_{CC} = 5.0V$				6.5		pF
C_{IOA-ON}	A Port Capacitance when Switch is Enabled (Note 11)	$V_{CC} = 5.0V$				18.5		pF

8: Guaranteed by Design.

9: This parameter is guaranteed by design but not tested. The bus switch contributes no propagation delay other than the RC delay of the On Resistance of the switch and the 35 pF load capacitance, when driven by an ideal voltage source (zero output impedance).

10: Off Isolation = $20 \log_{10} [V_A/V_{Bn}]$.

11: $T_A = +25$, $f = 1 MHz$, Capacitance is characterized but not tested in production.

Test Circuits/Timing Diagrams

NOTE: Input driven by 50 Ω source terminated in 50 Ω
 NOTE: C_L includes load and stray capacitance
 NOTE: Input PRR = 1.0 MHz; $t_{WY} = 500$ ns

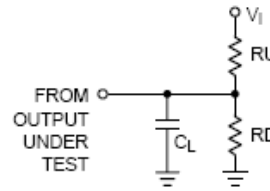

Figure 1 . AC Test Circuit

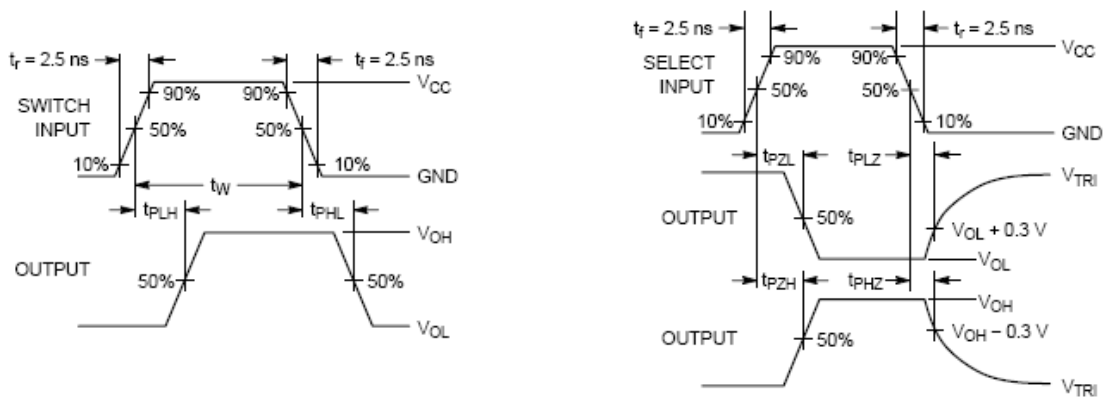
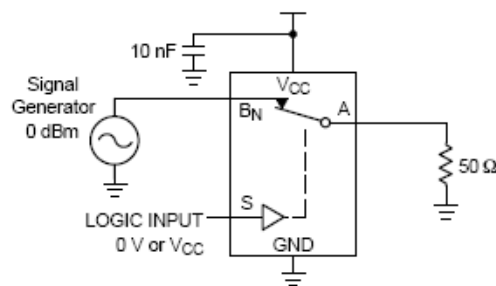
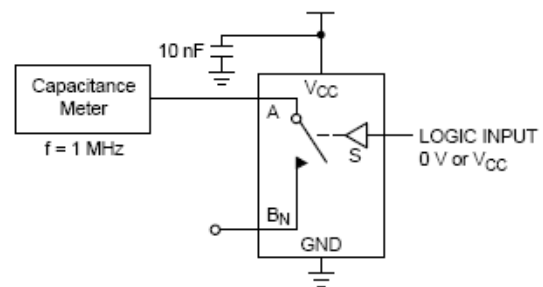
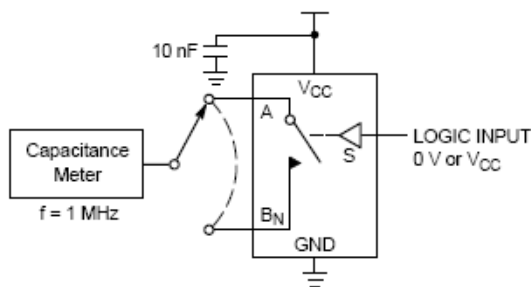
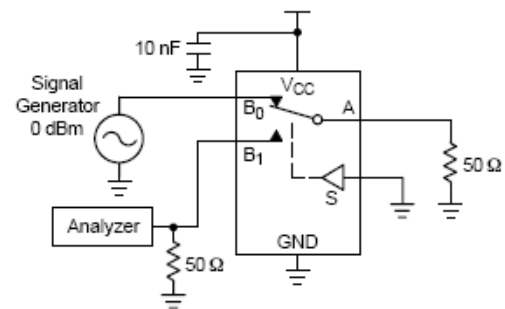
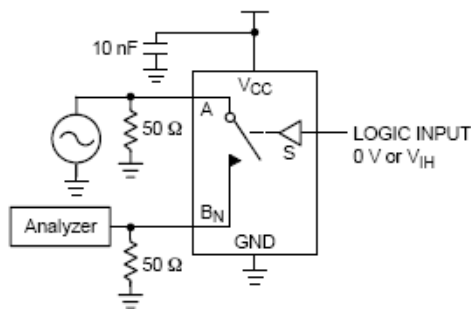
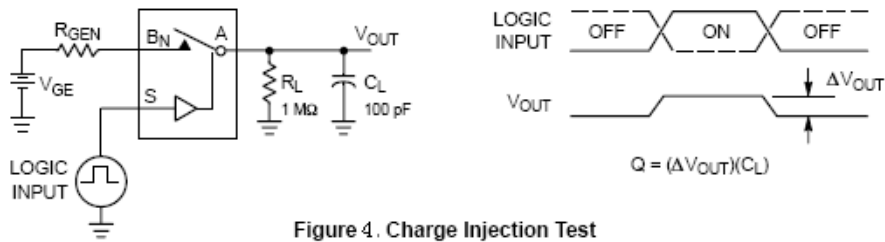

Figure 2 . AC Waveforms

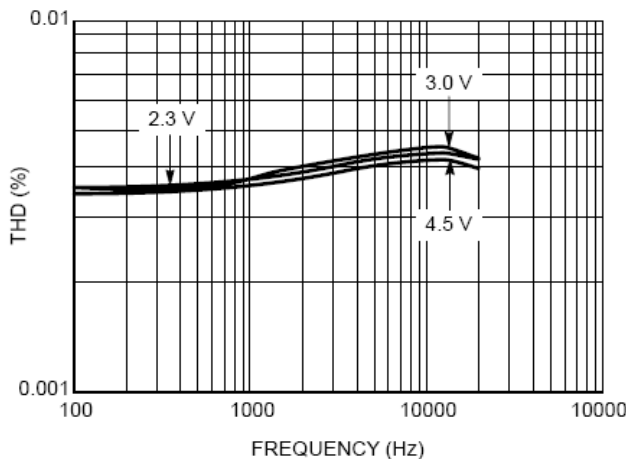

Figure 3 . Break Before Make Interval Timing



Typical Operating Characteristics

Total Harmonic Distortion vs Frequency



R_{ON} vs V_{IN} vs Temperature @ V_{CC}=3.0V

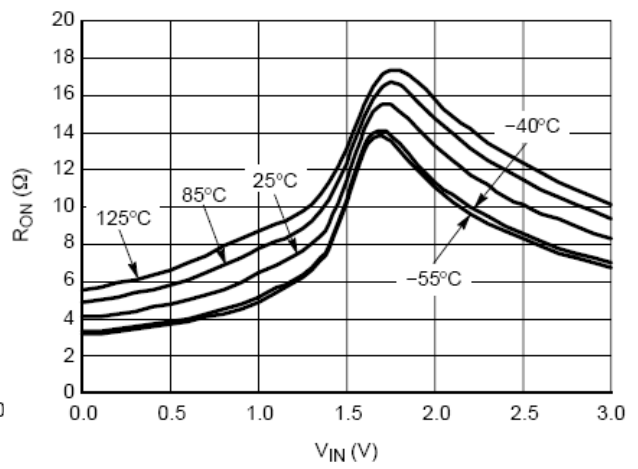

R_{ON} vs V_{IN} vs Temperature @ V_{CC}=4.5V

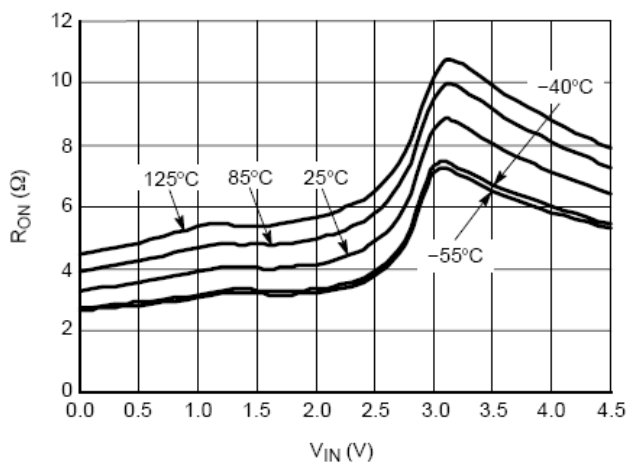

On-Resistance vs Input Voltage

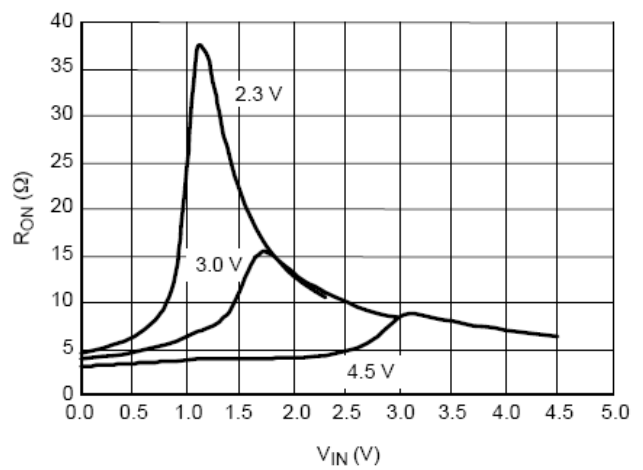

Typical Operating Characteristics (Continued)

Bandwidth vs Frequency

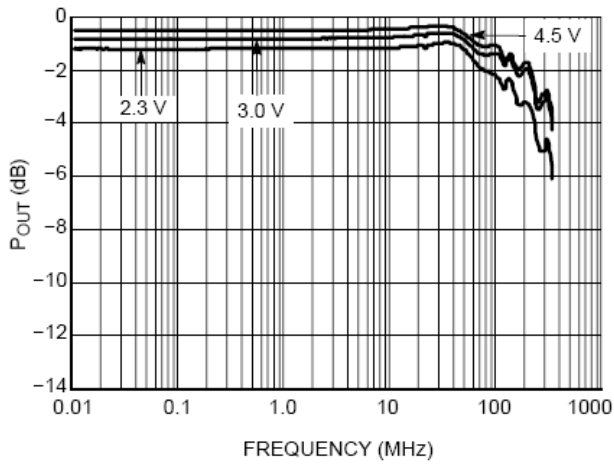

Off-Isolation vs Frequency

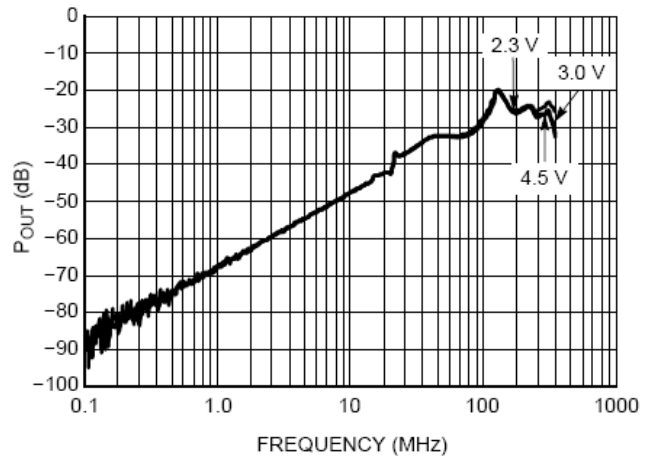

Phase Angle vs Frequency

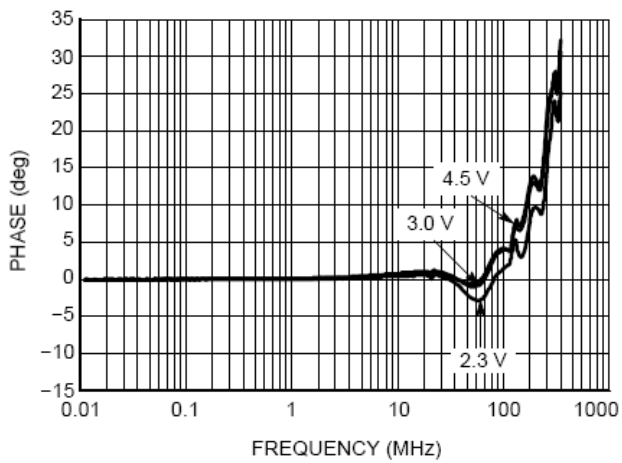

Package Information

UM3258 DFN12 3.0×1.0

Outline Drawing

Top View: Shows overall dimensions D and L. A marking for Pin 1 is shown at the top-left corner.

Bottom View: Shows the layout of 12 pins with dimensions b, e, and D1. Pin 1 identification is marked at the bottom-right.

Side View: Shows the package height A, and pin heights A1 and A2.

DIMENSIONS			
Symbol	MILLIMETERS		
	Min	Typ	Max
A	0.700	0.750	0.800
A1			0.050
A2	0.203 Ref		
b	0.150	0.200	0.250
e	0.500 Bsc		
D	2.950	3.000	3.050
E	0.950	1.000	1.050
D1	2.500 Ref		
L	0.300	0.350	0.400

Land Pattern

Land pattern diagram showing a 2x6 grid of rectangular pads. Dimensions 0.53, 0.30, 0.50, and 0.25 are indicated.

NOTES:

1. Compound dimension: 3.0×1.0;
2. Unit: mm;
3. General tolerance ±0.05mm unless otherwise specified;
4. The layout is just for reference.

Tape and Reel Orientation

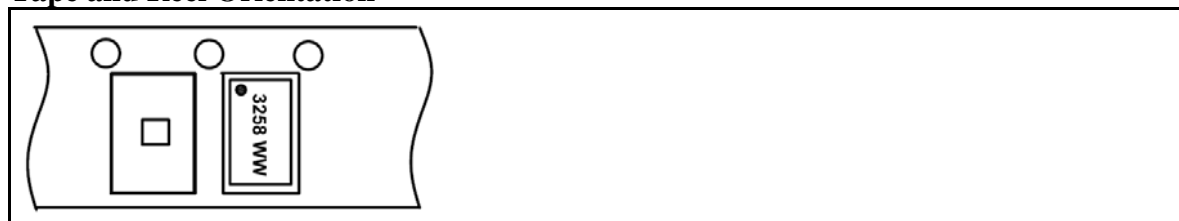

IMPORTANT NOTICE

The information in this document has been carefully reviewed and is believed to be accurate. Nonetheless, this document is subject to change without notice. Union assumes no responsibility for any inaccuracies that may be contained in this document, and makes no commitment to update or to keep current the contained information, or to notify a person or organization of any update. Union reserves the right to make changes, at any time, in order to improve reliability, function or design and to attempt to supply the best product possible.



Union Semiconductor, Inc

Add: 7F, No. 5, Bibo Road, Shanghai 201203

Tel: 021-51097928

Fax: 021-51026018

Website: www.union-ic.com