

0.8Ω Low-Voltage SPDT Analog Switch

UM4157 SOT363

General Description

The UM4157 is a low on resistance, low-power, Single Pole Double Throw (SPDT) analog switch. This product has been designed for switching audio signals in applications such as cell phones and portable media players. The ultra-low 0.8Ω impedance, sub μA current consumption, and 1.65V to 4.3V operating voltage range make this product ideal for battery-powered applications. The UM4157 also features bidirectional operation and break-before-make functionality. This device is fully specified for operation at 1.8V, 2.5V, and 3.3V.

Applications

- Cellular Phone
- PDA
- Portable Media Player

Features

- Typical 0.8Ω On Resistance (R_{ON}) for 2.7V Supply
- 0.23Ω typical R_{ON} Flatness for 2.7V Supply
- Broad V_{CC} Operating Range: 1.65V to 4.3V
- Low THD (0.02% Typical for 32Ω Load)
- Control Logic is 1.8V CMOS Logic Compatible

Pin Configurations

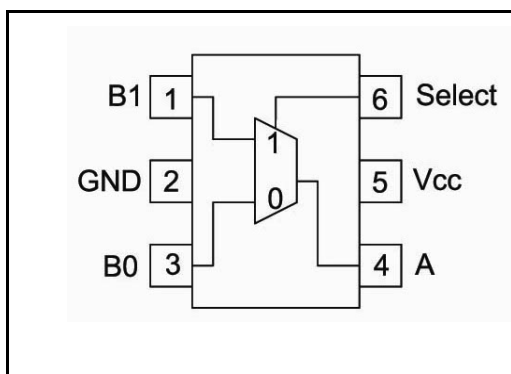

Top View

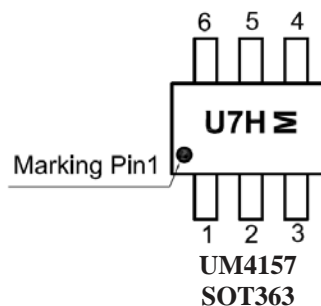

Ordering Information

Part Number	Packaging Type	Marking Code	Shipping Qty
UM4157	SOT363	U7H	3000pcs/7 Inch Tape & Reel

Function Table

Select Input	Function
L	B0 Connected to A
H	B1 Connected to A

Absolute Maximum Ratings

Symbol	Parameter	Limit	Unit
V_{CC}	Supply Voltage	- 0.5 to + 5.5	V
V_S	DC Switch Voltage (Note 1)	- 0.5 to ($V_{CC} + 0.3$)	
V_{IN}	DC IN Voltage (Note 1)	- 0.5 to + V_{CC}	
I_{IK}	DC Input Diode Current	-50	mA
I_{SW}	DC Switch Current	100	
I_{SWPEAK}	Peak Switch Current (Pulsed at 1ms duration, < 10% Duty Cycle)	150	
T_J	Junction Temperature Under Bias	+150	°C
T_{STG}	Storage Temperature Range	- 65 to +150	
T_L	Junction Lead Temperature (Soldering, 10seconds)	+260	
ESD	Human Body Model	2000	V
P_D	SOT363 Package	180	mW

Note 1: The input and output negative voltage ratings may be exceeded if the input and output diode current ratings are observed.

Recommended Ratings

Symbol	Parameter	Limit	Unit
V_{CC}	Supply Voltage Operating	1.65 to 4.3	V
V_{IN}	Control Input Voltage (Note 2)	0 to V_{CC}	
V_{IN}	Switch Input Voltage	0 to V_{CC}	
T_A	Operating Temperature	-45 to +85	°C

Note 2: Unused inputs must be held HIGH or LOW, it must not float.

Electrical Characteristics

Symbol	Parameter	Test Conditions	Vcc(V)	Temp	Limits (-40 to 85 °C)			Unit	
					Min	Typ	Max		
DC Electrical Characteristics									
I_{IN}	Control Leakage Current	$0 \leq V_{IN} \leq V_{CC}$	1.65 to 4.3	Full	-0.5		+0.5	μA	
$I_{OFF(NO/N C)}$	OFF State Leakage Current	A=0.3V, V_{CC} -0.3V, B_0 or B_1 =0.3V, V_{CC} -0.3V or Floating	1.95 to 4.3	Room Full	-10 -50		+10 +50	nA	
$I_{ON(A)}$	On State Leakage Current	A=0.3V, V_{CC} -0.3V, B_0 or B_1 =0.3V, V_{CC} -0.3V or Floating	1.95 to 4.3	Room Full	-20 -100		+20 +100	nA	
V_{IH}	Input High Voltage		3.6 to 4.3	Full	1.4			V	
			2.7 to 3.6		1.3				
			2.3 to 2.7		1.1				
			1.65 to 1.95		0.9				
V_{IL}	Input Low Voltage		3.6 to 4.3	Full			0.7	V	
			2.7 to 3.6				0.5		
			2.3 to 2.7				0.4		
			1.65 to 1.95				0.4		
I_{CC}	Quiescent Supply Current	$V_{IN} = V_{CC}$ or GND $I_O = 0$	4.3	Full	-3		3	μA	
R_{ON}	On-Resistance (Note3)		$I_{OUT} = 100mA$, B_0 or $B_1 = 0V, 0.7V, 3.6V, 4.3V$	4.3	Full		0.6	1.0	Ω
			$I_{OUT} = 100mA$, B_0 or $B_1 = 0V, 0.7V, 2.0V, 2.7V$	2.7	Full		0.8	1.2	
			$I_{OUT} = 100mA$, B_0 or $B_1 = 0V, 0.7V, 2.0V, 2.3V$	2.3	Full		0.9	1.3	
			$I_{OUT} = 100mA$, B_0 or $B_1 = 0.7V$	1.65	Room Full		1.5	2.5 3.0	
ΔR_{ON}	On Resistance Match Between Channels (Note4)	$I_{OUT} = 100mA$, B_0 or $B_1 = 0.7V$	4.3	Full		0.04	0.75	Ω	
			2.7	Full		0.06	0.13		
			2.3	Full		0.12	0.20		
			1.65	Full		1.0			
R_{FLAT}	On Resistance Flatness (Note5)	$I_{OUT} = 100mA$, B_0 or $B_1 = 0V$ to V_{CC}	4.3	Full		0.18	0.5	Ω	
			2.7	Full		0.23	0.5		
			2.3	Full		0.28	0.6		
			1.65	Room		0.3			

Note 3: Measured by the voltage drop between A and B pins at the indicated current through the switch. On Resistance is determined by the lower of the voltages on the two (A or B Ports).

Note 4: $\Delta R_{ON} = |R_{ON(B0)} - R_{ON(B1)}|$ measured at identical V_{CC} , temperature and voltage levels.

Note 5: Flatness is defined as the difference between the maximum and minimum value of On Resistance over the specified range of input voltage.

Electrical Characteristics (Continued)

Symbol	Parameter	Test Conditions	Vcc(V)	Temp	Limits (-40 to 85 °C)			Unit
					Min	Typ	Max	
AC Electrical Characteristics								
t _{ON}	Turn-On Time	B ₀ or B ₁ =1.5V, R _L =50Ω, C _L =35pF	3.6 to 4.3	Room Full			55 60	ns
			2.7 to 3.6	Room Full			60 65	
			2.3 to 2.7	Room Full			65 70	
			1.65 to 1.95	Full		70	90	
t _{OFF}	Turn-Off Time	B ₀ or B ₁ =1.5V, R _L =50Ω, C _L =35pF	3.6 to 4.3	Room Full			30 35	ns
			2.7 to 3.6	Room Full			35 40	
			2.3 to 2.7	Room Full			40 45	
			1.65 to 1.95	Full		40	55	
t _{BBM}	Break Before Make Time	B ₀ or B ₁ =1.5V, R _L =50Ω, C _L =35pF	1.65 to 4.3	Full	5			ns
Q _{INI}	Charge Injection	C _L = 1.0 nF, V _{GEN} = 0 V R _{GEN} = 0Ω	3.6 to 4.3	Room		6		pC
			2.7 to 3.6	Room		6		
			2.3 to 2.7	Room		6		
			1.65 to 1.95	Room				
O _{IRR}	Off Isolation	f = 100 kHz, R _L =50Ω, C _L = 5pF(Stray),	1.65 to 4.3	Room		-75		dB
Xtalk	Crosstalk	f = 100 kHz, R _L =50Ω, C _L = 5pF(Stray),	3.6 to 4.3	Room		-75		dB
			2.7 to 3.6	Room		-75		
			2.3 to 2.7	Room		-75		
			1.65 to 1.95	Room		-70		
BW	-3 dB Bandwidth	R _L =50Ω	1.65 to 4.3	Room		70		MHz
THD	Total Harmonic Distortion		3.6 to 4.3					%
			2.7 to 3.6	Room		0.02		
			2.3 to 2.7	Room		0.036		
			1.65 to 1.95	Room		0.01		
Capacitance								
C _{IN}	Control Pin Input Capacitance	f=1MHz	0.0	Room		1.5		pF
C _{IO-B}	B Port Off Capacitance	f=1MHz	4.5	Room		21.0		pF
C _{IOA-ON}	A Port Capacitance when Switch is Enabled	f=1MHz	4.5	Room		90.0		pF

Typical Characteristics

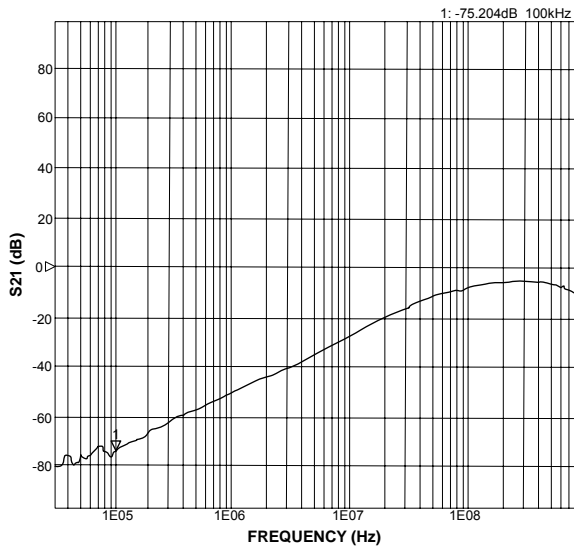

Figure1. Off-Isolation at VCC=3.3V

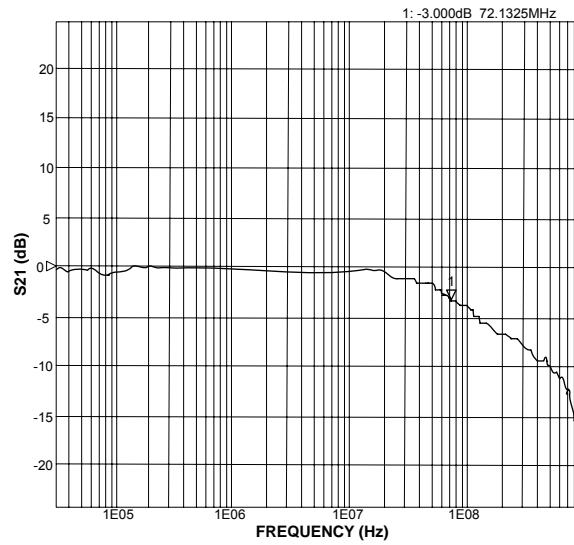

Figure2. Bandwidth at VCC=3.3V

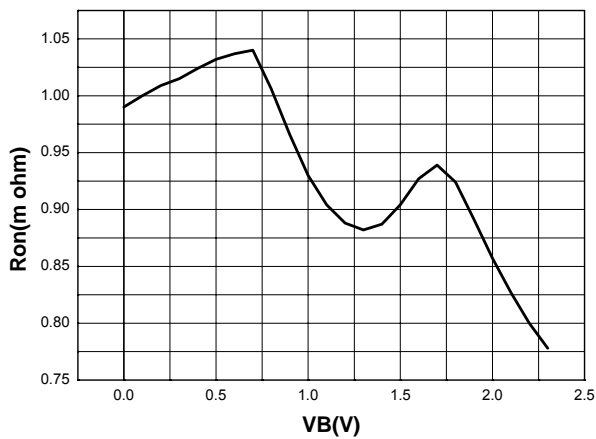

Figure3. Switch On Resistance, Ion=100mA, Vcc=2.3V, B1

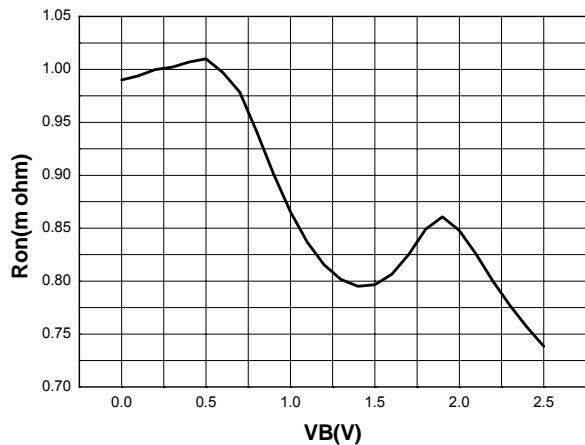

Figure4. Switch On Resistance, Ion=100mA, Vcc=2.5V, B1

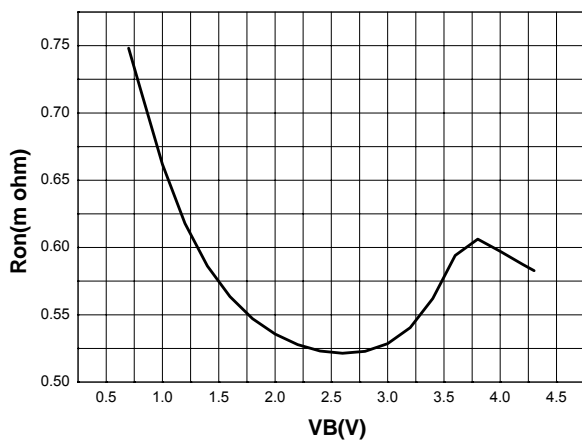
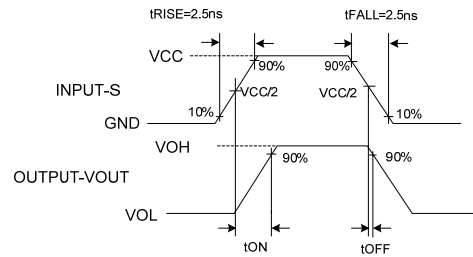
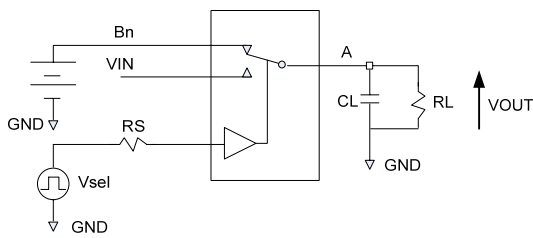

Figure5. Switch On Resistance, Ion=100mA, Vcc=4.3V, B1

Test Circuits/Timing Diagrams



Notes:

6. RL, RS, and CL are functions of the application environment. (see AC Electrical table for specific values)

7. CL includes test fixture and stray capacitance.

Figure 6. Turn-Off Timing

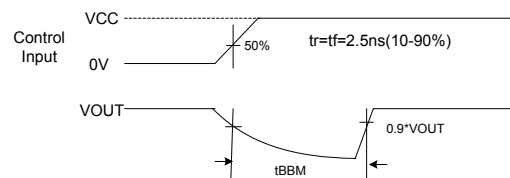
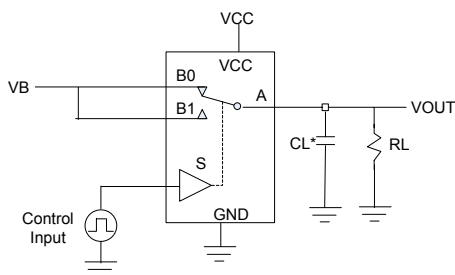

CL* includes fixture and stray capacitance

Figure 7. Break-Before-Make Timing

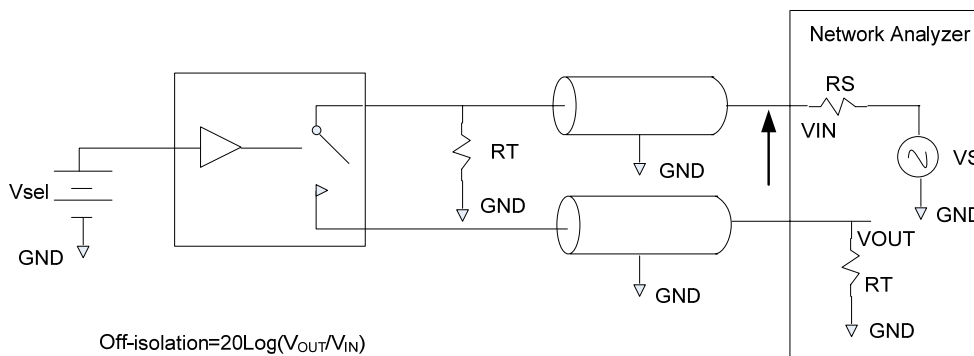

Figure 8. Off-Isolation

Test Circuits/Timing Diagrams (Continued)

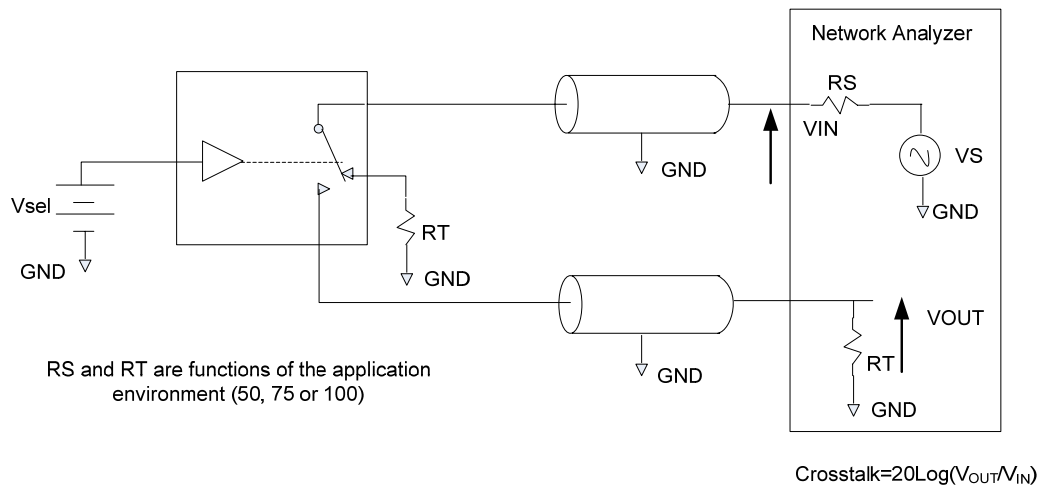

Figure 9. Non-Adjacent Channel-to-Channel Crosstalk

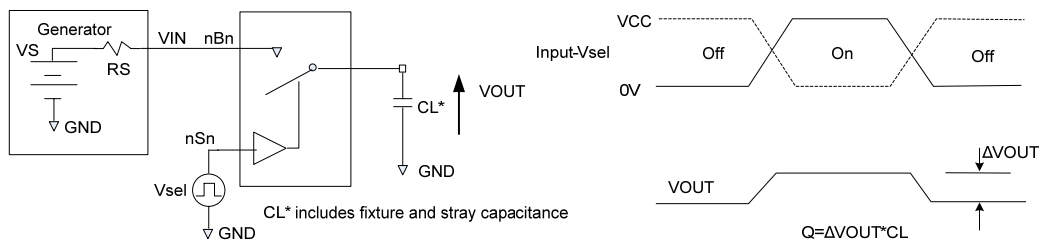

Figure 10. Charge Injection Test

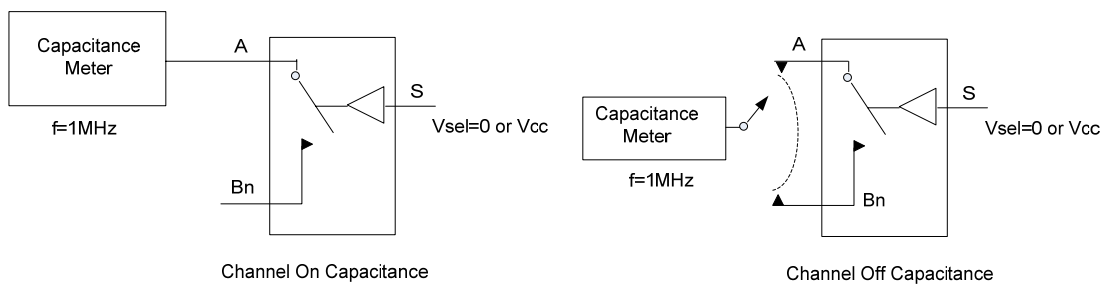

Figure 11. On/Off Capacitance Measurement Setup

Test Circuits/Timing Diagrams (Continued)

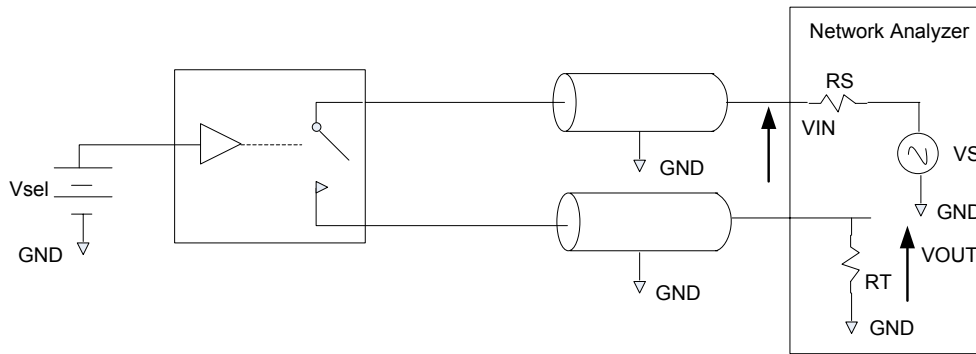

Figure 12. Bandwidth

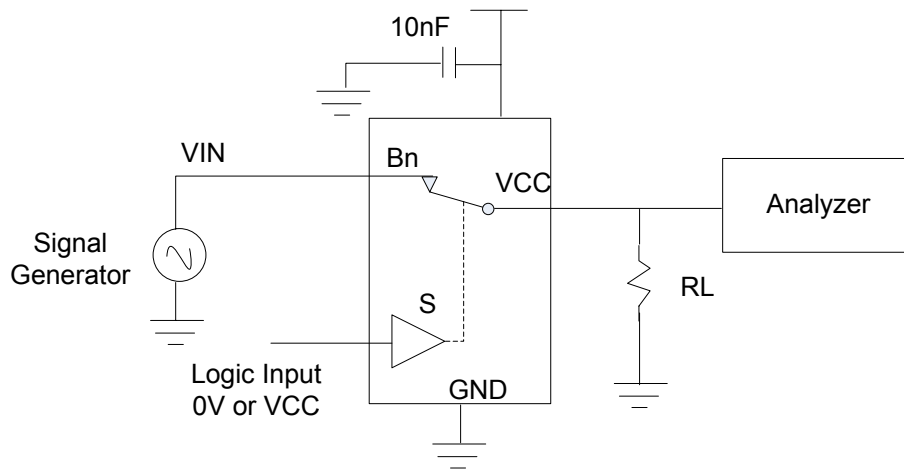
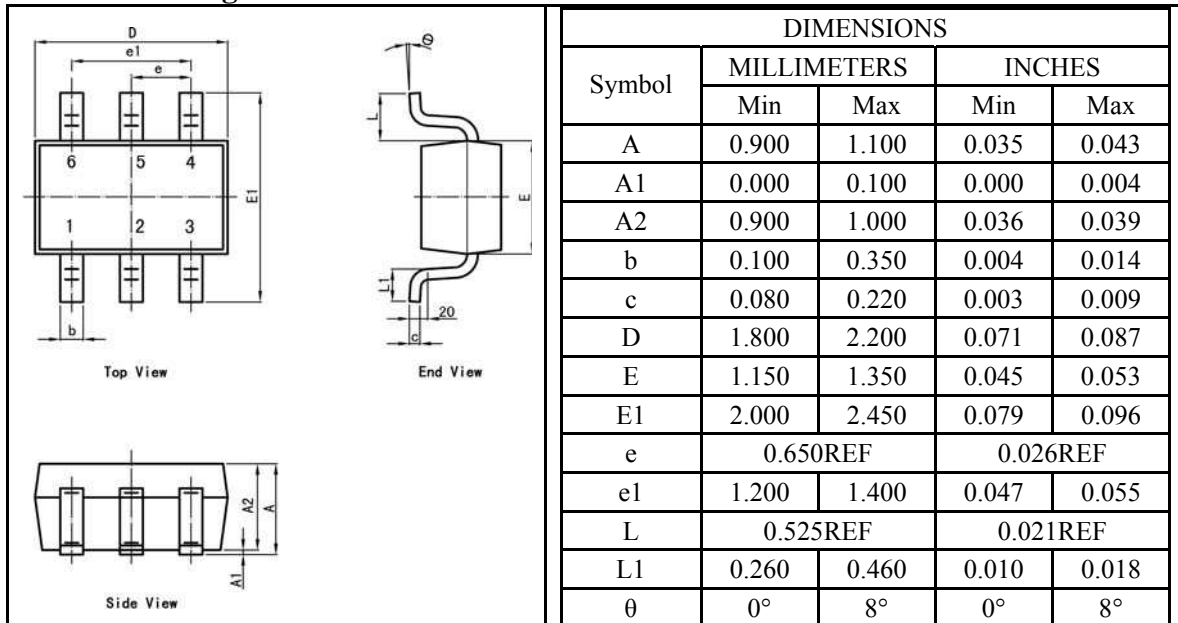

Figure 13. Harmonic Distortion

Package Information

UM4157 SOT363

Outline Drawing



Land Pattern

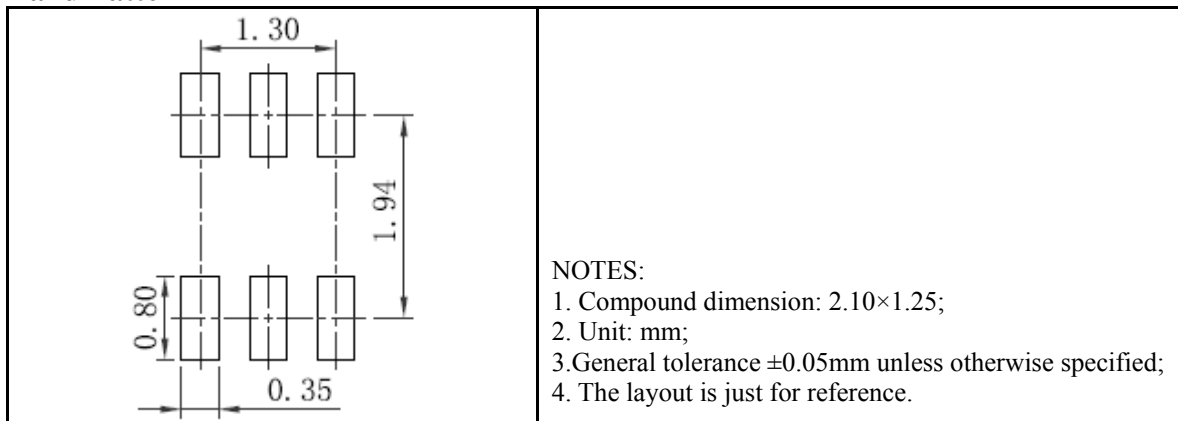

Tape and Reel Orientation



IMPORTANT NOTICE

The information in this document has been carefully reviewed and is believed to be accurate. Nonetheless, this document is subject to change without notice. Union assumes no responsibility for any inaccuracies that may be contained in this document, and makes no commitment to update or to keep current the contained information, or to notify a person or organization of any update. Union reserves the right to make changes, at any time, in order to improve reliability, function or design and to attempt to supply the best product possible.



Union Semiconductor, Inc

Add: 7F, No. 5, Bibo Road, Shanghai 201203

Tel: 021-51097928

Fax: 021-51026018

Website: www.union-ic.com