

Single Line ESD Protection Diode Array

UM5059 DFN2 1.0×0.6

General Description

The UM5059 ESD protection diode is designed to replace multilayer varistors (MLVs) in portable applications such as cell phones, notebook computers, and PDA's. They feature large cross-sectional area junctions for conducting high transient currents, offer desirable electrical characteristics for board level protection, such as fast response time, lower operating voltage, lower clamping voltage and no device degradation when compared to MLVs. The UM5059 ESD protection diode protects sensitive semiconductor components from damage or upset due to electrostatic discharge (ESD) and other voltage induced transient events. The UM5059 is available in DFN2 1.0×0.6 (compatible with SOD923 & SOD882) package with working voltages of 5 volt. It gives designer the flexibility to protect one unidirectional line in applications where arrays are not practical. Additionally, it may be "sprinkled" around the board in applications where board space is at a premium. It may be used to meet the ESD immunity requirements of IEC 61000-4-2, ±30kV air, ±30kV contact discharge.

Applications

- Cell Phone Handsets and Accessories
- Personal Digital Assistants (PDA's)
- Notebooks, Desktops and Servers
- Portable Instrumentation
- Cordless Phones
- Digital Cameras
- Peripherals
- MP3 Players

Features

- Transient protection for data lines to IEC 61000-4-2 (ESD) ±30kV (air), ±30kV (contact)
- Small package for use in portable electronics
- Suitable replacement for MLV's in ESD protection applications
- Protect one I/O or power line
- Low clamping voltage
- Stand off voltage: 5V
- Low leakage current
- Solid-state silicon-avalanche technology
- Small Body Outline Dimensions: 1.0mm×0.6mm

Pin Configurations

Top View

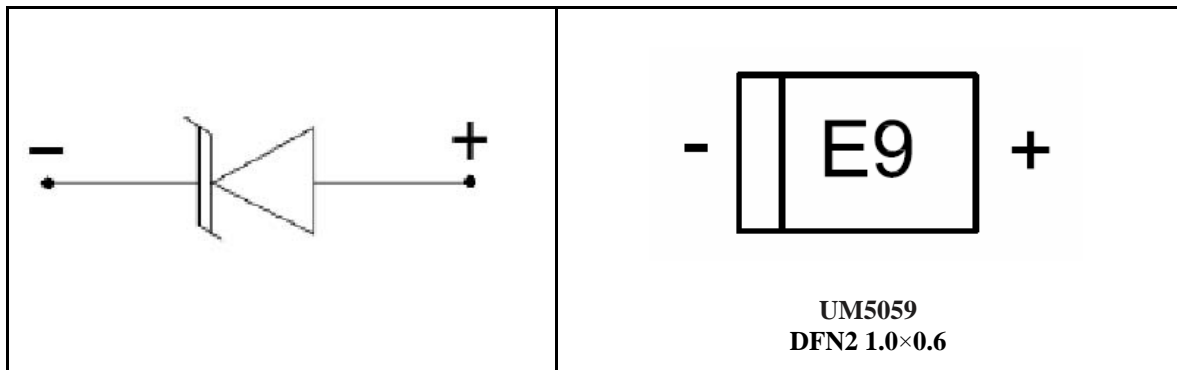

Ordering Information

Part Number	Working Voltage	Packaging Type	Channel	Marking Code	Shipping Qty
UM5059	5.0V	DFN2 1.0×0.6mm ²	1	E9	5000pcs/7 Inch Tape & Reel

Absolute Maximum Ratings

RATING	SYMBOL	VALUE	UNITS
Peak Pulse Power ($t_p = 8/20\mu s$)	P_{PK}	140	Watts
Maximum Peak Pulse Current ($t=8/20\mu s$)	I_{PP}	11	Amps
Lead Soldering Temperature	T_L	260 (10 sec.)	°C
Operating Temperature	T_J	-55 to +125	°C
Storage Temperature	T_{STG}	-55 to +150	°C

Symbol Definition

PARAMETER	SYMBOL
Maximum Reverse Peak Pulse Current	I_{PP}
Clamping Voltage @ I_{PP}	V_C
Working Peak Reverse Voltage	V_{RWM}
Maximum Reverse Leakage Current @ V_{RWM}	I_R
Breakdown Voltage @ I_t	V_{BR}
Test Current	I_t
Forward Current	I_F
Forward Voltage @ I_F	V_F
Peak Power Dissipation	P_{PK}
Max. Capacitance @ $V_R = 0V, f = 1MHz$	C

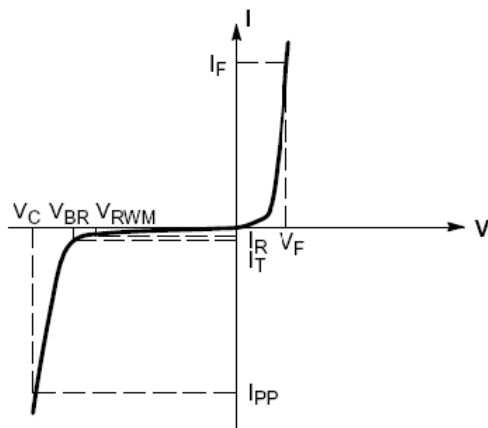

Uni-Directional TVS

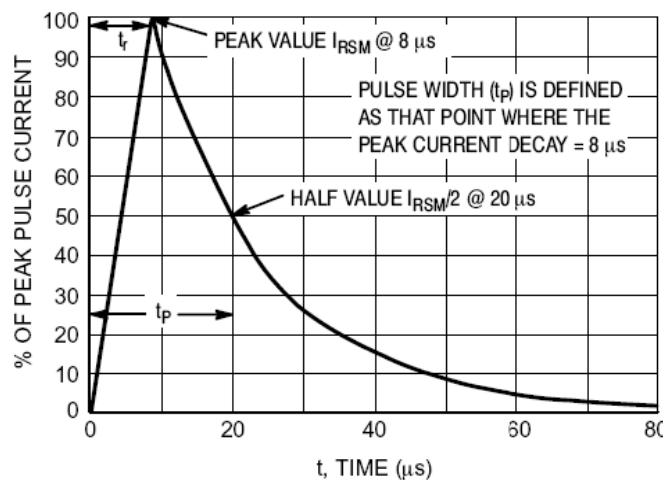

Electrical Characteristics

(T=25°C, Device for 5.0V Reverse Stand-off Voltage)

PARAMETER	SYMBOL	CONDITIONS	MIN	TYP	MAX	UNIT
Reverse Stand-Off Voltage	V_{RWM}				5	V
Reverse Breakdown Voltage	V_{BR}	$I_t = 1\text{mA}$	6	6.8	7.8	V
Reverse Leakage Current	I_R	$V_{RWM} = 5\text{V}, T=25^\circ\text{C}$			0.1	μA
Clamping Voltage	V_C	$I_{PP} = 5\text{A}, t_p = 8/20\mu\text{S}$			9.1	V
		$I_{PP} = 11\text{A}, t_p = 8/20\mu\text{S}$			13	
Forward Voltage	V_F	$I_F = 10\text{mA}$		0.8		V
Junction Capacitance	C_J	$V_R = 0\text{V}, f = 1\text{MHz}$		40	55	pF
Junction Capacitance	C_J	$V_R = 2.5\text{V}, f = 1\text{MHz}$		30	40	pF

Applications Information

Device Connection Options

UM5059 ESD protection diode is designed to protect one data, I/O, or power supply line. The device is unidirectional and may be used on lines where the signal polarity is above ground. The cathode dot should be placed towards the line that is to be protected.

Circuit Board Layout Recommendations for Suppression of ESD

Good circuit board layout is critical for the suppression of ESD induced transients. The following guidelines are recommended:

- 1) Place the TVS near the input terminals or connectors to restrict transient coupling.
- 2) Minimize the path length between the TVS and the protected line.
- 3) Minimize all conductive loops including power and ground loops.
- 4) The ESD transient return path to ground should be kept as short as possible.
- 5) Never run critical signals near board edges.
- 6) Use ground planes whenever possible. For multilayer printed-circuit boards, use ground vias.
- 7) Keep parallel signal paths to a minimum.
- 8) Avoid running protection conductors in parallel with unprotected conductor.
- 9) Minimize all printed-circuit board conductive loops including power and ground loops.
- 10) Avoid using shared transient return paths to a common ground point.

Package Information

UM5059 DFN2 1.0×0.6

Outline Drawing

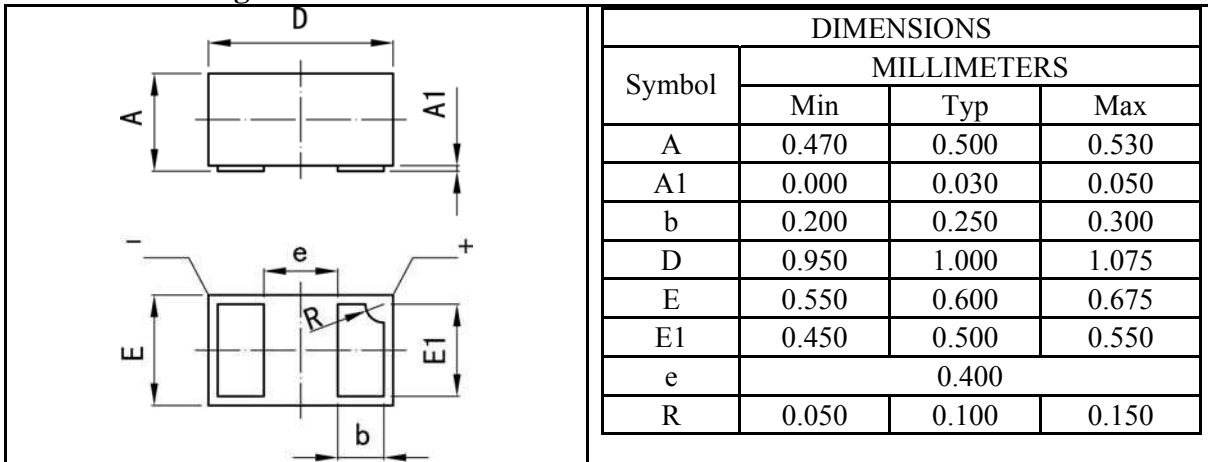

Land Pattern

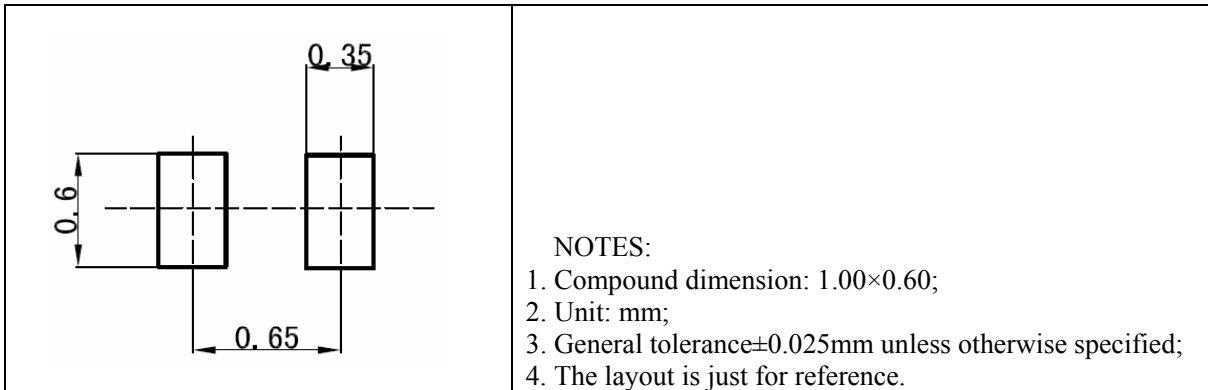

Tape and Reel Orientation

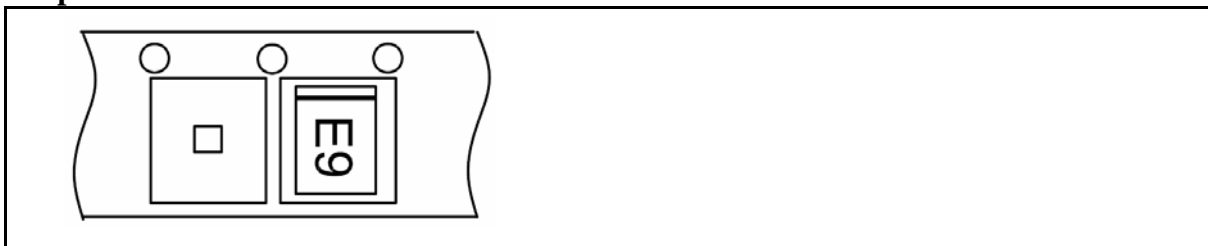

IMPORTANT NOTICE

The information in this document has been carefully reviewed and is believed to be accurate. Nonetheless, this document is subject to change without notice. Union assumes no responsibility for any inaccuracies that may be contained in this document, and makes no commitment to update or to keep current the contained information, or to notify a person or organization of any update. Union reserves the right to make changes, at any time, in order to improve reliability, function or design and to attempt to supply the best product possible.



Union Semiconductor, Inc

Add: 2F, No. 3, Lane 647 Songtao Road, Shanghai 201203

Tel: 021-51093966

Fax: 021-51026018

Website: www.union-ic.com