

60V (D-S) Small Signal MOSFET

UM2362S SOT23-3

UM2362P SOT323

General Description

The UM2362 is a low threshold N-channel MOSFET, which has low on-resistance, high reliability and stability, as well as fast switch capability and high saturation current. This benefit provides the designer with an extremely efficient device for use in battery and load management applications. The devices use a space-saving, small-outline SOT23-3 or SOT323 package.

Applications

- Battery Packs
- Battery-powered Portable Equipment
- Cellular and Cordless Telephones

Features

- Drain-Source Voltage(max): 60V
- Low On-Resistance(typ):
1.2Ω@V_{GS}=10V
1.7Ω@V_{GS}=5V
- Continuous Drain Current(max):
115mA@25°C

Pin Configurations

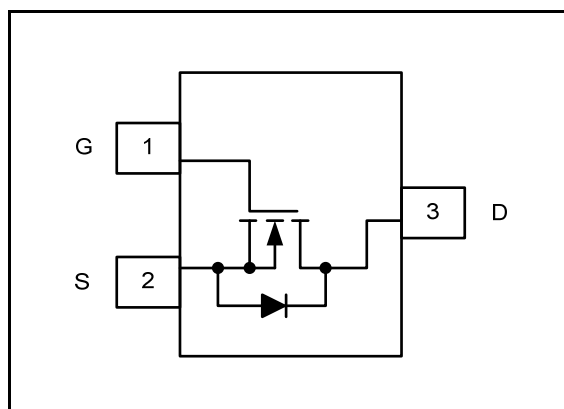

Top View

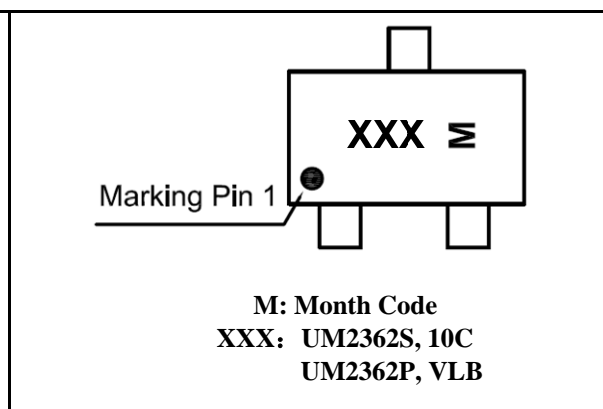

Ordering Information

Part Number	Packaging Type	Marking Code	Shipping Qty
UM2362S	SOT23-3	10C	3000pcs/7 Inch Tape & Reel
UM2362P	SOT323	VLB	3000pcs/7 Inch Tape & Reel

Absolute Maximum Ratings (T_{amb}=25°C)

Symbol	Parameter	Value	Units
V _{DSS}	Drain-Source voltage	60	V
V _{GS}	Gate-Source voltage	±20	V
I _D	Continuous Drain Current	115	mA
P _D	Power Dissipation	200	mW
T _J	Junction Temperature	+150	°C
T _{stg}	Storage Temperature	-55 to +150	°C

Electrical Characteristics (T_{amb}=25°C, Unless otherwise noted)

Symbol	Parameter	Test Condition	Min	Typ	Max	Unit
Off Characteristics						
BV _{DSS}	Drain to Source Breakdown Voltage	V _{GS} =0V, I _D =10μA	60			V
		V _{GS} =0V, I _D =3mA	60			
I _{DSS}	Zero Gate Voltage Drain Current	V _{DS} =60V, V _{GS} =0V			1	μA
I _{GSS}	Gate-to-Source Leakage Current	V _{GS} =±20V, V _{DS} =0V			±100	nA
On Characteristics						
R _{DS(ON)} *	Static Drain-to-Source On-Resistance	V _{GS} =10V, I _D =500mA		1.2	7.5	Ω
		V _{GS} =5V, I _D =50mA		1.7	7.5	
V _{GS(TH)} *	Gate Threshold Voltage	V _{DS} =V _{GS} , I _D =250μA	1		2.5	V
I _{D(ON)} *	Drain-to-Source On Current	V _{GS} =10V, V _{DS} =7V	500			mA
V _{DS(ON)} *	Drain-to-Source On Voltage	V _{GS} =10V, I _D =500mA			3.75	V
		V _{GS} =5V, I _D =50mA			0.375	
g _{fs} *	Forward Transconductance	V _{DS} =10V, I _D =200mA	80			mS
Drain-Source Diode Characteristics and Maximum Ratings						
V _{SD}	Forward Diode Voltage	V _{GS} =0V, I _S =115mA			1.2	V

*Pulse test: Pulse Width≤300μs, Duty Cycle≤2%

Package Information

UM2362S SOT23-3

Outline Drawing

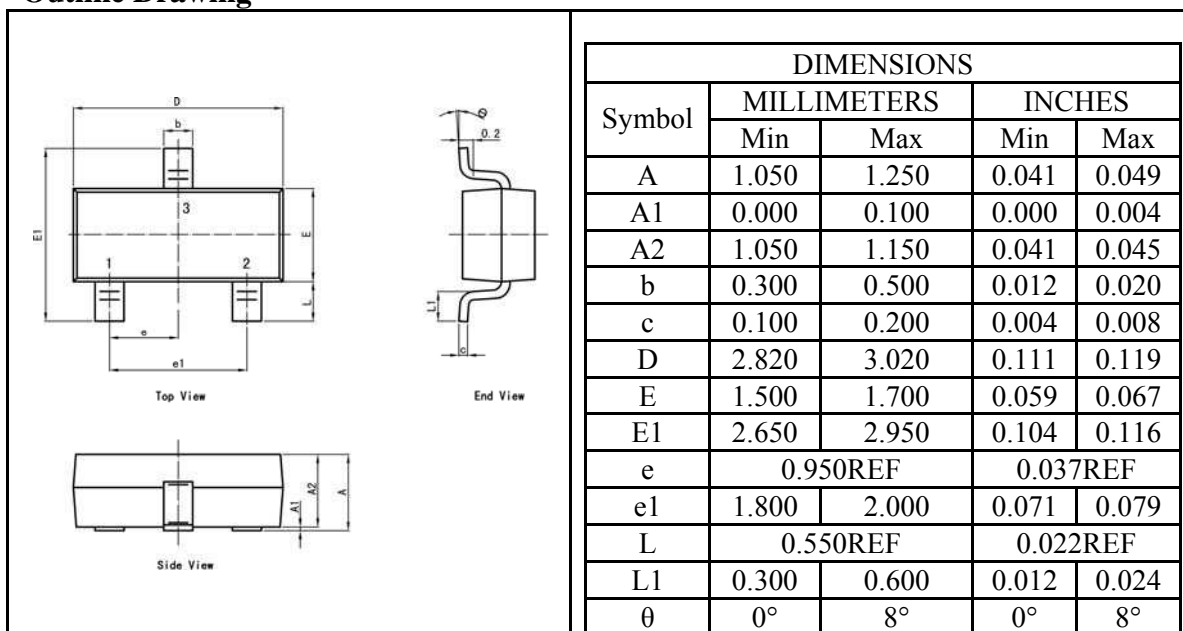

Land Pattern

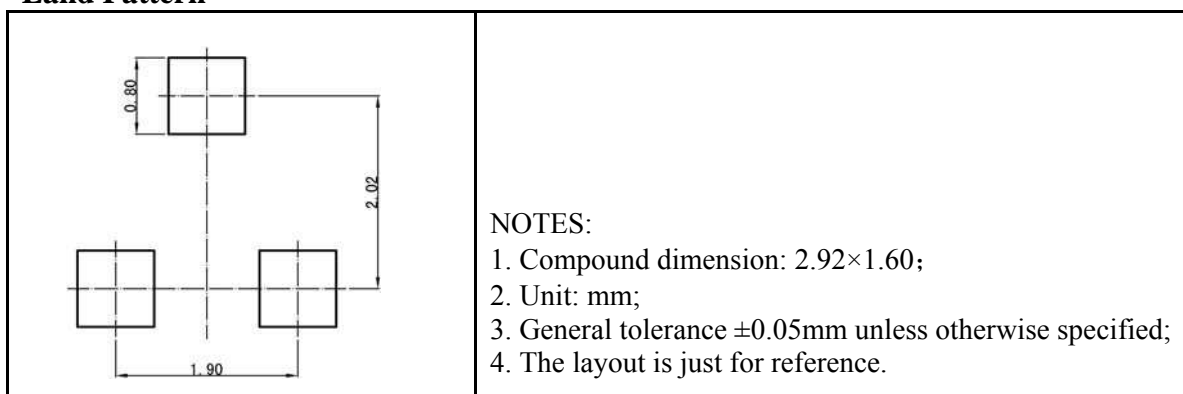

Tape and Reel Orientation

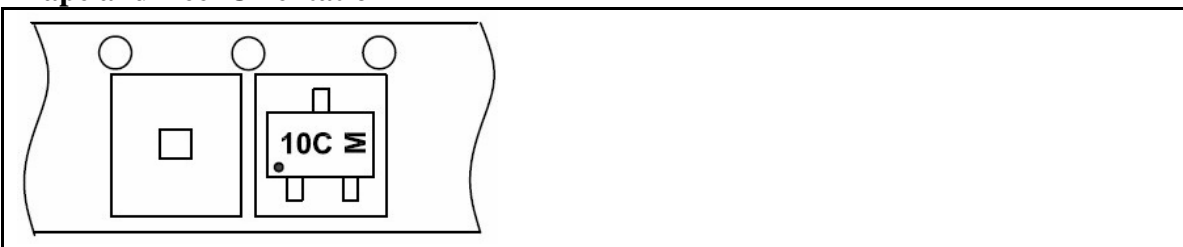

Package Information

UM2362P SOT323

Outline Drawing

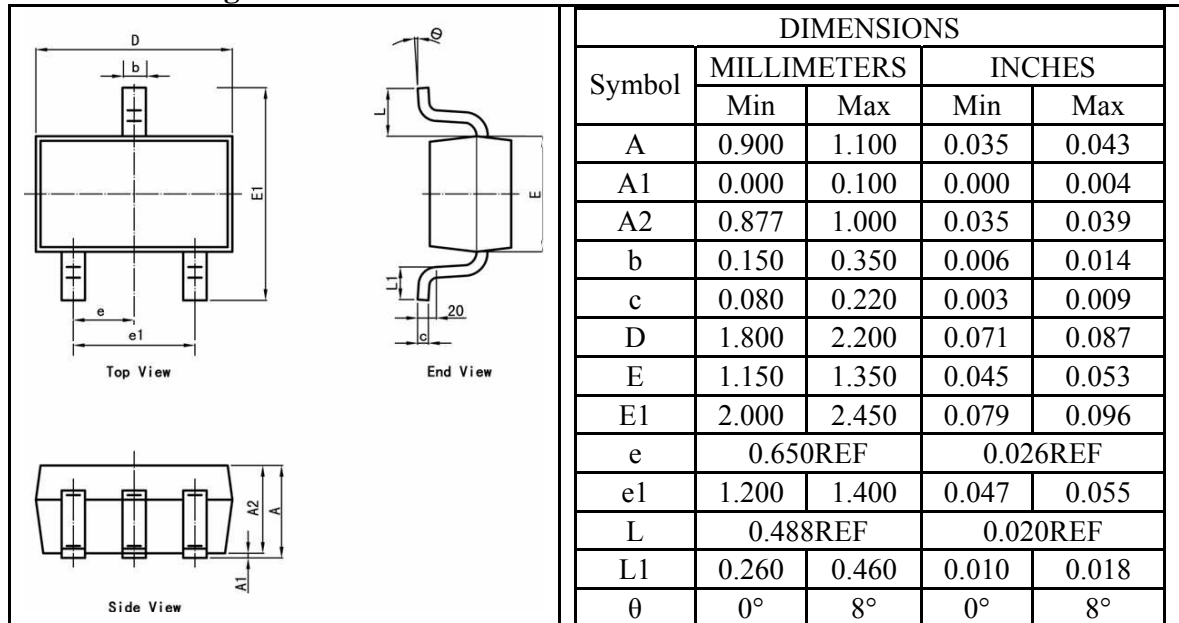

Land Pattern

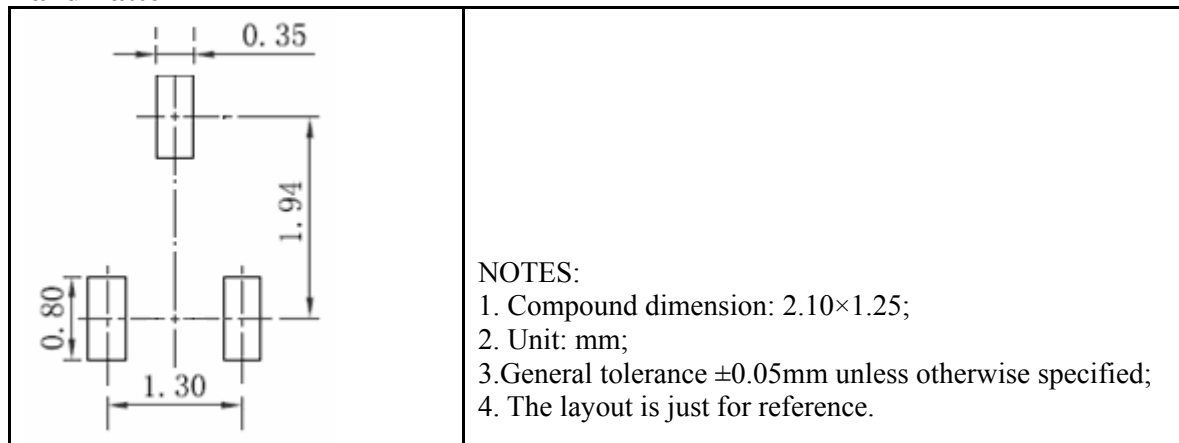

Tape and Reel Orientation

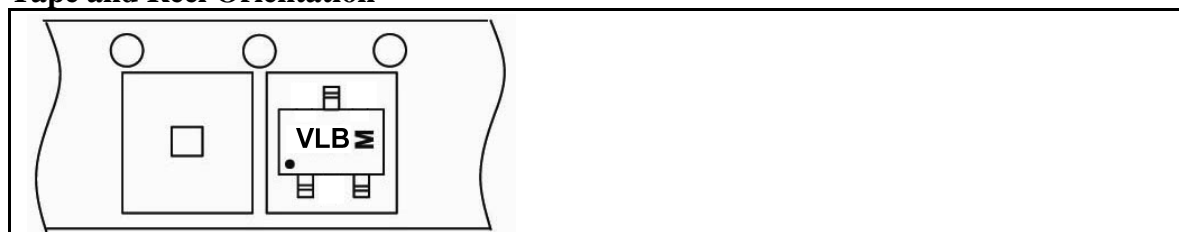

IMPORTANT NOTICE

The information in this document has been carefully reviewed and is believed to be accurate. Nonetheless, this document is subject to change without notice. Union assumes no responsibility for any inaccuracies that may be contained in this document, and makes no commitment to update or to keep current the contained information, or to notify a person or organization of any update. Union reserves the right to make changes, at any time, in order to improve reliability, function or design and to attempt to supply the best product possible.



Union Semiconductor, Inc

Add: 2F, No. 3, Lane 647 Songtao Road, Shanghai 201203

Tel: 021-51093966

Fax: 021-51026018

Website: www.union-ic.com