

## 5 Line ESD Protection Diode Array

### UESD6V85CT36 SC70-6 / SC88 / SOT363

#### General Description

The UESD6V85CT36 of TVS array is designed to protect sensitive electronics from damage or latch-up due to ESD, for use in applications where board space is at a premium. It is unidirectional device and may be used on lines where the signal polarities are above ground, each device will protect up to five lines.

TVS diodes are solid-state devices feature large cross-sectional area junctions for conducting high transient currents, specifically for transient suppression. It offers desirable characteristics for board level protection including fast response time, low clamping voltage, and no device degradation.

The UESD6V85CT36 may be used to meet the ESD immunity requirements of IEC 61000-4-2, Level 4. The small package makes them ideal for use in portable electronics such as cell phones, PDAs, notebook computers, and digital cameras.

#### Applications

Cellular Handsets & Accessories  
 Cordless Phones  
 Personal Digital Assistants (PDAs)  
 Notebooks & Handhelds  
 Portable Instrumentation  
 Digital Cameras  
 Peripherals  
 MP3 Players

#### Features

Transient protection for data lines to  
 IEC 61000-4-2 (ESD) 15kV (air), 8kV (contact)  
 Protects five I/O lines  
 Ultra-small SC70-6/SC88/SOT363 package  
 Working voltage: 5V  
 Low leakage current  
 Low operating and clamping voltages  
 Solid-state silicon-avalanche technology

#### Pin Configurations

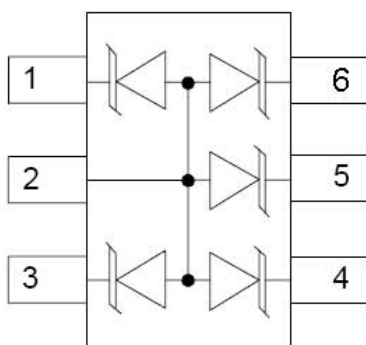

#### Top View

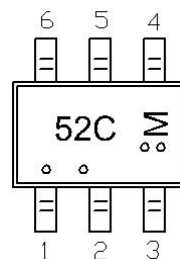

“.”:Option

M: Monthly Code  
**UESD6V85CT36**  
**SC70-6 / SC88 / SOT363**

## Ordering Information

Part Number	Working Voltage	Packaging Type	Channel	Marking Code	Shipping Qty
UESD6V85CT36	5.0V	SC70-6 / SC88 / SOT363	5	52C	3000/7 Inch Reel

## Absolute Maximum Ratings

RATING	SYMBOL	VALUE	UNITS
Peak Pulse Power ( $t_p = 8/20 \mu s$ ) @ $T_A \leq 25^\circ C$	$P_{PK}$	140	Watts
Thermal Resistance, Junction to Ambient	$R_{\theta JA}$	325	$^\circ C/W$
Lead Soldering Temperature	$T_L$	260(10 sec.)	$^\circ C$
Operating Temperature	$T_J$	-55 to +125	$^\circ C$
Storage Temperature	$T_{STG}$	-55 to +125	$^\circ C$
Maximum Junction Temperature	$T_{JMAX}$	150	$^\circ C$

## Electrical Characteristics

PARAMETER	SYMBOL	CONDITIONS	MIN	TYP	MAX	UNIT
Reverse Stand-Off Voltage	$V_{RWM}$				5	V
Reverse Breakdown Voltage	$V_{BR}$	$I_t = 1mA$	6	6.8	7.2	V
Reverse Leakage Current	$I_R$	$V_{RWM} = 5V, T=25^\circ C$			0.1	$\mu A$
Clamping Voltage	$V_C$	$I_{PP} = 5A, t_p = 8/20\mu S$			9.1	V
		$I_{PP} = 11A, t_p = 8/20\mu S$			13	
Junction Capacitance	$C_J$	Pin 1, 3, 4, 5, 6 to 2 $V_R = 0V, f = 1MHz$		40	50	pF
Junction Capacitance	$C_J$	Pin 1, 3, 4, 5, 6, to 2 $V_R = 2.5V, f = 1MHz$		30	40	pF

## Typical Operating Characteristics

### Non-Repetitive Peak Pulse Power vs. Pulse Time

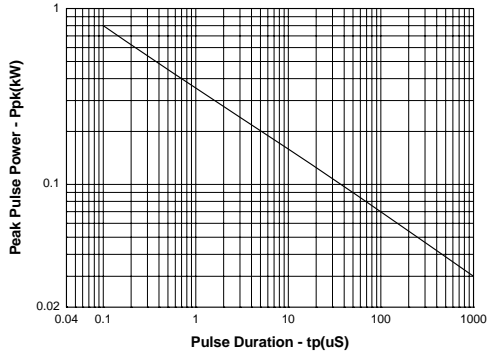

### Clamping Voltage vs. Peak Pulse Current

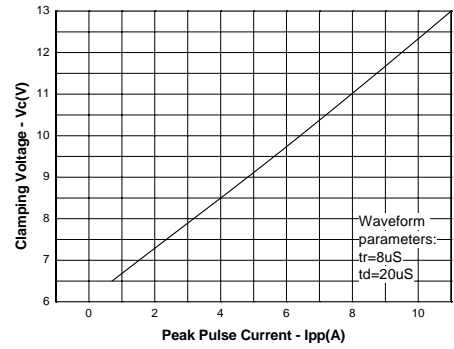

### Forward Voltage vs. Forward Current

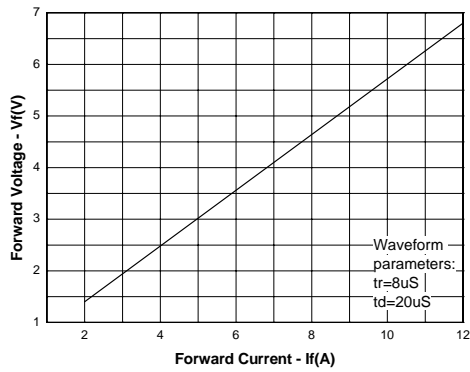

### Junction Capacitance vs. Reverse Voltage

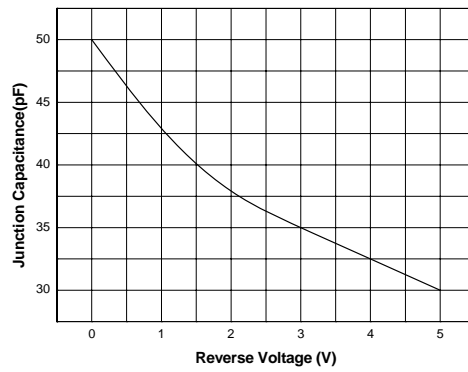

## Applications Information

UESD6V85CT36 ESD protection diode is designed to protect 5 data, I/O, or power supply line. The device is unidirectional and may be used on lines where the signal polarity is above ground. The cathode should be placed towards the line that is to be protected.

### Device Connection for Protection of Quad Data Lines

The UESD6V85CT36 TVS diode array is designed to protect up to five unidirectional data lines. The device as follows:

Unidirectional protection of five I/O lines is achieved by connecting pins 1, 3, 4, 5, and 6 to the data lines. Pin 2 is connected to ground. The ground connection should be made directly to the ground plane for best results. The path length is kept as short as possible to reduce the effects of parasitic inductance in the board traces.

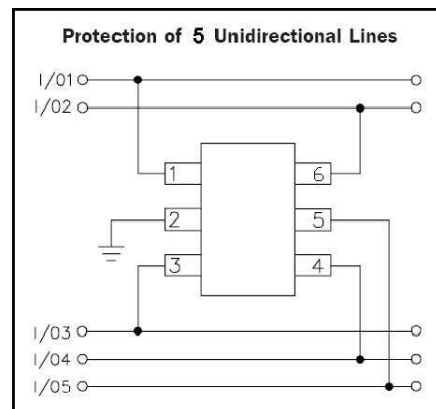
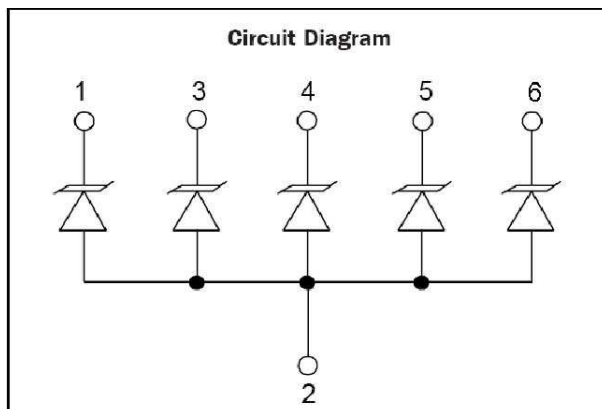

### Circuit Board Layout Recommendations for Suppression of ESD

Good circuit board layout is critical for the suppression of ESD induced transients. The following guidelines are recommended:

- Place the TVS near the input terminals or connectors to restrict transient coupling.

- Minimize the path length between the TVS and the protected line.

- Minimize all conductive loops including power and ground loops.

- The ESD transient return path to ground should be kept as short as possible.

- Never run critical signals near board edges.

- Use ground planes whenever possible. For multilayer printed-circuit boards, use ground vias.

- Keep parallel signal paths to a minimum.

- Avoid running protection conductors in parallel with unprotected conductor.

- Minimize all printed-circuit board conductive loops including power and ground loops.

- Avoid using shared transient return paths to a common ground point.

## Package Information

### UESD6V85CT36 SC70-6 / SC88 / SOT363

#### Outline Drawing

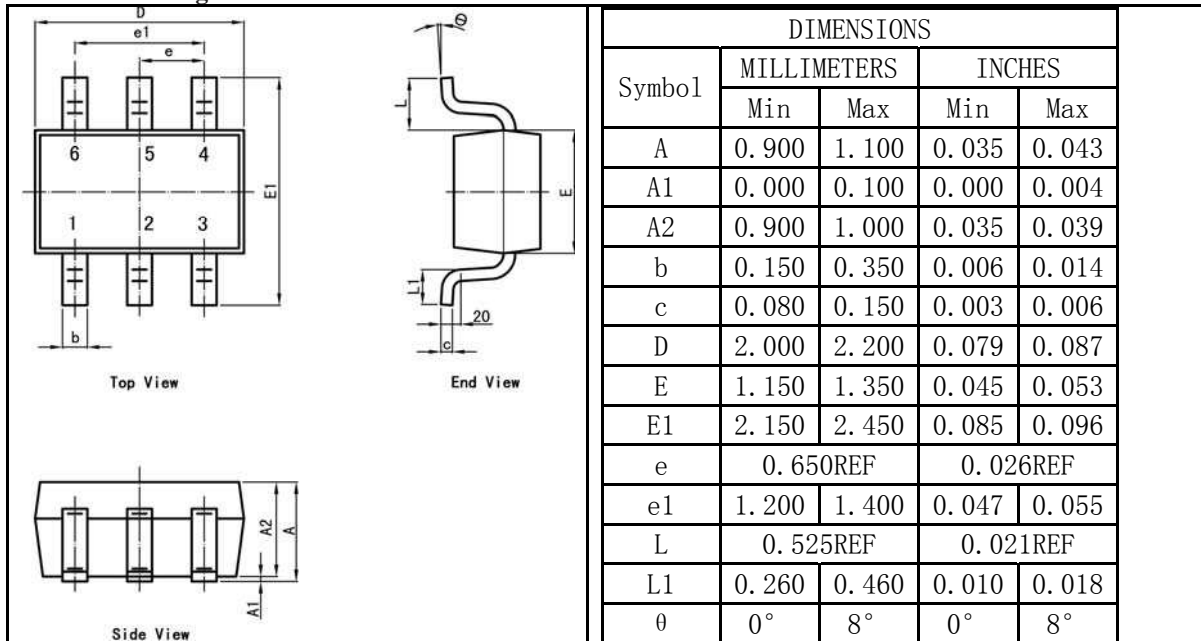

#### Land Pattern

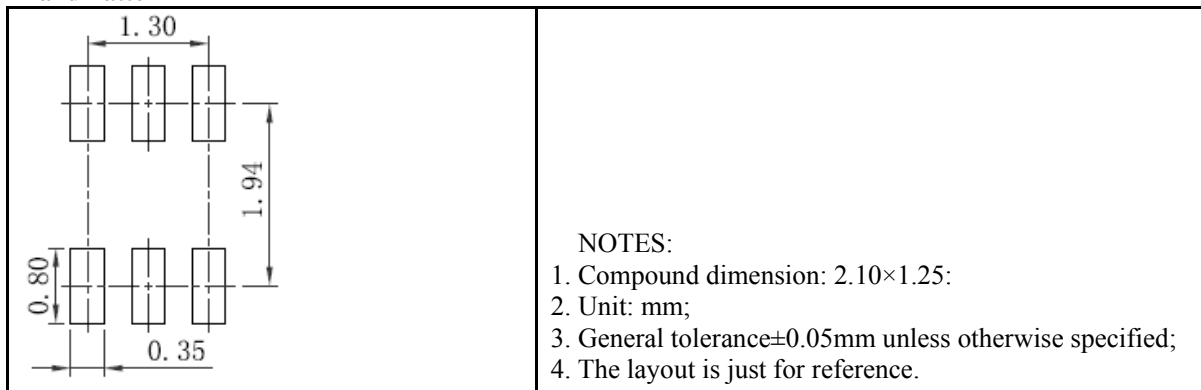

#### Tape and Reel Orientation

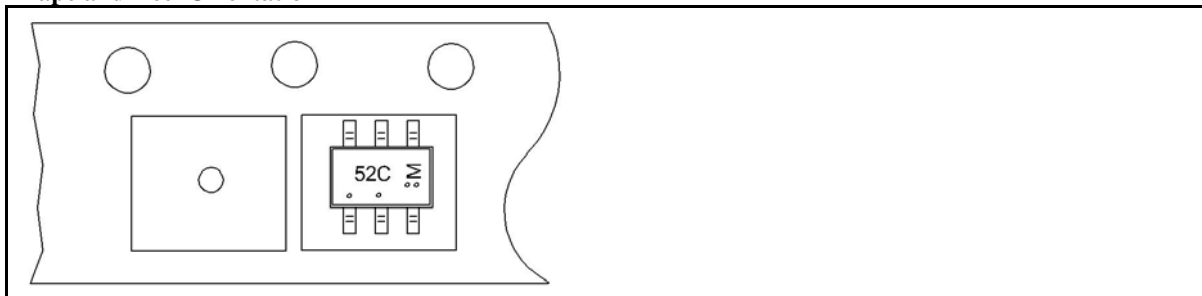

## IMPORTANT NOTICE

The information in this document has been carefully reviewed and is believed to be accurate. Nonetheless, this document is subject to change without notice. Union assumes no responsibility for any inaccuracies that may be contained in this document, and makes no commitment to update or to keep current the contained information, or to notify a person or organization of any update. Union reserves the right to make changes, at any time, in order to improve reliability, function or design and to attempt to supply the best product possible.

Union Semiconductor, Inc  
Add: 7F, No. 5, Bibo Road, Shanghai 201203  
Tel: 021-51097928  
Fax: 021-51026018  
Website: [www.union-ic.com](http://www.union-ic.com)